

CGS74LCT2524

1 to 4 Minimum Skew (300 ps) 3V Clock Driver

General Description

This minimum skew clock driver is a 3V option of the current CGS74CT2524 Minimum Skew Clock Driver and is designed for Clock Generation and Support (CGS) applications operating at low voltage, high frequencies. This device guarantees minimum output skew across the outputs of a given device.

Skew parameters are also provided as a means to measure duty cycle requirements as those found in high speed clocking systems. This minimum skew clock driver with one input driving four outputs, is specifically designed for signal generation and clock distribution applications.

Features

- Ideal for low power/low noise high speed applications
- Guaranteed:
 - 300 ps pin-to-pin skew (t_{OSHL} and t_{OSLH})
- Implemented on National's FACT™ family process
- 1 input to 4 outputs low skew clock distribution
- Symmetric output current drive: 12 mA I_{OH}/I_{OL}
- Industrial temperature of -40°C to $+85^{\circ}\text{C}$
- 8-pin SOIC package
- Low dynamic power consumption above 20 MHz
- Guaranteed 2 kV ESD protection

Logic Symbol

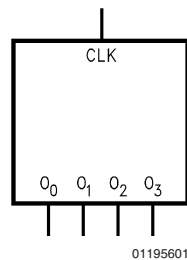

The output pins act as a single entity and will follow the state of the CLK when the clock distribution chip is selected.

Pin Description

Pin Names	Description
CLK	Clock Input
O_0-O_3	Outputs

Truth Table

Inputs	Outputs
CLK	O_0-O_3
L	L
H	H

L = Low Logic Level
H = High Logic Level

Connection Diagrams

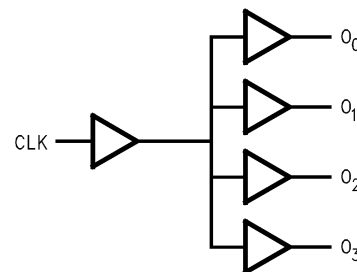
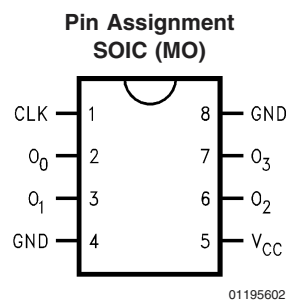

See NS Package Number M08A

Absolute Maximum Ratings (Note 1)

If Military/Aerospace specified devices are required, please contact the National Semiconductor Sales Office/Distributors for availability and specifications.

Supply Voltage (V_{CC})	-0.5V to 7.0V
DC Input Voltage Diode Current (I_{IK})	
$V = -0.5V$	-20 mA
$V = V_{CC} + 0.5V$	+20 mA
DC Input Voltage (V_I)	-0.5V to V_{CC}
	+0.5V
DC Output Diode Current (I_O)	
$V = -0.5V$	-20 mA
$V = V_{CC} + 0.5V$	+20 mA
DC Output Voltage (V_O)	-0.5V to V_{CC}
	+0.5V
DC Output Source or Sink Current (I_O)	±50 mA
DC V_{CC} or Ground Current per Output Pin (I_{CC} or I_{GND})	±50 mA
Storage Temperature (T_{STG})	-65°C to +150°C

Junction Temperature (θ_{JA})

Airflow	0	225	500 LFM
	M	167	132 117 °C/W

Recommended Operating Conditions

Supply Voltage (V_{CC})	3.0V to 3.6V
Input Voltage (V_{IN})	0V to V_{CC}
Output Voltage (V_O)	0V to V_{CC}
Operating Temperature (T_A)	
Industrial	-40°C to +85°C
Commercial	0°C to +70°C
Input Rise and Fall Times (0.8V to 2.0V)	9.6 ns max

Note 1: The Absolute Maximum Ratings are those values beyond which the safety of the device cannot be guaranteed. The device should not be operated at these limits. The parametric values defined in the DC and AC Electrical Characteristics tables are not guaranteed at the absolute maximum ratings. The Recommended Operating Conditions will define the conditions for actual device operation.

DC Electrical Characteristics

Over recommended operating conditions unless specified otherwise.

Symbol	Parameter	Conditions	V_{CC} (V)	CGS74LCT2524			Units
				$T_A = +25^\circ\text{C}$		$T_A = -40^\circ\text{C to } +85^\circ\text{C}$	
				Typ	Guaranteed Limits		
V_{IH}	Minimum High Level Input Voltage	$V_{OUT} = 0.1V$ or $V_{CC}-0.1V$	3.6	1.5	2.0	2.0	V
V_{IL}	Maximum Low Level Input Voltage	$V_{OUT} = 0.1V$ or $V_{CC}-0.1V$	3.6	1.5	0.8	0.8	V
V_{OH}	Minimum High Level Output Voltage	$V_{IN} = V_{IL}$ or V_{IH} , $I_{OUT} = -50 \mu\text{A}$	3.0		2.9	2.9	V
		$V_{IN} = V_{IL}$ or V_{IH} , $I_{OH} = -12 \text{ mA}$	3.0		2.5	2.4	V
V_{OL}	Minimum Low Level Output Voltage	$V_{IN} = V_{IL}$ or V_{IH} , $I_{OUT} = 50 \mu\text{A}$	3.0		0.1	0.1	V
		$V_{IN} = V_{IL}$ or V_{IH} , $I_{OL} = -12 \text{ mA}$	3.0		0.3	0.4	V
I_{IN}	Maximum Input Leakage Current	$V_{IN} = V_{CC}$, GND	3.6		±0.1	±1.0	μA
I_{CCT}	Maximum I_{CC} /Input	$V_{IN} = 3.0V$	3.6			100	μA
I_{OLD}	Minimum Dynamic Output Current	$V_{OLD} = 0.8V$ (max)	3.6			36	mA
I_{OHD}		$V_{OHD} = 2.0V$ (min)	3.6			-25	mA
I_{CC}	Maximum Quiescent Supply Current	$V_{IN} = V_{CC}$ or GND	3.6		2.5	10	μA

AC Electrical Characteristics

Over recommended operating conditions unless specified otherwise. All typical values are measured at $V_{CC} = 3.3V$, $T_A = 25^\circ C$

Symbol	Parameter	LCT2524			Units
		$V_{CC} = 3.0V \text{ to } 3.6V$ $T_A = -40^\circ C \text{ to } +85^\circ C$ $C_L = 50 \text{ pF}$ $R_L = 500\Omega$			
		Min	Typ	Max	
t_{PLH}	Low-to-High Propagation Delay CLK to O_n	6		15.0	ns
t_{PHL}	High-to-Low Propagation Delay CLK to O_n	6		15.0	ns

Extended AC Electrical Characteristics

Over recommended operating conditions unless specified otherwise. All typical values are measured at $V_{CC} = 3.3V$, $T_A = 25^\circ C$

Symbol	Parameter	LCT2524			Units
		$V_{CC} = 3.0V \text{ to } 3.6V$ $T_A = -40^\circ C \text{ to } +85^\circ C$ $C_L = 50 \text{ pF}$ $R_L = 500\Omega$			
		Min	Typ	Max	
f_{max}	Maximum Operating Frequency		75		MHz
t_{OSHL}	Maximum Skew Common Edge Output-to-Output Variation (Note 2)			300	ps
t_{OSLH}	Maximum Skew Common Edge Output-to-Output Variation (Note 2)			300	ps
t_{PS}	Maximum Skew Pin (Signal) Transition Variation (Note 3)			2.5	ns
t_{RISE} t_{FALL}	Rise Time/Fall Time (from 0.8V to 2.0V/2.0V to 0.8V)			2.5	ns
T_{HIGH}	Time High	4			ns
T_{LOW}	Time Low	4			ns

Note 2: Output-to-Output Skew is defined as the absolute value of the difference between the actual propagation delay for any outputs within the same packaged device. The specifications apply to any outputs switching in the same direction either HIGH-to-LOW (t_{OSHL}) or LOW-to-HIGH (t_{OSLH}) or in opposite directions both HL and LH (t_{OST}). Limits are characterized and guaranteed by design @ 66 MHz.

Note 3: Pin transition skew is the absolute difference between HIGH-to-LOW and LOW-to-HIGH propagation delay, measured at a given output pin.

Note 4: Refer to Minimum Skew Parameters Measurement Information Chart for definitions of each skew specification.

Note 5: Load capacitance includes the test jig.

Timing Diagrams

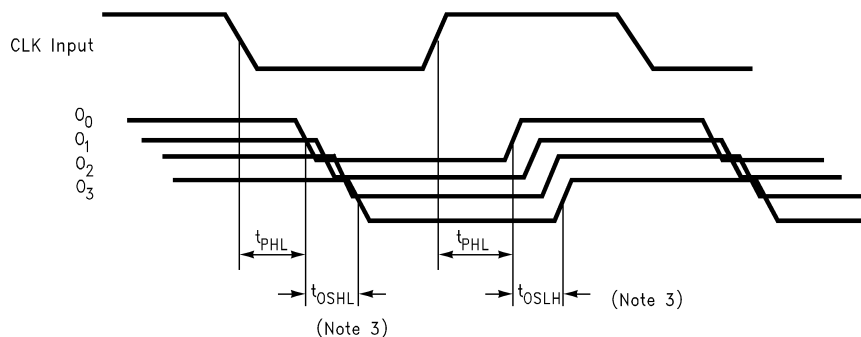

01195605

Timing Diagrams (Continued)

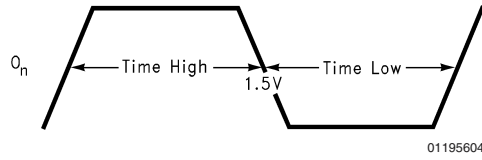
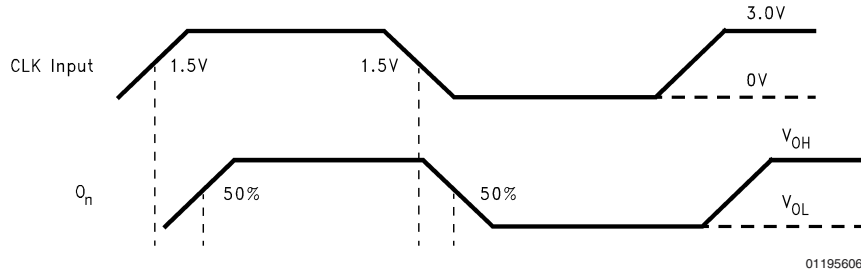

Test Circuit

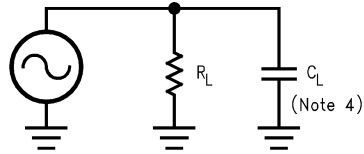

R_L is 500Ω
 C_L is 50 pF for all propagation delays and skew measurements.

Ordering Information (Contact NSC Marketing for specific date of availability)

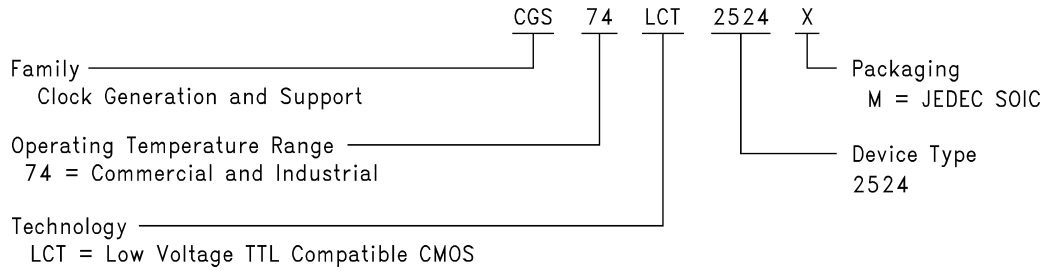

01195608

Physical Dimensions inches (millimeters)

unless otherwise noted

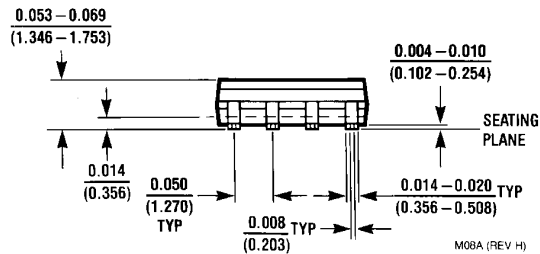
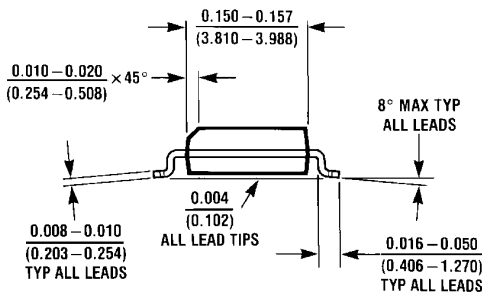
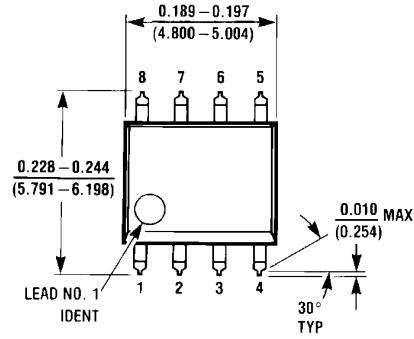

8-Lead (0.150" Wide) Molded Small Outline Package, JEDEC
Order Number CGS74LCT2524M
NS Package Number M08A

LIFE SUPPORT POLICY

NATIONAL'S PRODUCTS ARE NOT AUTHORIZED FOR USE AS CRITICAL COMPONENTS IN LIFE SUPPORT DEVICES OR SYSTEMS WITHOUT THE EXPRESS WRITTEN APPROVAL OF THE PRESIDENT AND GENERAL COUNSEL OF NATIONAL SEMICONDUCTOR CORPORATION. As used herein:

1. Life support devices or systems are devices or systems which, (a) are intended for surgical implant into the body, or (b) support or sustain life, and whose failure to perform when properly used in accordance with instructions for use provided in the labeling, can be reasonably expected to result in a significant injury to the user.
2. A critical component is any component of a life support device or system whose failure to perform can be reasonably expected to cause the failure of the life support device or system, or to affect its safety or effectiveness.

BANNED SUBSTANCE COMPLIANCE

National Semiconductor certifies that the products and packing materials meet the provisions of the Customer Products Stewardship Specification (CSP-9-111C2) and the Banned Substances and Materials of Interest Specification (CSP-9-111S2) and contain no "Banned Substances" as defined in CSP-9-111S2.



National Semiconductor
Americas Customer
Support Center
 Email: new.feedback@nsc.com
 Tel: 1-800-272-9959

www.national.com

National Semiconductor
Europe Customer Support Center
 Fax: +49 (0) 180-530 85 86
 Email: europe.support@nsc.com
 Deutsch Tel: +49 (0) 69 9508 6208
 English Tel: +44 (0) 870 24 0 2171
 Français Tel: +33 (0) 1 41 91 8790

National Semiconductor
Asia Pacific Customer
Support Center
 Email: ap.support@nsc.com

National Semiconductor
Japan Customer Support Center
 Fax: 81-3-5639-7507
 Email: jpn.feedback@nsc.com
 Tel: 81-3-5639-7560

National Semiconductor was acquired by Texas Instruments.

http://www.ti.com/corp/docs/investor_relations/pr_09_23_2011_national_semiconductor.html

This file is the datasheet for the following electronic components:

CGS74LCT2524M - <http://www.ti.com/product/cgs74lct2524m?HQS=TI-null-null-dscatalog-df-pf-null-ww>

CGS74LCT2524MX - <http://www.ti.com/product/cgs74lct2524mx?HQS=TI-null-null-dscatalog-df-pf-null-ww>



LittleDiode supplies new, hard to find or obsolete electronic components and semiconductors all over the world.

With over two million different components listed you are sure to find the part you need.

Feel free to visit us today at our online store:

LittleDiode.com

Looking forward to providing you with the best possible service.