

CLC5523

Low Power, Variable Gain Amplifier

General Description

The CLC5523 is a low power, wideband, DC-coupled, voltage controlled gain amplifier. It provides a voltage controlled gain block coupled with a current feedback output amplifier. High impedance inputs and minimum dependence of bandwidth on gain make the CLC5523 easy to use in a wide range of applications. This amplifier is suitable as a continuous gain control element in a variety of electronic systems which benefit from a wide bandwidth of 250MHz and high slew rate of 1800V/ μ s, with only 135mW of power dissipation.

Input impedances in the megaohm range on both the signal and gain control inputs simplify driving the CLC5523 in any application. The CLC5523 can be configured to use pin 3 as a low impedance input making it an ideal interface for current inputs. By using the CLC5523's inverting configuration in which R_g is driven directly, inputs which exceed the device's input voltage range may be used.

The gain control input (V_g) with a 0 to 2V input range, and a linear-in-dB gain control, simplifies the implementation of AGC circuits. The gain control circuit can adjust the gain as fast as 4dB/ns. Maximum gains from 2 to 100 are accurately and simply set by two external resistors while attenuation of up to 80dB from this gain can be achieved.

The extremely high slew rate of 1800V/ μ s and wide bandwidth provides high speed rise and fall times of 2.0ns, with settling time for a 2 volt step of only 22ns to 0.2%. In time domain applications where linear phase is important with gain adjust, the internal current mode circuitry maintains low deviation of delay over a wide gain adjust range.

Features

- Low power: 135mW
- 250MHz, -3dB bandwidth
- Slew rate: 1800V/ μ s
- Gain flatness: 0.2d @ 75MHz
- Rise & fall times: 2.0ns
- Low input voltage noise: $4nV/\sqrt{Hz}$

Applications

- Automatic gain control
- Voltage controlled filters
- Automatic signal leveling for A/D
- Amplitude modulation
- Variable gain transimpedance

Frequency Response with changes in V_g

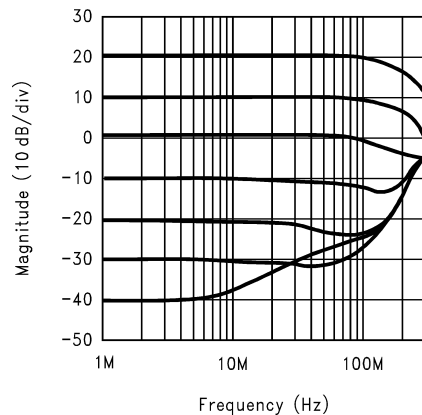

DS012798-1

Connection Diagram

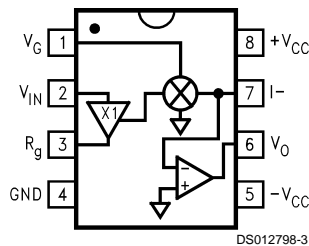

Pinout
DIP & SOIC

Typical Application

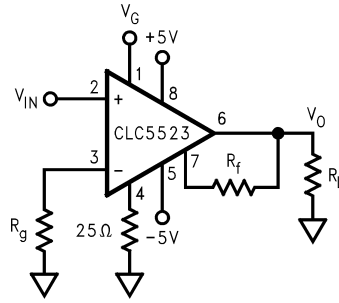

DS012798-2

Variable Gain Amplifier Circuit

Ordering Information

Package	Temperature Range Industrial	Part Number	Package Marking	NSC Drawing
8-pin plastic DIP	-40°C to +85°C	CLC5523IN	CLC5523IN	N08E
8-pin plastic SOIC	-40°C to +85°C	CLC5523IM	CLC5523IM	M08A

Absolute Maximum Ratings (Note 1)

If Military/Aerospace specified devices are required, please contact the National Semiconductor Sales Office/Distributors for availability and specifications.

Supply Voltage	±7V
Output Current	±96mA
Maximum Junction Temperature	+150°C
Storage Temperature Range	-65°C to +150°C

Lead Solder Duration (+300°C)

10 sec

Operating Ratings

	Thermal Resistance		
Package	(θ_{JC})	(θ_{JA})	
MDIP	65°C/W	115°C/W	
SOIC	55°C/W	135°C/W	

Electrical Characteristics

$V_{CC} = \pm 5V$, $R_f = 1k$, $R_g = 100\Omega$, $R_L = 100\Omega$, $V_g = 2V$; unless specified.

Symbol	Parameter	Conditions	Typ	Min/Max (Note 2)		Units
	Ambient Temperature	CLC5523I	+25°C	25°C	-40°C to 85°C	
Frequency Domain Response						
	-3dB Bandwidth	$V_O < 0.5V_{PP}$	250	150	125	MHz
	-3dB Bandwidth	$V_O < 4.0V_{PP}$ (AJE only)	100	45	35	MHz
	Peaking	DC to 200MHz ($V_O < 0.5V_{PP}$)	0	0.8	2.0	dB
	Rolloff	DC to 75MHz ($V_O < 0.5V_{PP}$)	0.2	1.0	1.2	dB
	Linear Phase Deviation	DC to 75MHz ($V_O < 0.5V_{PP}$)	0.6	1.5	3.0	deg
	Gain Control Bandwidth	$V_{IN} = 0.2V_{DC}$, $V_g = 1V_{DC}$	95	70	60	MHz
TIME DOMAIN RESPONSE						
	Rise and Fall Time	0.5V Step	2.0	2.8	3.0	ns
	Overshoot	0.5V Step	6.0	15	20	%
	Settling Time to ±0.2%	2V Step	22	30	60	ns
	Non-Inverting Slew Rate	4V Step	700	450	400	V/μs
	Inverting Slew Rate	4V Step	1800	1000	700	V/μs
	Gain Control Response Rate (Note 3)		4			dB/nS
DISTORTION AND NOISE RESPONSE						
	2nd Harmonic Distortion	1V _{PP} , 5MHz	-65	-	-	dBc
	3rd Harmonic Distortion	1V _{PP} , 5MHz	-80	-	-	dBc
	2nd Harmonic Distortion	1V _{PP} , 10MHz	-57	-52	-40	dBc
	3rd Harmonic Distortion	1V _{PP} , 10MHz	-75	-58	-54	dBc
	Input Referred Total Noise	$V_g = 2V$	5	6	7	nV/√Hz
	Input Referred Voltage Noise		4	5.5	5.5	nV/√Hz
	R _g Referred Current Noise		36	50	60	pA/√Hz
Static, DC Performance						
	Output Offset Voltage (Note 4)		50	120	150	mV
	V _{IN} Signal Input					
	Input Voltage Range	R _g Open	<±3.8	<±3.6	<±3.3	V
	Input Bias Current (Note 4)		3.0	8.0	16	μA
	Input Resistance		3.0	1.0	0.8	MΩ
	Input Capacitance		1.0	1.5	1.7	pF
	I _{Rgmax}	0° to 70°C	7.0	5.0	4.0	mA
	I _{Rgmax}	-40° to 85°C	7.0	5.0	2.5	mA
	Signal Ch. Non-Linearity SGNL	$V_O = 2V_{PP}$	0.04	0.1	0.2	%

Electrical Characteristics (Continued)

$V_{CC} = \pm 5V$, $R_f = 1k$, $R_g = 100\Omega$, $R_L = 100\Omega$, $V_g = 2V$; unless specified.

Symbol	Parameter	Conditions	Typ	Min/Max (Note 2)		Units
Static, DC Performance						
	Gain Accuracy (Note 4)		0.3	0.5	0.9	dB
	V_g Gain Input					
	Input Bias Current		0.5	2.0	4.0	μA
	Input Resistance		10	2.0	2.0	$M\Omega$
	Input Capacitance		1.0	1.5	1.5	pF
	Ground Pin Current		40	55	65	μA
	Power Supply Rejection Ratio (Note 4)	Input-Referred	57	50	46	dB
	Supply Current (Note 4)	$R_L = \infty$	13.5	15	16	mA
	Output Voltage Range	No Load	± 3.4	± 3.0	± 2.3	V
	Output Voltage Range	$R_L = 100\Omega$	± 3.0	± 2.5	± 2.3	V
	Output Impedance		0.1	0.15	0.15	Ω
	Output Current		80	65	50	mA
	Transistor Count		146			

Note 1: "Absolute Maximum Ratings" are those values beyond which the safety of the device cannot be guaranteed. They are not meant to imply that the devices should be operated at these limits. The table of "Electrical Characteristics" specifies conditions of device operation.

Note 2: Min/max ratings are based on product characterization and simulation. Individual parameters are tested as noted. Outgoing quality levels are determined from tested parameters.

Note 3: See plot "Gain Control Settling Time."

Note 4: AJ-level: spec. is 100% tested at +25°C.

Typical Performance Characteristics $V_g = +2V$, $R_f = 1k\Omega$, $R_g = 100\Omega$, $R_L = 100\Omega$, $V_O = 0.5V_{PP}$; unless specified.

Frequency Response, ($A_{vmax} = 10$)

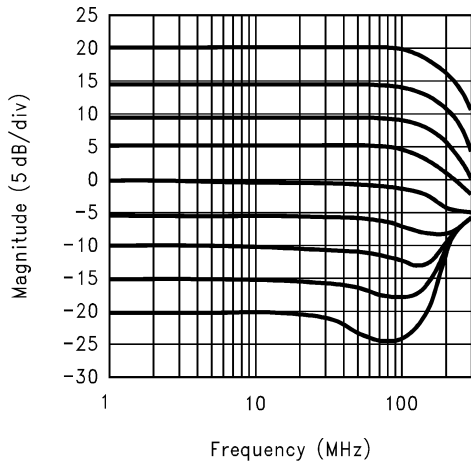

Frequency Response, ($A_{vmax} = 2$)

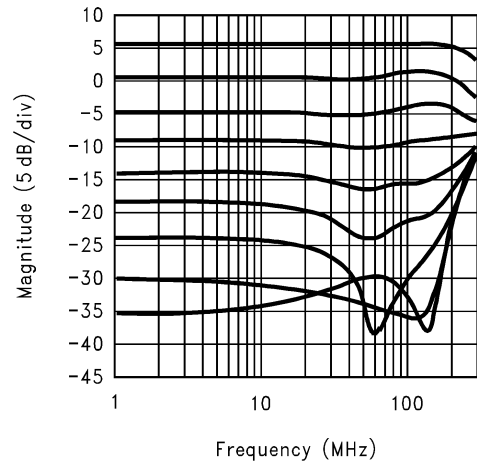

Typical Performance Characteristics $V_g = +2V$, $R_f = 1k\Omega$, $R_g = 100\Omega$, $R_L = 100\Omega$, $V_O = 0.5V_{PP}$; unless specified. (Continued)

Frequency Response, ($A_{v_{max}} = 100$)

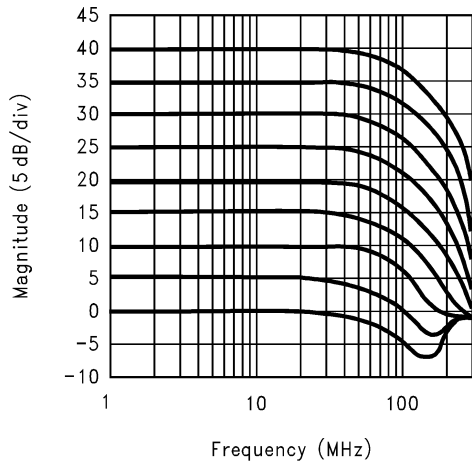

DS012798-6

Frequency Response vs. R_L

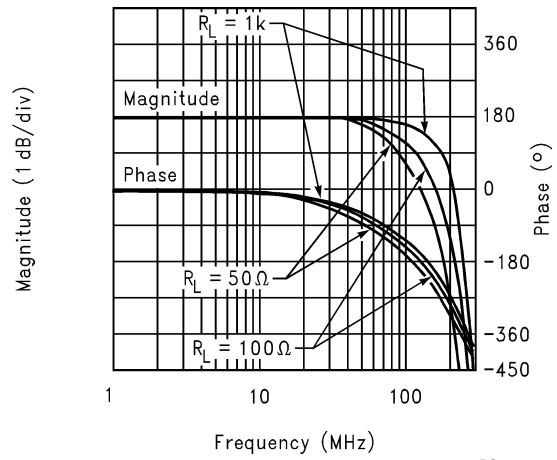

DS012798-7

Frequency Response vs. R_g

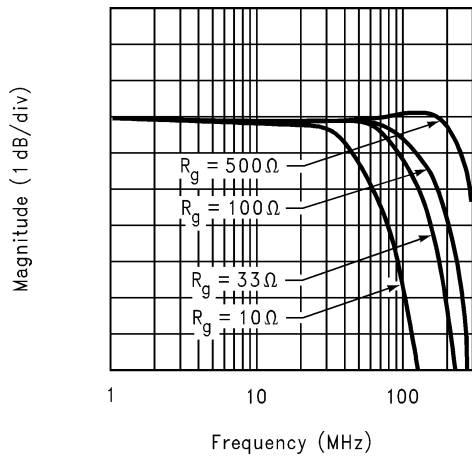

DS012798-8

Frequency Response vs. R_f

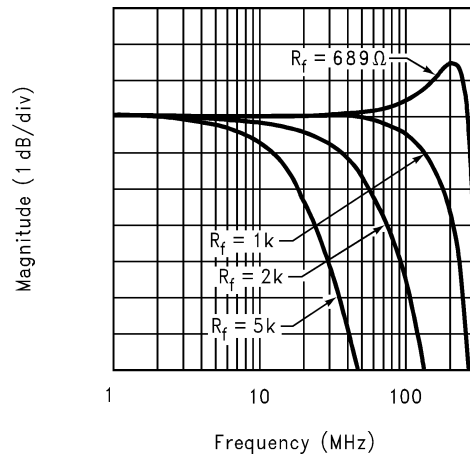

DS012798-9

Typical Performance Characteristics $V_g = +2V$, $R_f = 1k\Omega$, $R_g = 100\Omega$, $R_L = 100\Omega$, $V_O = 0.5V_{pp}$; unless specified. (Continued)

PSRR & R_{OUT}

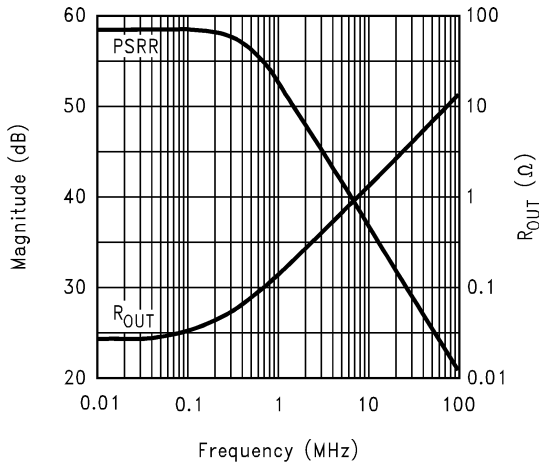

DS012798-10

Feed-Through Isolation ($V_g = 0, 2$)

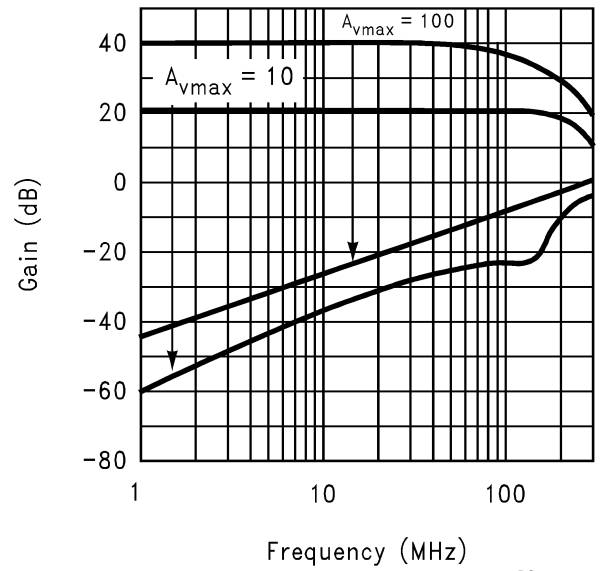

DS012798-11

Gain Flatness & Linear Phase Deviation

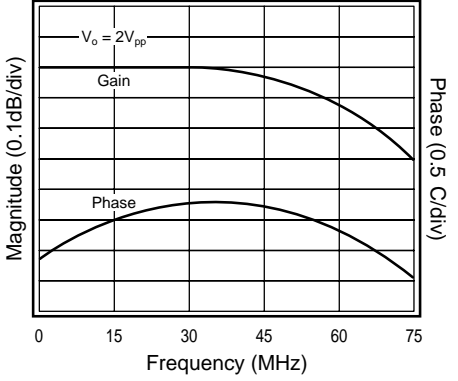

DS012798-12

Large Signal Frequency Response

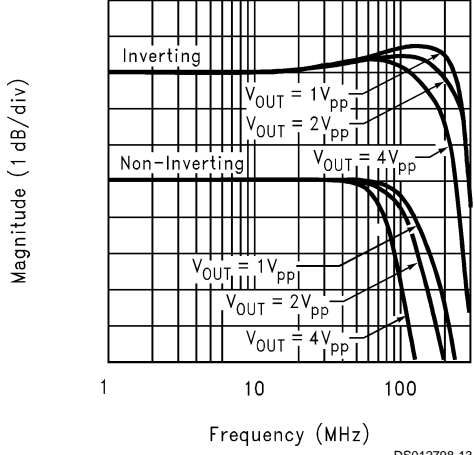

DS012798-13

Typical Performance Characteristics $V_g = +2V$, $R_f = 1k\Omega$, $R_g = 100\Omega$, $R_L = 100\Omega$, $V_O = 0.5V_{PP}$; unless specified. (Continued)

Equivalent Input Noise

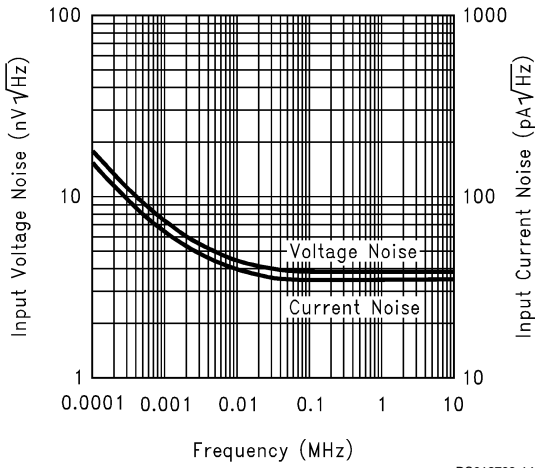

DS012798-14

Input Referred Total Noise

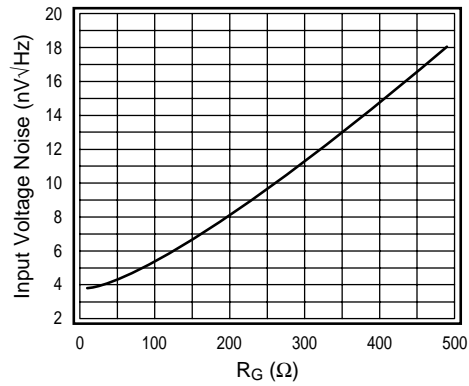

DS012798-15

Gain (V/V) vs. V_g

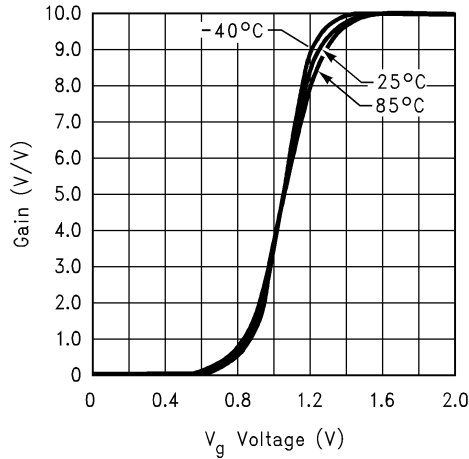

DS012798-16

Gain (dB) vs. V_g

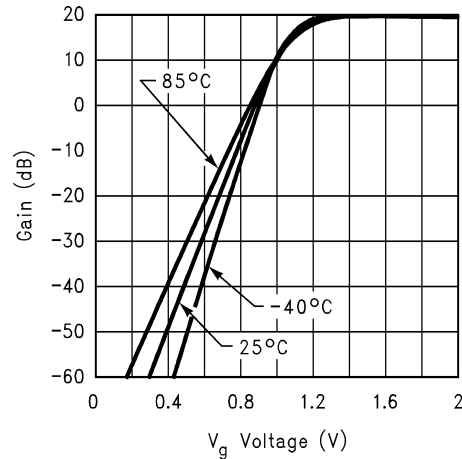

DS012798-17

Large & Small Signal Pulse Response

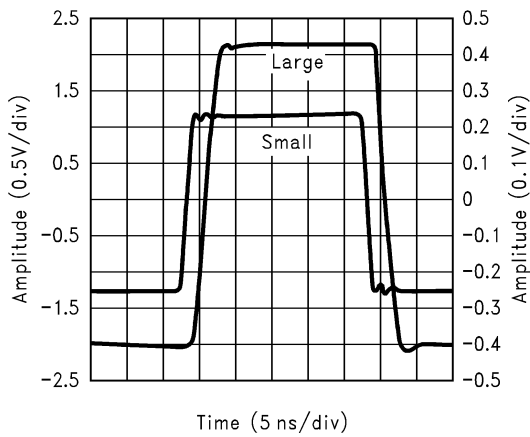

DS012798-18

2nd Harmonic Distortion vs. Frequency

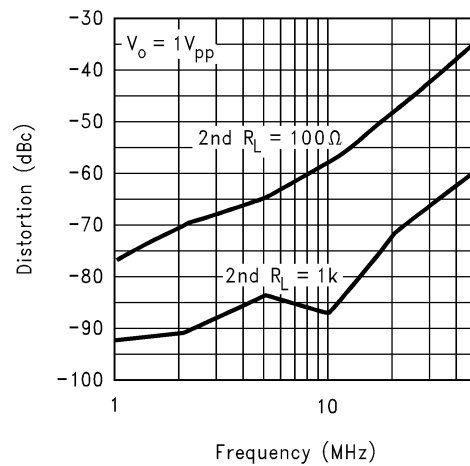

DS012798-19

Typical Performance Characteristics $V_G = +2V$, $R_f = 1k\Omega$, $R_g = 100\Omega$, $R_L = 100\Omega$, $V_O = 0.5V_{pp}$; unless specified. (Continued)

3rd Harmonic Distortion vs. Frequency

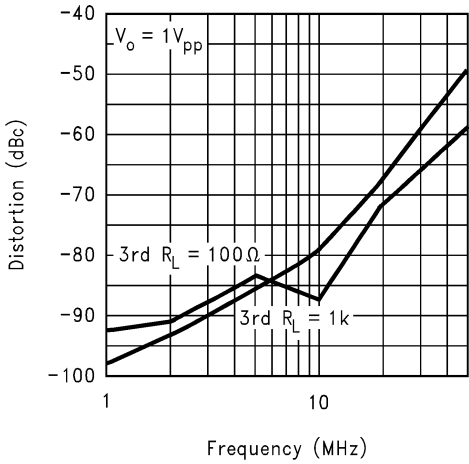

Harmonic Distortion vs. Output Voltage

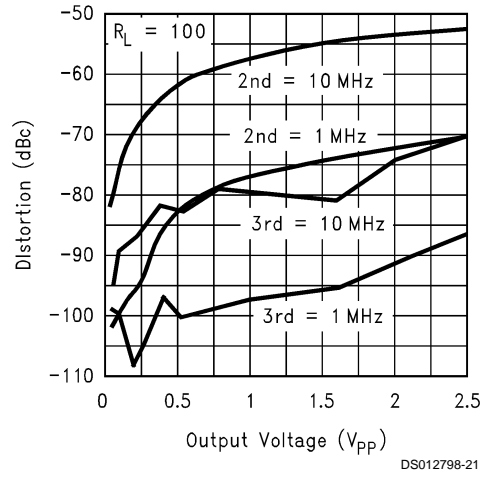

Harmonic Distortion vs. Gain

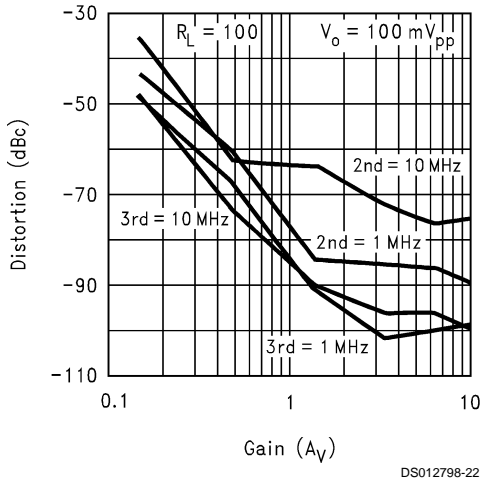

Input Harmonic Distortion ($A_V = 2$)

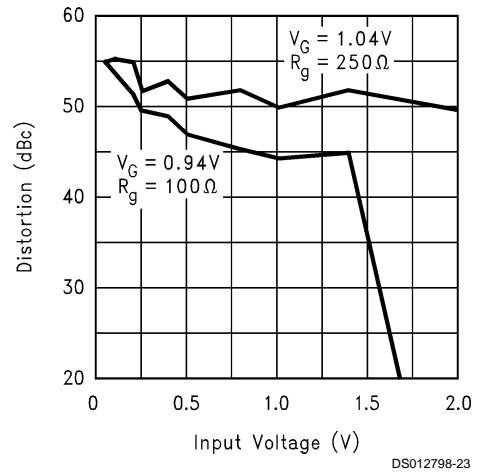

Differential Gain & Phase (NTSC)

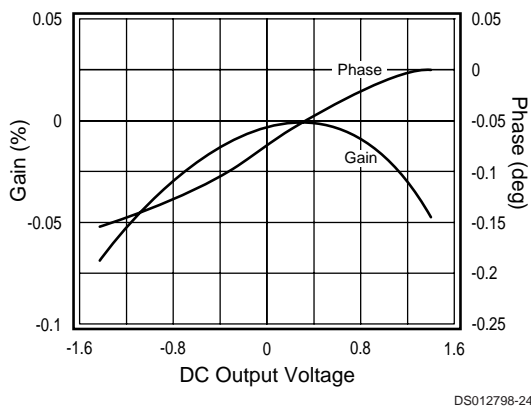

Short Term Settling Time

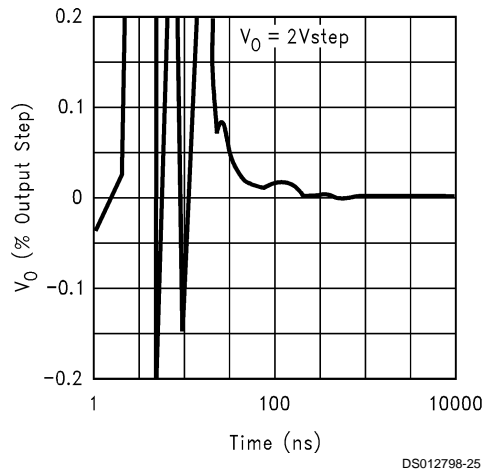

Typical Performance Characteristics $V_g = +2V$, $R_f = 1k\Omega$, $R_g = 100\Omega$, $R_L = 100\Omega$, $V_O = 0.5V_{PP}$; unless specified. (Continued)

Long Term Settling Time

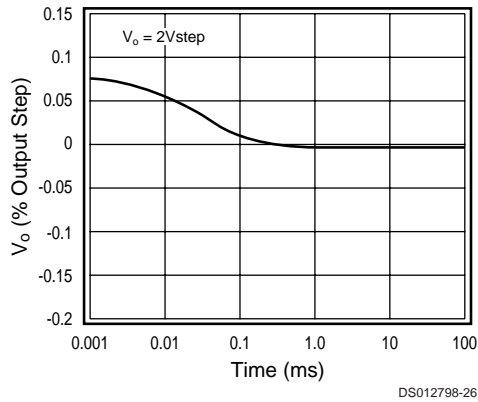

Gain Control Settling Time

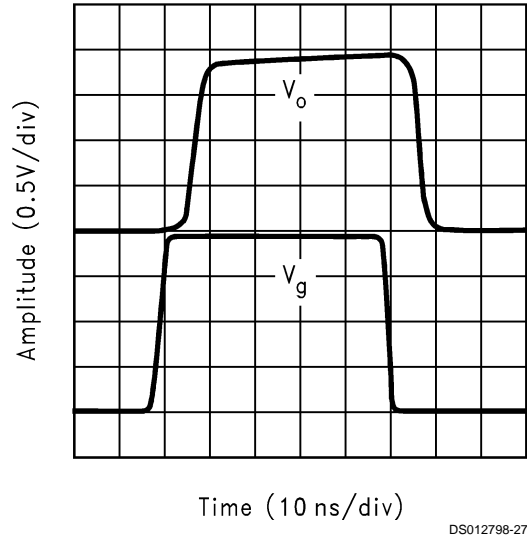

DC Offset vs. Temperature

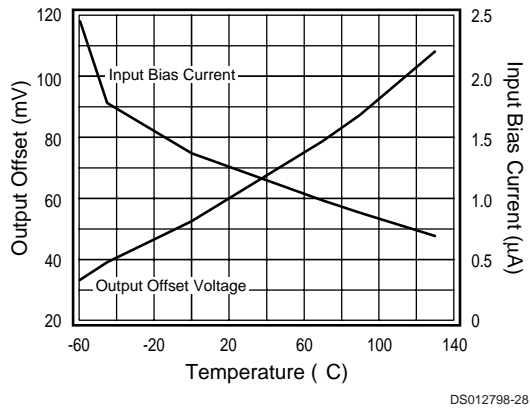

2nd Tone, 3rd Order Intermod Intercept

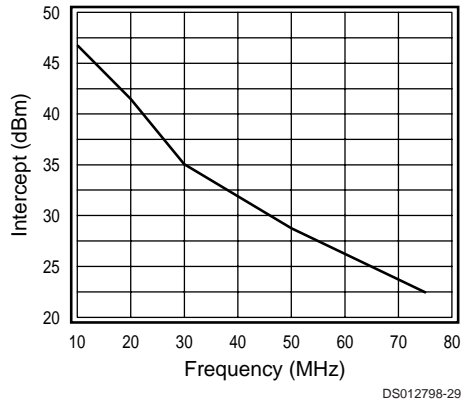

Application Division

CLC5523 Operation

The key features of the CLC5523 are:

- Low Power
- Broad voltage controlled gain and attenuation range
- Bandwidth independent, resistor programmable gain range
- Broad signal and gain control bandwidths
- Frequency response may be adjusted with R_f
- High Impedance signal and gain control inputs

The CLC5523 combines a closed loop input buffer, a voltage controlled variable gain cell and an output amplifier. The input buffer is a transconductance stage whose gain is set by the gain setting resistor, R_g . The output amplifier is a current feedback op amp and is configured as a transimpedance stage whose gain is set by, and equal to, the feedback resistor, R_f . The maximum gain, A_{vmax} , of the CLC5523 is defined by the ratio; R_f/R_g . As the gain control input (V_g) is adjusted over its 0 to 2V range, the gain is adjusted over a range of 80dB relative to the maximum set gain.

Setting the CLC5523 Maximum Gain

$$A_{vmax} = \left\{ \frac{R_f}{R_g} \right\}$$

Although the CLC5523 is specified at $A_{vmax} = 10$, the recommended A_{vmax} varies between 2 and 100. Higher gains are possible but usually impractical due to output offsets, noise and distortion. When varying A_{vmax} several tradeoffs are made:

- R_g : determines the input voltage range
- R_f : determines overall bandwidth

The amount of current which the input buffer can source into R_g is limited and is specified in the $I_{Rg,max}$ R_g spec. This sets the maximum input voltage:

$$V_{IN(max)} = I_{Rg,max} \times R_g$$

The effects of maximum input range on harmonic distortion are illustrated in the Input Harmonic Distortion plot. Variations in R_g will also have an effect on the small signal bandwidth due to its loading of the input buffer and can be seen in Frequency Response vs. R_g . Changes in R_f will have a more dramatic effect on the small signal bandwidth. The output amplifier of the CLC5523 is a current feedback amplifier (CFA) and its bandwidth is determined by R_f . As with any CFA, doubling the feedback resistor will roughly cut the bandwidth of the device in half (refer to the plot Frequency Response vs. R_f). For more information covering CFA's, there is a basic tutorial, OA-20, Current Feedback Myths Debunked or a more rigorous analysis, OA-13, Current Feedback Amplifier Loop Gain Analysis and Performance Enhancements.

Using the CLC5523 in AGC Application

In AGC applications, the control loop forces the CLC5523 to have a fixed output amplitude. The input amplitude will vary over a wide range and this can be the issue that limits dynamic range. At high input amplitudes, the distortion due to the input buffer driving R_g may exceed that which is produced by the output amplifier driving the load. In the plot, Harmonic Distortion vs. Gain, second and third harmonic distortion are plotted over a gain range of nearly 40dB for a fixed output amplitude of $100mV_{pp}$ in specified configuration,

$R_f = 1k$, $R_g = 100\Omega$. When the gain is adjusted to 0.1 (i.e., 40dB down from A_{vmax}), the input amplitude would be $1V_{pp}$ and we can see the distortion is at its worst at this gain. If the output amplitude of the AGC were to be raised above 100mV, the input amplitudes for gains 40dB down from A_{vmax} would be even higher and the distortion would degrade further. It is for this reason that we recommend lower output amplitude if wide gain range are desired. Using a post-amp like the CLC404 or CLC409 would be the best way to preserve dynamic range and yield output amplitudes much higher than $100mV_{pp}$.

Another way of addressing distortion performance and its limitations on dynamic range, would be to raise the value of R_g . Just like any other high speed amplifier, by increasing the load resistance, and therefore decreasing the demand load current, the distortion performance will be improved in most cases. With an increased R_g , R_f will also have to be increased to keep the same A_{vmax} and this will decrease the overall bandwidth.

Gain Partitioning

If high levels of gain are needed, gain partitioning should be considered.

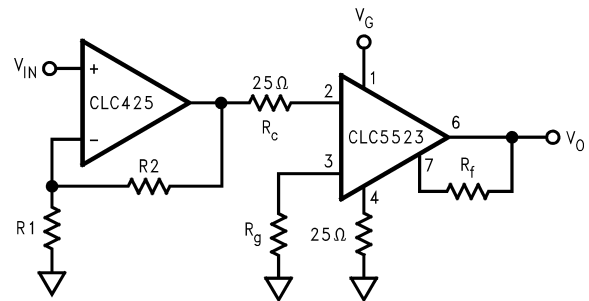

DS012798-31

FIGURE 1. Gain Partitioning

The maximum gain range for this circuit is given by the following equation:

$$\left\{ 1 + \frac{R_2}{R_1} \right\} \times \left\{ \frac{R_f}{R_g} \right\}$$

The CLC425 is a low noise wideband voltage feedback amplifier. Setting R_2 at 909 Ω and R_1 at 100 Ω produces a gain of 20dB. Setting R_f at 1000 Ω as recommended and R_g at 50 Ω , produces a gain of 26dB in the CLC5523. The total gain of this circuit is therefore approximately 46dB. It is important to understand that when partitioning to obtain high levels of gain, very small signal levels will drive the amplifiers to full scale output. For example, with 46dB of gain a 20mV signal at the input will drive the output of the CLC425 to 200mV, the output of the CLC5523 to 4V. Accordingly, the designer must carefully consider the contributions of each stage to the overall characteristics. Through gain partitioning the designer is provided with an opportunity to optimize the frequency response, noise, distortion, settling time, and loading effects of each amplifier to achieve improved overall performance.

CLC5523 Gain Control Range and Minimum Gain

Before discussing Gain Control Range, it is important to understand the issues which limit it. The minimum gain of the CLC5523, theoretically, is zero, but in practical circuits is limited by the amount of feedthrough, here defined as the

Application Division (Continued)

difference in output levels when $V_g = 2V$ and when $V_g = 0V$. Capacitance coupling through the board and package as well as coupling through the supplies will determine the amount of feedthrough. Even at DC, the input signal will not be completely rejected. At high frequencies feedthrough will get worse because of its capacitive nature. At low frequencies, the feedthrough will be 80dB below the maximum gain, and therefore it can be said that the CLC5523 has an 80dB Gain Control Range.

CLC5523 Gain Control Function

In the two plots, Gain vs. V_g , we can see the gain as a function of the control voltage. The first plot, sometimes referred to as the S-curve, is the linear (V/V) gain. This is a hyperbolic tangent relationship. The second gain curve plots the gain in dB and is linear over a wide range of gains. Because of this, the CLC5523 gain control is referred to as "linear-in-dB."

For applications where the CLC5523 will be used at the heart of a closed loop AGC circuit, the S-curve control characteristic provides a broad linear (in dB) control range with soft limiting at the highest gains where large changes in control voltage result in small changes in gain. For applications, requiring a fully linear (in dB) control characteristic, use the CLC5523 at half gain and below ($V_g \leq 1V$)

Avoiding Overdrive of the CLC5523 Gain Control Input

There is an additional requirement for the CLC5523 Gain Control Input (V_g): V_g must not exceed +2.5V. The gain control circuitry may saturate and the gain may actually be reduced. In applications where V_g is being driven from a DAC, this can easily be addressed in the software. If there is a linear loop driving V_g , such as an AGC loop, other methods of limiting the input voltage should be implemented. One simple solution is to place a 2:1 resistive divider on the V_g input. If the device driving this divider is operating off of $\pm 5V$ supplies as well, its output will not exceed 5V and through the divider V_g can not exceed 2.5V.

Improving the CLC5523 Large Signal Performance

Figure 2 illustrates an inverting gain scheme for the CLC5523.

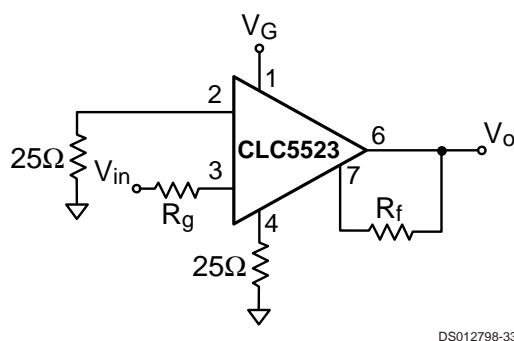

FIGURE 2. Inverting the CLC5523

The input signal is applied through the R_g resistor. The V_{in} pin should be grounded through a 25Ω resistor. The maximum gain range of this configuration is given in the following equation:

$$A_{vmax} = - \left\{ \frac{R_f}{R_g} \right\}$$

The inverting slew rate of the CLC5523 is much higher than that of the non-inverting slew rate. This 2.5X performance improvement comes about because in the non-inverting configuration, the slew rate of the overall amplifier is limited by the input buffer. In the inverting circuit, the input buffer remains at a fixed voltage and does not affect slew rate.

Transmission Line Matching

One method for matching the characteristic impedance of a transmission line is to place the appropriate resistor at the input or output of the amplifier. Figure 3 shows a typical circuit configuration for matching transmission lines.

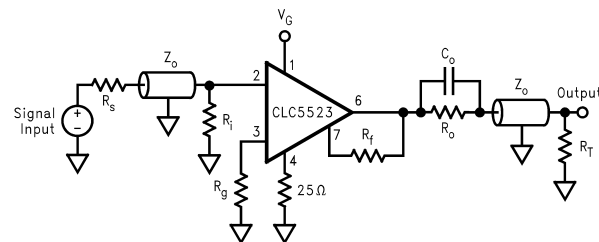

DS012798-35

FIGURE 3. Transmission Line Matching

The resistors R_s , R_i , R_o , and R_T are equal to the characteristic impedance, Z_o , of the transmission line or cable. Use C_o to match the output transmission line over a greater frequency range. It compensates for the increase of the op amp's output impedance with frequency.

Minimizing Parasitic Effects on Small Signal Bandwidth

The best way to minimize parasitic effects is to use the small outline package and surface mount components. For designs utilizing through-hole components, specifically axial resistors, resistor self-capacitance should be considered. Example: the average magnitude of parasitic capacitance of RN55D 1% metal film resistors is about 0.15pF with variations of as much as 0.1pF between lots. Given the CLC5523's extended bandwidth, these small parasitic reactance variations can cause measurable frequency response variations in the highest octave. We therefore recommend the use of surface mount resistors to minimize these parasitic reactance effects. If an axial component is preferred, we recommend PRP8351 resistors which are available from Precision Resistive Products, Inc., Highway 61 South, Mediapolis, Iowa.

Small Signal Response at Low A_{vmax}

When the maximum gain, as set by R_g and R_f , is greater than or equal to $A_{vmax}=10$, little or no peaking should be observed in the amplifier response. When the gain range is set to less than $A_{vmax} = 10$, some peaking may be observed at higher frequencies. At gain ranges of $2 A_{vmax} < 2$ peaking reaches approximately 6dB in the upper octave.

If peaking is observed with the recommended R_f resistor, and a small increase in the R_f resistor does not solve the problem, then investigate the possible causes and remedies listed below.

- **Capacitance across R_f**
- Do not place a capacitor across R_f

Application Division (Continued)

- Keep traces connecting R_f separated and as short as possible
- Capacitive Loads**
- Place a small resistor (20-50 Ω) between the output and C_L
- Long traces and/or lead lengths between R_f and the CLC5523**
- Keep these traces as short as possible
- Long traces between CLC5523 and 0.1 μ F bypass capacitors**
- Keep these traces less than 0.2 inches (5mm)
- For the devices in the PDIP package, an additional 1000pF monolithic capacitor should be placed less than 0.1" (3mm) from the pin
- Extra capacitance between the R_g pin and ground (C_g)**
- See the Printed Circuit Board Layout sub-section below for suggestions on reducing C_g
- Increase R_f if peaking is still observed after reducing C_g
- Non-inverting input pin connected directly to ground**
- Place a 50 to 200 Ω resistor between the non-inverting input pin and ground

Adjusting Offsets and DC Level Shifting

Offsets can be broken into two parts: an input-referred term and an output-referred term. These errors can be trimmed using the circuit in *Figure 4*. First set V_g to 0V and adjust the trim pot R4 to null the offset voltage at the output. This will eliminate the output stage offsets. Next set V_g to 2V and adjust the trim pot R1 to null the offset voltage at the output. This will eliminate the input stage offsets.

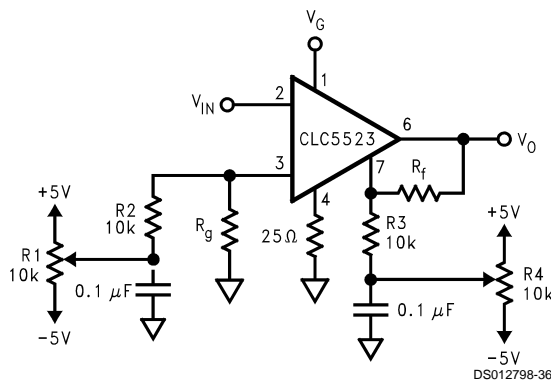

FIGURE 4. Offset Adjust Circuit

Printed Circuit Board Layout

High frequency op amp performance is strongly dependent on proper layout, proper resistive termination and adequate power supply decoupling. The most important layout points to follow are:

- Use a ground plane
- Bypass each power supply pin with these capacitors:
 - a high-quality 0.1 μ F ceramic capacitor placed less than 0.2" (5mm) from the pin
 - a 6.8 μ F tantalum capacitor less than 2" (50mm) from the pin

- for the plastic DIP package, a high-quality 1000pF ceramic capacitor placed less than 0.1" (3mm) from the pin

Capacitively bypassing power pins to a good ground plane with a minimum of trace length (inductance) is necessary for any high speed device, but it is particularly important for the CLC5523.

- Establish wide, low impedance, power supply traces
- For the plastic DIP package, a 25 Ω resistor should be connected from pin 4 to ground with a minimum length trace
- Minimize or eliminate source of capacitance between the R_f pin and the output pin. Avoid adjacent feedthrough vias between the R_f and output leads since such a geometry may give rise to a significant source of capacitance.
- Minimize trace and lead lengths for components between the inverting and output pins
- Remove ground plane 0.1" (3mm) from all input/output pads
- For prototyping, use flush-mounted printed circuit board pins; **never use high profile DIP sockets**

To minimize high frequency distortion, other layout issues need be addressed.

- Short, equal length, low impedance power supply return paths from the load to the supplies
- avoid returning output ground currents near the input stage

Evaluation Boards

Evaluation boards are available for both the 8-pin DIP and small outline package types. Free evaluation boards are shipped when a device sample request is placed with National Semiconductor. The 8-pin DIP evaluation kit part number is CLC730065. The 8-pin small outline evaluation kit part number is CLC730066.

The DIP evaluation kit has been designed to utilize axial lead components. The small outline evaluation kit has been designed to utilize surface mount components.

The circuit diagram shown in *Figure 5*, applies to both the DIP and the small outline evaluation boards.

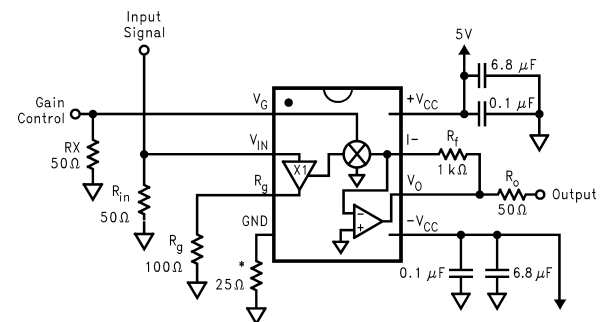

* 25 Ω series resistor is not required on the small outline device and does not appear on the small outline board

DS012798-37

FIGURE 5. Evaluation Board Schematic

Application Division (Continued)

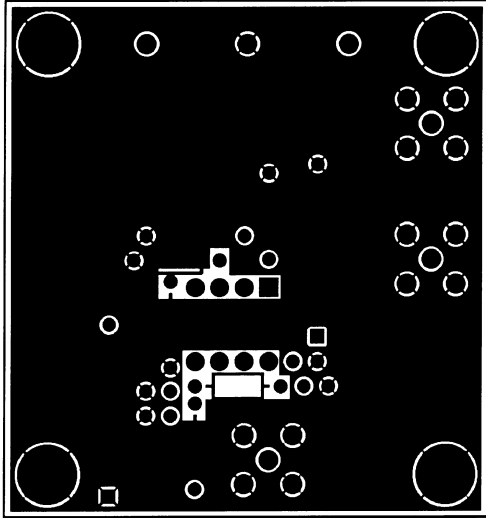

DS012798-38

FIGURE 6. DIP Evaluation Board (Top Layer)

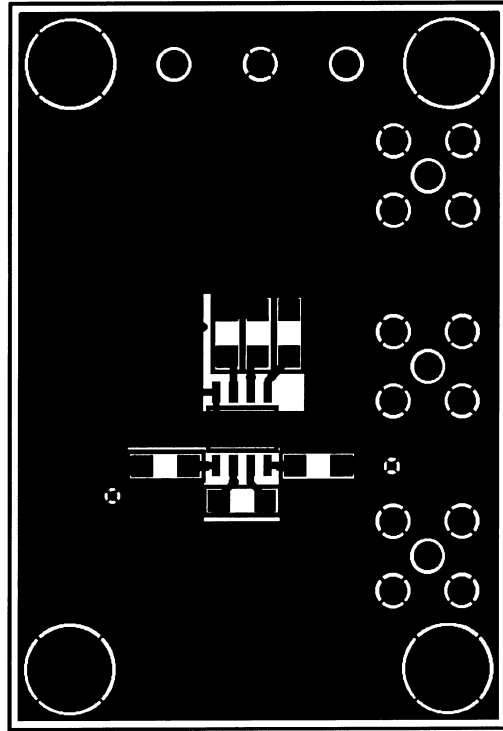

DS012798-40

FIGURE 8. Small Outline Evaluation Board (Top Layer)

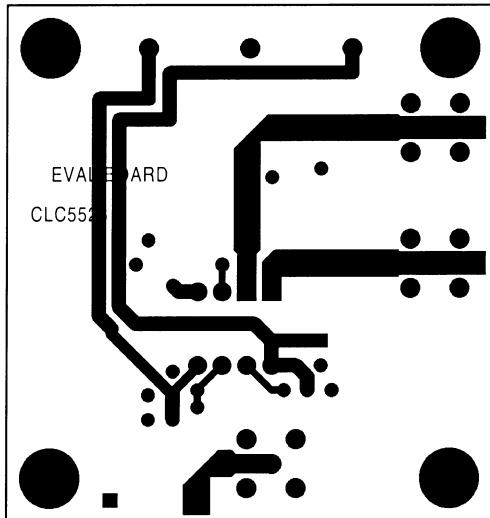

DS012798-39

FIGURE 7. DIP Evaluation Board (Bottom Layer)

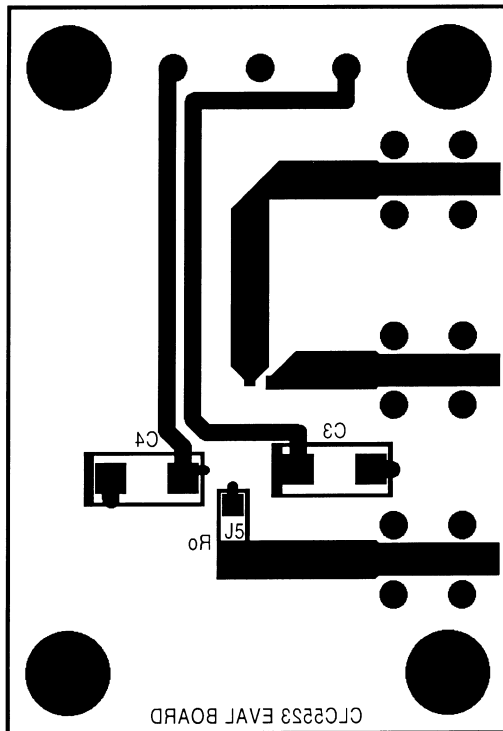

DS012798-41

FIGURE 9. Small Outline Evaluation Board (Bottom Layer)

Application Division (Continued)

Digital Gain Control

Digitally variable gain control can be easily realized by driving the CLC5523's gain control input with a digital-to-analog

converter (DAC). *Figure 10* illustrates such an application. This circuit employs National Semiconductor's eight-bit DAC0830, the LM351 JFET input op amp, and the CLC5523 VGA. With V_{ref} set to 2V, the circuit provides up to 0.05% full scale resolution. The maximum gain of this circuit is 20dB.

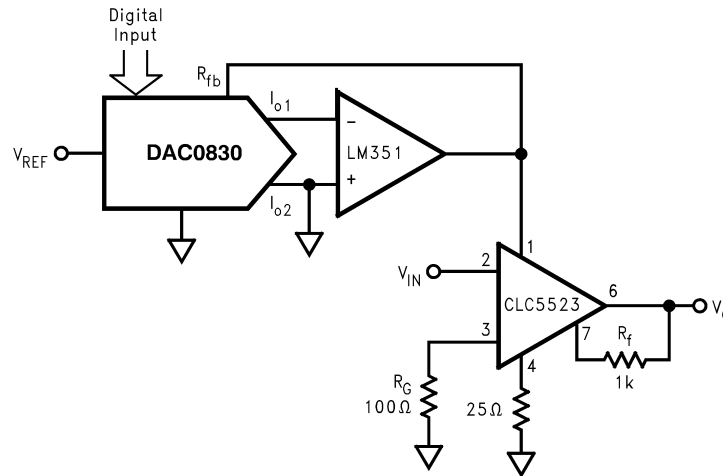

DS012798-42

FIGURE 10. Digital Gain Control

Fast Response AGC Loop

The AGC circuit shown in *Figure 11* will correct a 6dB input amplitude step in 100ns. The circuit includes a two op-amp precision rectifier amplitude detector (U1 and U2), and an integrator (U3) to provide high loop gain at low frequencies. The output amplitude is set by R9.

Some notes on building fast AGC loops:

Precision rectifiers work best with large output signals. Accuracy is improved by blocking DC offsets, as shown in *Figure 11*.

Signal frequencies must not reach the gain control port of the CLC5523, or the output signal will be distorted (modulated by itself). A fast settling AGC needs additional filtering beyond the integrator stage to block signal frequencies. This is provided in *Figure 11* by a simple R-C filter (R10 and C3); better distortion performance can be achieved with a more complex filter. These filters should be scaled with the input signal frequency. Loops with slower response time (longer integration time constants) may not need the R10 - C3 filter.

Checking the loop stability can be done by monitoring the V_g voltage while applying a step change in input signal ampli-

tude. Changing the input signal amplitude can be easily done with either an arbitrary waveform generator or a fast multiplexer such as the CLC532.

Automatic Gain Control (AGC) #2

Figure 12 on the following page, illustrates an automatic gain control circuit that employs two CLC5523's. In this circuit, U1 receives the input signal and produces an output signal of constant amplitude. U2 is configured to provide negative feedback. U2 generates a rectified gain control signal that works against an adjustable bias level which may be set by the potentiometer and R_b . C_i integrates the bias and negative feedback. The resultant gain control signal is applied to the U1 gain control input V_g . The bias adjustment allows the U1 output to be set at an arbitrary level less than the maximum output specification of the amplifier. Rectification is accomplished in U2 by driving both the amplifier input and the gain control input with the U1 output signal. The voltage divider that is formed by R1, R2 and the V_g input (pin 1) resistance, sets the rectifier gain.

Physical Dimensions inches (millimeters) unless otherwise noted

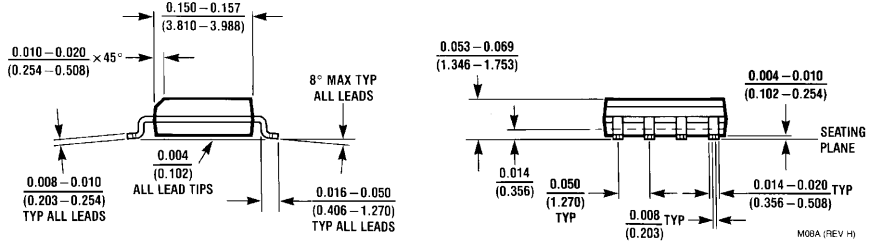
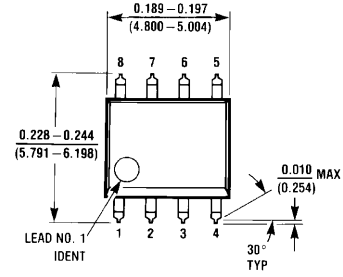

8-Pin SOIC
NS Package Number M08A

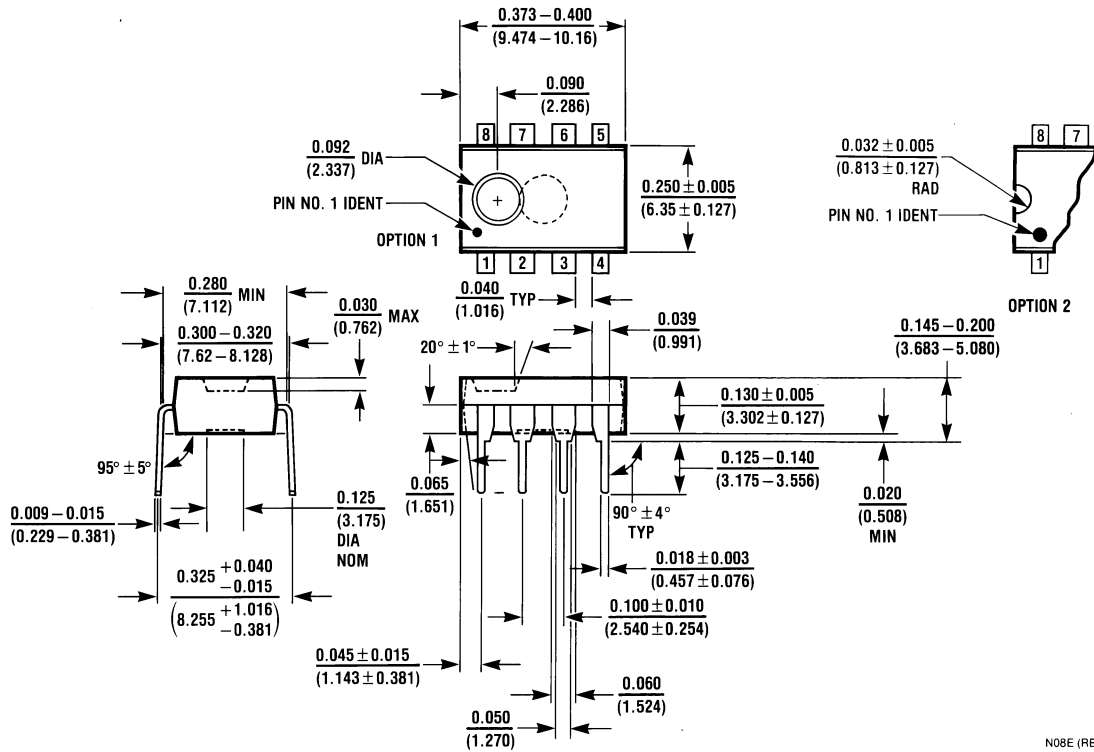

8-Pin MDIP
NS Package Number N08E

Notes

LIFE SUPPORT POLICY

NATIONAL'S PRODUCTS ARE NOT AUTHORIZED FOR USE AS CRITICAL COMPONENTS IN LIFE SUPPORT DEVICES OR SYSTEMS WITHOUT THE EXPRESS WRITTEN APPROVAL OF THE PRESIDENT AND GENERAL COUNSEL OF NATIONAL SEMICONDUCTOR CORPORATION. As used herein:

1. Life support devices or systems are devices or systems which, (a) are intended for surgical implant into the body, or (b) support or sustain life, and whose failure to perform when properly used in accordance with instructions for use provided in the labeling, can be reasonably expected to result in a significant injury to the user.
2. A critical component is any component of a life support device or system whose failure to perform can be reasonably expected to cause the failure of the life support device or system, or to affect its safety or effectiveness.



National Semiconductor Corporation
Americas
Email: support@nsc.com

www.national.com

National Semiconductor Europe

Fax: +49 (0) 180-530 85 86
Email: europe.support@nsc.com
Deutsch Tel: +49 (0) 69 9508 6208
English Tel: +44 (0) 870 24 0 2171
Français Tel: +33 (0) 1 41 91 8790

National Semiconductor Asia Pacific Customer Response Group

Tel: 65-2544466
Fax: 65-2504466
Email: ap.support@nsc.com

National Semiconductor Japan Ltd.

Tel: 81-3-5639-7560
Fax: 81-3-5639-7507

National Semiconductor was acquired by Texas Instruments.

http://www.ti.com/corp/docs/investor_relations/pr_09_23_2011_national_semiconductor.html

This file is the datasheet for the following electronic components:

CLC5523 - <http://www.ti.com/product/clc5523?HQS=TI-null-null-dscatalog-df-pf-null-ww>



LittleDiode supplies new, hard to find or obsolete electronic components and semiconductors all over the world.

With over two million different components listed you are sure to find the part you need.

Feel free to visit us today at our online store:

LittleDiode.com

Looking forward to providing you with the best possible service.