

**SINGLE PHASE HALL EFFECT LATCH****AH477A****General Description**

The AH477A is an integrated Hall sensor with H-bridged output driver designed for brushless DC motor applications. The device includes an on-chip Hall sensor for magnetic sensing, an amplifier that amplifies the Hall voltage, a comparator to provide switching hysteresis for noise rejection, a bi-directional drivers for sinking and driving large current load. It also includes an internal bandgap regulator to provide temperature compensated bias for internal circuits and allows a wide operating supply voltage range.

Placing the device in a variable magnetic field, if the magnetic flux density is larger than threshold  $B_{OP}$ , the DO is turned to sink and DOB is turned to drive. This output state is held until the magnetic flux density reverses and falls below  $B_{RP}$ , then causes DO to be turned to drive and DOB turned to sink.

The AH477A is available in TO-94 (SIP-4L) package.

**Features**

- On-Chip Hall Sensor
- Operating Voltage: 3.5V to 18V
- H-Bridge Output Drivers for Single Coil
- Internal Bandgap Regulator for Temperature Compensation
- Low Output Switching Current Noise
- Operating Temperature: -20°C to 85°C
- Low Profile TO-94 (SIP-4L) Package
- ESD Rating: 6000V (Human Body Model)
- Suitable for PWM Power Supply Control Speed

**Applications**

- Single-coil Brushless DC Motor
- Single-coil Brushless DC Fan

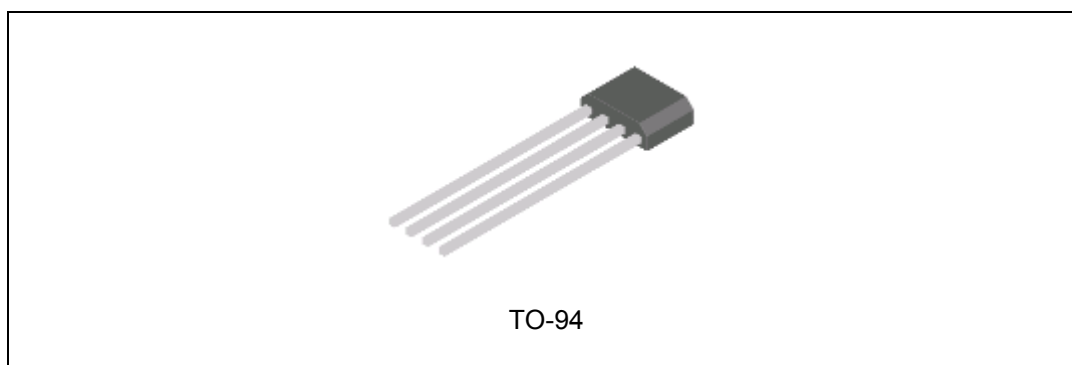

Figure 1. Package Type of AH477A

**SINGLE PHASE HALL EFFECT LATCH**

**AH477A**

**Pin Configuration**

Z4 Package  
(TO-94)

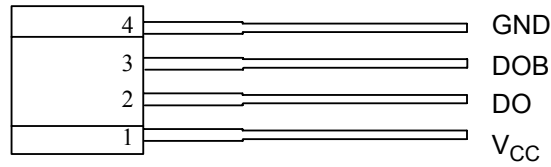

Figure 2. Pin Configuration of AH477A (Front View)

**Pin Description**

Pin Number	Pin Name	Function
1	V <sub>CC</sub>	Supply voltage
2	DO	Output 1
3	DOB	Output 2
4	GND	Ground



**SINGLE PHASE HALL EFFECT LATCH****AH477A****Absolute Maximum Ratings (Note 1)** $(T_A=25^{\circ}\text{C})$ 

Parameter	Symbol	Value	Unit
Supply Voltage	$V_{CC}$	20	V
Magnetic Flux Density	B	Unlimited	Gauss
Output Current	Continuous	250	mA
	Hold	300	mA
	Peak (start up)	600	mA
Power Dissipation	$P_D$	550	mW
Thermal Resistance	Die to atmosphere	$\theta_{JA}$	227 $^{\circ}\text{C}/\text{W}$
	Die to package case	$\theta_{JC}$	49 $^{\circ}\text{C}/\text{W}$
Storage Temperature	$T_{STG}$	-50 to 150	$^{\circ}\text{C}$
ESD (Machine Model)		600	V
ESD (Human Body Model)		6000	V

Note 1: Stresses greater than those listed under "Absolute Maximum Ratings" may cause permanent damage to the device. These are stress ratings only, and functional operation of the device at these or any other conditions beyond those indicated under "Recommended Operating Conditions" is not implied. "Absolute Maximum Ratings" for extended period may affect device reliability.

**Recommended Operating Conditions** $(T_A=25^{\circ}\text{C})$ 

Parameter	Symbol	Min	Max	Unit
Supply Voltage	$V_{CC}$	3.5	18	V
Frequency (PWM Power)	f	0.1	25	kHz
Ambient Temperature	$T_A$	-20	85	$^{\circ}\text{C}$



**SINGLE PHASE HALL EFFECT LATCH**

**AH477A**

**Electrical Characteristics**

( $T_A=25^{\circ}C$ ,  $V_{CC}=14V$ , unless otherwise specified)

Parameter	Symbol	Test Condition	Min	Typ	Max	Unit
Output Saturation Voltage (Sink)	$V_{SAT}$	$V_{CC}=14V, I_O=200mA$		0.45	0.65	V
Output Saturation Voltage (Drive)		$V_{CC}=14V, I_O=200mA$	$V_{CC}-1.3$	$V_{CC}-1.0$	$V_{CC}$	V
Supply Current	$I_{CC}$	$V_{CC}=20V$ , Output Open		13.5	16	mA
Output Rise Time	$t_r$	$R_L=820\Omega, C_L=20pF$		0.5	1.0	$\mu s$
Output Fall Time	$t_f$	$R_L=820\Omega, C_L=20pF$		0.5	1.0	$\mu s$

**Magnetic Characteristics**

( $T_A=25^{\circ}C$ )

Parameter	Symbol	Grade	Min	Typ	Max	Unit
Operating Point	$B_{OP}$	A	5		70	Gauss
		B			100	
Releasing Point	$B_{RP}$	A	-70		-5	Gauss
		B	-100			
Hysteresis	$B_{HYS}$			70		Gauss

**Test Circuit**

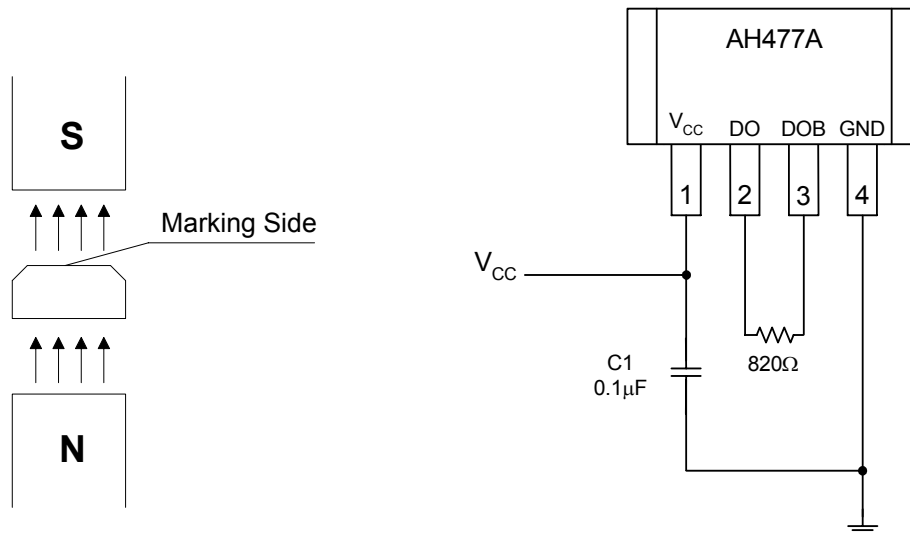



**SINGLE PHASE HALL EFFECT LATCH**

**AH477A**

**Magnetic Hysteresis Characteristics**

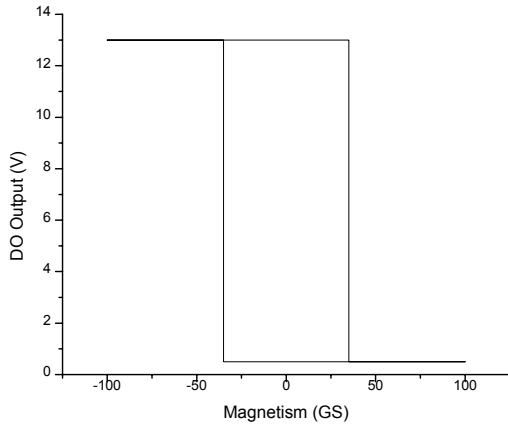

Figure 4. DO Output vs. Magnetism

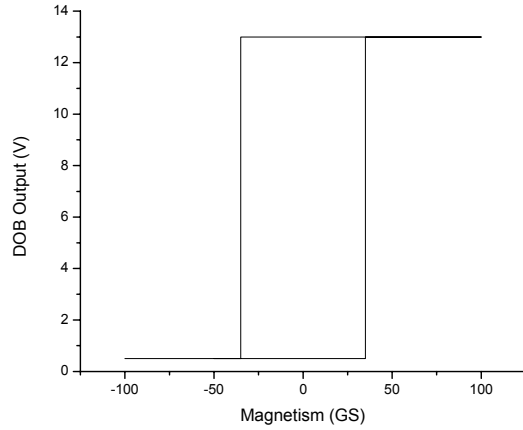

Figure 5. DOB Output vs. Magnetism

**Typical Performance Characteristics**

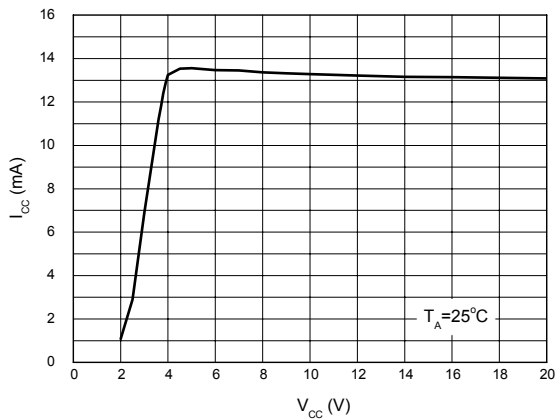

Figure 6. Supply Current vs. Supply Voltage

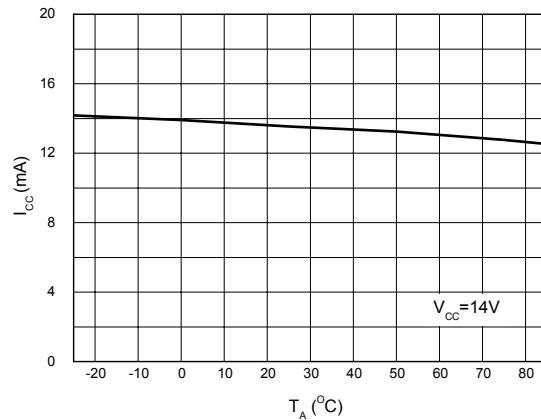

Figure 7. Supply Current vs. Ambient Temperature



**SINGLE PHASE HALL EFFECT LATCH**

**AH477A**

**Typical Performance Characteristics (Continued)**

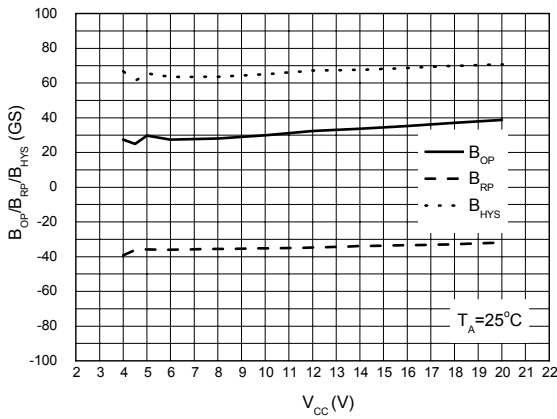

Figure 8.  $B_{OP}/B_{RP}/B_{HYS}$  vs. Supply Voltage

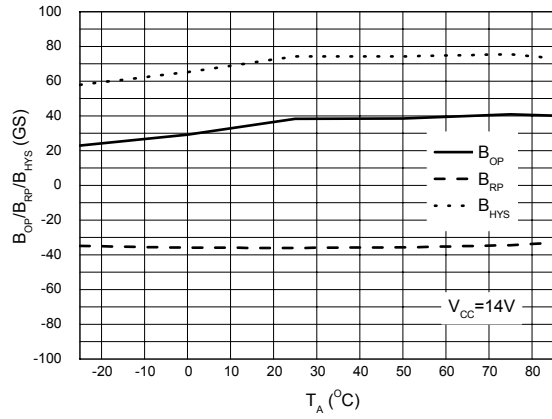

Figure 9.  $B_{OP}/B_{RP}/B_{HYS}$  vs. Ambient Temperature

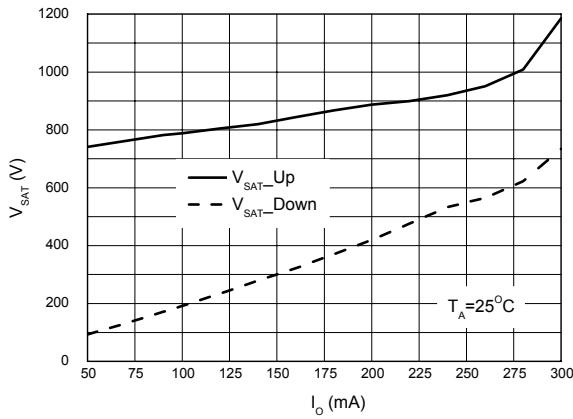

Figure 10.  $V_{SAT}$  vs.  $I_O$

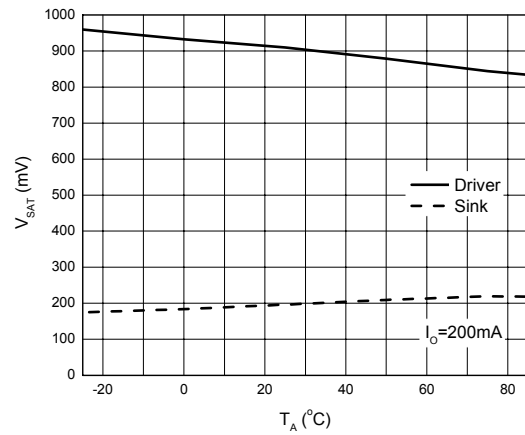

Figure 11.  $V_{SAT}$  vs. Ambient Temperature

**SINGLE PHASE HALL EFFECT LATCH**

**AH477A**

**Typical Performance Characteristics (Continued)**

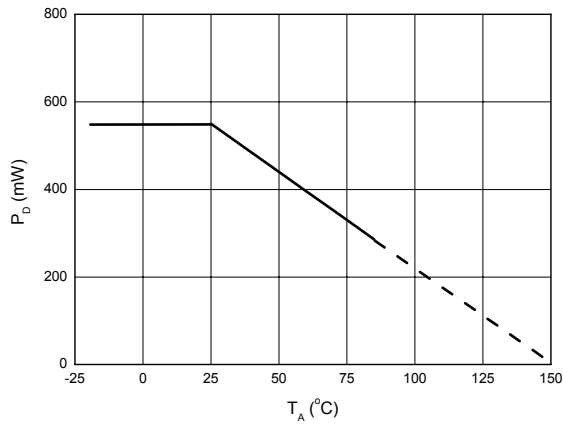

Figure 12. P<sub>D</sub> vs. Ambient Temperature

**Typical Application**

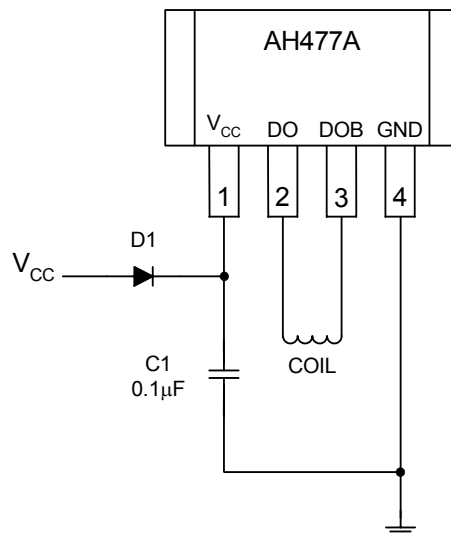

Figure 13. Typical Application Circuit



**SINGLE PHASE HALL EFFECT LATCH**

**AH477A**

**Mechanical Dimensions**

**TO-94**

**Unit: mm(inch)**

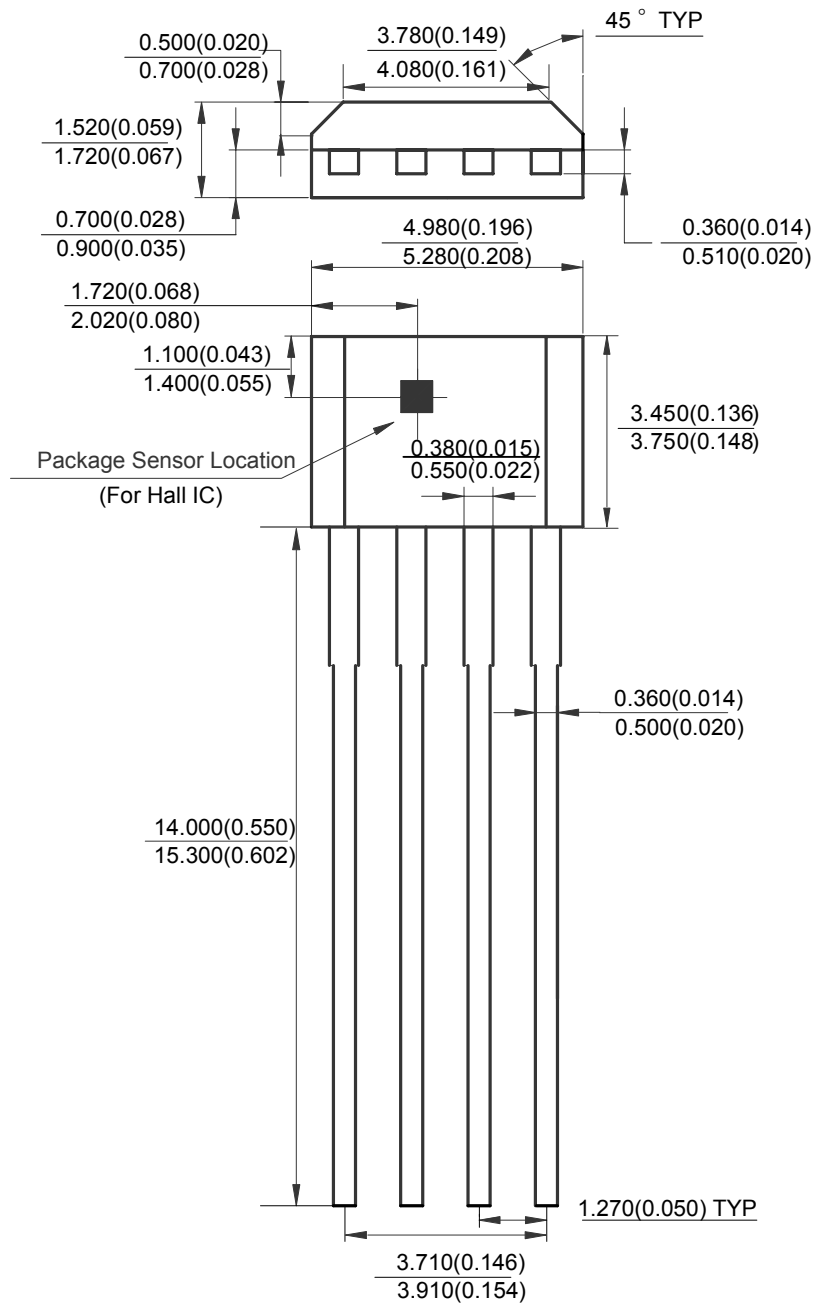



## **BCD Semiconductor Manufacturing Limited**

<http://www.bcdsemi.com>

### **IMPORTANT NOTICE**

BCD Semiconductor Manufacturing Limited reserves the right to make changes without further notice to any products or specifications herein. BCD Semiconductor Manufacturing Limited does not assume any responsibility for use of any its products for any particular purpose, nor does BCD Semiconductor Manufacturing Limited assume any liability arising out of the application or use of any its products or circuits. BCD Semiconductor Manufacturing Limited does not convey any license under its patent rights or other rights nor the rights of others.

---

#### **MAIN SITE**

##### **- Headquarters**

##### **BCD Semiconductor Manufacturing Limited**

No. 1600, Zi Xing Road, Shanghai Zizhu Science-based Industrial Park, 200241, China  
Tel: +86-21-24162266, Fax: +86-21-24162277

##### **- Wafer Fab**

##### **Shanghai SIM-BCD Semiconductor Manufacturing Co., Ltd.**

800 Yi Shan Road, Shanghai 200233, China  
Tel: +86-21-6485 1491, Fax: +86-21-5450 0008

#### **REGIONAL SALES OFFICE**

##### **Shenzhen Office**

##### **Shanghai SIM-BCD Semiconductor Manufacturing Co., Ltd., Shenzhen Office**

Unit A Room 1203, Skyworth Bldg., Gaoxin Ave. 1.S., Nanshan District, Shenzhen, China  
Tel: +86-755-8826 7951  
Fax: +86-755-8826 7865

##### **Taiwan Office**

##### **BCD Semiconductor (Taiwan) Company Limited**

4F, 298-1, Rui Guang Road, Nei-Hu District, Taipei, Taiwan  
Tel: +886-2-2656 2808  
Fax: +886-2-2656 2806

##### **USA Office**

##### **BCD Semiconductor Corp.**

30920 Huntwood Ave. Hayward, CA 94544, USA  
Tel : +1-510-324-2988  
Fax: +1-510-324-2788



LittleDiode supplies new, hard to find or obsolete electronic components and semiconductors all over the world.

With over two million different components listed you are sure to find the part you need.

Feel free to visit us today at our online store:

[LittleDiode.com](http://LittleDiode.com)

Looking forward to providing you with the best possible service.