

GaAs MMIC

Data Sheet

CMY 210

- Ultralinear Mixer with integrated LO-Buffer
- Very high Input-IP3 of typical 24 dBm
- Very low LO-Power demand of typ. 0 dBm
- Suited for Up- and Down-Conversion
- Wide LO-Frequency Range < 500 MHz to > 2.5 GHz
- Wide LO-Level Range
- Single ended Ports
- RF- and IF-Port Impedance 50 Ω
- Operating Voltage Range: < 3 to 6 V
- Very low Current Consumption of typical 6 mA
- All Gold Metallization

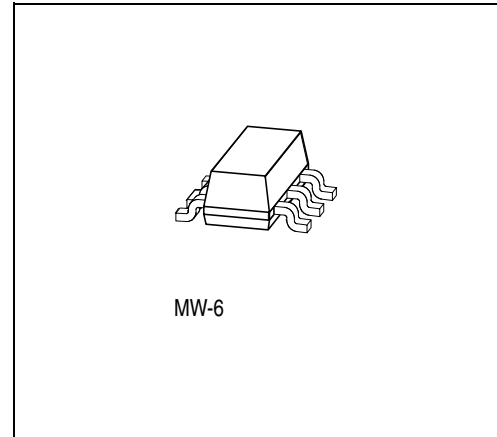

ESD: Electrostatic discharge sensitive device
Observe handling Precautions!

Type	Marking	Ordering Code (tape and reel)	Package ¹⁾
CMY 210	M3	Q62702-M0016	MW-6

¹⁾ For detailed dimensions see **Page 10**.

Maximum Ratings

Parameter	Port	Symbol	Limit Values		Unit
			min.	max.	
Supply Voltage	4	V_{DD}	0	6	V
DC-Voltage at LO Input	3	V_3	- 3	0.5	V
DC-Voltage at RF-IF Ports ¹⁾	1, 6	$V_{1,6}$	- 0.5	+ 0.5	V
Power into RF-IF Ports	1, 6	$P_{IN,RF}$	-	17	dBm
Power into LO Input	3	$P_{IN,LO}$	-	10	dBm
Channel Temperature	-	T_{Ch}	-	150	°C
Storage Temperature	-	T_{stg}	- 55	150	°C

¹⁾ For DC test purposes only, no DC voltages at pins 1, 6 in application.

Thermal Resistance

Parameter	Symbol	Value	Unit
Channel to Soldering Point (GND)	R_{thChS}	≤ 100	K/W

Electrical Characteristics

$T_A = 25\text{ }^\circ\text{C}$; $V_{DD} = 3\text{ V}$, see test circuit; $f_{RF} = 808\text{ MHz}$; $f_{LO} = 965\text{ MHz}$; $P_{LO} = 0\text{ dBm}$; $f_{IF} = 157\text{ MHz}$, unless otherwise specified.

Parameters	Symbol	Limit Values			Unit	Test Conditions
		min.	typ.	max.		
Operating Current	I_{OP}	–	6.0	8.0	mA	–
Conversion Loss	L_C	–	5.7	7.0	dB	–
SSB Noise Figure	F_{SSB}	–	6.0	–	dB	–
2 Tone 3 rd Order IMD	d_{IM3}	–	54	–	dBc	$P_{RF1} = -3\text{ dBm}$ $P_{RF2} = -3\text{ dBm}$ $f_{RF1} = 806\text{ MHz}$; $f_{RF2} = 810\text{ MHz}$; $f_{LO} = 965\text{ MHz}$
3 rd Order Input Intercept Point	$IP3_{IN}$	20	24	–	dBm	–
Input Power	$P_{-1\text{ dB}}$	–	14	–	dBm	–
LO Leakage at RF/IF-Port (1, 6)	$P_{LO\ 1,6}$	–	–8	–	dBm	–

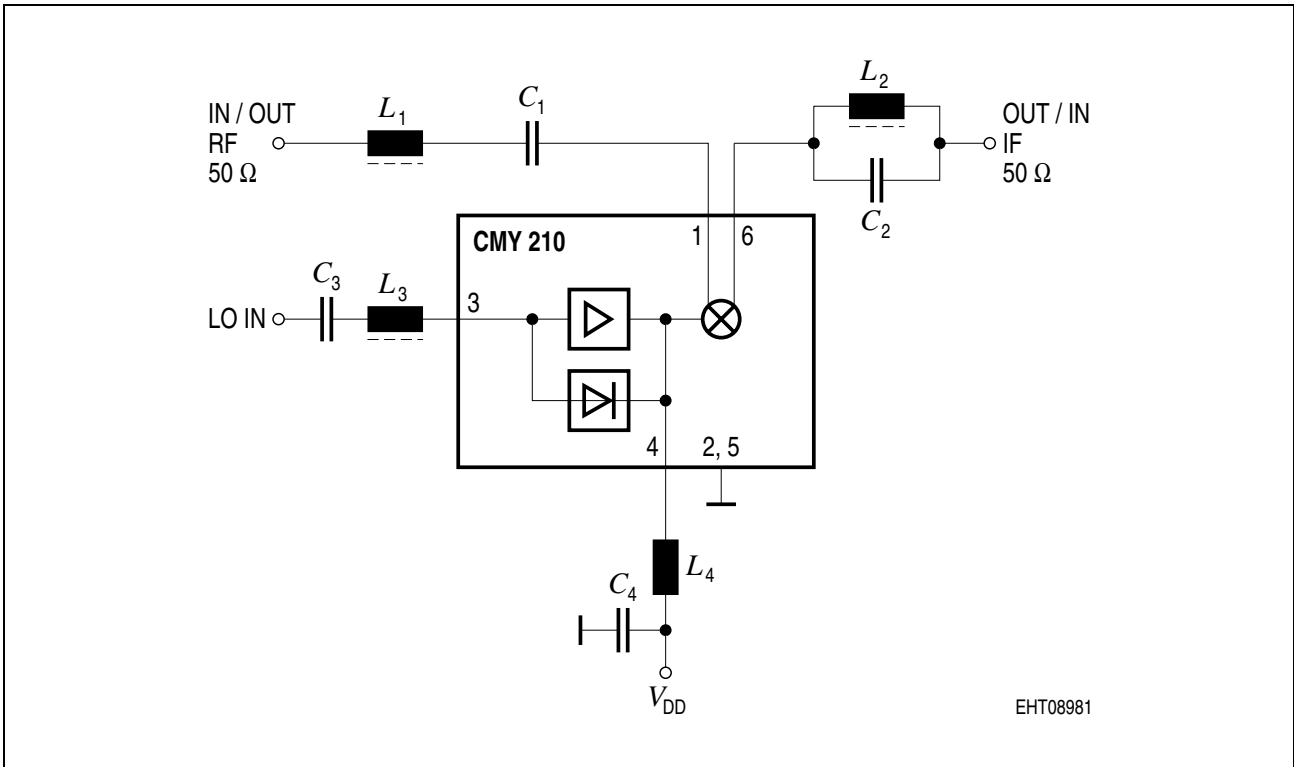

EHT08981

Figure 1 Test Circuit/Application Example

Notes for External Elements

L_1, C_1 : Filter for upper frequency.

C_2, L_2 : Filter for lower frequency.

Each filter is a throughpath for the desired frequency (RF or IF) and isolates the other frequency (IF or RF) and its harmonics.

These two filters must be connected to pin 1 and pin 6 directly.

Parasitic capacitances at the ports 1 and 6 must be as small as possible.

L_4 and C_4 are optimized by indicating lowest I_{OP} at used LO-frequency; same procedure for L_3 .

The ports 1, 3 and 6 must be DC open.

Lumped Element Values for 800 MHz Test and Application Circuit

f_{LO}	F_{RF}	F_{IF}	L_1	C_1	L_2	C_2	L_3	C_3	L_4	C_4
MHz	MHz	MHz	nH	pF	nH	pF	nH	pF	nH	pF
965	808	157	8.2	3.9	8.2	3.3	6.8	47	15	33

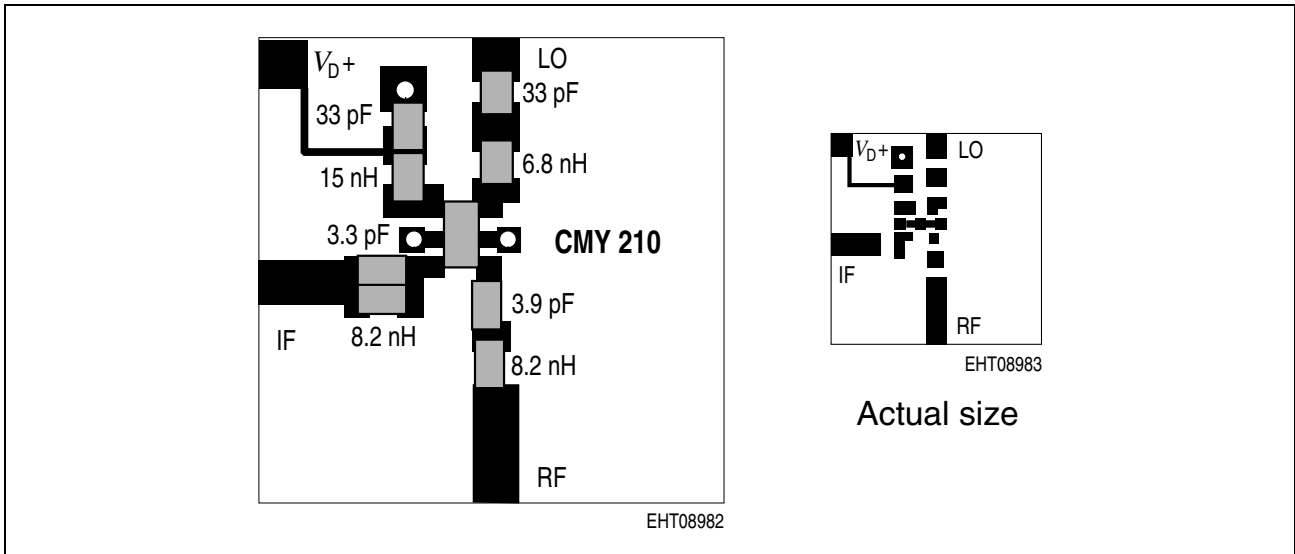

Figure 2 PCB-Layout for 800 MHz Test and Application Circuit

Typical Lumped Element Values for Different RF-Frequencies

f_{RF}	L_1	C_1	L_2	C_2
MHz	nH	pF	nH	pF
400	12	15	12	12
450	12	12	12	10
900	8.2	3.9	8.2	3.3
1500	3.3	2.7	3.3	2.2
1800	3.3	2.2	3.3	1.8
2000	3.3	1.8	3.3	1.2
2400	1.8	2.7	1.8	1.5

Typical Lumped Element Values for Different LO-Frequencies

f_{LO}	L_3	C_3	L_4	C_4
MHz	nH	pF	nH	pF
500	15	82	47	82
750	6.8	33	22	33
800	6.8	33	18	33
950	6.8	27	15	27

Typical Lumped Element Values for Different LO-Frequencies (cont'd)

f_{LO}	L_3	C_3	L_4	C_4
MHz	nH	pF	nH	pF
1100	6.8	27	12	27
1400	6.8	22	6.8	22
1600	6.8	18	4.7	18
1800	6.8	15	3.3	15
2000	6.8	12	2.2	12
2100	6.8	12	1.8	12
2300	4.7	12	1.2	12

General Description and Notes

The CMY 210 is an all port single ended general purpose Up- and Down-Converter. It combines small conversion losses and excellent intermodulation characteristics with a low demand of LO- and DC-power.

The internal level controlled LO-Buffer enables a good performance over a wide LO level range.

The internal mixers principle with one port RF and IF requires a frequency separation at pin 1 and 6 respectively.

Note 1

Best performance with lowest conversion loss is achieved when each circuit or device for the frequency separation meets the following requirements:

Input Filter: Throughpass for the signal to be mixed; reflection of the mixed signal and the harmonics of both.

Output Filter: Throughpass for the mixed signal and reflection of the signal to be mixed and the harmonics of both.

The impedance for the reflecting frequency range of each filter toward the ports 1 and 6 should be as high as possible.

In the simplest case a series- and a parallel- resonator circuit will meet these requirements but also others as appropriate drop in filters or micro stripline elements can be used.

The two branches with filters should meet immediately at the package leads of the port 1 and 6.

Parasitic capacitances at these ports must be kept as small as possible.

The mixer also can be driven with a source- and a load impedance different to 50 Ω , but performance will degrade at larger deviations.

Note 2

The LO-Buffer needs an external inductor L_4 at port 4; the value of inductance depends on the LO frequency. It is tuned for minimum I_{OP} consumption into port 4. At lower LO frequencies it can be reduced by an additional capacitor C_5 .

Note 3

The LO Input impedance at Port 3 can be matched with a series inductor. It also can be tuned for a minimum current I_{OP} into port 4. C_3 is a DC blocking capacitor. Since the input impedance of port 3 can be slightly negative at lower frequencies, the source reflection coefficient should be kept below 0.8 ($Z_0 = 50 \Omega$) within this frequency range.

The Conversion Noise Figure F_{SSB} is corresponding with the value of Conversion Loss L_C . The LO signal must be clean of noise and spurious at the frequencies $f_{LO} \pm f_F$.

Operating Current $I_{OP} = f(P_{LO})$,
 $V_{DD} = 3\text{ V}$, $f_{LO} = \text{Parameter}$

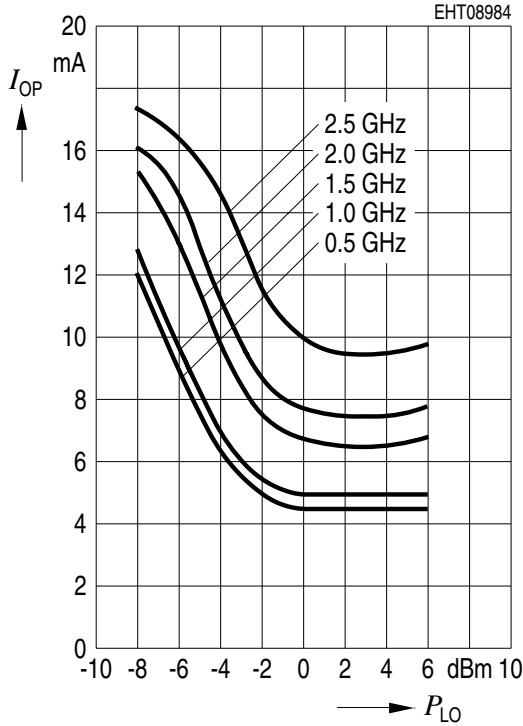

Conversion Loss $L_C = f(P_{LO})$, $V_{DD} = 3\text{ V}$,
 $f_{IF} = 120\text{ MHz}$, $f_{LO} = \text{Parameter}$

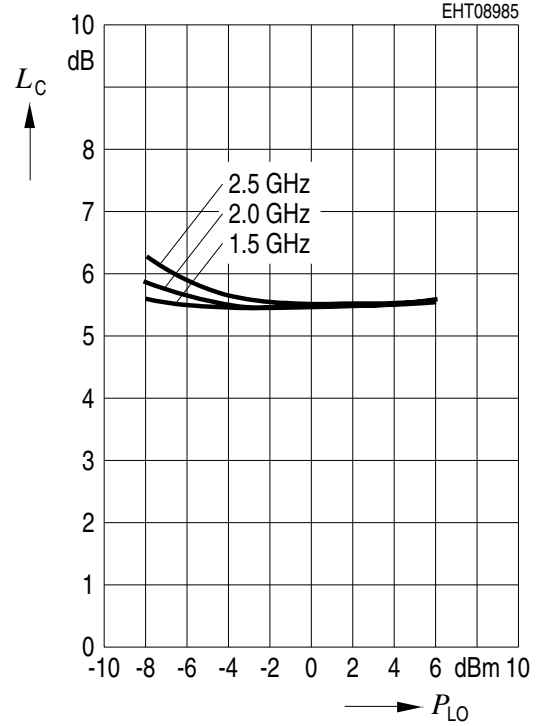

Conversion Loss $L_C = f(V_{DD})$,
 $P_{LO} = 0\text{ dBm}$, $f_{LO} = 1500\text{ MHz}$;
 $f_{IF} = 120\text{ MHz}$

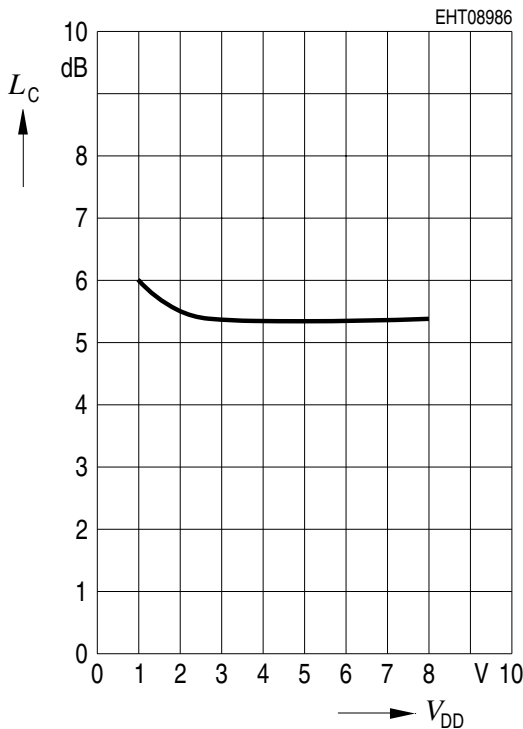

Third Order IP3 $IP3_{IN} = f(P_{LO})$,
 $P_{IN} = 2 \times -3\text{ dBm}$; $f_{IF} = 40/45\text{ MHz}$,
 $V_{DD} = 3\text{ V}$; $f_{LO} = \text{Parameter}$

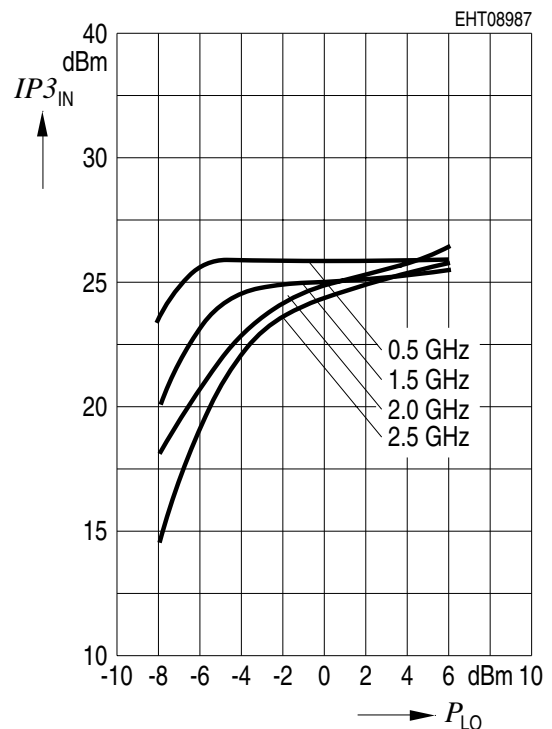

Operating Current $I_{OP} = f(V_{DD})$,
 $P_{LO} = 0$ dBm, $f_{LO} = 1500$ MHz

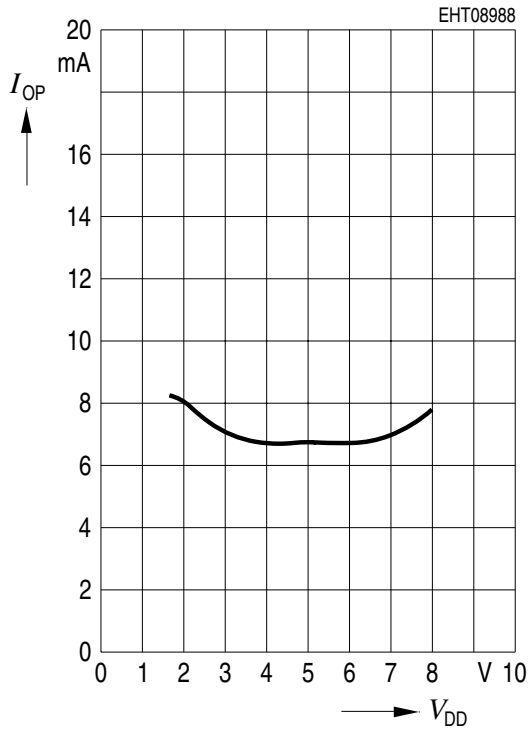

LO-Leakage at Port 1, 6
 $P_{LO1,6} = f(f_{LO})$, $P_{LO} = 0$ dBm,
 $V_{DD} = 3$ V

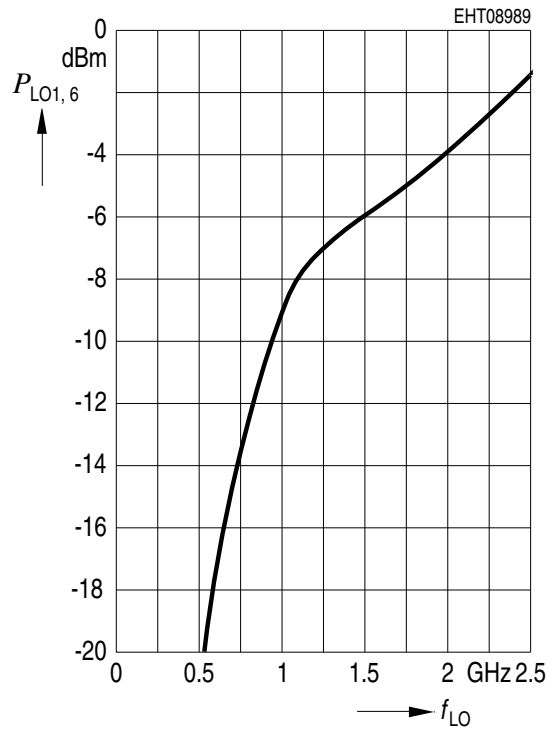

Package Parameters

Dim.	min.	nom.	max.	Gradient	Remark
A	–		1.1	–	–
A ₁	–		0.1	–	–
A ₂	–		1.0	–	–
b	–	0.3	–	–	–
b ₁	–	0.6	–	–	–
c	0.08	–	0.15	–	–
D	2.8	–	3.0	–	–
E	1.2	–	1.4	–	–
lel	–	0.95	–	–	–
le ₁ l	–	1.9	–	–	–
H _E	–	–	2.6	–	–
L _E	–	–	0.6	–	–
a	–	–	–	max. 10°	1)
q	–	–	–	2° ... 30°	–

1) Applicable on all case top sides.

Package Outlines

MW-6
(Special Package)

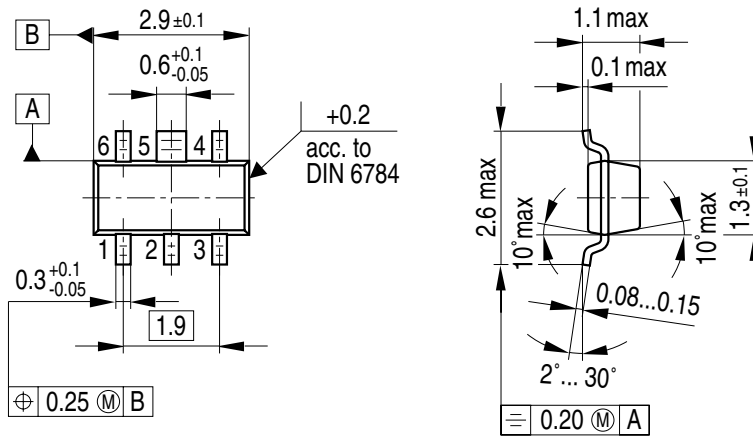

GPW05794

Sorts of Packing

Package outlines for tubes, trays etc. are contained in our Data Book "Package Information".

SMD = Surface Mounted Device

Dimensions in mm

This datasheet has been downloaded from:

www.DatasheetCatalog.com

Datasheets for electronic components.



LittleDiode supplies new, hard to find or obsolete electronic components and semiconductors all over the world.

With over two million different components listed you are sure to find the part you need.

Feel free to visit us today at our online store:

LittleDiode.com

Looking forward to providing you with the best possible service.