

COP884CG/COP888CG 8-Bit Microcontroller with UART and Three Multi-Function Timers

General Description

The COP888 family of microcontrollers uses an 8-bit single chip core architecture fabricated with National Semiconductor's M²CMOS™ process technology. The COP888CG is a member of this expandable 8-bit core processor family of microcontrollers. (Continued)

Key Features

- Full duplex UART
- Three 16-bit timers, each with two 16-bit registers supporting:
 - Processor independent PWM mode
 - External event counter mode
 - Input capture mode
- Quiet design (low radiated emissions)
- 4 kbytes of on-chip ROM
- 192 bytes of on-chip RAM

Additional Peripheral Features

- Idle timer
- Multi-Input Wake Up (MIWU) with optional interrupts (8)
- Two analog comparators
- WATCHDOG™ and Clock Monitor logic
- MICROWIRE/PLUS™ serial I/O

I/O Features

- Memory mapped I/O
- Software selectable I/O options (TRI-STATE® output, push-pull output, weak pull-up input, high impedance input)
- High current outputs

- Schmitt trigger inputs on Port G
- Packages:
 - 44 PLCC with 40 I/O pins
 - 40 DIP with 36 I/O pins
 - 28 DIP with 24 I/O pins
 - 28 SO with 24 I/O pins

CPU/Instruction Set Feature

- 1 μ s instruction cycle time
- Fourteen multi-source vectored interrupts servicing
 - External interrupt with selectable edge
 - Idle timer T0
 - Three timers (each with 2 interrupts)
 - MICROWIRE/PLUS
 - Multi-Input Wake Up
 - Software trap
 - UART (2)
 - Default VIS (default interrupt)
- Versatile and easy to use instruction set
- 8-bit Stack Pointer (SP)—stack in RAM
- Two 8-bit register indirect data memory pointers (B, X)

Fully Static CMOS

- Low current drain (typically < 1 μ A)
- Single supply operation: 2.5V to 6.0V
- Temperature range: -40°C to +85°C

Development Support

- Emulation and OTP devices
- Real time emulation and full program debug offered by MetaLink Development System

Block Diagram

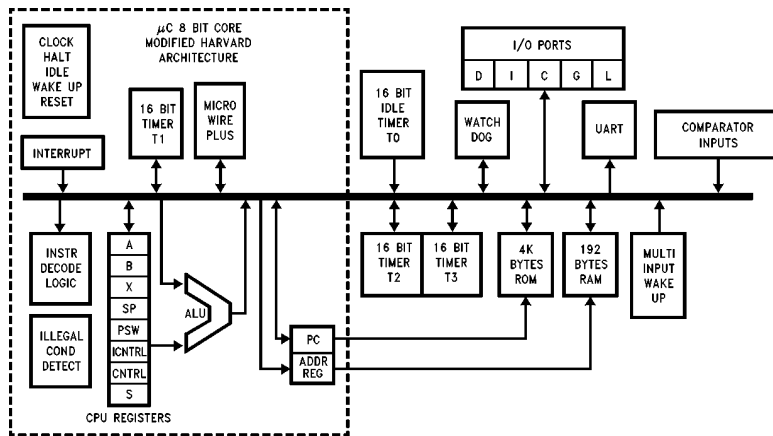

FIGURE 1. Block Diagram

TL/DD/9765-1

TRI-STATE® is a registered trademark of National Semiconductor Corporation. MICROWIRE/PLUS™, M²CMOS™, COP8™ microcontrollers, MICROWIRE™ and WATCHDOG™ are trademarks of National Semiconductor Corporation. iceMASTER™ is a trademark of MetaLink Corporation.

General Description (Continued)

They are fully static parts, fabricated using double-metal silicon gate microCMOS technology. Features include an 8-bit memory mapped architecture, MICROWIRE/PLUS serial I/O, three 16-bit timer/counters supporting three modes (Processor Independent PWM generation, External Event counter, and Input Capture mode capabilities), full duplex UART, two comparators, and two power savings modes (HALT and IDLE), both with a multi-sourced wakeup/interrupt capability. This multi-sourced interrupt capability may

also be used independent of the HALT or IDLE modes. Each I/O pin has software selectable configurations. The device operates over a voltage range of 2.5V to 6V. High throughput is achieved with an efficient, regular instruction set operating at a maximum of 1 μ s per instruction rate.

The device has reduced EMI emissions. Low radiated emissions are achieved by gradual turn-on output drivers and internal I_{CC} filters on the chip logic and crystal oscillator.

Connection Diagrams

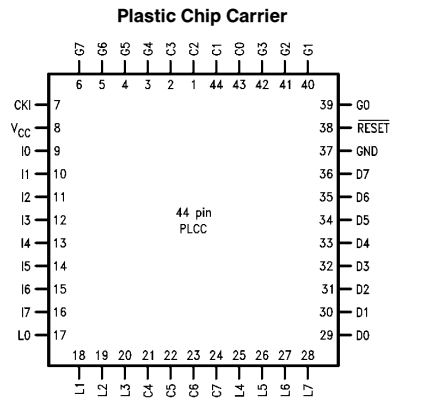

Top View

Order Number COP888CG-XXX/V
See NS Plastic Chip Package Number V44A

Dual-In-Line Package

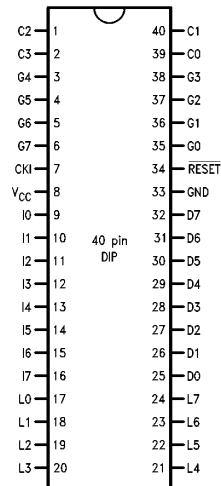

Top View

Order Number COP888CG-XXX/N
See NS Molded Package Number N40A

Dual-In-Line Package

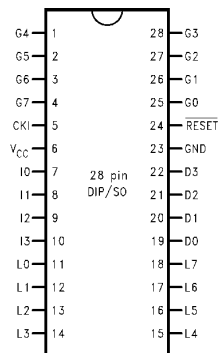

Top View

Order Number COP884CG-XXX/N or COP884CG-XXX/WM
See NS Molded Package Number N28A OR M28B

FIGURE 2a. Connection Diagrams

Connection Diagrams (Continued)

Pinouts for 28-, 40- and 44-Pin Packages

Port	Type	Alt. Fun	Alt. Fun	28-Pin Pack.	40-Pin Pack.	44-Pin Pack.
L0	I/O	MIWU		11	17	17
L1	I/O	MIWU	CKX	12	18	18
L2	I/O	MIWU	TDX	13	19	19
L3	I/O	MIWU	RDX	14	20	20
L4	I/O	MIWU	T2A	15	21	25
L5	I/O	MIWU	T2B	16	22	26
L6	I/O	MIWU	T3A	17	23	27
L7	I/O	MIWU	T3B	18	24	28
G0	I/O	INT		25	35	39
G1	WDOOUT			26	36	40
G2	I/O	T1B		27	37	41
G3	I/O	T1A		28	38	42
G4	I/O	SO		1	3	3
G5	I/O	SK		2	4	4
G6	I	SI		3	5	5
G7	I/CKO	HALT Restart		4	6	6
D0	O			19	25	29
D1	O			20	26	30
D2	O			21	27	31
D3	O			22	28	32
I0	I			7	9	9
I1	I	COMP1IN –		8	10	10
I2	I	COMP1IN +		9	11	11
I3	I	COMP1OUT		10	12	12
I4	I	COMP2IN –			13	13
I5	I	COMP2IN +			14	14
I6	I	COMP2OUT			15	15
I7	I				16	16
D4	O				29	33
D5	O				30	34
D6	O				31	35
D7	O				32	36
C0	I/O				39	43
C1	I/O				40	44
C2	I/O				1	1
C3	I/O				2	2
C4	I/O					21
C5	I/O					22
C6	I/O					23
C7	I/O					24
V _{CC}				6	8	8
GND				23	33	37
CKI				5	7	7
RESET				24	34	38

Absolute Maximum Ratings

If Military/Aerospace specified devices are required, please contact the National Semiconductor Sales Office/Distributors for availability and specifications.

Supply Voltage (V_{CC})	7V
Voltage at Any Pin	-0.3V to $V_{CC} + 0.3V$
Total Current into V_{CC} Pin (Source)	100 mA

Total Current out of GND Pin (Sink)	110 mA
Storage Temperature Range	-65°C to +140°C

Note: Absolute maximum ratings indicate limits beyond which damage to the device may occur. DC and AC electrical specifications are not ensured when operating the device at absolute maximum ratings.

DC Electrical Characteristics -40°C ≤ T_A ≤ +85°C unless otherwise specified

Parameter	Conditions	Min	Typ	Max	Units
Operating Voltage		2.5		6	V
Power Supply Ripple (Note 1)	Peak-to-Peak			0.1 V_{CC}	V
Supply Current (Note 2)					
CKI = 10 MHz	$V_{CC} = 6V, t_c = 1 \mu s$			8.0	mA
CKI = 4 MHz	$V_{CC} = 6V, t_c = 2.5 \mu s$			4.5	mA
CKI = 4 MHz	$V_{CC} = 4.0V, t_c = 2.5 \mu s$			2.5	mA
CKI = 1 MHz	$V_{CC} = 4.0V, t_c = 10 \mu s$			1.4	mA
HALT Current (Note 3)	$V_{CC} = 6V, CKI = 0 MHz$ $V_{CC} = 4.0V, CKI = 0 MHz$		<1 <0.5	10 6	μA μA
IDLE Current					
CKI = 10 MHz	$V_{CC} = 6V, t_c = 1 \mu s$			3.5	mA
CKI = 4 MHz	$V_{CC} = 6V, t_c = 2.5 \mu s$			2.5	mA
CKI = 1 MHz	$V_{CC} = 4.0V, t_c = 10 \mu s$			0.7	mA
Input Levels					
RESET					
Logic High		0.8 V_{CC}			V
Logic Low				0.2 V_{CC}	V
CKI (External and Crystal Osc. Modes)					
Logic High		0.7 V_{CC}			V
Logic Low				0.2 V_{CC}	V
All Other Inputs					
Logic High		0.7 V_{CC}			V
Logic Low				0.2 V_{CC}	V
Hi-Z Input Leakage	$V_{CC} = 6V$	-2		+2	μA
Input Pullup Current	$V_{CC} = 6V, V_{IN} = 0V$	-40		-250	μA
G and L Port Input Hysteresis				0.35 V_{CC}	V
Output Current Levels					
D Outputs					
Source	$V_{CC} = 4V, V_{OH} = 3.3V$ $V_{CC} = 2.5V, V_{OH} = 1.8V$	-0.4 -0.2			mA mA
Sink	$V_{CC} = 4V, V_{OL} = 1V$ $V_{CC} = 2.5V, V_{OL} = 0.4V$	10 2.0			mA mA
All Others					
Source (Weak Pull-Up Mode)	$V_{CC} = 4V, V_{OH} = 2.7V$ $V_{CC} = 2.5V, V_{OH} = 1.8V$	-10 -2.5		-100 -33	μA μA
Source (Push-Pull Mode)	$V_{CC} = 4V, V_{OH} = 3.3V$ $V_{CC} = 2.5V, V_{OH} = 1.8V$	-0.4 -0.2			mA mA
Sink (Push-Pull Mode)	$V_{CC} = 4V, V_{OL} = 0.4V$ $V_{CC} = 2.5V, V_{OL} = 0.4V$	1.6 0.7			mA mA
TRI-STATE Leakage	$V_{CC} = 6.0V$	-2		+2	μA

Note 1: Rate of voltage change must be less than 0.5 V/ms.

Note 2: Supply current is measured after running 2000 cycles with a crystal/resonator oscillator, inputs at rails and outputs open.

Note 3: The HALT mode will stop CKI from oscillating in the RC and the Crystal configurations. Test conditions: All inputs tied to V_{CC} , L, C, and G0-G5 configured as outputs and set high. The D port set to zero. The clock monitor and the comparators are disabled.

DC Electrical Characteristics –40°C ≤ T_A ≤ +85°C unless otherwise specified (Continued)

Parameter	Conditions	Min	Typ	Max	Units
Allowable Sink/Source Current per Pin D Outputs (Sink) All others				15 3	mA mA
Maximum Input Current without Latchup	T _A = 25°C			±100	mA
RAM Retention Voltage, V _r	500 ns Rise and Fall Time (Min)	2			V
Input Capacitance				7	pF
Load Capacitance on D2				1000	pF

AC Electrical Characteristics –40°C ≤ T_A ≤ +85°C unless otherwise specified

Parameter	Conditions	Min	Typ	Max	Units
Instruction Cycle Time (t _c) Crystal, Resonator, R/C Oscillator	4V ≤ V _{CC} ≤ 6V	1		DC	μs
	2.5V ≤ V _{CC} < 4V	2.5		DC	μs
	4V ≤ V _{CC} ≤ 6V	3		DC	μs
	2.5V ≤ V _{CC} < 4V	7.5		DC	μs
Inputs t _{SETUP}	4V ≤ V _{CC} ≤ 6V	200			ns
	2.5V ≤ V _{CC} < 4V	500			ns
t _{HOLD}	4V ≤ V _{CC} ≤ 6V	60			ns
	2.5V ≤ V _{CC} < 4V	150			ns
Output Propagation Delay (Note 4) t _{PD1} , t _{PD0} SO, SK All Others	R _L = 2.2k, C _L = 100 pF				
	4V ≤ V _{CC} ≤ 6V			0.7	μs
	2.5V ≤ V _{CC} < 4V			1.75	μs
	4V ≤ V _{CC} ≤ 6V			1	μs
MICROWIRE™ Setup Time (t _{UWS}) MICROWIRE Hold Time (t _{UWH}) MICROWIRE Output Propagation Delay (t _{UPD})		20			ns
		56			ns
Input Pulse Width Interrupt Input High Time Interrupt Input Low Time Timer Input High Time Timer Input Low Time				220	ns
		1			t _c
		1			t _c
		1			t _c
Reset Pulse Width		1			μs

Note 4: The output propagation delay is referenced to the end of the instruction cycle where the output change occurs.

Comparators AC and DC Characteristics $V_{CC} = 5V, T_A = 25^\circ C$

Parameter	Conditions	Min	Typ	Max	Units
Input Offset Voltage	$0.4V \leq V_{IN} \leq V_{CC} - 1.5V$		± 10	± 25	mV
Input Common Mode Voltage Range		0.4		$V_{CC} - 1.5$	V
Low Level Output Current	$V_{OL} = 0.4V$	1.6			mA
High Level Output Current	$V_{OH} = 4.6V$	1.6			mA
DC Supply Current Per Comparator (When Enabled)				250	μA
Response Time	TBD mV Step, TBD mV Overdrive, 100 pF Load		1		μs

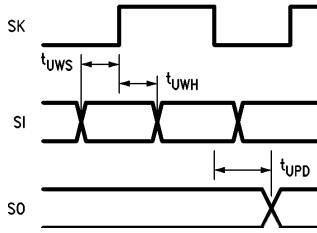

FIGURE 2. MICROWIRE/PLUS Timing
TL/DD/9765-7

Pin Descriptions

V_{CC} and GND are the power supply pins.

CKI is the clock input. This can come from an R/C generated oscillator, or a crystal oscillator (in conjunction with CKO). See Oscillator Description section.

RESET is the master reset input. See Reset Description section.

The device contains three bidirectional 8-bit I/O ports (C, G and L), where each individual bit may be independently configured as an input (Schmitt trigger inputs on ports L and G), output or TRI-STATE under program control. Three data memory address locations are allocated for each of these I/O ports. Each I/O port has two associated 8-bit memory mapped registers, the CONFIGURATION register and the output DATA register. A memory mapped address is also reserved for the input pins of each I/O port. (See the memory map for the various addresses associated with the I/O ports.) Figure 3 shows the I/O port configurations. The DATA and CONFIGURATION registers allow for each port bit to be individually configured under software control as shown below:

CONFIGURATION Register	DATA Register	Port Set-Up
0	0	Hi-Z Input (TRI-STATE Output)
0	1	Input with Weak Pull-Up
1	0	Push-Pull Zero Output
1	1	Push-Pull One Output

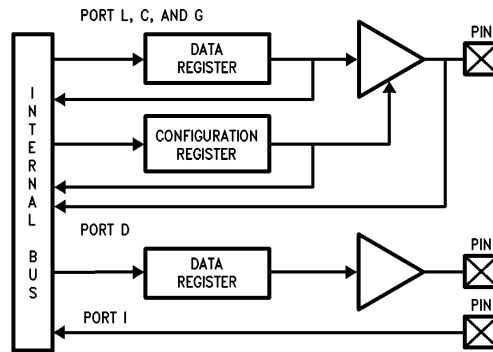

FIGURE 3. I/O Port Configurations
TL/DD/9765-8

PORT L is an 8-bit I/O port. All L-pins have Schmitt triggers on the inputs.

The Port L supports Multi-Input Wake Up on all eight pins. L1 is used for the UART external clock. L2 and L3 are used for the UART transmit and receive. L4 and L5 are used for the timer input functions T2A and T2B. L6 and L7 are used for the timer input functions T3A and T3B.

The Port L has the following alternate features:

- L0 MIWU
- L1 MIWU or CKX
- L2 MIWU or TDX
- L3 MIWU or RDX
- L4 MIWU or T2A
- L5 MIWU or T2B
- L6 MIWU or T3A
- L7 MIWU or T3B

Port G is an 8-bit port with 5 I/O pins (G0, G2-G5), an input pin (G6), and two dedicated output pins (G1 and G7). Pins G0 and G2-G6 all have Schmitt Triggers on their inputs. Pin G1 serves as the dedicated WDOUT WATCHDOG output, while pin G7 is either input or output depending on the oscillator mask option selected. With the crystal oscillator option selected, G7 serves as the dedicated output pin for the CKO clock output. With the single-pin R/C oscillator mask option selected, G7 serves as a general purpose input pin but is also used to bring the device out of HALT mode with a low to high transition on G7. There are two registers associated with the G Port, a data register and a configuration register. Therefore, each of the 5 I/O bits (G0, G2-G5) can be individually configured under software control.

Pin Descriptions (Continued)

Since G6 is an input only pin and G7 is the dedicated CKO clock output pin (crystal clock option) or general purpose input (R/C clock option), the associated bits in the data and configuration registers for G6 and G7 are used for special purpose functions as outlined below. Reading the G6 and G7 data bits will return zeros.

Note that the chip will be placed in the HALT mode by writing a "1" to bit 7 of the Port G Data Register. Similarly the chip will be placed in the IDLE mode by writing a "1" to bit 6 of the Port G Data Register.

Writing a "1" to bit 6 of the Port G Configuration Register enables the MICROWIRE/PLUS to operate with the alternate phase of the SK clock. The G7 configuration bit, if set high, enables the clock start up delay after HALT when the R/C clock configuration is used.

	Config Reg.	Data Reg.
G7	CLKDLY	HALT
G6	Alternate SK	IDLE

Port G has the following alternate features:

- G0 INTR (External Interrupt Input)
- G2 T1B (Timer T1 Capture Input)
- G3 T1A (Timer T1 I/O)
- G4 SO (MICROWIRE™ Serial Data Output)
- G5 SK (MICROWIRE Serial Clock)
- G6 SI (MICROWIRE Serial Data Input)

Port G has the following dedicated functions:

- G1 WDOOUT WATCHDOG and/or Clock Monitor dedicated output
- G7 CKO Oscillator dedicated output or general purpose input

Port C is an 8-bit I/O port. The 40-pin device does not have a full complement of Port C pins. The unavailable pins are not terminated. A read operation for these unterminated pins will return unpredictable values.

PORT I is an eight-bit Hi-Z input port. The 28-pin device does not have a full complement of Port I pins. The unavailable pins are not terminated i.e., they are floating. A read operation for these unterminated pins will return unpredictable values. The user must ensure that the software takes this into account by either masking or restricting the accesses to bit operations. The unterminated Port I pins will draw power only when addressed.

Port I1–I3 are used for Comparator 1. Port I4–I6 are used for Comparator 2.

The Port I has the following alternate features.

- I1 COMP1–IN (Comparator 1 Negative Input)
- I2 COMP1+IN (Comparator 1 Positive Input)
- I3 COMP1OUT (Comparator 1 Output)
- I4 COMP2–IN (Comparator 2 Negative Input)
- I5 COMP2+IN (Comparator 2 Positive Input)
- I6 COMP2OUT (Comparator 2 Output)

Port D is an 8-bit output port that is preset high when **RESET** goes low. The user can tie two or more D port outputs together in order to get a higher drive.

Functional Description

The architecture of the device is modified Harvard architecture. With the Harvard architecture, the control store program memory (ROM) is separated from the data store memory (RAM). Both ROM and RAM have their own separate addressing space with separate address buses. The architecture, though based on Harvard architecture, permits transfer of data from ROM to RAM.

CPU REGISTERS

The CPU can do an 8-bit addition, subtraction, logical or shift operation in one instruction (t_c) cycle time.

There are six CPU registers:

A is the 8-bit Accumulator Register

PC is the 15-bit Program Counter Register

PU is the upper 7 bits of the program counter (PC)

PL is the lower 8 bits of the program counter (PC)

B is an 8-bit RAM address pointer, which can be optionally post auto incremented or decremented.

X is an 8-bit alternate RAM address pointer, which can be optionally post auto incremented or decremented.

SP is the 8-bit stack pointer, which points to the subroutine/interrupt stack (in RAM). The SP is initialized to RAM address 06F with reset.

S is the 8-bit Data Segment Address Register used to extend the lower half of the address range (00 to 7F) into 256 data segments of 128 bytes each.

All the CPU registers are memory mapped with the exception of the Accumulator (A) and the Program Counter (PC).

PROGRAM MEMORY

The program memory consists of 4096 bytes of ROM. These bytes may hold program instructions or constant data (data tables for the LAID instruction, jump vectors for the JID instruction, and interrupt vectors for the VIS instruction). The program memory is addressed by the 15-bit program counter (PC). All interrupts in the devices vector to program memory location 0FF Hex.

DATA MEMORY

The data memory address space includes the on-chip RAM and data registers, the I/O registers (Configuration, Data and Pin), the control registers, the MICROWIRE/PLUS SIO shift register, and the various registers, and counters associated with the timers (with the exception of the IDLE timer). Data memory is addressed directly by the instruction or indirectly by the B, X, SP pointers and S register.

The device has 192 bytes of RAM. Sixteen bytes of RAM are mapped as "registers" at addresses 0F0 to 0FF Hex. These registers can be loaded immediately, and also decremented and tested with the DRSZ (decrement register and skip if zero) instruction. The memory pointer registers X, SP, B and S are memory mapped into this space at address locations 0FC to 0FF Hex respectively, with the other registers being available for general usage.

The instruction set permits any bit in memory to be set, reset or tested. All I/O and registers (except A and PC) are memory mapped; therefore, I/O bits and register bits can be directly and individually set, reset and tested. The accumulator (A) bits can also be directly and individually tested.

Note: RAM contents are undefined upon power-up.

Data Memory Segment RAM Extension

Data memory address 0FF is used as a memory mapped location for the Data Segment Address Register (S).

The data store memory is either addressed directly by a single byte address within the instruction, or indirectly relative to the reference of the B, X, or SP pointers (each contains a single-byte address). This single-byte address allows an addressing range of 256 locations from 00 to FF hex. The upper bit of this single-byte address divides the data store memory into two separate sections as outlined previously. With the exception of the RAM register memory from address locations 00F0 to 00FF, all RAM memory is memory mapped with the upper bit of the single-byte address being equal to zero. This allows the upper bit of the single-byte address to determine whether or not the base address range (from 0000 to 00FF) is extended. If this upper bit equals one (representing address range 0080 to 00FF), then address extension does not take place. Alternatively, if this upper bit equals zero, then the data segment extension register S is used to extend the base address range (from 0000 to 007F) from XX00 to XX7F, where XX represents the 8 bits from the S register. Thus the 128-byte data segment extensions are located from addresses 0100 to 017F for data segment 1, 0200 to 027F for data segment 2, etc., up to FF00 to FF7F for data segment 255. The base address range from 0000 to 007F represents data segment 0.

Figure 4 illustrates how the S register data memory extension is used in extending the lower half of the base address range (00 to 7F hex) into 256 data segments of 128 bytes each, with a total addressing range of 32 kbytes from XX00 to XX7F. This organization allows a total of 256 data segments of 128 bytes each with an additional upper base segment of 128 bytes. Furthermore, all addressing modes are available for all data segments. The S register must be changed under program control to move from one data segment (128 bytes) to another. However, the upper base segment (containing the 16 memory registers, I/O registers, control registers, etc.) is always available regardless of the contents of the S register, since the upper base segment (address range 0080 to 00FF) is independent of data segment extension.

The instructions that utilize the stack pointer (SP) always reference the stack as part of the base segment (Segment 0), regardless of the contents of the S register. The S register is not changed by these instructions. Consequently, the stack (used with subroutine linkage and interrupts) is always located in the base segment. The stack pointer will be initialized to point at data memory location 006F as a result of reset.

The 128 bytes of RAM contained in the base segment are split between the lower and upper base segments. The first 116 bytes of RAM are resident from address 0000 to 006F in the lower base segment, while the remaining 16 bytes of RAM represent the 16 data memory registers located at addresses 00F0 to 00FF of the upper base segment. No RAM is located at the upper sixteen addresses (0070 to 007F) of the lower base segment.

Additional RAM beyond these initial 128 bytes, however, will always be memory mapped in groups of 128 bytes (or less) at the data segment address extensions (XX00 to XX7F) of the lower base segment. The additional 64 bytes of RAM

(beyond the initial 128 bytes) are memory mapped at address locations 0100 to 013F hex.

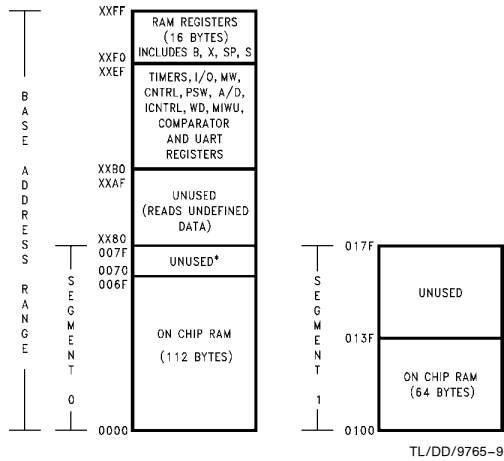

*Reads as all ones.

FIGURE 4. RAM Organization

Reset

The RESET input when pulled low initializes the microcontroller. Initialization will occur whenever the RESET input is pulled low. Upon initialization, the data and configuration registers for ports L, G and C are cleared, resulting in these Ports being initialized to the TRI-STATE mode. Pin G1 of the G Port is an exception (as noted below) since pin G1 is dedicated as the WATCHDOG and/or Clock Monitor error output pin. Port D is set high. The PC, PSW, ICNTRL, CNTRL, T2CNTRL and T3CNTRL control registers are cleared. The UART registers PSR, ENU (except that TBMT bit is set), ENUR and ENUI are cleared. The Comparator Select Register is cleared. The S register is initialized to zero. The Multi-Input Wakeup registers WKEN, WKEDG and WKPND are cleared. The stack pointer, SP, is initialized to 6F Hex.

The device comes out of reset with both the WATCHDOG logic and the Clock Monitor detector armed, with the WATCHDOG service window bits set and the Clock Monitor bit set. The WATCHDOG and Clock Monitor circuits are inhibited during reset. The WATCHDOG service window bits being initialized high default to the maximum WATCHDOG service window of 64k t_C clock cycles. The Clock Monitor bit being initialized high will cause a Clock Monitor error following reset if the clock has not reached the minimum specified frequency at the termination of reset. A Clock Monitor error will cause an active low error output on pin G1. This error output will continue until 16 t_C –32 t_C clock cycles following the clock frequency reaching the minimum specified value, at which time the G1 output will enter the TRI-STATE mode.

The external RC network shown in Figure 5 should be used to ensure that the RESET pin is held low until the power supply to the chip stabilizes.

Reset (Continued)

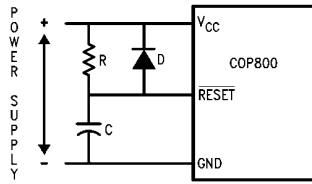

TL/DD/9765-10

$RC > 5 \times$ Power Supply Rise Time

FIGURE 5. Recommended Reset Circuit

Oscillator Circuits

The chip can be driven by a clock input on the CKI input pin which can be between DC and 10 MHz. The CKO output clock is on pin G7 (crystal configuration). The CKI input frequency is divided down by 10 to produce the instruction cycle clock ($1/t_c$).

Figure 6 shows the Crystal and R/C diagrams.

CRYSTAL OSCILLATOR

CKI and CKO can be connected to make a closed loop crystal (or resonator) controlled oscillator.

Table A shows the component values required for various standard crystal values.

R/C OSCILLATOR

By selecting CKI as a single pin oscillator input, a single pin R/C oscillator circuit can be connected to it. CKO is available as a general purpose input, and/or HALT restart input.

Table B shows the variation in the oscillator frequencies as functions of the component (R and C) values.

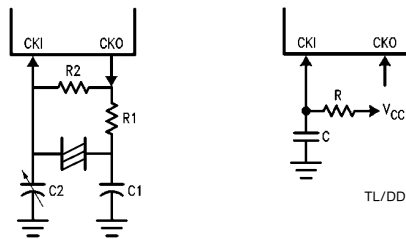

TL/DD/9765-12

TL/DD/9765-11

FIGURE 6. Crystal and R/C Oscillator Diagrams

TABLE A. Crystal Oscillator Configuration, $T_A = 25^\circ\text{C}$

R1 (k Ω)	R2 (M Ω)	C1 (pF)	C2 (pF)	CKI Freq (MHz)	Conditions
0	1	30	30-36	10	$V_{CC} = 5V$
0	1	30	30-36	4	$V_{CC} = 5.0V$
0	1	200	100-150	0.455	$V_{CC} = 5V$

TABLE B. RC Oscillator Configuration, $T_A = 25^\circ\text{C}$

R (k Ω)	C (pF)	CKI Freq (MHz)	Instr. Cycle (μs)	Conditions
3.3	82	2.2 to 2.7	3.7 to 4.6	$V_{CC} = 5V$
5.6	100	1.1 to 1.3	7.4 to 9.0	$V_{CC} = 5V$
6.8	100	0.9 to 1.1	8.8 to 10.8	$V_{CC} = 5V$

Note: $3k \leq R \leq 200k$

$50 \text{ pF} \leq C \leq 200 \text{ pF}$

Control Registers

CNTRL Register (Address X'00EE)

The Timer1 (T1) and MICROWIRE/PLUS control register contains the following bits:

- SL1 & SL0 Select the MICROWIRE/PLUS clock divide by (00 = 2, 01 = 4, 1x = 8)
- IEDG External interrupt edge polarity select (0 = Rising edge, 1 = Falling edge)
- MSEL Selects G5 and G4 as MICROWIRE/PLUS signals SK and SO respectively
- T1C0 Timer T1 Start/Stop control in timer modes 1 and 2
Timer T1 Underflow Interrupt Pending Flag in timer mode 3
- T1C1 Timer T1 mode control bit
- T1C2 Timer T1 mode control bit
- T1C3 Timer T1 mode control bit

T1C3	T1C2	T1C1	T1C0	MSEL	IEDG	SL1	SL0
------	------	------	------	------	------	-----	-----

Bit 7

Bit 0

Control Registers (Continued)

PSW Register (Address X'00EF)

The PSW register contains the following select bits:

GIE	Global interrupt enable (enables interrupts)
EXEN	Enable external interrupt
BUSY	MICROWIRE/PLUS busy shifting flag
EXPND	External interrupt pending
T1ENA	Timer T1 Interrupt Enable for Timer Underflow or T1A Input capture edge
T1PNDA	Timer T1 Interrupt Pending Flag (Autoreload RA in mode 1, T1 Underflow in Mode 2, T1A capture edge in mode 3)
C	Carry Flag
HC	Half Carry Flag

HC	C	T1PNDA	T1ENA	EXPND	BUSY	EXEN	GIE
----	---	--------	-------	-------	------	------	-----

Bit 7 Bit 0

The Half-Carry bit is also affected by all the instructions that affect the Carry flag. The SC (Set Carry) and RC (Reset Carry) instructions will respectively set or clear both the carry flags. In addition to the SC and RC instructions, ADC, SUBC, RRC and RLC instructions affect the carry and Half Carry flags.

ICNTRL Register (Address X'00E8)

The ICNTRL register contains the following bits:

T1ENB	Timer T1 Interrupt Enable for T1B Input capture edge
T1PNDB	Timer T1 Interrupt Pending Flag for T1B capture edge
μ WEN	Enable MICROWIRE/PLUS interrupt
μ WPND	MICROWIRE/PLUS interrupt pending
T0EN	Timer T0 Interrupt Enable (Bit 12 toggle)
T0PND	Timer T0 Interrupt pending
LPEN	L Port Interrupt Enable (Multi-Input Wakeup/Interrupt)
Bit 7 could be used as a flag	

Unused	LPEN	T0PND	T0EN	μ WPND	μ WEN	T1PNDB	T1ENB
--------	------	-------	------	------------	-----------	--------	-------

Bit 7 Bit 0

T2CNTRL Register (Address X'00C6)

The T2CNTRL register contains the following bits:

T2ENB	Timer T2 Interrupt Enable for T2B Input capture edge
T2PNDB	Timer T2 Interrupt Pending Flag for T2B capture edge
T2ENA	Timer T2 Interrupt Enable for Timer Underflow or T2A Input capture edge
T2PNDA	Timer T2 Interrupt Pending Flag (Autoreload RA in mode 1, T2 Underflow in mode 2, T2A capture edge in mode 3)
T2C0	Timer T2 Start/Stop control in timer modes 1 and 2 Timer T2 Underflow Interrupt Pending Flag in timer mode 3

T2C1	Timer T2 mode control bit
T2C2	Timer T2 mode control bit
T2C3	Timer T2 mode control bit

T2C3	T2C2	T2C1	T2C0	T2PNDA	T2ENA	T2PNDB	T2ENB
------	------	------	------	--------	-------	--------	-------

Bit 7

Bit 0

T3CNTRL Register (Address X'00B6)

The T3CNTRL register contains the following bits:

T3ENB	Timer T3 Interrupt Enable for T3B
T3PNDB	Timer T3 Interrupt Pending Flag for T3B pin (T3B capture edge)
T3ENA	Timer T3 Interrupt Enable for Timer Underflow or T3A pin
T3PNDA	Timer T3 Interrupt Pending Flag (Autoload RA in mode 1, T3 Underflow in mode 2, T3a capture edge in mode 3)
T3C0	Timer T3 Start/Stop control in timer modes 1 and 2 Timer T3 Underflow Interrupt Pending Flag in timer mode 3
T3C1	Timer T3 mode control bit
T3C2	Timer T3 mode control bit
T3C3	Timer T3 mode control bit

T3C3	T3C2	T3C1	T3C0	T3PNDA	T3ENA	T3PNDB	T3ENB
------	------	------	------	--------	-------	--------	-------

Bit 7

Bit 0

Timers

The device contains a very versatile set of timers (T0, T1, T2, T3). All timers and associated autoreload/capture registers power up containing random data.

TIMER T0 (IDLE TIMER)

The device supports applications that require maintaining real time and low power with the IDLE mode. This IDLE mode support is furnished by the IDLE timer T0, which is a 16-bit timer. The Timer T0 runs continuously at the fixed rate of the instruction cycle clock, t_c . The user cannot read or write to the IDLE Timer T0, which is a count down timer. The Timer T0 supports the following functions:

Exit out of the Idle Mode (See Idle Mode description)
WATCHDOG logic (See WATCHDOG description)
Start up delay out of the HALT mode

The IDLE Timer T0 can generate an interrupt when the thirteenth bit toggles. This toggle is latched into the T0PND pending flag, and will occur every 4 ms at the maximum clock frequency ($t_c = 1 \mu s$). A control flag T0EN allows the interrupt from the thirteenth bit of Timer T0 to be enabled or disabled. Setting T0EN will enable the interrupt, while resetting it will disable the interrupt.

Timers (Continued)

TIMER T1, TIMER T2 AND TIMER T3

The device has a set of three powerful timer/counter blocks, T1, T2 and T3. The associated features and functioning of a timer block are described by referring to the timer block Tx. Since the three timer blocks, T1, T2 and T3 are identical, all comments are equally applicable to any of the three timer blocks.

Each timer block consists of a 16-bit timer, Tx, and two supporting 16-bit autoreload/capture registers, RxA and RxB. Each timer block has two pins associated with it, TxA and TxB. The pin TxA supports I/O required by the timer block, while the pin TxB is an input to the timer block. The powerful and flexible timer block allows the device to easily perform all timer functions with minimal software overhead. The timer block has three operating modes: Processor Independent PWM mode, External Event Counter mode, and Input Capture mode.

The control bits TxC3, TxC2, and TxC1 allow selection of the different modes of operation.

Mode 1. Processor Independent PWM Mode

As the name suggests, this mode allows the device to generate a PWM signal with very minimal user intervention. The user only has to define the parameters of the PWM signal (ON time and OFF time). Once begun, the timer block will continuously generate the PWM signal completely independent of the microcontroller. The user software services the timer block only when the PWM parameters require updating.

In this mode the timer Tx counts down at a fixed rate of t_c . Upon every underflow the timer is alternately reloaded with the contents of supporting registers, RxA and RxB. The very first underflow of the timer causes the timer to reload from the register RxA. Subsequent underflows cause the timer to be reloaded from the registers alternately beginning with the register RxB.

The Tx Timer control bits, TxC3, TxC2 and TxC1 set up the timer for PWM mode operation.

Figure 7 shows a block diagram of the timer in PWM mode. The underflows can be programmed to toggle the TxA output pin. The underflows can also be programmed to generate interrupts.

Underflows from the timer are alternately latched into two pending flags, TxPNDA and TxPNDB. The user must reset these pending flags under software control. Two control enable flags, TxENA and TxENB, allow the interrupts from the timer underflow to be enabled or disabled. Setting the timer enable flag TxENA will cause an interrupt when a timer underflow causes the RxA register to be reloaded into the timer. Setting the timer enable flag TxENB will cause an interrupt when a timer underflow causes the RxB register to be reloaded into the timer. Resetting the timer enable flags will disable the associated interrupts.

Either or both of the timer underflow interrupts may be enabled. This gives the user the flexibility of interrupting once per PWM period on either the rising or falling edge of the PWM output. Alternatively, the user may choose to interrupt on both edges of the PWM output.

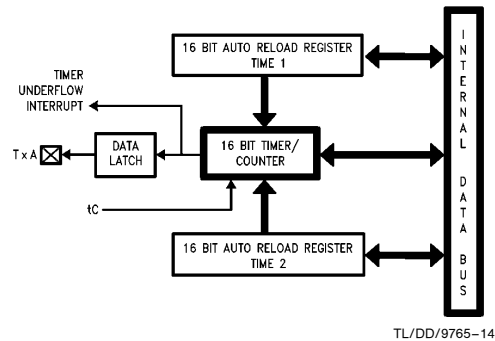

TL/DD/9765-14

FIGURE 7. Timer in PWM Mode

Mode 2. External Event Counter Mode

This mode is quite similar to the processor independent PWM mode described above. The main difference is that the timer, Tx, is clocked by the input signal from the TxA pin. The Tx timer control bits, TxC3, TxC2 and TxC1 allow the timer to be clocked either on a positive or negative edge from the TxA pin. Underflows from the timer are latched into the TxPNDA pending flag. Setting the TxENA control flag will cause an interrupt when the timer underflows.

In this mode the input pin TxB can be used as an independent positive edge sensitive interrupt input if the TxENB control flag is set. The occurrence of a positive edge on the TxB input pin is latched into the TxPNDB flag.

Figure 8 shows a block diagram of the timer in External Event Counter mode.

Note: The PWM output is not available in this mode since the TxA pin is being used as the counter input clock.

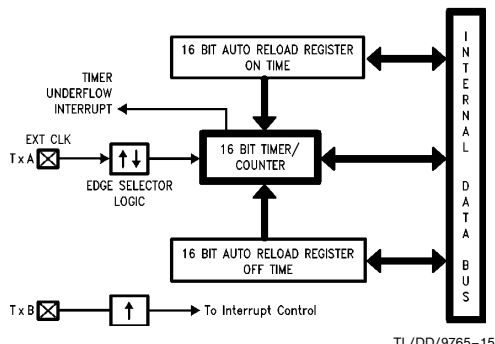

TL/DD/9765-15

FIGURE 8. Timer in External Event Counter Mode

Mode 3. Input Capture Mode

The device can precisely measure external frequencies or time external events by placing the timer block, Tx, in the input capture mode.

In this mode, the timer Tx is constantly running at the fixed t_c rate. The two registers, RxA and RxB, act as capture registers. Each register acts in conjunction with a pin. The register RxA acts in conjunction with the TxA pin and the register RxB acts in conjunction with the TxB pin.

Timers (Continued)

The timer value gets copied over into the register when a trigger event occurs on its corresponding pin. Control bits, TxC3, TxC2 and TxC1, allow the trigger events to be specified either as a positive or a negative edge. The trigger condition for each input pin can be specified independently.

The trigger conditions can also be programmed to generate interrupts. The occurrence of the specified trigger condition on the TxA and TxB pins will be respectively latched into the pending flags, TxPNDA and TxPNDB. The control flag TxENA allows the interrupt on TxA to be either enabled or disabled. Setting the TxENA flag enables interrupts to be generated when the selected trigger condition occurs on the TxA pin. Similarly, the flag TxENB controls the interrupts from the TxB pin.

Underflows from the timer can also be programmed to generate interrupts. Underflows are latched into the timer TxCO pending flag (the TxCO control bit serves as the timer underflow interrupt pending flag in the Input Capture mode). Consequently, the TxCO control bit should be reset when entering the Input Capture mode. The timer underflow interrupt is enabled with the TxENA control flag. When a TxA interrupt occurs in the Input Capture mode, the user must check both the TxPNDA and TxCO pending flags in order to determine whether a TxA input capture or a timer underflow (or both) caused the interrupt.

Figure 9 shows a block diagram of the timer in Input Capture mode.

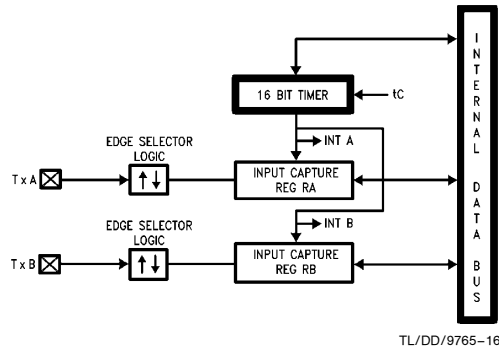

FIGURE 9. Timer in Input Capture Mode

TIMER CONTROL FLAGS

The timers T1, T2 and T3 have identical control structures. The control bits and their functions are summarized below.

TxC0	Timer Start/Stop control in Modes 1 and 2 (Processor Independent PWM and External Event Counter), where 1 = Start, 0 = Stop Timer Underflow Interrupt Pending Flag in Mode 3 (Input Capture)
TxPNDA	Timer Interrupt Pending Flag
TxPNDB	Timer Interrupt Pending Flag
TxENA	Timer Interrupt Enable Flag 1 = Timer Interrupt Enabled 0 = Timer Interrupt Disabled
TxENB	Timer Interrupt Enable Flag 1 = Timer Interrupt Enabled 0 = Timer Interrupt Disabled
TxC3	Timer mode control
TxC2	Timer mode control
TxC1	Timer mode control

Timers (Continued)

The timer mode control bits (TxC3, TxC2 and TxC1) are detailed below:

TxC3	TxC2	TxC1	Timer Mode	Interrupt A Source	Interrupt B Source	Timer Counts On
0	0	0	MODE 2 (External Event Counter)	Timer Underflow	Pos. TxB Edge	TxA Pos. Edge
0	0	1	MODE 2 (External Event Counter)	Timer Underflow	Pos. TxB Edge	TxA Neg. Edge
1	0	1	MODE 1 (PWM) TxA Toggle	Autoreload RA	Autoreload RB	t_c
1	0	0	MODE 1 (PWM) No TxA Toggle	Autoreload RA	Autoreload RB	t_c
0	1	0	MODE 3 (Capture) Captures: TxA Pos. Edge TxB Pos. Edge	Pos. TxA Edge or Timer Underflow	Pos. TxB Edge	t_c
1	1	0	MODE 3 (Capture) Captures: TxA Pos. Edge TxB Neg. Edge	Pos. TxA Edge or Timer Underflow	Neg. TxB Edge	t_c
0	1	1	MODE 3 (Capture) Captures: TxA Neg. Edge TxB Pos. Edge	Neg. TxB Edge or Timer Underflow	Pos. TxB Edge	t_c
1	1	1	MODE 3 (Capture) Captures: TxA Neg. Edge TxB Neg. Edge	Neg. TxA Edge or Timer Underflow	Neg. TxB Edge	t_c

Power Save Modes

The device offers the user two power save modes of operation: HALT and IDLE. In the HALT mode, all microcontroller activities are stopped. In the IDLE mode, the on-board oscillator circuitry the WATCHDOG logic, the Clock Monitor and timer T0 are active but all other microcontroller activities are stopped. In either mode, all on-board RAM, registers, I/O states, and timers (with the exception of T0) are unaltered.

HALT MODE

The device can be placed in the HALT mode by writing a "1" to the HALT flag (G7 data bit). All microcontroller activities, including the clock and timers, are stopped. The WATCHDOG logic is disabled during the HALT mode. However, the clock monitor circuitry if enabled remains active and will cause the WATCHDOG output pin (WDOUT) to go low. If the HALT mode is used and the user does not want to activate the WDOUT pin, the Clock Monitor should be disabled after the device comes out of reset (resetting the Clock Monitor control bit with the first write to the WDSVR register). In the HALT mode, the power requirements of the device are minimal and the applied voltage (V_{CC}) may be decreased to V_r ($V_r = 2.0V$) without altering the state of the machine.

The device supports three different ways of exiting the HALT mode. The first method of exiting the HALT mode is with the Multi-Input Wakeup feature on the L port. The second method is with a low to high transition on the CKO (G7) pin. This method precludes the use of the crystal clock con-

figuration (since CKO becomes a dedicated output), and so may be used with an RC clock configuration. The third method of exiting the HALT mode is by pulling the \overline{RESET} pin low.

Since a crystal or ceramic resonator may be selected as the oscillator, the Wakeup signal is not allowed to start the chip running immediately since crystal oscillators and ceramic resonators have a delayed start up time to reach full amplitude and frequency stability. The IDLE timer is used to generate a fixed delay to ensure that the oscillator has indeed stabilized before allowing instruction execution. In this case, upon detecting a valid Wakeup signal, only the oscillator circuitry is enabled. The IDLE timer is loaded with a value of 256 and is clocked with the t_c instruction cycle clock. The t_c clock is derived by dividing the oscillator clock down by a factor of 10. The Schmitt trigger following the CKI inverter on the chip ensures that the IDLE timer is clocked only when the oscillator has a sufficiently large amplitude to meet the Schmitt trigger specifications. This Schmitt trigger is not part of the oscillator closed loop. The startup timeout from the IDLE timer enables the clock signals to be routed to the rest of the chip.

If an RC clock option is being used, the fixed delay is introduced optionally. A control bit, CLKDLY, mapped as configuration bit G7, controls whether the delay is to be introduced or not. The delay is included if CLKDLY is set, and excluded if CLKDLY is reset. The CLKDLY bit is cleared on reset.

Power Save Modes (Continued)

The device has two mask options associated with the HALT mode. The first mask option enables the HALT mode feature, while the second mask option disables the HALT mode. With the HALT mode enable mask option, the device will enter and exit the HALT mode as described above. With the HALT disable mask option, the device cannot be placed in the HALT mode (writing a "1" to the HALT flag will have no effect).

The WATCHDOG detector circuit is inhibited during the HALT mode. However, the clock monitor circuit if enabled remains active during HALT mode in order to ensure a clock monitor error if the device inadvertently enters the HALT mode as a result of a runaway program or power glitch.

IDLE MODE

The device is placed in the IDLE mode by writing a "1" to the IDLE flag (G6 data bit). In this mode, all activities, except the associated on-board oscillator circuitry, the WATCHDOG logic, the clock monitor and the IDLE Timer T0, are stopped.

As with the HALT mode, the device can be returned to normal operation with a reset, or with a Multi-Input Wakeup from the L Port. Alternately, the microcontroller resumes normal operation from the IDLE mode when the thirteenth bit (representing 4.096 ms at internal clock frequency of 1 MHz, $t_c = 1 \mu s$) of the IDLE Timer toggles.

This toggle condition of the thirteenth bit of the IDLE Timer T0 is latched into the TOPND pending flag.

The user has the option of being interrupted with a transition on the thirteenth bit of the IDLE Timer T0. The interrupt can be enabled or disabled via the T0EN control bit. Setting the T0EN flag enables the interrupt and vice versa.

The user can enter the IDLE mode with the Timer T0 interrupt enabled. In this case, when the TOPND bit gets set, the device will first execute the Timer T0 interrupt service routine and then return to the instruction following the "Enter Idle Mode" instruction.

Alternatively, the user can enter the IDLE mode with the IDLE Timer T0 interrupt disabled. In this case, the device will resume normal operation with the instruction immediately following the "Enter IDLE Mode" instruction.

Note: It is necessary to program two NOP instructions following both the set HALT mode and set IDLE mode instructions. These NOP instructions are necessary to allow clock resynchronization following the HALT or IDLE modes.

Multi-Input Wakeup

The Multi-Input Wakeup feature is used to return (wakeup) the device from either the HALT or IDLE modes. Alternately Multi-Input Wakeup/Interrupt feature may also be used to generate up to 8 edge selectable external interrupts.

Figure 10 shows the Multi-Input Wakeup logic.

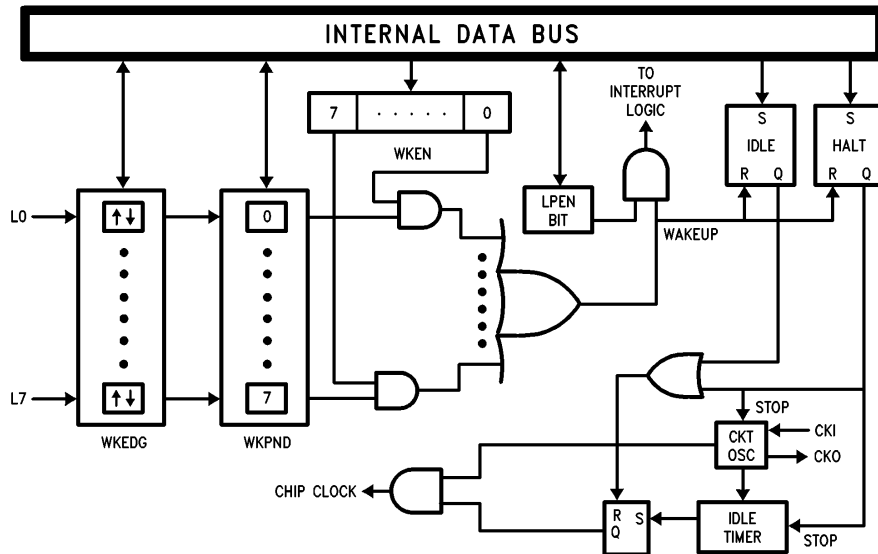

FIGURE 10. Multi-Input Wake Up Logic

TL/DD/9765-17

Multi-Input Wakeup (Continued)

The Multi-Input Wakeup feature utilizes the L Port. The user selects which particular L port bit (or combination of L Port bits) will cause the device to exit the HALT or IDLE modes. The selection is done through the Reg: WKEN. The Reg: WKEN is an 8-bit read/write register, which contains a control bit for every L port bit. Setting a particular WKEN bit enables a Wakeup from the associated L port pin.

The user can select whether the trigger condition on the selected L Port pin is going to be either a positive edge (low to high transition) or a negative edge (high to low transition). This selection is made via the Reg: WKEDG, which is an 8-bit control register with a bit assigned to each L Port pin. Setting the control bit will select the trigger condition to be a negative edge on that particular L Port pin. Resetting the bit selects the trigger condition to be a positive edge. Changing an edge select entails several steps in order to avoid a pseudo Wakeup condition as a result of the edge change. First, the associated WKEN bit should be reset, followed by the edge select change in WKEDG. Next, the associated WKPND bit should be cleared, followed by the associated WKEN bit being re-enabled.

An example may serve to clarify this procedure. Suppose we wish to change the edge select from positive (low going high) to negative (high going low) for L Port bit 5, where bit 5 has previously been enabled for an input interrupt. The program would be as follows:

```
RBIT 5, WKEN
SBIT 5, WKEDG
RBIT 5, WKPND
SBIT 5, WKEN
```

If the L port bits have been used as outputs and then changed to inputs with Multi-Input Wakeup/Interrupt, a safety procedure should also be followed to avoid inherited pseudo wakeup conditions. After the selected L port bits have been changed from output to input but before the associated WKEN bits are enabled, the associated edge select bits in WKEDG should be set or reset for the desired edge selects, followed by the associated WKPND bits being cleared.

This same procedure should be used following reset, since the L port inputs are left floating as a result of reset.

The occurrence of the selected trigger condition for Multi-Input Wakeup is latched into a pending register called WKPND. The respective bits of the WKPND register will be set on the occurrence of the selected trigger edge on the corresponding Port L pin. The user has the responsibility of clearing these pending flags. Since WKPND is a pending register for the occurrence of selected wakeup conditions, the device will not enter the HALT mode if any Wakeup bit is both enabled and pending. Consequently, the user has the responsibility of clearing the pending flags before attempting to enter the HALT mode.

WKEN, WKPND and WKEDG are all read/write registers, and are cleared at reset.

PORT L INTERRUPTS

Port L provides the user with an additional eight fully selectable, edge sensitive interrupts which are all vectored into the same service subroutine.

The interrupt from Port L shares logic with the wake up circuitry. The register WKEN allows interrupts from Port L to be individually enabled or disabled. The register WKEDG specifies the trigger condition to be either a positive or a negative edge. Finally, the register WKPND latches in the pending trigger conditions.

The GIE (Global Interrupt Enable) bit enables the interrupt function.

A control flag, LPEN, functions as a global interrupt enable for Port L interrupts. Setting the LPEN flag will enable interrupts and vice versa. A separate global pending flag is not needed since the register WKPND is adequate.

Since Port L is also used for waking the device out of the HALT or IDLE modes, the user can elect to exit the HALT or IDLE modes either with or without the interrupt enabled. If he elects to disable the interrupt, then the device will restart execution from the instruction immediately following the instruction that placed the microcontroller in the HALT or IDLE modes. In the other case, the device will first execute the interrupt service routine and then revert to normal operation.

The Wakeup signal will not start the chip running immediately since crystal oscillators or ceramic resonators have a finite start up time. The IDLE Timer (T0) generates a fixed delay to ensure that the oscillator has indeed stabilized before allowing the device to execute instructions. In this case, upon detecting a valid Wakeup signal, only the oscillator circuitry and the IDLE Timer T0 are enabled. The IDLE Timer is loaded with a value of 256 and is clocked from the t_c instruction cycle clock. The t_c clock is derived by dividing down the oscillator clock by a factor of 10. A Schmitt trigger following the CKI on-chip inverter ensures that the IDLE timer is clocked only when the oscillator has a sufficiently large amplitude to meet the Schmitt trigger specifications. This Schmitt trigger is not part of the oscillator closed loop. The startup timeout from the IDLE timer enables the clock signals to be routed to the rest of the chip.

If the RC clock option is used, the fixed delay is under software control. A control flag, CLKDLY, in the G7 configuration bit allows the clock start up delay to be optionally inserted. Setting CLKDLY flag high will cause clock start up delay to be inserted and resetting it will exclude the clock start up delay. The CLKDLY flag is cleared during reset, so the clock start up delay is not present following reset with the RC clock options.

UART

The COP888CG contains a full-duplex software programmable UART. The UART (*Figure 11*) consists of a transmit shift register, a receiver shift register and seven addressable registers, as follows: a transmit buffer register (TBUF), a receiver buffer register (RBUF), a UART control and status register (ENUR), a UART receive control and status register (ENUI), a prescaler select register (PSR) and baud (BAUD) register. The ENUI register contains flags for transmit and receive functions; this register also determines the length of the data frame (7, 8 or 9 bits), the value of the ninth bit in transmission, and parity selection bits. The ENUR register flags framing, data overrun and parity errors while the UART is receiving.

Other functions of the ENUR register include saving the ninth bit received in the data frame, enabling or disabling the UART's attention mode of operation and providing additional receiver/transmitter status information via RCVG and XMTG bits. The determination of an internal or external clock source is done by the ENUI register, as well as selecting the number of stop bits and enabling or disabling transmit and receive interrupts. A control flag in this register can also select the UART mode of operation: asynchronous or synchronous.

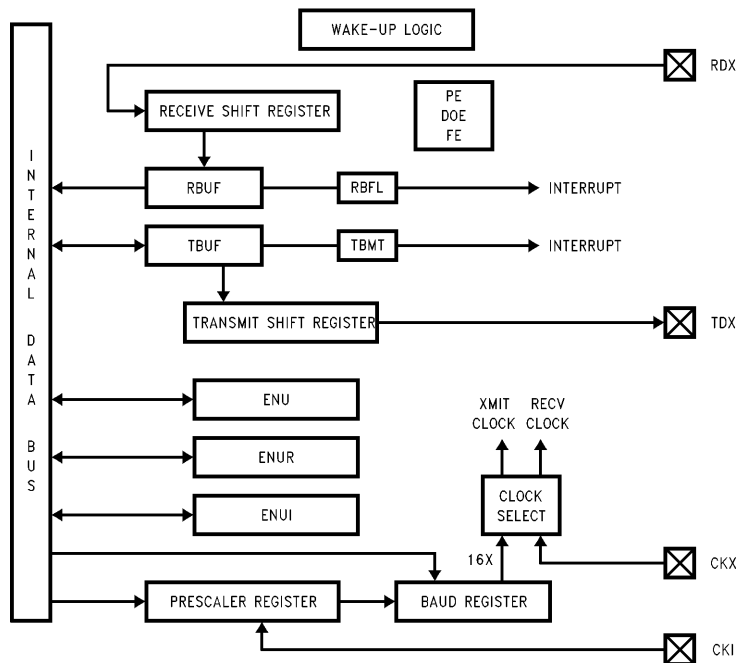

FIGURE 11. UART Block Diagram

TL/DD/9765-18

UART (Continued)

UART CONTROL AND STATUS REGISTERS

The operation of the UART is programmed through three registers: ENU, ENUR and ENUI. The function of the individual bits in these registers is as follows:

ENU-UART Control and Status Register (Address at 0BA)

PEN	PSEL1	XBIT9/ PSEL0	CHL1	CHL0	ERR	RBFL	TBMT
0RW	0RW	0RW	0RW	0RW	0R	0R	1R

Bit 7 Bit 0

ENUR-UART Receive Control and Status Register
(Address at 0BB)

DOE	FE	PE	SPARE	RBIT9	ATTN	XMTG	RCVG
0RD	0RD	0RD	0RW*	0R	0RW	0R	0R

Bit 7 Bit 0

ENUI-UART Interrupt and Clock Source Register
(Address at 0BC)

STP2	STP78	ETDX	SSEL	XRCLK	XTCLK	ERI	ETI
0RW	0RW	0RW	0RW	0RW	0RW	0RW	0RW

Bit 7 Bit 0

*Bit is not used.

0 Bit is cleared on reset.

1 Bit is set to one on reset.

R Bit is read-only; it cannot be written by software.

RW Bit is read/write.

D Bit is cleared on read; when read by software as a one, it is cleared automatically. Writing to the bit does not affect its state.

DESCRIPTION OF UART REGISTER BITS

ENU—UART CONTROL AND STATUS REGISTER

TBMT: This bit is set when the UART transfers a byte of data from the TBUF register into the TSFT register for transmission. It is automatically reset when software writes into the TBUF register.

RBFL: This bit is set when the UART has received a complete character and has copied it into the RBUF register. It is automatically reset when software reads the character from RBUF.

ERR: This bit is a global UART error flag which gets set if any or a combination of the errors (DOE, FE, PE) occur.

CHL1, CHL0: These bits select the character frame format. Parity is not included and is generated/verified by hardware.
 CHL1 = 0, CHL0 = 0 The frame contains eight data bits.
 CHL1 = 0, CHL0 = 1 The frame contains seven data bits.

CHL1 = 1, CHL0 = 0 The frame contains nine data bits.
 CHL1 = 1, CHL0 = 1 Loopback Mode selected. Transmitter output internally looped back to receiver input. Nine bit framing format is used.

XBIT9/PSEL0: Programs the ninth bit for transmission when the UART is operating with nine data bits per frame. For seven or eight data bits per frame, this bit in conjunction with PSEL1 selects parity.

PSEL1, PSEL0: Parity select bits.

PSEL1 = 0, PSEL0 = 0 Odd Parity (if Parity enabled)

PSEL1 = 0, PSEL0 = 1 Even Parity (if Parity enabled)

PSEL1 = 1, PSEL0 = 0 Mark(1) (if Parity enabled)

PSEL1 = 1, PSEL0 = 1 Space(0) (if Parity enabled)

PEN: This bit enables/disables Parity (7- and 8-bit modes only).

PEN = 0 Parity disabled.

PEN = 1 Parity enabled.

ENUR—UART RECEIVE CONTROL AND STATUS REGISTER

RCVG: This bit is set high whenever a framing error occurs and goes low when RDX goes high.

XMTG: This bit is set to indicate that the UART is transmitting. It gets reset at the end of the last frame (end of last Stop bit).

ATTN: ATTENTION Mode is enabled while this bit is set. This bit is cleared automatically on receiving a character with data bit nine set.

RBIT9: Contains the ninth data bit received when the UART is operating with nine data bits per frame.

SPARE: Reserved for future use.

PE: Flags a Parity Error.

PE = 0 Indicates no Parity Error has been detected since the last time the ENUR register was read.

PE = 1 Indicates the occurrence of a Parity Error.

FE: Flags a Framing Error.

FE = 0 Indicates no Framing Error has been detected since the last time the ENUR register was read.

FE = 1 Indicates the occurrence of a Framing Error.

DOE: Flags a Data Overrun Error.

DOE = 0 Indicates no Data Overrun Error has been detected since the last time the ENUR register was read.

DOE = 1 Indicates the occurrence of a Data Overrun Error.

ENUI—UART INTERRUPT AND CLOCK SOURCE REGISTER

ETI: This bit enables/disables interrupt from the transmitter section.

ETI = 0 Interrupt from the transmitter is disabled.

ETI = 1 Interrupt from the transmitter is enabled.

ERI: This bit enables/disables interrupt from the receiver section.

ERI = 0 Interrupt from the receiver is disabled.

ERI = 1 Interrupt from the receiver is enabled.

XTCLK: This bit selects the clock source for the transmitter-section.

XTCLK = 0 The clock source is selected through the PSR and BAUD registers.

XTCLK = 1 Signal on CKX (L1) pin is used as the clock.

XRCLK: This bit selects the clock source for the receiver section.

XRCLK = 0 The clock source is selected through the PSR and BAUD registers.

XRCLK = 1 Signal on CKX (L1) pin is used as the clock.

SSEL: UART mode select.

SSEL = 0 Asynchronous Mode.

SSEL = 1 Synchronous Mode.

UART (Continued)

ETDX: TDX (UART Transmit Pin) is the alternate function assigned to Port L pin L2; it is selected by setting ETDX bit. To simulate line break generation, software should reset ETDX bit and output logic zero to TDX pin through Port L data and configuration registers.

STP7: This bit is set to program the last Stop bit to be 7/8th of a bit in length.

STP2: This bit programs the number of Stop bits to be transmitted.

STP2 = 0 One Stop bit transmitted.

STP2 = 1 Two Stop bits transmitted.

Associated I/O Pins

Data is transmitted on the TDX pin and received on the RDX pin. TDX is the alternate function assigned to Port L pin L2; it is selected by setting ETDX (in the ENUI register) to one. RDX is an inherent function of Port L pin L3, requiring no setup.

The baud rate clock for the UART can be generated on-chip, or can be taken from an external source. Port L pin L1 (CKX) is the external clock I/O pin. The CKX pin can be either an input or an output, as determined by Port L Configuration and Data registers (Bit 1). As an input, it accepts a clock signal which may be selected to drive the transmitter and/or receiver. As an output, it presents the internal Baud Rate Generator output.

UART Operation

The UART has two modes of operation: asynchronous mode and synchronous mode.

ASYNCHRONOUS MODE

This mode is selected by resetting the SSEL (in the ENUI register) bit to zero. The input frequency to the UART is 16 times the baud rate.

The TSFT and TBUF registers double-buffer data for transmission. While TSFT is shifting out the current character on the TDX pin, the TBUF register may be loaded by software with the next byte to be transmitted. When TSFT finishes transmitting the current character the contents of TBUF are transferred to the TSFT register and the Transmit Buffer Empty Flag (TBMT in the ENU register) is set. The TBMT flag is automatically reset by the UART when software loads a new character into the TBUF register. There is also the XMTG bit which is set to indicate that the UART is transmitting. This bit gets reset at the end of the last frame (end of last Stop bit). TBUF is a read/write register.

The RSFT and RBUF registers double-buffer data being received. The UART receiver continually monitors the signal on the RDX pin for a low level to detect the beginning of a Start bit. Upon sensing this low level, it waits for half a bit time and samples again. If the RDX pin is still low, the receiver considers this to be a valid Start bit, and the remaining bits in the character frame are each sampled a single time, at the mid-bit position. Serial data input on the RDX pin is shifted into the RSFT register. Upon receiving the complete character, the contents of the RSFT register are copied into the RBUF register and the Received Buffer Full Flag (RBFL) is set. RBFL is automatically reset when software reads the character from the RBUF register. RBUF is a read only register. There is also the RCVG bit which is set high

when a framing error occurs and goes low once RDX goes high. TBMT, XMTG, RBFL and RCVG are read only bits.

SYNCHRONOUS MODE

In this mode data is transferred synchronously with the clock. Data is transmitted on the rising edge and received on the falling edge of the synchronous clock.

This mode is selected by setting SSEL bit in the ENUI register. The input frequency to the UART is the same as the baud rate.

When an external clock input is selected at the CKX pin, data transmit and receive are performed synchronously with this clock through TDX/RDX pins.

If data transmit and receive are selected with the CKX pin as clock output, the device generates the synchronous clock output at the CKX pin. The internal baud rate generator is used to produce the synchronous clock. Data transmit and receive are performed synchronously with this clock.

FRAMING FORMATS

The UART supports several serial framing formats (*Figure 12*). The format is selected using control bits in the ENU, ENUR and ENUI registers.

The first format (1, 1a, 1b, 1c) for data transmission (CHL0 = 1, CHL1 = 0) consists of Start bit, seven Data bits (excluding parity) and 7/8, one or two Stop bits. In applications using parity, the parity bit is generated and verified by hardware.

The second format (CHL0 = 0, CHL1 = 0) consists of one Start bit, eight Data bits (excluding parity) and 7/8, one or two Stop bits. Parity bit is generated and verified by hardware.

The third format for transmission (CHL0 = 0, CHL1 = 1) consists of one Start bit, nine Data bits and 7/8, one or two Stop bits. This format also supports the UART "ATTENTION" feature. When operating in this format, all eight bits of TBUF and RBUF are used for data. The ninth data bit is transmitted and received using two bits in the ENU and ENUR registers, called XBIT9 and RBIT9. RBIT9 is a read only bit. Parity is not generated or verified in this mode.

For any of the above framing formats, the last Stop bit can be programmed to be 7/8th of a bit in length. If two Stop bits are selected and the 7/8th bit is set (selected), the second Stop bit will be 7/8th of a bit in length.

The parity is enabled/disabled by PEN bit located in the ENU register. Parity is selected for 7- and 8-bit modes only. If parity is enabled (PEN = 1), the parity selection is then performed by PSEL0 and PSEL1 bits located in the ENU register.

Note that the XBIT9/PSEL0 bit located in the ENU register serves two mutually exclusive functions. This bit programs the ninth bit for transmission when the UART is operating with nine data bits per frame. There is no parity selection in this framing format. For other framing formats XBIT9 is not needed and the bit is PSEL0 used in conjunction with PSEL1 to select parity.

The frame formats for the receiver differ from the transmitter in the number of Stop bits required. The receiver only requires one Stop bit in a frame, regardless of the setting of the Stop bit selection bits in the control register. Note that an implicit assumption is made for full duplex UART operation that the framing formats are the same for the transmitter and receiver.

UART Operation (Continued)

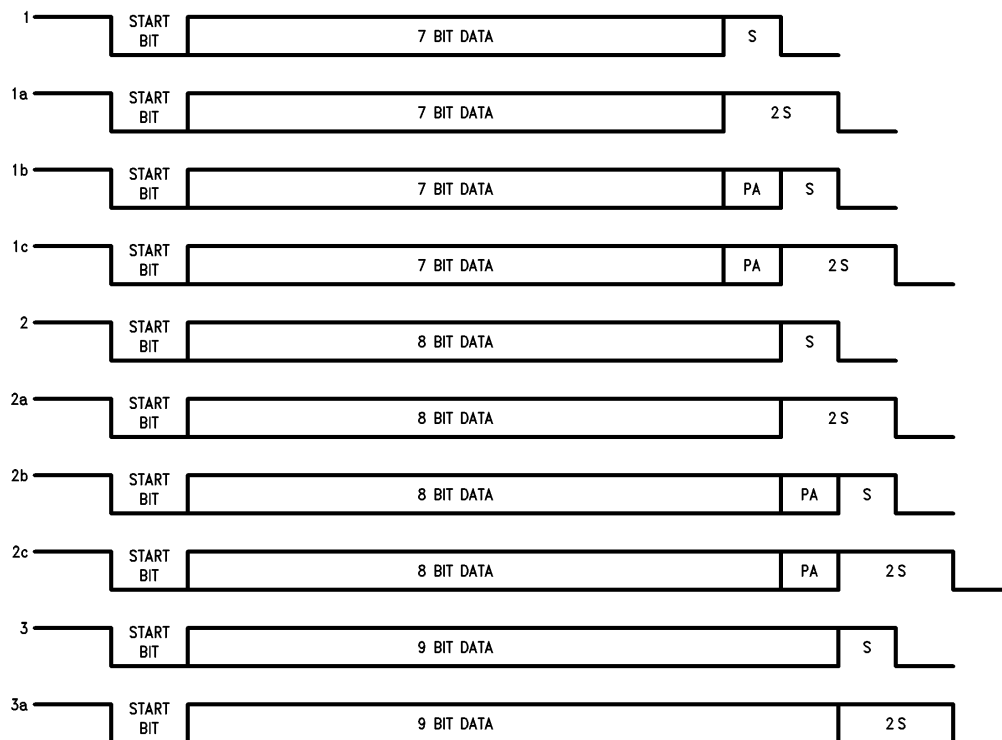

TL/DD/9765-19

FIGURE 12. Framing Formats

UART INTERRUPTS

The UART is capable of generating interrupts. Interrupts are generated on Receive Buffer Full and Transmit Buffer Empty. Both interrupts have individual interrupt vectors. Two bytes of program memory space are reserved for each interrupt vector. The two vectors are located at addresses 0xEC to 0xEF Hex in the program memory space. The interrupts can be individually enabled or disabled using Enable Transmit Interrupt (ETI) and Enable Receive Interrupt (ERI) bits in the ENUI register.

The interrupt from the Transmitter is set pending, and remains pending, as long as both the TBMT and ETI bits are set. To remove this interrupt, software must either clear the ETI bit or write to the TBUF register (thus clearing the TBMT bit).

The interrupt from the receiver is set pending, and remains pending, as long as both the RBFL and ERI bits are set. To remove this interrupt, software must either clear the ERI bit or read from the RBUF register (thus clearing the RBFL bit).

Baud Clock Generation

The clock inputs to the transmitter and receiver sections of the UART can be individually selected to come either from an external source at the CKX pin (port L, pin L1) or from a

source selected in the PSR and BAUD registers. Internally, the basic baud clock is created from the oscillator frequency through a two-stage divider chain consisting of a 1–16 (increments of 0.5) prescaler and an 11-bit binary counter. (Figure 13) The divide factors are specified through two read/write registers shown in Figure 14. Note that the 11-bit Baud Rate Divisor spills over into the Prescaler Select Register (PSR). PSR is cleared upon reset.

As shown in Table I, a Prescaler Factor of 0 corresponds to NO CLOCK. NO CLOCK condition is the UART power down mode where the UART clock is turned off for power saving purpose. The user must also turn the UART clock off when a different baud rate is chosen.

The correspondences between the 5-bit Prescaler Select and Prescaler factors are shown in Table I. There are many ways to calculate the two divisor factors, but one particularly effective method would be to achieve a 1.8432 MHz frequency coming out of the first stage. The 1.8432 MHz prescaler output is then used to drive the software programmable baud rate counter to create a x16 clock for the following baud rates: 110, 134.5, 150, 300, 600, 1200, 1800, 2400, 3600, 4800, 7200, 9600, 19200 and 38400 (Table II). Other baud rates may be created by using appropriate divisors. The x16 clock is then divided by 16 to provide the rate for the serial shift registers of the transmitter and receiver.

Baud Clock Generation (Continued)

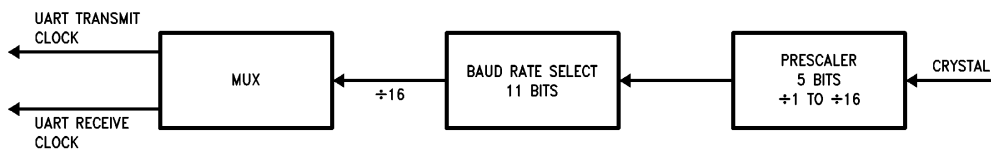

TL/DD/9765-20

FIGURE 13. UART BAUD Clock Generation

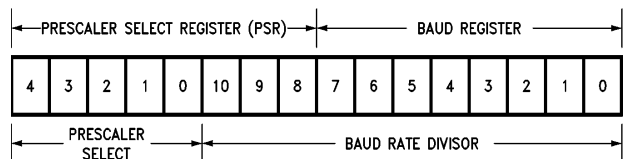

TL/DD/9765-21

FIGURE 14. UART BAUD Clock Divisor Registers

TABLE I. Prescaler Factors

Prescaler Select	Prescaler Factor
00000	NO CLOCK
00001	1
00010	1.5
00011	2
00100	2.5
00101	3
00110	3.5
00111	4
01000	4.5
01001	5
01010	5.5
01011	6
01100	6.5
01101	7
01110	7.5
01111	8
10000	8.5
10001	9
10010	9.5
10011	10
10100	10.5
10101	11
10110	11.5
10111	12
11000	12.5
11001	13
11010	13.5
11011	14
11100	14.5
11101	15
11110	15.5
11111	16

TABLE II. Baud Rate Divisors
(1.8432 MHz Prescaler Output)

Baud Rate	Baud Rate Divisor - 1 (N-1)
110 (110.03)	1046
134.5 (134.58)	855
150	767
300	383
600	191
1200	95
1800	63
2400	47
3600	31
4800	23
7200	15
9600	11
19200	5
38400	2

The entries in Table II assume a prescaler output of 1.8432 MHz. In the asynchronous mode the baud rate could be as high as 625k.

As an example, considering the Asynchronous Mode and a CKI clock of 4.608 MHz, the prescaler factor selected is:

$$4.608 / 1.8432 = 2.5$$

The 2.5 entry is available in Table I. The 1.8432 MHz prescaler output is then used with proper Baud Rate Divisor (Table II) to obtain different baud rates. For a baud rate of 19200 e.g., the entry in Table II is 5.

$$N - 1 = 5 \quad (N - 1 \text{ is the value from Table II})$$

$$N = 6 \quad (N \text{ is the Baud Rate Divisor})$$

$$\text{Baud Rate} = 1.8432 \text{ MHz} / (16 \times 6) = 19200$$

The divide by 16 is performed because in the asynchronous mode, the input frequency to the UART is 16 times the baud rate. The equation to calculate baud rates is given below.

The actual Baud Rate may be found from:

$$BR = Fc / (16 \times N \times P)$$

Baud Clock Generation (Continued)

Where:

BR is the Baud Rate

Fc is the CKI frequency

N is the Baud Rate Divisor (Table II).

P is the Prescaler Divide Factor selected by the value in the Prescaler Select Register (Table I)

Note: In the Synchronous Mode, the divisor 16 is replaced by two.

Example:

Asynchronous Mode:

$$\text{Crystal Frequency} = 5 \text{ MHz}$$

$$\text{Desired baud rate} = 9600$$

Using the above equation $N \times P$ can be calculated first.

$$N \times P = (5 \times 10^6) / (16 \times 9600) = 32.552$$

Now 32.552 is divided by each Prescaler Factor (Table II) to obtain a value closest to an integer. This factor happens to be 6.5 ($P = 6.5$).

$$N = 32.552 / 6.5 = 5.008 \quad (N = 5)$$

The programmed value (from Table II) should be 4 ($N - 1$).

Using the above values calculated for N and P:

$$BR = (5 \times 10^6) / (16 \times 5 \times 6.5) = 9615.384$$

$$\% \text{ error} = (9615.385 - 9600) / 9600 = 0.16$$

Effect of HALT/IDLE

The UART logic is reinitialized when either the HALT or IDLE modes are entered. This reinitialization sets the TBMT flag and resets all read only bits in the UART control and status registers. Read/Write bits remain unchanged. The Transmit Buffer (TBUF) is not affected, but the Transmit Shift register (TSFT) bits are set to one. The receiver registers RBUF and RSFT are not affected.

The device will exit from the HALT/IDLE modes when the Start bit of a character is detected at the RDX (L3) pin. This feature is obtained by using the Multi-Input Wakeup scheme provided on the device.

Before entering the HALT or IDLE modes the user program must select the Wakeup source to be on the RDX pin. This selection is done by setting bit 3 of WKEN (Wakeup Enable) register. The Wakeup trigger condition is then selected to be high to low transition. This is done via the WKEDG register (Bit 3 is one.)

If the device is halted and crystal oscillator is used, the Wakeup signal will not start the chip running immediately because of the finite start up time requirement of the crystal oscillator. The idle timer (T0) generates a fixed (256 t_c) delay to ensure that the oscillator has indeed stabilized before allowing the device to execute code. The user has to consider this delay when data transfer is expected immediately after exiting the HALT mode.

Diagnostic

Bits CHARL0 and CHARL1 in the ENU register provide a loopback feature for diagnostic testing of the UART. When these bits are set to one, the following occur: The receiver input pin (RDX) is internally connected to the transmitter output pin (TDX); the output of the Transmitter Shift Register is "looped back" into the Receive Shift Register input. In this mode, data that is transmitted is immediately received. This feature allows the processor to verify the transmit and receive data paths of the UART.

Note that the framing format for this mode is the nine bit format; one Start bit, nine data bits, and 7/8, one or two Stop bits. Parity is not generated or verified in this mode.

Attention Mode

The UART Receiver section supports an alternate mode of operation, referred to as ATTENTION Mode. This mode of operation is selected by the ATTN bit in the ENUR register. The data format for transmission must also be selected as having nine Data bits and either 7/8, one or two Stop bits. The ATTENTION mode of operation is intended for use in networking the device with other processors. Typically in such environments the messages consists of device addresses, indicating which of several destinations should receive them, and the actual data. This Mode supports a scheme in which addresses are flagged by having the ninth bit of the data field set to a 1. If the ninth bit is reset to a zero the byte is a Data byte.

While in ATTENTION mode, the UART monitors the communication flow, but ignores all characters until an address character is received. Upon receiving an address character, the UART signals that the character is ready by setting the RBFL flag, which in turn interrupts the processor if UART Receiver interrupts are enabled. The ATTN bit is also cleared automatically at this point, so that data characters as well as address characters are recognized. Software examines the contents of the RBUF and responds by deciding either to accept the subsequent data stream (by leaving the ATTN bit reset) or to wait until the next address character is seen (by setting the ATTN bit again).

Operation of the UART Transmitter is not affected by selection of this Mode. The value of the ninth bit to be transmitted is programmed by setting XBIT9 appropriately. The value of the ninth bit received is obtained by reading RBIT9. Since this bit is located in ENUR register where the error flags reside, a bit operation on it will reset the error flags.

Comparators

The device contains two differential comparators, each with a pair of inputs (positive and negative) and an output. Ports I1-I3 and I4-I6 are used for the comparators. The following is the Port I assignment:

- I1 Comparator1 negative input
- I2 Comparator1 positive input
- I3 Comparator1 output
- I4 Comparator2 negative input
- I5 Comparator2 positive input
- I6 Comparator2 output

A Comparator Select Register (CMPSL) is used to enable the comparators, read the outputs of the comparators internally, and enable the outputs of the comparators to the pins. Two control bits (enable and output enable) and one result bit are associated with each comparator. The comparator result bits (CMP1RD and CMP2RD) are read only bits which will read as zero if the associated comparator is not enabled. The Comparator Select Register is cleared with reset, resulting in the comparators being disabled. The comparators should also be disabled before entering either the HALT or IDLE modes in order to save power. The configuration of the CMPSL register is as follows:

Comparators (Continued)

CMPSL REGISTER (ADDRESS X'00B7)

The CMPSL register contains the following bits:

- CMP1EN Enable comparator 1
- CMP1RD Comparator 1 result (this is a read only bit, which will read as 0 if the comparator is not enabled)
- CMP10E Selects pin I3 as comparator 1 output provided that CMPIEN is set to enable the comparator
- CMP2EN Enable comparator 2
- CMP2RD Comparator 2 result (this is a read only bit, which will read as 0 if the comparator is not enabled)
- CMP20E Selects pin I6 as comparator 2 output provided that CMP2EN is set to enable the comparator

Unused	CMP20E	CMP2RD	CMP2EN	CMP10E	CMP1RD	CMP1EN	Unused
Bit 7							Bit 0

Note that the two unused bits of CMPSL may be used as software flags.

Comparator outputs have the same spec as Ports L and G except that the rise and fall times are symmetrical.

Interrupts

The device supports a vectored interrupt scheme. It supports a total of fourteen interrupt sources. The following table lists all the possible device interrupt sources, their arbitration ranking and the memory locations reserved for the interrupt vector for each source.

Two bytes of program memory space are reserved for each interrupt source. All interrupt sources except the software interrupt are maskable. Each of the maskable interrupts have an Enable bit and a Pending bit. A maskable interrupt is active if its associated enable and pending bits are set. If $GIE = 1$ and an interrupt is active, then the processor will be interrupted as soon as it is ready to start executing an instruction except if the above conditions happen during the Software Trap service routine. This exception is described in the Software Trap sub-section.

The interruption process is accomplished with the INTR instruction (opcode 00), which is jammed inside the Instruction Register and replaces the opcode about to be executed. The following steps are performed for every interrupt:

1. The GIE (Global Interrupt Enable) bit is reset.
2. The address of the instruction about to be executed is pushed into the stack.
3. The PC (Program Counter) branches to address 00FF. This procedure takes $7 t_c$ cycles to execute.

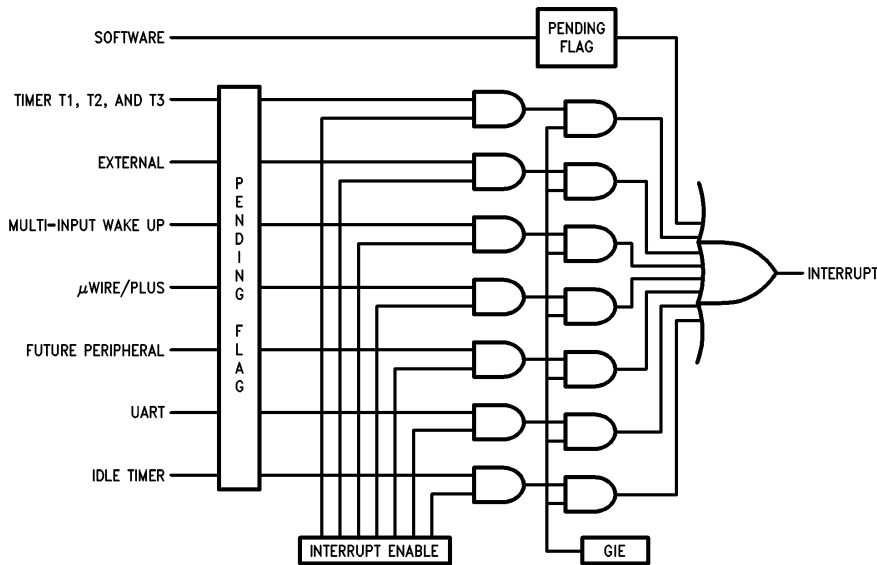

FIGURE 15. Interrupt Block Diagram

TL/DD/9765-22

Interrupts (Continued)

Arbitration Ranking	Source	Description	Vector Address Hi-Low Byte
(1) Highest	Software	INTR Instruction	0yFE–0yFF
	Reserved	for Future Use	0yFC–0yFD
(2)	External	Pin G0 Edge	0yFA–0yFB
(3)	Timer T0	Underflow	0yF8–0yF9
(4)	Timer T1	T1A/Underflow	0yF6–0yF7
(5)	Timer T1	T1B	0yF4–0yF5
(6)	MICROWIRE/PLUS	BUSY Goes Low	0yF2–0yF3
	Reserved	for Future Use	0yF0–0yF1
(7)	UART	Receive	0yEE–0yEF
(8)	UART	Transmit	0yEC–0yED
(9)	Timer T2	T2A/Underflow	0yEA–0yEB
(10)	Timer T2	T2B	0yE8–0yE9
(11)	Timer T3	T3A/Underflow	0yE6–0yE7
(12)	Timer T3	T3B	0yE4–0yE5
(13)	Port L/Wakeup	Port L Edge	0yE2–0yE3
(14) Lowest	Default	VIS Instr. Execution without Any Interrupts	0yE0–0yE1

y is VIS page, y ≠ 0.

At this time, since GIE = 0, other maskable interrupts are disabled. The user is now free to do whatever context switching is required by saving the context of the machine in the stack with PUSH instructions. The user would then program a VIS (Vector Interrupt Select) instruction in order to branch to the interrupt service routine of the highest priority interrupt enabled and pending at the time of the VIS. Note that this is not necessarily the interrupt that caused the branch to address location 00FF Hex prior to the context switching.

Thus, if an interrupt with a higher rank than the one which caused the interruption becomes active before the decision of which interrupt to service is made by the VIS, then the interrupt with the higher rank will override any lower ones and will be acknowledged. The lower priority interrupt(s) are still pending, however, and will cause another interrupt immediately following the completion of the interrupt service routine associated with the higher priority interrupt just serviced. This lower priority interrupt will occur immediately following the RETI (Return from Interrupt) instruction at the end of the interrupt service routine just completed.

Inside the interrupt service routine, the associated pending bit has to be cleared by software. The RETI (Return from Interrupt) instruction at the end of the interrupt service routine will set the GIE (Global Interrupt Enable) bit, allowing the processor to be interrupted again if another interrupt is active and pending.

The VIS instruction looks at all the active interrupts at the time it is executed and performs an indirect jump to the beginning of the service routine of the one with the highest rank.

The addresses of the different interrupt service routines, called vectors, are chosen by the user and stored in ROM in

a table starting at 01E0 (assuming that VIS is located between 00FF and 01DF). The vectors are 15-bit wide and therefore occupy 2 ROM locations.

VIS and the vector table must be located in the same 256-byte block (0y00 to 0yFF) except if VIS is located at the last address of a block. In this case, the table must be in the next block. The vector table cannot be inserted in the first 256-byte block (y ≠ 0).

The vector of the maskable interrupt with the lowest rank is located at 0yE0 (Hi-Order byte) and 0yE1 (Lo-Order byte) and so forth in increasing rank number. The vector of the maskable interrupt with the highest rank is located at 0yFA (Hi-Order byte) and 0yFB (Lo-Order byte).

The Software Trap has the highest rank and its vector is located at 0yFE and 0yFF.

If, by accident, a VIS gets executed and no interrupt is active, then the PC (Program Counter) will branch to a vector located at 0yE0–0yE1.

WARNING; A Default VIS interrupt handler routine must be present. As a minimum, this handler should confirm that the GIE bit is cleared (this indicates that the interrupt sequence has been taken), take care of any required housekeeping, restore context and return. Some sort of Warm Restart procedure should be implemented. These events can occur without any error on the part of the system designer or programmer.

Note: There is always the possibility of an interrupt occurring during an instruction which is attempting to reset the GIE bit or any other interrupt enable bit. If this occurs when a single cycle instruction is being used to reset the interrupt enable bit, the interrupt enable bit will be reset but an interrupt may still occur. This is because interrupt processing is started at the same time as the interrupt bit is being reset. To avoid this scenario, the user should always use a two, three, or four cycle instruction to reset interrupt enable bits.

Figure 15 shows the Interrupt block diagram.

Interrupts (Continued)

SOFTWARE TRAP

The Software Trap (ST) is a special kind of non-maskable interrupt which occurs when the INTR instruction (used to acknowledge interrupts) is fetched from ROM and placed inside the instruction register. This may happen when the PC is pointing beyond the available ROM address space or when the stack is over-popped.

When an ST occurs, the user can re-initialize the stack pointer and do a recovery procedure (similar to reset, but not necessarily containing all of the same initialization procedures) before restarting.

The occurrence of an ST is latched into the ST pending bit. The GIE bit is not affected and the ST pending bit (**not accessible by the user**) is used to inhibit other interrupts and to direct the program to the ST service routine with the VIS instruction. The RPNL instruction is used to clear the software interrupt pending bit. This pending bit is also cleared on reset.

The ST has the highest rank among all interrupts.

Nothing (except another ST) can interrupt an ST being serviced.

WATCHDOG

The device contains a WATCHDOG and clock monitor. The WATCHDOG is designed to detect the user program getting stuck in infinite loops resulting in loss of program control or "runaway" programs. The Clock Monitor is used to detect the absence of a clock or a very slow clock below a specified rate on the CKI pin.

The WATCHDOG consists of two independent logic blocks: WD UPPER and WD LOWER. WD UPPER establishes the upper limit on the service window and WD LOWER defines the lower limit of the service window.

Servicing the WATCHDOG consists of writing a specific value to a WATCHDOG Service Register named WDSVR which is memory mapped in the RAM. This value is composed of three fields, consisting of a 2-bit Window Select, a 5-bit Key Data field, and the 1-bit Clock Monitor Select field. Table III shows the WDSVR register.

The lower limit of the service window is fixed at 2048 instruction cycles. Bits 7 and 6 of the WDSVR register allow the user to pick an upper limit of the service window.

Table IV shows the four possible combinations of lower and upper limits for the WATCHDOG service window. This flexibility in choosing the WATCHDOG service window prevents any undue burden on the user software.

Bits 5, 4, 3, 2 and 1 of the WDSVR register represent the 5-bit Key Data field. The key data is fixed at 01100. Bit 0 of the WDSVR Register is the Clock Monitor Select bit.

TABLE III. WATCHDOG Service Register (WDSVR)

Window Select		Key Data					Clock Monitor
X	X	0	1	1	0	0	Y
7	6	5	4	3	2	1	0

TABLE IV. WATCHDOG Service Window Select

WDSVR Bit 7	WDSVR Bit 6	Service Window (Lower-Upper Limits)
0	0	2k–8k t_c Cycles
0	1	2k–16k t_c Cycles
1	0	2k–32k t_c Cycles
1	1	2k–64k t_c Cycles

Clock Monitor

The Clock Monitor aboard the device can be selected or deselected under program control. The Clock Monitor is guaranteed not to reject the clock if the instruction cycle clock ($1/t_c$) is greater or equal to 10 kHz. This equates to a clock input rate on CKI of greater or equal to 100 kHz.

WATCHDOG Operation

The WATCHDOG and Clock Monitor are disabled during reset. The device comes out of reset with the WATCHDOG armed, the WATCHDOG Window Select bits (bits 6, 7 of the WDSVR Register) set, and the Clock Monitor bit (bit 0 of the WDSVR Register) enabled. Thus, a Clock Monitor error will occur after coming out of reset, if the instruction cycle clock frequency has not reached a minimum specified value, including the case where the oscillator fails to start.

The WDSVR register can be written to only once after reset and the key data (bits 5 through 1 of the WDSVR Register) must match to be a valid write. This write to the WDSVR register involves two irrevocable choices: (i) the selection of the WATCHDOG service window (ii) enabling or disabling of the Clock Monitor. Hence, the first write to WDSVR Register involves selecting or deselecting the Clock Monitor, select the WATCHDOG service window and match the WATCHDOG key data. Subsequent writes to the WDSVR register will compare the value being written by the user to the WATCHDOG service window value and the key data (bits 7 through 1) in the WDSVR Register. Table V shows the sequence of events that can occur.

The user must service the WATCHDOG at least once before the upper limit of the service window expires. The WATCHDOG may not be serviced more than once in every lower limit of the service window. The user may service the WATCHDOG as many times as wished in the time period between the lower and upper limits of the service window. The first write to the WDSVR Register is also counted as a WATCHDOG service.

The WATCHDOG has an output pin associated with it. This is the WDOOUT pin, on pin 1 of the port G. WDOOUT is active low. The WDOOUT pin is in the high impedance state in the inactive state. Upon triggering the WATCHDOG, the logic will pull the WDOOUT (G1) pin low for an additional 16 t_c –32 t_c cycles after the signal level on WDOOUT pin goes below the lower Schmitt trigger threshold. After this delay, the device will stop forcing the WDOOUT output low.

WATCHDOG Operation (Continued)

The WATCHDOG service window will restart when the WDOUT pin goes high. It is recommended that the user tie the WDOUT pin back to V_{CC} through a resistor in order to pull WDOUT high.

A WATCHDOG service while the WDOUT signal is active will be ignored. The state of the WDOUT pin is not guaranteed on reset, but if it powers up low then the WATCHDOG will time out and WDOUT will enter high impedance state.

The Clock Monitor forces the G1 pin low upon detecting a clock frequency error. The Clock Monitor error will continue until the clock frequency has reached the minimum specified value, after which the G1 output will enter the high impedance TRI-STATE mode following $16 t_c$ – $32 t_c$ clock cycles. The Clock Monitor generates a continual Clock Monitor error if the oscillator fails to start, or fails to reach the minimum specified frequency. The specification for the Clock Monitor is as follows:

$1/t_c > 10$ kHz—No clock rejection.

$1/t_c < 10$ Hz—Guaranteed clock rejection.

Watchdog and Clock Monitor Summary

The following salient points regarding the WATCHDOG and CLOCK MONITOR should be noted:

- Both the WATCHDOG and CLOCK MONITOR detector circuits are inhibited during RESET.
- Following RESET, the WATCHDOG and CLOCK MONITOR are both enabled, with the WATCHDOG having the maximum service window selected.
- The WATCHDOG service window and CLOCK MONITOR enable/disable option can only be changed once, during the initial WATCHDOG service following RESET.
- The initial WATCHDOG service must match the key data value in the WATCHDOG Service register WDSVR in order to avoid a WATCHDOG error.
- Subsequent WATCHDOG services must match all three data fields in WDSVR in order to avoid WATCHDOG errors.
- The correct key data value cannot be read from the WATCHDOG Service register WDSVR. Any attempt to read this key data value of 01100 from WDSVR will read as key data value of all 0's.
- The WATCHDOG detector circuit is inhibited during both the HALT and IDLE modes.
- The CLOCK MONITOR detector circuit is active during both the HALT and IDLE modes. Consequently, the device inadvertently entering the HALT mode will be detected as a CLOCK MONITOR error (provided that the CLOCK MONITOR enable option has been selected by the program).
- With the single-pin R/C oscillator mask option selected and the CLKDLY bit reset, the WATCHDOG service window will resume following HALT mode from where it left off before entering the HALT mode.
- With the crystal oscillator mask option selected, or with the single-pin R/C oscillator mask option selected and the CLKDLY bit set, the WATCHDOG service window will be set to its selected value from WDSVR following HALT. Consequently, the WATCHDOG should not be serviced for at least 2048 instruction cycles following HALT, but must be serviced within the selected window to avoid a WATCHDOG error.
- The IDLE timer T0 is not initialized with RESET.
- The user can sync in to the IDLE counter cycle with an IDLE counter (T0) interrupt or by monitoring the TOPND flag. The TOPND flag is set whenever the thirteenth bit of the IDLE counter toggles (every 4096 instruction cycles). The user is responsible for resetting the TOPND flag.
- A hardware WATCHDOG service occurs just as the device exits the IDLE mode. Consequently, the WATCHDOG should not be serviced for at least 2048 instruction cycles following IDLE, but must be serviced within the selected window to avoid a WATCHDOG error.
- Following RESET, the initial WATCHDOG service (where the service window and the CLOCK MONITOR enable/disable must be selected) may be programmed anywhere within the maximum service window (65,536 instruction cycles) initialized by RESET. Note that this initial WATCHDOG service may be programmed within the initial 2048 instruction cycles without causing a WATCHDOG error.

Detection of Illegal Conditions

The device can detect various illegal conditions resulting from coding errors, transient noise, power supply voltage drops, runaway programs, etc.

Reading of undefined ROM gets zeros. The opcode for software interrupt is zero. If the program fetches instructions from undefined ROM, this will force a software interrupt, thus signaling that an illegal condition has occurred.

The subroutine stack grows down for each call (jump to subroutine), interrupt, or PUSH, and grows up for each return or POP. The stack pointer is initialized to RAM location 06F Hex during reset. Consequently, if there are more returns than calls, the stack pointer will point to addresses 070 and 071 Hex (which are undefined RAM). Undefined RAM from addresses 070 to 07F (Segment 0), 140 to 17F (Segment 1), and all other segments (i.e., Segments 3 . . . etc.) is read as all 1's, which in turn will cause the program to return to address 7FFF Hex. This is an undefined ROM location and the instruction fetched (all 0's) from this location will generate a software interrupt signaling an illegal condition.

Thus, the chip can detect the following illegal conditions:

- a. Executing from undefined ROM
- b. Over "POP"ing the stack by having more returns than calls.

When the software interrupt occurs, the user can re-initialize the stack pointer and do a recovery procedure before re-starting (this recovery program is probably similar to that following reset, but might not contain the same program initialization procedures). The recovery program should reset the software interrupt pending bit using the RPND instruction.

MICROWIRE/PLUS

MICROWIRE/PLUS is a serial synchronous communications interface. The MICROWIRE/PLUS capability enables the device to interface with any of National Semiconductor's MICROWIRE peripherals (i.e. A/D converters, display drivers, E²PROMs etc.) and with other microcontrollers which support the MICROWIRE interface. It consists of an 8-bit serial shift register (SIO) with serial data input (SI), serial data output (SO) and serial shift clock (SK). Figure 12 shows a block diagram of the MICROWIRE/PLUS logic.

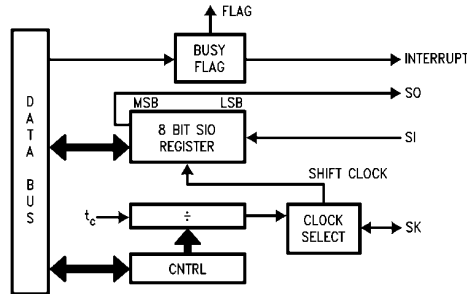

TL/DD/9765-23

FIGURE 16. MICROWIRE/PLUS Block Diagram

The shift clock can be selected from either an internal source or an external source. Operating the MICROWIRE/PLUS arrangement with the internal clock source is called the Master mode of operation. Similarly, operating the MICROWIRE/PLUS arrangement with an external shift clock is called the Slave mode of operation.

The CNTRL register is used to configure and control the MICROWIRE/PLUS mode. To use the MICROWIRE/PLUS, the MSEL bit in the CNTRL register is set to one. In the master mode, the SK clock rate is selected by the two bits, SL0 and SL1, in the CNTRL register. Table VI details the different clock rates that may be selected.

TABLE V. WATCHDOG Service Actions

Key Data	Window Data	Clock Monitor	Action
Match	Match	Match	Valid Service: Restart Service Window
Don't Care	Mismatch	Don't Care	Error: Generate WATCHDOG Output
Mismatch	Don't Care	Don't Care	Error: Generate WATCHDOG Output
Don't Care	Don't Care	Mismatch	Error: Generate WATCHDOG Output

TABLE VI. MICROWIRE/PLUS Master Mode Clock Select

SL1	SL0	SK
0	0	$2 \times t_c$
0	1	$4 \times t_c$
1	x	$8 \times t_c$

Where t_c is the instruction cycle clock

MICROWIRE/PLUS (Continued)

MICROWIRE/PLUS OPERATION

Setting the BUSY bit in the PSW register causes the MICROWIRE/PLUS to start shifting the data. It gets reset when eight data bits have been shifted. The user may reset the BUSY bit by software to allow less than 8 bits to shift. If enabled, an interrupt is generated when eight data bits have been shifted. The device may enter the MICROWIRE/PLUS mode either as a Master or as a Slave. Figure 13 shows how two devices, microcontrollers and several peripherals may be interconnected using the MICROWIRE/PLUS arrangements.

Warning:

The SIO register should only be loaded when the SK clock is low. Loading the SIO register while the SK clock is high will result in undefined data in the SIO register. SK clock is normally low when not shifting.

Setting the BUSY flag when the input SK clock is high in the MICROWIRE/PLUS slave mode may cause the current SK clock for the SIO shift register to be narrow. For safety, the BUSY flag should only be set when the input SK clock is low.

MICROWIRE/PLUS Master Mode Operation

In the MICROWIRE/PLUS Master mode of operation the shift clock (SK) is generated internally. The MICROWIRE Master always initiates all data exchanges. The MSEL bit in the CNTRL register must be set to enable the SO and SK functions onto the G Port. The SO and SK pins must also be selected as outputs by setting appropriate bits in the Port G configuration register. Table VII summarizes the bit settings required for Master mode of operation.

MICROWIRE/PLUS Slave Mode Operation

In the MICROWIRE/PLUS Slave mode of operation the SK clock is generated by an external source. Setting the MSEL bit in the CNTRL register enables the SO and SK functions onto the G Port. The SK pin must be selected as an input and the SO pin is selected as an output pin by setting and resetting the appropriate bit in the Port G configuration register. Table VII summarizes the settings required to enter the Slave mode of operation.

The user must set the BUSY flag immediately upon entering the Slave mode. This will ensure that all data bits sent by the Master will be shifted properly. After eight clock pulses the BUSY flag will be cleared and the sequence may be repeated.

Alternate SK Phase Operation

The device allows either the normal SK clock or an alternate phase SK clock to shift data in and out of the SIO register. In both the modes the SK is normally low. In the normal mode data is shifted in on the rising edge of the SK clock and the data is shifted out on the falling edge of the SK clock. The SIO register is shifted on each falling edge of the SK clock. In the alternate SK phase operation, data is shifted in on the falling edge of the SK clock and shifted out on the rising edge of the SK clock.

A control flag, SKSEL, allows either the normal SK clock or the alternate SK clock to be selected. Resetting SKSEL causes the MICROWIRE/PLUS logic to be clocked from the normal SK signal. Setting the SKSEL flag selects the alternate SK clock. The SKSEL is mapped into the G6 configuration bit. The SKSEL flag will power up in the reset condition, selecting the normal SK signal.

TABLE VII

This table assumes that the control flag MSEL is set.

G4 (SO) Config. Bit	G5 (SK) Config. Bit	G4 Fun.	G5 Fun.	Operation
1	1	SO	Int. SK	MICROWIRE/PLUS Master
0	1	TRI-STATE	Int. SK	MICROWIRE/PLUS Master
1	0	SO	Ext. SK	MICROWIRE/PLUS Slave
0	0	TRI-STATE	Ext. SK	MICROWIRE/PLUS Slave

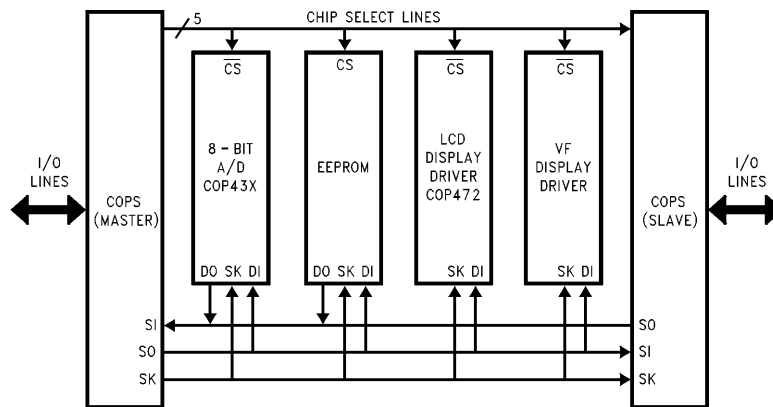

FIGURE 17. MICROWIRE/PLUS Application

TL/DD/9765-24

Memory Map

All RAM, ports and registers (except A and PC) are mapped into data memory address space.

Address S/ADD REG	Contents	Address S/ADD REG	Contents
0000 to 006F	On-Chip RAM bytes (112 bytes)	xxD0	Port L Data Register
0070 to 007F	Unused RAM Address Space (Reads As All Ones)	xxD1	Port L Configuration Register
xx80 to xxAF	Unused RAM Address Space (Reads Undefined Data)	xxD2	Port L Input Pins (Read Only)
xxB0	Timer T3 Lower Byte	xxD3	Reserved for Port L
XXB1	Timer T3 Upper Byte	xxD4	Port G Data Register
xxB2	Timer T3 Autoload Register T3RA Lower Byte	xxD5	Port G Configuration Register
xxB3	Timer T3 Autoload Register T3RA Upper Byte	xxD6	Port G Input Pins (Read Only)
xxB4	Timer T3 Autoload Register T3RB Lower Byte	xxD7	Port I Input Pins (Read Only)
xxB5	Timer T3 Autoload Register T3RB Upper Byte	xxD8	Port C Data Register
xxB6	Timer T3 Control Register	xxD9	Port C Configuration Register
xxB7	Comparator Select Register (CMPSL)	xxDA	Port C Input Pins (Read Only)
xxB8	UART Transmit Buffer (TBUF)	xxDB	Reserved for Port C
xxB9	UART Receive Buffer (RBUF)	xxDC	Port D
xxBA	UART Control and Status Register (ENU)	xxDD to DF	Reserved for Port D
xxBB	UART Receive Control and Status Register (ENUR)	xxE0 to xxE5	Reserved for EE Control Registers
xxBC	UART Interrupt and Clock Source Register (ENUI)	xxE6	Timer T1 Autoload Register T1RB Lower Byte
xxBD	UART Baud Register (BAUD)	xxE7	Timer T1 Autoload Register T1RB Upper Byte
xxBE	UART Prescale Select Register (PSR)	xxE8	ICNTRL Register
xxBF	Reserved for UART	xxE9	MICROWIRE/PLUS Shift Register
xxC0	Timer T2 Lower Byte	xxEA	Timer T1 Lower Byte
xxC1	Timer T2 Upper Byte	xxEB	Timer T1 Upper Byte
xxC2	Timer T2 Autoload Register T2RA Lower Byte	xxEC	Timer T1 Autoload Register T1RA Lower Byte
xxC3	Timer T2 Autoload Register T2RA Upper Byte	xxED	Timer T1 Autoload Register T1RA Upper Byte
xxC4	Timer T2 Autoload Register T2RB Lower Byte	xxEE	CNTRL Control Register
xxC5	Timer T2 Autoload Register T2RB Upper Byte	xxEF	PSW Register
xxC6	Timer T2 Control Register	xxF0 to FB	On-Chip RAM Mapped as Registers
xxC7	WATCHDOG Service Register (Reg:WDSVR)	xxFC	X Register
xxC8	MIWU Edge Select Register (Reg:WKEDG)	xxFD	SP Register
xxC9	MIWU Enable Register (Reg:WKEN)	xxFE	B Register
xxCA	MIWU Pending Register (Reg:WKPND)	xxFF	S Register
xxCB	Reserved	0100–013F	On-Chip 64 RAM Bytes
xxCC	Reserved		
xxCD to xxCF	Reserved		

Reading memory locations 0070H–007FH (Segment 0) will return all ones. Reading unused memory locations 0080H–00AFH (Segment 0) will return undefined data. Reading unused memory locations 0140–017F (Segment 1) will return all ones. Reading memory locations from other Segments (i.e., Segment 2, Segment 3, ... etc.) will return all ones.

Addressing Modes

There are ten addressing modes, six for operand addressing and four for transfer of control.

OPERAND ADDRESSING MODES

Register Indirect

This is the “normal” addressing mode. The operand is the data memory addressed by the B pointer or X pointer.

Register Indirect (with auto post increment or decrement of pointer)

This addressing mode is used with the LD and X instructions. The operand is the data memory addressed by the B pointer or X pointer. This is a register indirect mode that automatically post increments or decrements the B or X register after executing the instruction.

Direct

The instruction contains an 8-bit address field that directly points to the data memory for the operand.

Immediate

The instruction contains an 8-bit immediate field as the operand.

Short Immediate

This addressing mode is used with the Load B Immediate instruction. The instruction contains a 4-bit immediate field as the operand.

Indirect

This addressing mode is used with the LAID instruction. The contents of the accumulator are used as a partial address (lower 8 bits of PC) for accessing a data operand from the program memory.

TRANSFER OF CONTROL ADDRESSING MODES

Relative

This mode is used for the JP instruction, with the instruction field being added to the program counter to get the new program location. JP has a range from -31 to $+32$ to allow a 1-byte relative jump ($JP + 1$ is implemented by a NOP instruction). There are no “pages” when using JP, since all 15 bits of PC are used.

Absolute

This mode is used with the JMP and JSR instructions, with the instruction field of 12 bits replacing the lower 12 bits of the program counter (PC). This allows jumping to any location in the current 4k program memory segment.

Absolute Long

This mode is used with the JMPL and JSRL instructions, with the instruction field of 15 bits replacing the entire 15 bits of the program counter (PC). This allows jumping to any location in the current 4k program memory space.

Indirect

This mode is used with the JID instruction. The contents of the accumulator are used as a partial address (lower 8 bits of PC) for accessing a location in the program memory. The contents of this program memory location serve as a partial address (lower 8 bits of PC) for the jump to the next instruction.

Note: The VIS is a special case of the Indirect Transfer of Control addressing mode, where the double byte vector associated with the interrupt is transferred from adjacent addresses in the program memory into the program counter (PC) in order to jump to the associated interrupt service routine.

Instruction Set

Register and Symbol Definition

Registers	
A	8-Bit Accumulator Register
B	8-Bit Address Register
X	8-Bit Address Register
SP	8-Bit Stack Pointer Register
PC	15-Bit Program Counter Register
PU	Upper 7 Bits of PC
PL	Lower 8 Bits of PC
C	1 Bit of PSW Register for Carry
HC	1 Bit of PSW Register for Half Carry
GIE	1 Bit of PSW Register for Global Interrupt Enable
VU	Interrupt Vector Upper Byte
VL	Interrupt Vector Lower Byte

Symbols	
[B]	Memory Indirectly Addressed by B Register
[X]	Memory Indirectly Addressed by X Register
MD	Direct Addressed Memory
Mem	Direct Addressed Memory or [B]
Meml	Direct Addressed Memory or [B] or Immediate Data
Imm	8-Bit Immediate Data
Reg	Register Memory: Addresses F0 to FF (Includes B, X and SP)
Bit	Bit Number (0 to 7)
←	Loaded with
↔	Exchanged with

Instruction Set (Continued)

INSTRUCTION SET

ADD	A,Meml	ADD	$A \leftarrow A + \text{Meml}$
ADC	A,Meml	ADD with Carry	$A \leftarrow A + \text{Meml} + C, C \leftarrow \text{Carry}$ $HC \leftarrow \text{Half Carry}$
SUBC	A,Meml	Subtract with Carry	$A \leftarrow A - \text{Meml} + C, C \leftarrow \text{Carry}$ $HC \leftarrow \text{Half Carry}$
AND	A,Meml	Logical AND	$A \leftarrow A \text{ and Meml}$
ANDSZ	A,Imm	Logical AND Immed., Skip if Zero	Skip next if $(A \text{ and Imm}) = 0$
OR	A,Meml	Logical OR	$A \leftarrow A \text{ or Meml}$
XOR	A,Meml	Logical EXclusive OR	$A \leftarrow A \text{ xor Meml}$
IFEQ	MD,Imm	IF Equal	Compare MD and Imm, Do next if $MD = \text{Imm}$
IFEQ	A,Meml	IF Equal	Compare A and Meml, Do next if $A = \text{Meml}$
IFNE	A,Meml	IF Not Equal	Compare A and Meml, Do next if $A \neq \text{Meml}$
IFGT	A,Meml	IF Greater Than	Compare A and Meml, Do next if $A > \text{Meml}$
IFBNE	#	If B Not Equal	Do next if lower 4 bits of B \neq Imm
DRSZ	Reg	Decrement Reg., Skip if Zero	$\text{Reg} \leftarrow \text{Reg} - 1$, Skip if $\text{Reg} = 0$
SBIT	#,Mem	Set BIT	1 to bit, Mem (bit = 0 to 7 immediate)
RBIT	#,Mem	Reset BIT	0 to bit, Mem
IFBIT	#,Mem	IF BIT	If bit in A or Mem is true do next instruction
RPND		Reset PeNDing Flag	Reset Software Interrupt Pending Flag
X	A,Mem	EXchange A with Memory	$A \leftrightarrow \text{Mem}$
X	A,[X]	EXchange A with Memory [X]	$A \leftrightarrow [X]$
LD	A,Meml	LoaD A with Memory	$A \leftarrow \text{Meml}$
LD	A,[X]	LoaD A with Memory [X]	$A \leftarrow [X]$
LD	B,Imm	LoaD B with Immed.	$B \leftarrow \text{Imm}$
LD	Mem,Imm	LoaD Memory Immed	$\text{Mem} \leftarrow \text{Imm}$
LD	Reg,Imm	LoaD Register Memory Immed.	$\text{Reg} \leftarrow \text{Imm}$
X	A, [B ±]	EXchange A with Memory [B]	$A \leftrightarrow [B], (B \leftarrow B \pm 1)$
X	A, [X ±]	EXchange A with Memory [X]	$A \leftrightarrow [X], (X \leftarrow X \pm 1)$
LD	A, [B ±]	LoaD A with Memory [B]	$A \leftarrow [B], (B \leftarrow B \pm 1)$
LD	A, [X ±]	LoaD A with Memory [X]	$A \leftarrow [X], (X \leftarrow X \pm 1)$
LD	[B ±],Imm	LoaD Memory [B] Immed.	$[B] \leftarrow \text{Imm}, (B \leftarrow B \pm 1)$
CLR	A	CLear A	$A \leftarrow 0$
INC	A	INCRement A	$A \leftarrow A + 1$
DEC	A	DECrementA	$A \leftarrow A - 1$
LAID	A	Load A InDirect from ROM	$A \leftarrow \text{ROM (PU,A)}$
DCOR	A	Decimal CORrect A	$A \leftarrow \text{BCD correction of A (follows ADC, SUBC)}$
RRC	A	Rotate A Right thru C	$C \rightarrow A7 \rightarrow \dots \rightarrow A0 \rightarrow C$
RLC	A	Rotate A Left thru C	$C \leftarrow A7 \leftarrow \dots \leftarrow A0 \leftarrow C$
SWAP	A	SWAP nibbles of A	$A7 \dots A4 \leftrightarrow A3 \dots A0$
SC		Set C	$C \leftarrow 1, HC \leftarrow 1$
RC		Reset C	$C \leftarrow 0, HC \leftarrow 0$
IFC		IF C	If C is true, do next instruction
IFNC		IF Not C	If C is not true, do next instruction
POP	A	POP the stack into A	$\text{SP} \leftarrow \text{SP} + 1, A \leftarrow [\text{SP}]$
PUSH	A	PUSH A onto the stack	$[\text{SP}] \leftarrow A, \text{SP} \leftarrow \text{SP} - 1$
VIS		Vector to Interrupt Service Routine	$\text{PU} \leftarrow [\text{VU}], \text{PL} \leftarrow [\text{VL}]$
JMPL	Addr.	Jump absolute Long	$\text{PC} \leftarrow \text{ii} (\text{ii} = 15 \text{ bits}, 0 \text{ to } 32\text{k})$
JMP	Addr.	Jump absolute	$\text{PC9} \dots 0 \leftarrow \text{i} (\text{i} = 12 \text{ bits})$
JP	Disp.	Jump relative short	$\text{PC} \leftarrow \text{PC} + r (r \text{ is } -31 \text{ to } +32, \text{ except } 1)$
JSRL	Addr.	Jump SubRoutine Long	$[\text{SP}] \leftarrow \text{PL}, [\text{SP}-1] \leftarrow \text{PU}, \text{SP} - 2, \text{PC} \leftarrow \text{ii}$
JSR	Addr	Jump SubRoutine	$[\text{SP}] \leftarrow \text{PL}, [\text{SP}-1] \leftarrow \text{PU}, \text{SP} - 2, \text{PC9} \dots 0 \leftarrow \text{i}$
JID		Jump InDirect	$\text{PL} \leftarrow \text{ROM (PU,A)}$
RET		RETurn from subroutine	$\text{SP} + 2, \text{PL} \leftarrow [\text{SP}], \text{PU} \leftarrow [\text{SP}-1]$
RETSK		RETurn and SKip	$\text{SP} + 2, \text{PL} \leftarrow [\text{SP}], \text{PU} \leftarrow [\text{SP}-1]$
RETI		RETurn from Interrupt	$\text{SP} + 2, \text{PL} \leftarrow [\text{SP}], \text{PU} \leftarrow [\text{SP}-1], \text{GIE} \leftarrow 1$
INTR		Generate an Interrupt	$[\text{SP}] \leftarrow \text{PL}, [\text{SP}-1] \leftarrow \text{PU}, \text{SP} - 2, \text{PC} \leftarrow \text{OFF}$
NOP		No OPeration	$\text{PC} \leftarrow \text{PC} + 1$

Instruction Execution Time

Most instructions are single byte (with immediate addressing mode instructions taking two bytes).

Most single byte instructions take one cycle time to execute.

Skipped instructions require x number of cycles to be skipped, where x equals the number of bytes in the skipped instruction opcode.

See the BYTES and CYCLES per INSTRUCTION table for details.

Bytes and Cycles per Instruction

The following table shows the number of bytes and cycles for each instruction in the format of byte/cycle.

Arithmetic and Logic Instructions

	[B]	Direct	Immed.
ADD	1/1	3/4	2/2
ADC	1/1	3/4	2/2
SUBC	1/1	3/4	2/2
AND	1/1	3/4	2/2
OR	1/1	3/4	2/2
XOR	1/1	3/4	2/2
IFEQ	1/1	3/4	2/2
IFNE	1/1	3/4	2/2
IFGT	1/1	3/4	2/2
IFBNE	1/1		
DRSZ		1/3	
SBIT	1/1	3/4	
RBIT	1/1	3/4	
IFBIT	1/1	3/4	

Instructions Using A & C

CLRA	1/1
INCA	1/1
DECA	1/1
LAID	1/3
DCOR	1/1
RRCA	1/1
RLCA	1/1
SWAPA	1/1
SC	1/1
RC	1/1
IFC	1/1
IFNC	1/1
PUSHA	1/3
POPA	1/3
ANDSZ	2/2

Transfer of Control Instructions

JMPL	3/4
JMP	2/3
JP	1/3
JSRL	3/5
JSR	2/5
JID	1/3
VIS	1/5
RET	1/5
RETSK	1/5
RETI	1/5
INTR	1/7
NOP	1/1

RPND	1/1
------	-----

Memory Transfer Instructions

	Register Indirect		Direct	Immed.	Register Indirect Auto Incr. & Decr.	
	[B]	[X]			[B+, B-]	[X+, X-]
X A,*	1/1	1/3	2/3		1/2	1/3
LD A,*	1/1	1/3	2/3	2/2	1/2	1/3
LD B, Imm				1/1		
LD B, Imm				2/2		
LD Mem, Imm	2/2		3/3		2/2	
LD Reg, Imm			2/3			
IFEQ MD, Imm			3/3			

(IF B < 16)
(IF B > 15)

* = > Memory location addressed by B or X or directly.

Opcode Table

Upper Nibble Along X-Axis

Lower Nibble Along Y-Axis

F	E	D	C	B	A	9	8	
JP -15	JP -31	LD 0F0, # i	DRSZ 0F0	RRCA	RC	ADC A, # i	ADC A,[B]	0
JP -14	JP -30	LD 0F1, # i	DRSZ 0F1	*	SC	SUBC A, # i	SUB A,[B]	1
JP -13	JP -29	LD 0F2, # i	DRSZ 0F2	X A, [X+]	X A,[B+]	IFEQ A, # i	IFEQ A,[B]	2
JP -12	JP -28	LD 0F3, # i	DRSZ 0F3	X A, [X-]	X A,[B-]	IFGT A, # i	IFGT A,[B]	3
JP -11	JP -27	LD 0F4, # i	DRSZ 0F4	VIS	LAID	ADD A, # i	ADD A,[B]	4
JP -10	JP -26	LD 0F5, # i	DRSZ 0F5	RPND	JID	AND A, # i	AND A,[B]	5
JP -9	JP -25	LD 0F6, # i	DRSZ 0F6	X A,[X]	X A,[B]	XOR A, # i	XOR A,[B]	6
JP -8	JP -24	LD 0F7, # i	DRSZ 0F7	*	*	OR A, # i	OR A,[B]	7
JP -7	JP -23	LD 0F8, # i	DRSZ 0F8	NOP	RLCA	LD A, # i	IFC	8
JP -6	JP -22	LD 0F9, # i	DRSZ 0F9	IFNE A,[B]	IFEQ Md, # i	IFNE A, # i	IFNC	9
JP -5	JP -21	LD 0FA, # i	DRSZ 0FA	LD A,[X+]	LD A,[B+]	LD [B+], # i	INCA	A
JP -4	JP -20	LD 0FB, # i	DRSZ 0FB	LD A,[X-]	LD A,[B-]	LD [B-], # i	DECA	B
JP -3	JP -19	LD 0FC, # i	DRSZ 0FC	LD Md, # i	JMPL	X A,Md	POPA	C
JP -2	JP -18	LD 0FD, # i	DRSZ 0FD	DIR	JSRL	LD A,Md	RETSK	D
JP -1	JP -17	LD 0FE, # i	DRSZ 0FE	LD A,[X]	LD A,[B]	LD [B], # i	RET	E
JP -0	JP -16	LD 0FF, # i	DRSZ 0FF	*	*	LD B, # i	RETI	F

Opcode Table (Continued)

Upper Nibble Along X-Axis

Lower Nibble Along Y-Axis

7	6	5	4	3	2	1	0	
IFBIT 0,[B]	ANDSZ A, #i	LD B, #0F	IFBNE 0	JSR x000-x0FF	JMP x000-x0FF	JP + 17	INTR	0
IFBIT 1,[B]	*	LD B, #0E	IFBNE 1	JSR x100-x1FF	JMP x100-x1FF	JP + 18	JP + 2	1
IFBIT 2,[B]	*	LD B, #0D	IFBNE 2	JSR x200-x2FF	JMP x200-x2FF	JP + 19	JP + 3	2
IFBIT 3,[B]	*	LD B, #0C	IFBNE 3	JSR x300-x3FF	JMP x300-x3FF	JP + 20	JP + 4	3
IFBIT 4,[B]	CLRA	LD B, #0B	IFBNE 4	JSR x400-x4FF	JMP x400-x4FF	JP + 21	JP + 5	4
IFBIT 5,[B]	SWAPA	LD B, #0A	IFBNE 5	JSR x500-x5FF	JMP x500-x5FF	JP + 22	JP + 6	5
IFBIT 6,[B]	DCORA	LD B, #09	IFBNE 6	JSR x600-x6FF	JMP x600-x6FF	JP + 23	JP + 7	6
IFBIT 7,[B]	PUSHA	LD B, #08	IFBNE 7	JSR x700-x7FF	JMP x700-x7FF	JP + 24	JP + 8	7
SBIT 0,[B]	RBIT 0,[B]	LD B, #07	IFBNE 8	JSR x800-x8FF	JMP x800-x8FF	JP + 25	JP + 9	8
SBIT 1,[B]	RBIT 1,[B]	LD B, #06	IFBNE 9	JSR x900-x9FF	JMP x900-x9FF	JP + 26	JP + 10	9
SBIT 2,[B]	RBIT 2,[B]	LD B, #05	IFBNE 0A	JSR xA00-xAFF	JMP xA00-xAFF	JP + 27	JP + 11	A
SBIT 3,[B]	RBIT 3,[B]	LD B, #04	IFBNE 0B	JSR xB00-xBFF	JMP xB00-xBFF	JP + 28	JP + 12	B
SBIT 4,[B]	RBIT 4,[B]	LD B, #03	IFBNE 0C	JSR xC00-xCFF	JMP xC00-xCFF	JP + 29	JP + 13	C
SBIT 5,[B]	RBIT 5,[B]	LD B, #02	IFBNE 0D	JSR xD00-xDFF	JMP xD00-xDFF	JP + 30	JP + 14	D
SBIT 6,[B]	RBIT 6,[B]	LD B, #01	IFBNE 0E	JSR xE00-xEFF	JMP xE00-xEFF	JP + 31	JP + 15	E
SBIT 7,[B]	RBIT 7,[B]	LD B, #00	IFBNE 0F	JSR xF00-xFFF	JMP xF00-xFFF	JP + 32	JP + 16	F

Where,

i is the immediate data

Md is a directly addressed memory location

* is an unused opcode

Note: The opcode 60 Hex is also the opcode for IFBIT #i,A

Mask Options

The mask programmable options are shown below. The options are programmed at the same time as the ROM pattern submission.

OPTION 1: CLOCK CONFIGURATION

- = 1 Crystal Oscillator (CKI/10)
 - G7 (CKO) is clock generator output to crystal/resonator
 - CKI is the clock input
- = 2 Single-pin RC controlled oscillator (CKI/10)
 - G7 is available as a HALT restart and/or general purpose input

OPTION 2: HALT

- = 1 Enable HALT mode
- = 2 Disable HALT mode

OPTION 3: BONDING OPTIONS

- = 1 44-Pin PLCC
- = 2 40-Pin DIP
- = 3 N/A
- = 4 28-Pin DIP
- = 5 28-Pin S0

Development Support

SUMMARY

- iceMASTER™: IM-COP8/400—Full feature in-circuit emulation for all COP8 products. A full set of COP8 Basic and Feature Family device and package specific probes are available.
- COP8 Debug Module: Moderate cost in-circuit emulation and development programming unit.
- COP8 Evaluation and Programming Unit: EPU-COP888GG—low cost in-circuit simulation and development programming unit.
- Assembler: COP8-DEV-IBMA. A DOS installable cross development Assembler, Linker, Librarian and Utility Software Development Tool Kit.
- C Compiler: COP8C. A DOS installable cross development Software Tool Kit.
- OTP/EPROM Programmer Support: Covering needs from engineering prototype, pilot production to full production environments.

IceMASTER (IM) IN-CIRCUIT EMULATION

The iceMASTER IM-COP8/400 is a full feature, PC based, in-circuit emulation tool development and marketed by MetaLink Corporation to support the whole COP8 family of products. National is a resale vendor for these products.

See *Figure 18* for configuration.

The iceMASTER IM-COP8/400 with its device specific COP8 Probe provides a rich feature set for developing, testing and maintaining product:

- Real-time in-circuit emulation; full 2.4V–5.5V operation range, full DC-10 MHz clock. Chip options are programmable or jumper selectable.
- Direct connection to application board by package compatible socket or surface assembly.
- Full 32 kbyte of loadable programming space that overlays (replaces) the on-chip ROM or EPROM. On-chip RAM and I/O blocks are used directly or recreated on the probe as necessary.
- Full 4k frame synchronous trace memory. Address, instruction, and 8 unspecified, circuit connectable trace lines. Display can be HLL source (e.g., C source), assembly or mixed.

- A full 64k hardware configurable break, trace on, trace off control, and pass count increment events.
- Tool set integrated interactive symbolic debugger—supports both assembler (COFF) and C Compiler (.COD) linked object formats.
- Real time performance profiling analysis; selectable bucket definition.
- Watch windows, content updated automatically at each execution break.
- Instruction by instruction memory/register changes displayed on source window when in single step operation.
- Single base unit and debugger software reconfigurable to support the entire COP8 family; only the probe personality needs to change. Debugger software is processor customized, and reconfigured from a master model file.
- Processor specific symbolic display of registers and bit level assignments, configured from master model file.
- Halt/Idle mode notification.
- On-Line HELP customized to specific processor using master model file.
- Includes a copy of COP8-DEV-IBMA assembler and linker SDK.

IM Order Information

Base Unit	
IM-COP8/400-1	iceMASTER Base Unit, 110V Power Supply
IM-COP8/400-2	iceMASTER Base Unit, 220V Power Supply
iceMASTER Probe	
MHW-884EG28DWPC	28 DIP
MHW-888EG40DWPC	40 DIP
MHW-888EG44PWPC	44 PLCC
Adapter for SO Package	
MHW-SOIC28	28 SO

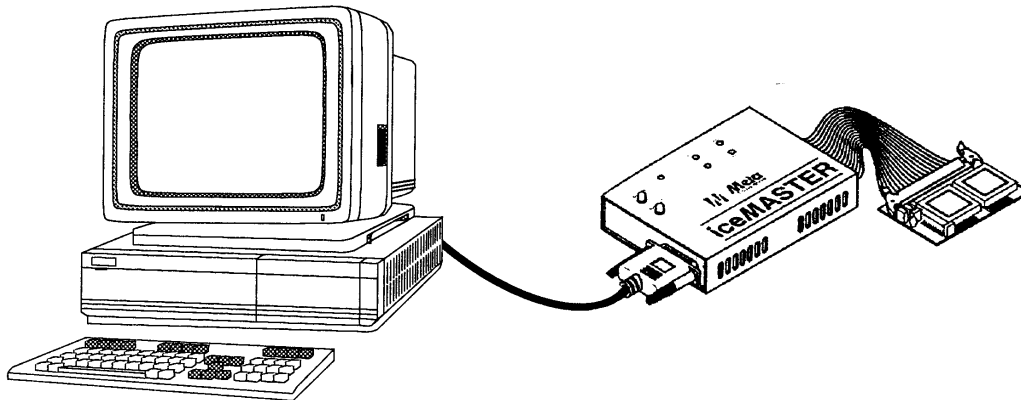

FIGURE 18. COP8 iceMASTER Environment

TL/DD/9765-26

Development Support (Continued)

iceMASTER DEBUG MODULE (DM)

The iceMASTER Debug Module is a PC based, combination in-circuit emulation tool and COP8 based OTP/EPROM programming tool developed and marketed by MetaLink Corporation to support the whole COP8 family of products. National is a resale vendor for these products.

See *Figure 19* for configuration.

The iceMASTER Debug Module is a moderate cost development tool. It has the capability of in-circuit emulation for a specific COP8 microcontroller and in addition serves as a programming tool for COP8 OTP and EPROM product families. Summary of features is as follows:

- Real-time in-circuit emulation; full operating voltage range operation, full DC-10 MHz clock.
- All processor I/O pins can be cabled to an application development board with package compatible cable to socket and surface mount assembly.
- Full 32 kbyte of loadable programming space that overlays (replaces) the on-chip ROM or EPROM. On-chip RAM and I/O blocks are used directly or recreated as necessary.
- 100 frames of synchronous trace memory. The display can be HLL source (C source), assembly or mixed. The most recent history prior to a break is available in the trace memory.
- Configured break points; uses INTR instruction which is modestly intrusive.
- Software-only supported features are selectable.
- Tool set integrated interactive symbolic debugger—supports both assembler (COFF) and C Compiler (.COD) SDK linked object formats.
- Instruction by instruction memory/register changes displayed when in single step operation.

- Debugger software is processor customized, and reconfigured from a master model file.
- Processor specific symbolic display of registers and bit level assignments, configured from master model file.
- Halt/Idle mode notification.
- Programming menu supports full product line of programmable OTP and EPROM COP8 products. Program data is taken directly from the overlay RAM.
- Programming of 44 PLCC and 68 PLCC parts requires external programming adapters.
- Includes wallmount power supply.
- On-board V_{PP} generator from 5V input or connection to external supply supported. Requires V_{PP} level adjustment per the family programming specification (correct level is provided on an on-screen pop-down display).
- On-line HELP customized to specific processor using master model file.
- Includes a copy of COP8-DEV-IBMA assembler and linker SDK.

DM Order Information

Debug Module Unit	
COP8-DM/888GG	
Cable Adapters, Kits for COP888	
DM-COP8/28D	28 DIP
DM-COP8/40D	40 DIP
DM-COP8/44P	44 PLCC
Adapter for SO Package	
MHW-SOIC28	28 SO

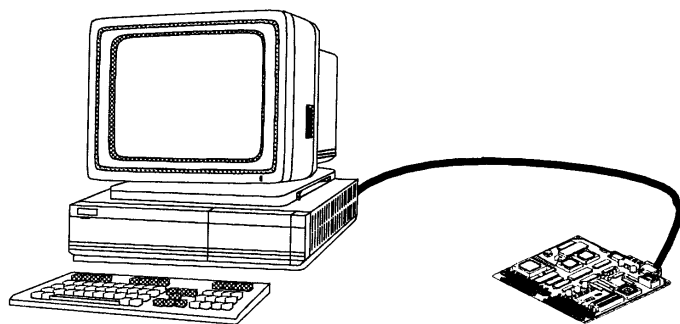

TL/DD/9765-27

FIGURE 19. COP8-DM Environment

Development Support (Continued)

iceMASTER EVALUATION PROGRAMMING UNIT (EPU)

The iceMASTER EPU-COP888GG is a PC based, in-circuit simulation tool to support the feature family COP8 products. See Figure 20 for configuration.

The simulation capability is a very low cost means of evaluating the general COP8 architecture. In addition, the EPU has programming capability, with added adapters, for programming the whole COP8 product family of OTP and EPROM products. The product includes the following features:

- Non-real-time in-circuit simulation. Program overlay memory is PC resident; instructions are downloaded over RS-232 as executed. Approximate performance is 20 kHz.
 - Includes a 40-pin DIP cable adapter. Other target packages are not supported. All processor I/O pins are cabled to the application development environment.
 - Full 32 kbyte of loadable programming space that overlays (replaces) the on-chip ROM or EPROM. On-chip RAM and I/O blocks are used directly or recreated as necessary.
 - On-chip timer and watch-dog execution are not well synchronized to the instruction simulation.
 - 100 frames of synchronous trace memory. The display can be HLL source (e.g., C source), assembly or mixed. The most recent history prior to a break is available in the trace memory.
 - Up to eight software configured break points; uses INTR instruction which is modestly intrusive.
 - Common look-feel debugger software across all Meta-Link products—only supported features are selectable.
- Tool set integrated interactive symbolic debugger—supports both assembler (COFF) and C Compiler (.COD) SDK linked object formats.
 - Instruction by instruction memory/register changes displayed when in single step operation.
 - Processor specific symbolic display of registers and bit level assignments, configured from master model file.
 - Halt/Idle mode notification. Restart requires special handling.
 - Programming menu supports full product line of programmable OTP and EPROM COP8 products. Only a 40 ZIF socket is available on the EPU unit. Adapters are available for other part package configurations.
 - Integral wall mount power supply provides 5V and develops the required V_{pp} to program parts.
 - Includes a copy of COP8-DEV-IBMA assembler, linker SDK.

EPU Order Information

Evaluation Programming Unit	
EPU-COP888GG	Evaluation Programming Unit with debugger and programmer control software with 40 ZIF programming socket.
General Programming Adapters	
COP8-PGMA-DS	28 and 20 DIP and SOIC adapter.
COP8-PGMA-DS44P	28 and 20 DIP and SOIC plus 44 PLCC adapter.

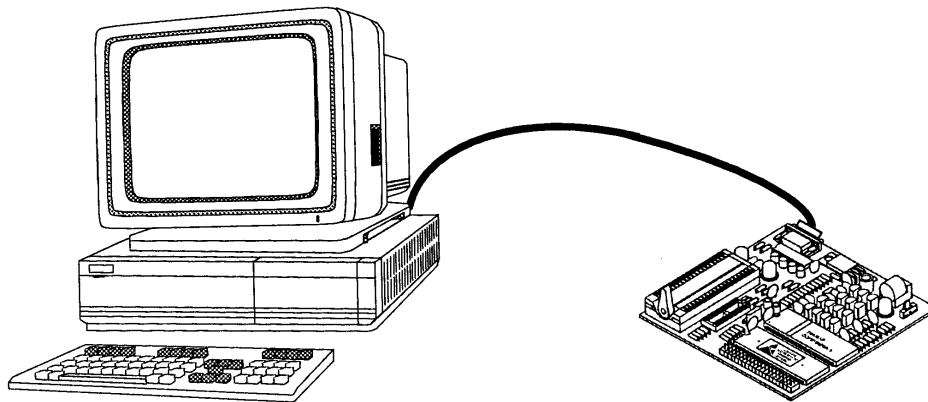

FIGURE 20. EPU-COP8 Tool Environment

TL/DD/9765-28

Development Support (Continued)

COP8 ASSEMBLER/LINKER SOFTWARE DEVELOPMENT TOOL KIT

National Semiconductor offers a relocatable COP8 macro cross assembler, linker, librarian and utility software development tool kit. Features are summarized as follows:

- Basic and Feature Family instruction set by "device" type.
- Nested macro capability.
- Extensive set of assembler directives.
- Supported on PC/DOS platform.
- Generates National standard COFF output files.
- Integrated Linker and Librarian.
- Integrated utilities to generate ROM code file outputs.
- DUMPCOFF utility.

This product is integrated as a part of MetaLink tools as a development kit, fully supported by the MetaLink debugger. It may be ordered separately or it is bundled with the MetaLink products at no additional cost.

Order Information

Assembler SDK	
COP8-DEV-IBMA	Assembler SDK on installable 3.5" PC/DOS Floppy Disk Drive format. Periodic upgrades and most recent version is available on National's BBS and Internet.

COP8 C COMPILER

A C Compiler is developed and marketed by Byte Craft Limited. The COP8C compiler is a fully integrated development tool specifically designed to support the compact embedded configuration of the COP8 family of products.

Features are summarized as follows:

- ANSI C with some restrictions and extensions that optimize development for the COP8 embedded application.
- BITS data type extension. Register declaration #pragma with direct bit level definitions.
- C language support for interrupt routines.
- Expert system, rule based code generation and optimization.
- Performs consistency checks against the architectural definitions of the target COP8 device.
- Generates program memory code.
- Supports linking of compiled object or COP8 assembled object formats.
- Global optimization of linked code.
- Symbolic debug load format fully source level supported by the MetaLink debugger.

SINGLE CHIP OTP/EMULATOR SUPPORT

The COP8 family is supported by single chip OTP emulators. For detailed information refer to the emulator specific datasheet and the emulator selection table below:

Approved List

Manufacturer	North America	Europe	Asia
BP Microsystems	(800) 225-2102 (713) 688-4600 Fax: (713) 688-0920	+ 49-8152-4183 + 49-8856-932616	+ 852-234-16611 + 852-2710-8121
Data I/O	(800) 426-1045 (206) 881-6444 Fax: (206) 882-1043	+ 44-0734-440011	Call North America
HI-LO	(510) 623-8860	Call Asia	+ 886-2-764-0215 Fax: + 886-2-756-6403
ICE Technology	(800) 624-8949 (919) 430-7915	+ 44-1226-767404 Fax: 0-1226-370-434	
MetaLink	(800) 638-2423 (602) 926-0797 Fax: (602) 693-0681	+ 49-80 9156 96-0 Fax: + 49-80 9123 86	+ 852-737-1800
Systems General	(408) 263-6667	+ 41-1-9450300	+ 886-2-917-3005 Fax: + 886-2-911-1283
Needhams	(916) 924-8037 Fax: (916) 924-8065		

Development Support (Continued)

OTP Emulator Ordering Information

Device Number	Clock Option	Package	Emulates
COP87L84EGN-XE	Crystal	28 DIP	COP884CG
COP87L84EGM-XE	Crystal	28 SO	COP884CG
COP87L88EGN-XE	Crystal	40 DIP	COP888CG
COP87L88EGV-XE	Crystal	44 PLCC	COP888CG

INDUSTRY WIDE OTP/EPROM PROGRAMMING SUPPORT

Programming support, in addition to the MetaLink development tools, is provided by a full range of independent approved vendors to meet the needs from the engineering laboratory to full production.

AVAILABLE LITERATURE

For more information, please see the COP8 Basic Family User's Manual, Literature Number 620895, COP8 Feature Family User's Manual, Literature Number 620897 and National's Family of 8-bit Microcontrollers COP8 Selection Guide, Literature Number 630009.

DIAL-A-HELPER SERVICE

Dial-A-Helper is a service provided by the Microcontroller Applications group. The Dial-A-Helper is an Electronic Information System that may be accessed as a Bulletin Board System (BBS) via data modem, as an FTP site on the Internet via standard FTP client application or as an FTP site on the Internet using a standard Internet browser such as Netscape or Mosaic.

The Dial-A-Helper system provides access to an automated information storage and retrieval system. The system capabilities include a MESSAGE SECTION (electronic mail, when accessed as a BBS) for communication to and from the Microcontroller Applications Group and a FILE SECTION which consists of several file areas where valuable application software and utilities could be found.

DIAL-A-HELPER BBS via a Standard Modem

Modem: CANADA/U.S.: (800) NSC-MICRO

(800) 672-6427

EUROPE: (+49) 0-8141-351332

Baud: 14.4k

Set-up: Length: 8-Bit

Parity: None

Stop Bit: 1

Operation: 24 Hours, 7 Days

DIAL-A-HELPER via FTP

ftp nscmicro.nsc.com

user: anonymous

password: username@yourhost.site.domain

DIAL-A-HELPER via a WorldWide Web Browser

ftp://nscmicro.nsc.com

National Semiconductor on the WorldWide Web

See us on the WorldWide Web at: <http://www.national.com>

CUSTOMER RESPONSE CENTER

Complete product information and technical support is available from National's customer response centers.

CANADA/U.S.:	Tel:	(800) 272-9959
	email:	support@tevm2.nsc.com
EUROPE:	email:	europa.support@nsc.com
	Deutsch Tel:	+ 49 (0) 180-530 85 85
	English Tel:	+ 49 (0) 180-532 78 32
	Français Tel:	+ 49 (0) 180-532 93 58
	Italiano Tel:	+ 49 (0) 180-534 16 80
JAPAN:	Tel:	+ 81-043-299-2309
S.E. ASIA:	Beijing Tel:	(+ 86) 10-6856-8601
	Shanghai Tel:	(+ 86) 21
	Hong Kong Tel:	(+ 852) 2737-1600
	Korea Tel:	(+ 82) 2-3771-6909
	Malaysia Tel:	(+ 60-4) 644-9061
	Singapore Tel:	(+ 65) 255-2226
	Taiwan Tel:	+ 886-2-521-3288
AUSTRALIA:	Tel:	(+ 61) 3-9558-9999
INDIA:	Tel:	(+ 91) 80-559-9467

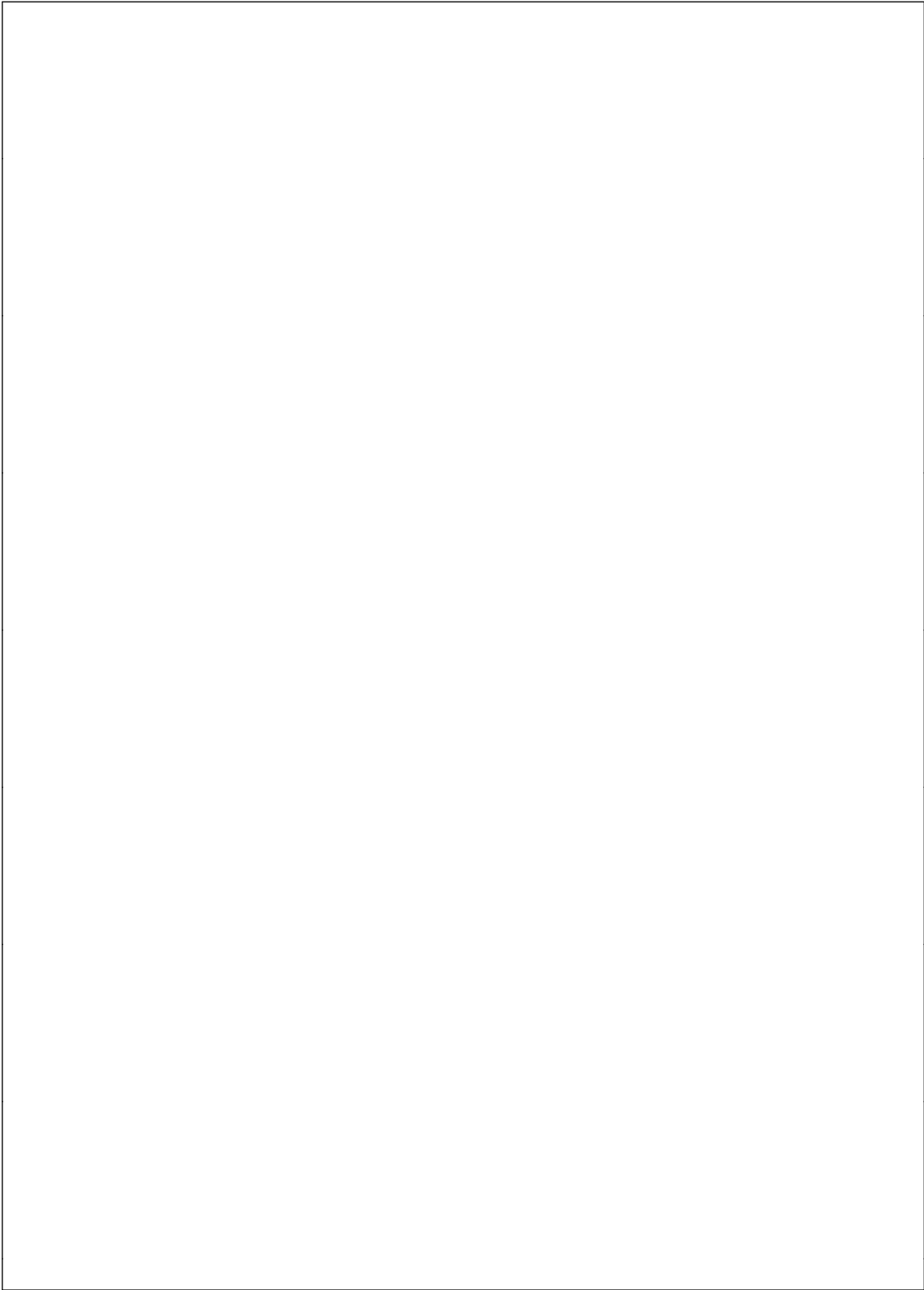

Physical Dimensions inches (millimeters) unless otherwise noted

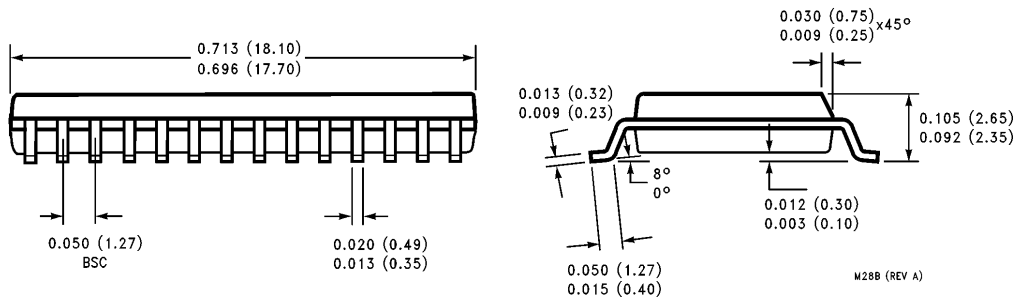
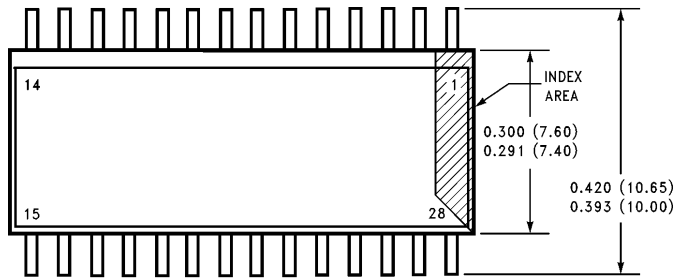

Molded Dual-In-Line Package (N)
Order Number COP884CG-XXX/WM
NS Package Number M28B

M28B (REV A)

Physical Dimensions inches (millimeters) unless otherwise noted (Continued)

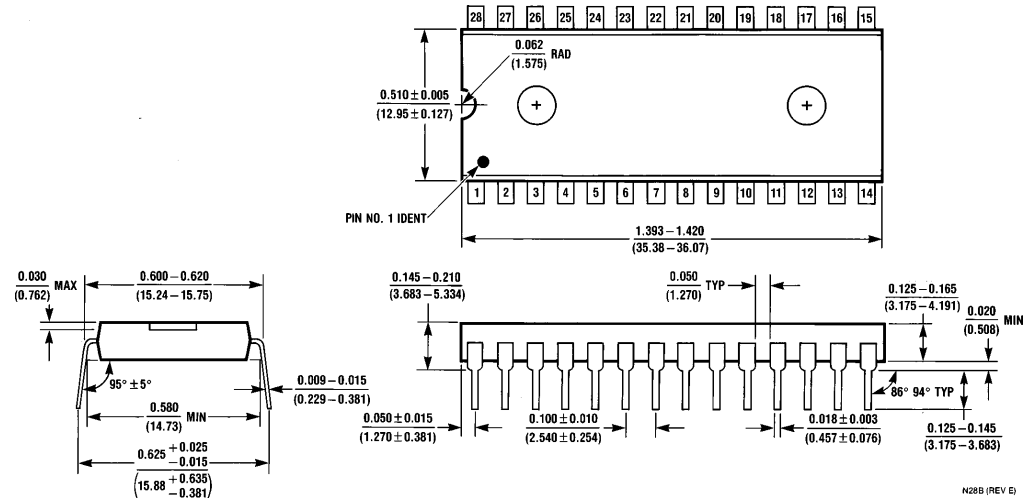

Molded Dual-In-Line Package (N)
Order Number COP884CG-XXX/N
NS Package Number N28B

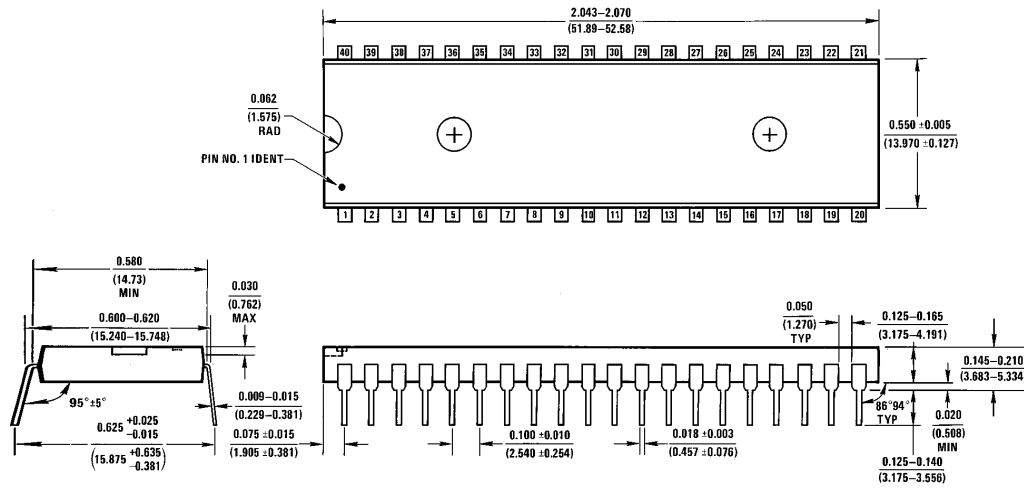

Molded Dual-In-Line Package (N)
Order Number COP888CG-XXX/N
NS Package Number N40A

National Semiconductor was acquired by Texas Instruments.

http://www.ti.com/corp/docs/investor_relations/pr_09_23_2011_national_semiconductor.html

This file is the datasheet for the following electronic components:

COPCG884 - <http://www.ti.com/product/copcg884?HQS=TI-null-null-dscatalog-df-pf-null-wwe>

COP888CG - <http://www.ti.com/product/cop888cg?HQS=TI-null-null-dscatalog-df-pf-null-wwe>

COPCG888 - <http://www.ti.com/product/copcg888?HQS=TI-null-null-dscatalog-df-pf-null-wwe>

COP884CG - <http://www.ti.com/product/cop884cg?HQS=TI-null-null-dscatalog-df-pf-null-wwe>



LittleDiode supplies new, hard to find or obsolete electronic components and semiconductors all over the world.

With over two million different components listed you are sure to find the part you need.

Feel free to visit us today at our online store:

LittleDiode.com

Looking forward to providing you with the best possible service.