

Audio Codec '97 with Headphone Amplifier

Features

- AC '97 2.2 Compliant
- Exceeds the Microsoft® PC 2001 Audio Performance Requirements
- Integrated High-Performance Headphone Amplifier
- On-chip PLL for use with External Clock Sources
- Integrated High-Performance Microphone Pre-Amplifier
- Automatic Jack Sense through GPIO
- BIOS-Driver Interface for Audio Feature Configuration through Software
- S/PDIF Digital Audio Output
- I²S Serial Digital Outputs Enable Cost Effective Six Channel Applications
- Independent Simultaneous S/PDIF and Six Channel Audio Playback
- 20-bit Stereo Digital-to-Analog Converters
- 18-bit Stereo Analog-to-Digital Converters

- Sample Rate Converters
- Three Analog Line-level Stereo Inputs
- High Quality Pseudo-Differential CD Input
- Two Analog Line-level Mono Inputs
- Dual Microphone Inputs
- Stereo and Mono Line-level Outputs
- Extensive Power Management Support

Description

The CS4202 is an AC '97 2.2 compliant stereo audio co-
dec designed for PC multimedia systems. It uses
industry leading delta-sigma and mixed signal technol-
ogy. This advanced technology and these features are
designed to help enable the design of PC 99 and
PC 2001 compliant high-quality audio systems for desk-
top, portable, and entertainment PCs.

Coupling the CS4202 with a PCI audio accelerator or
core logic supporting the AC '97 interface implements a
cost effective, superior quality audio solution. The
CS4202 surpasses PC 99, PC 2001, and AC '97 2.2 au-
dio quality standards.

ORDERING INFO

CS4202-JQ 48-pin TQFP 9x9x1.4 mm

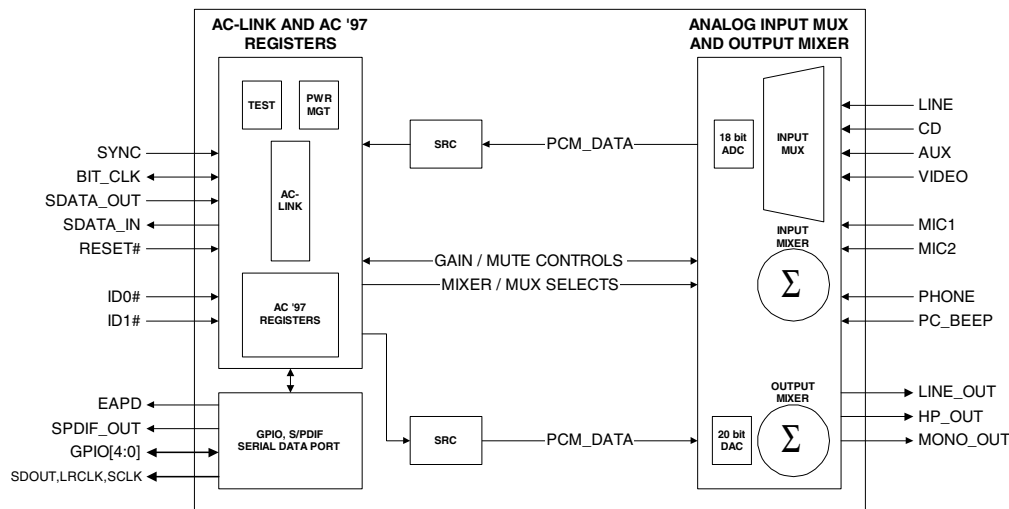

Preliminary Product Information

This document contains information for a new product.
Cirrus Logic reserves the right to modify this product without notice.

TABLE OF CONTENTS

1. CHARACTERISTICS AND SPECIFICATIONS	6
ANALOG CHARACTERISTICS	6
ABSOLUTE MAXIMUM RATINGS	7
RECOMMENDED OPERATING CONDITIONS	7
AC '97 SERIAL PORT TIMING.....	9
2. GENERAL DESCRIPTION	12
2.1 AC-Link	12
2.2 Control Registers	13
2.3 Sample Rate Converters	13
2.4 Mixers	13
2.5 Input Mux	13
2.6 Volume Control	13
3. AC-LINK FRAME DEFINITION	15
3.1 AC-Link Serial Data Output Frame	16
3.1.1 Serial Data Output Slot Tags (Slot 0).....	16
3.1.2 Command Address Port (Slot 1).....	16
3.1.3 Command Data Port (Slot 2).....	17
3.1.4 PCM Playback Data (Slots 3-4,6-11)	17
3.1.5 GPIO Pin Control (Slot12).....	17
3.2 AC-Link Serial Data Input Frame	18
3.2.1 Serial Data Input Slot Tag Bits (Slot 0)	18
3.2.2 Status Address Port (Slot 1)	18
3.2.3 Status Data Port (Slot 2).....	19
3.2.4 PCM Capture Data (Slot 3-4,6-8,11).....	19
3.2.5 GPIO Pin Status (Slot 12)	19
3.3 AC-Link Protocol Violation - Loss of SYNC	20
4. REGISTER INTERFACE	21
4.1 Reset Register (Index 00h)	22
4.2 Analog Mixer Output Volume Registers (Index 02h - 04h)	22
4.3 Mono Volume Register (Index 06h)	23
4.4 PC_BEEP Volume Register (Index 0Ah)	23

Contacting Cirrus Logic Support

For a complete listing of Direct Sales, Distributor, and Sales Representative contacts, visit the Cirrus Logic web site at:
<http://www.cirrus.com/corporate/contacts/sales.cfm>

IMPORTANT NOTICE

"Preliminary" product information describes products that are in production, but for which full characterization data is not yet available. "Advance" product information describes products that are in development and subject to development changes. Cirrus Logic, Inc. and its subsidiaries ("Cirrus") believe that the information contained in this document is accurate and reliable. However, the information is subject to change without notice and is provided "AS IS" without warranty of any kind (express or implied). Customers are advised to obtain the latest version of relevant information to verify, before placing orders, that information being relied on is current and complete. All products are sold subject to the terms and conditions of sale supplied at the time of order acknowledgment, including those pertaining to warranty, patent infringement, and limitation of liability. No responsibility is assumed by Cirrus for the use of this information, including use of this information as the basis for manufacture or sale of any items, or for infringement of patents or other rights of third parties. This document is the property of Cirrus and by furnishing this information, Cirrus grants no license, express or implied under any patents, mask work rights, copyrights, trademarks, trade secrets or other intellectual property rights. Cirrus owns the copyrights of the information contained herein and gives consent for copies to be made of the information only for use within your organization with respect to Cirrus integrated circuits or other parts of Cirrus. This consent does not extend to other copying such as copying for general distribution, advertising or promotional purposes, or for creating any work for resale.

An export permit needs to be obtained from the competent authorities of the Japanese Government if any of the products or technologies described in this material and controlled under the "Foreign Exchange and Foreign Trade Law" is to be exported or taken out of Japan. An export license and/or quota needs to be obtained from the competent authorities of the Chinese Government if any of the products or technologies described in this material is subject to the PRC Foreign Trade Law and is to be exported or taken out of the PRC.

CERTAIN APPLICATIONS USING SEMICONDUCTOR PRODUCTS MAY INVOLVE POTENTIAL RISKS OF DEATH, PERSONAL INJURY, OR SEVERE PROPERTY OR ENVIRONMENTAL DAMAGE ("CRITICAL APPLICATIONS"). CIRRUS PRODUCTS ARE NOT DESIGNED, AUTHORIZED, OR WARRANTED TO BE SUITABLE FOR USE IN LIFE-SUPPORT DEVICES OR SYSTEMS OR OTHER CRITICAL APPLICATIONS. INCLUSION OF CIRRUS PRODUCTS IN SUCH APPLICATIONS IS UNDERSTOOD TO BE FULLY AT THE CUSTOMER'S RISK.

Cirrus Logic, Cirrus, and the Cirrus Logic logo designs are trademarks of Cirrus Logic, Inc. All other brand and product names in this document may be trademarks or service marks of their respective owners.

4.5	Phone Volume Register (Index 0Ch).....	23
4.6	Microphone Volume Register (Index 0Eh).....	24
4.7	Analog Mixer Input Gain Registers (Index 10h - 18h)	25
4.8	Input Mux Select Register (Index 1Ah).....	26
4.9	Record Gain Register (Index 1Ch)	27
4.10	General Purpose Register (Index 20h)	28
4.11	Powerdown Control/Status Register (Index 26h)	29
4.12	Extended Audio ID Register (Index 28h).....	30
4.13	Extended Audio Status/Control Register (Index 2Ah)	31
4.14	Audio Sample Rate Control Registers (Index 2Ch - 32h).....	32
4.15	S/PDIF Control Register (Index 3Ah)	33
4.16	Extended Modem ID Register (Index 3Ch)	34
4.17	Extended Modem Status/Control Register (Index 3Eh)	34
4.18	GPIO Pin Configuration Register (Index 4Ch).....	34
4.19	GPIO Pin Polarity/Type Configuration Register (Index 4Eh).....	35
4.20	GPIO Pin Sticky Register (Index 50h)	35
4.21	GPIO Pin Wakeup Mask Register (Index 52h).....	36
4.22	GPIO Pin Status Register (Index 54h).....	36
4.23	AC Mode Control Register (Index 5Eh)	36
4.24	Misc. Crystal Control Register (Index 60h).....	38
4.25	Serial Port Control Register (Index 6Ah)	39
4.26	BIOS-Driver Interface Control Registers (Index 70h - 72h)	40
4.27	BIOS-Driver Interface Status Register (Index 7Ah).....	40
4.28	Vendor ID1 Register (Index 7Ch)	41
4.29	Vendor ID2 Register (Index 7Eh)	41
5.	SERIAL DATA PORTS	42
5.1	Overview	42
5.2	Multi-Channel Expansion	42
5.3	Serial Data Formats	43
6.	SONY/PHILIPS DIGITAL INTERFACE (S/PDIF)	44
7.	EXCLUSIVE FUNCTIONS	44
8.	POWER MANAGEMENT	45
8.1	AC '97 Reset Modes	45
8.1.1	Cold Reset	45
8.1.2	Warm Reset	45
8.1.3	New Warm Reset	45
8.1.4	Register Reset	45
8.2	Powerdown Controls	46
9.	CLOCKING	48
9.1	PLL Operation (External Clock)	48
9.2	24.576 MHz Crystal Operation	48
9.3	Secondary Codec Operation	48
10.	ANALOG HARDWARE DESCRIPTION	50
10.1	Analog Inputs	50
10.1.1	Line Inputs	50
10.1.2	CD Input	50
10.1.3	Microphone Inputs	50
10.1.4	PC Beep Input	51
10.1.5	Phone Input	51
10.2	Analog Outputs	51
10.2.1	Stereo Outputs	51
10.2.2	Mono Output	52
10.3	Miscellaneous Analog Signals	52
10.4	Power Supplies	52

10.5 Reference Design	53
11. GROUNDING AND LAYOUT	54
12. PIN DESCRIPTIONS	56
13. PARAMETER AND TERM DEFINITIONS	62
14. REFERENCE DESIGN	64
15. REFERENCES	65
16. PACKAGE DIMENSIONS	66

LIST OF FIGURES

Figure 1. Power Up Timing.....	10
Figure 2. Codec Ready from Start-up or Fault Condition	10
Figure 3. Clocks	10
Figure 4. Data Setup and Hold.....	11
Figure 5. PR4 Powerdown and Warm Reset	11
Figure 6. Test Mode	11
Figure 7. AC-link Connections.....	12
Figure 8. CS4202 Mixer Diagram.....	14
Figure 9. AC-link Input and Output Framing.....	15
Figure 10. Serial Data Port: Six Channel Circuit	42
Figure 11. Serial Data Format 0 (I2S)	43
Figure 12. Serial Data Format 1 (Left Justified)	43
Figure 13. Serial Data Format 2 (Right Justified, 20-bit data)	43
Figure 14. Serial Data Format 3 (Right Justified, 16-bit data)	43
Figure 15. S/PDIF Output.....	44
Figure 16. PLL External Loop Filter.....	48
Figure 17. External Crystal.....	49
Figure 18. Line Input (Replicate for Video and AUX)	50
Figure 19. Differential 1 VRMS CD Input	50
Figure 20. Microphone Input	51
Figure 21. PC_BEEP Input.....	51
Figure 22. Modem Connection	51
Figure 23. Line Out and Headphone Out Setup.....	52
Figure 24. Line Out/Headphone Out Setup.....	52
Figure 25. +5V Analog Voltage Regulator.....	53
Figure 26. Conceptual Layout for the CS4202 when in XTAL or OSC Clocking Modes	55
Figure 27. Pin Locations for the CS4202	56
Figure 28. CS4202 Reference Design	64

LIST OF TABLES

Table 1. Register Overview for the CS4202	21
Table 2. Analog Mixer Output Attenuation.....	22
Table 3. Microphone Input Gain Values	24
Table 4. Analog Mixer Input Gain Values	25
Table 5. Analog Mixer Input Gain Register Index.....	25
Table 6. Input Mux Selection	26
Table 7. Record Gain Values	27
Table 8. Slot Mapping for the CS4202	30
Table 9. Slot Assignment Defaults	30
Table 10. Directly Supported SRC Sample Rates for the CS4202.....	32
Table 11. GPIO Input/Output Configurations.....	35
Table 12. Serial Data Format Selection.....	39
Table 13. Device ID with Corresponding Part Number.....	41
Table 14. Serial Data Formats and Compatible DACs for the CS4202.....	43
Table 15. Powerdown PR Bit Functions	46
Table 16. Powerdown PR Function Matrix for the CS4202	47
Table 17. Power Consumption by Powerdown Mode for the CS4202	47
Table 18. Clocking Configurations for the CS4202	49

1. CHARACTERISTICS AND SPECIFICATIONS

ANALOG CHARACTERISTICS

(Standard test conditions unless otherwise noted: $T_{\text{ambient}} = 25^{\circ}\text{C}$, $AV_{\text{dd}} = 5.0\text{V} \pm 5\%$, $DV_{\text{dd}} = 3.3\text{V} \pm 5\%$; 1 kHz Input Sine wave; Sample Frequency, $F_s = 48\text{kHz}$; $Z_{\text{AL}} = 100\text{k}\Omega / 1000\text{pF}$ load for Mono and Line Outputs; $C_{\text{DL}} = 18\text{pF}$ load (Note 1); Measurement bandwidth is 20 Hz - 20 kHz, 18-bit linear coding for ADC functions, 20-bit linear coding for DAC functions; Mixer registers set for unity gain.

Parameter (Note 2)	Symbol	Path (Note 3)	CS4202-JQ			Unit
			Min	Typ	Max	
Full Scale Input Voltage						
Line Inputs		A-D	0.91	1.00	-	V_{RMS}
Mic Inputs (10dB = 0, 20dB = 0)		A-D	0.91	1.00	-	V_{RMS}
Mic Inputs (10dB = 1, 20dB = 0)		A-D	0.283	0.315	-	V_{RMS}
Mic Inputs (10dB = 0, 20dB = 1)		A-D	0.091	0.10	-	V_{RMS}
Mic Inputs (10dB = 1, 20dB = 1)		A-D	0.0283	0.0315	-	V_{RMS}
Full Scale Output Voltage						
Line and Mono Outputs		D-A	0.91	1.0	1.13	V_{RMS}
Headphone Output		D-A	-	1.4	-	V_{RMS}
Frequency Response (Note 4)	FR					
Analog $A_c = \pm 0.25\text{dB}$		A-A	20	-	20,000	Hz
DAC $A_c = \pm 0.25\text{dB}$		D-A	20	-	20,000	Hz
ADC $A_c = \pm 0.25\text{dB}$		A-D	20	-	20,000	Hz
Dynamic Range	DR					
Stereo Analog Inputs to LINE_OUT		A-A	90	95	-	dB FS A
Mono Analog Input to LINE_OUT		A-A	85	90	-	dB FS A
DAC Dynamic Range		D-A	85	90	-	dB FS A
ADC Dynamic Range		A-D	85	90	-	dB FS A
DAC SNR (-20 dB FS input w/ CCIR-RMS filter on output)	SNR	D-A	-	70	-	dB
Total Harmonic Distortion + Noise (-3 dB FS input signal):	THD+N					
Line Output		A-A	-	-90	-80	dB FS
Headphone Output		A-A	-	-75	-70	dB FS
DAC		D-A	-	-87	-80	dB FS
ADC (all inputs)		A-D	-	-84	-80	dB FS
Power Supply Rejection Ratio (1 kHz, $0.5 V_{\text{RMS}}$ w/ 5 V DC offset) (Note 4)			40	60	-	dB
Interchannel Isolation			70	87	-	dB
Spurious Tone (Note 4)			-	-100	-	dB FS
Input Impedance (Note 4)			10	-	-	k Ω

- Notes:
- Z_{AL} refers to the analog output pin loading and C_{DL} refers to the digital output pin loading.
 - Parameter definitions are given in Section 13, *Parameter and Term Definitions*.
 - Path refers to the signal path used to generate this data. These paths are defined in Section 13, *Parameter and Term Definitions*.
 - This specification is guaranteed by silicon characterization; it is not production tested.

ANALOG CHARACTERISTICS (Continued)

Parameter (Note 2)	Symbol	Path (Note 3)	CS4202-JQ			Unit
			Min	Typ	Max	
External Load Impedance						
Line Output, Mono Output			10	-	-	k Ω
Headphone Output			32	-	-	Ω
Output Impedance						
Line Output, Mono Output			-	730	-	Ω
Headphone Output (Note 4)			-	0.8	-	Ω
Input Capacitance (Note 4)			-	5	-	pF
Vrefout			2.3	2.4	2.5	V

MIXER CHARACTERISTICS

Parameter	Min	Typ	Max	Unit
Mixer Gain Range Span				
PC Beep	-	45.0	-	dB
Line In, Aux, CD, Video, Mic1, Mic2, Phone	-	46.5	-	dB
Mono Out, Line Out, Headphone Out	-	46.5	-	dB
ADC Gain	-	22.5	-	dB
Step Size				
All volume controls except PC Beep	-	1.5	-	dB
PC Beep	-	3.0	-	dB

ABSOLUTE MAXIMUM RATINGS (AVss1 = AVss2 = DVss1 = DVss2 = 0 V)

Parameter	Min	Typ	Max	Unit
Power Supplies				
+3.3 V Digital	-0.3	-	5.5	V
+5 V Digital	-0.3	-	5.5	V
Analog	-0.3	-	5.5	V
Total Power Dissipation (Supplies, Inputs, Outputs)	-	-	1.25	W
Input Current per Pin (Except Supply Pins)	-10	-	10	mA
Output Current per Pin (Except Supply Pins)	-15	-	15	mA
Analog Input voltage	-0.3	-	AVdd+ 0.3	V
Digital Input voltage	-0.3	-	DVdd + 0.3	V
Ambient Temperature (Power Applied)	0	-	70	°C
Storage Temperature	-65	-	150	°C

RECOMMENDED OPERATING CONDITIONS (AVss1 = AVss2 = DVss1 = DVss2 = 0 V)

Parameter	Symbol	Min	Typ	Max	Unit
Power Supplies					
+3.3 V Digital	DVdd1, DVdd2	3.135	3.3	3.465	V
+5 V Digital	DVdd1, DVdd2	4.75	5	5.25	V
Analog	AVdd1, AVdd2	4.75	5	5.25	V
Operating Ambient Temperature		0	-	70	°C

DIGITAL CHARACTERISTICS ($AV_{ss1} = AV_{ss2} = DV_{ss1} = DV_{ss2} = 0\text{ V}$)

Parameter	Symbol	Min	Typ	Max	Unit
<i>DVdd = 3.3V</i>					
Low level input voltage	V_{il}	-	-	0.80	V
High level input voltage	V_{ih}	2.15	-	-	V
High level output voltage	V_{oh}	3.00	3.25	-	V
Low level output voltage	V_{ol}	-	0.03	0.35	V
Input Leakage Current (AC-link inputs)		-10	-	10	μA
Output Leakage Current (Tri-stated AC-link outputs)		-10	-	10	μA
Output buffer drive current BIT_CLK, SDATA_IN		-	72	-	mA
SPDIF_OUT		-	24	-	mA
EAPD/SCLK, GPIO0/LRCLK, GPIO1/SDOUT, GPIO2, GPIO3, GPIO4/SDO2 (Note 4)		-	4	-	mA
<i>DVdd = 5.0 V</i>					
Low level input voltage	V_{il}	-	-	0.80	V
High level input voltage	V_{ih}	3.25	-	-	V
High level output voltage	V_{oh}	4.50	4.95	-	V
Low level output voltage	V_{ol}	-	0.03	0.35	V
Input Leakage Current (AC-link inputs)		-10	-	10	μA
Output Leakage Current (Tri-stated AC-link outputs)		-10	-	10	μA
Output buffer drive current BIT_CLK, SDATA_IN		-	72	-	mA
SPDIF_OUT		-	24	-	mA
EAPD/SCLK, GPIO0/LRCLK, GPIO1/SDOUT, GPIO2, GPIO3, GPIO4/SDO2 (Note 4)		-	4	-	mA

AC '97 SERIAL PORT TIMING Standard test conditions unless otherwise noted: $T_{\text{ambient}} = 25^{\circ}\text{C}$,
 $AV_{\text{dd}} = 5.0\text{V}$, $DV_{\text{dd}} = 3.3\text{V}$; $C_L = 55\text{pF}$ load.

Parameter	Symbol	Min	Typ	Max	Unit
RESET Timing					
RESET# active low pulse width	$T_{\text{rst_low}}$	1.0	-	-	μs
RESET# inactive to BIT_CLK start-up delay	(XTL mode) (OSC mode) (PLL mode)	-	4.0	-	μs
		-	4.0	-	μs
		-	2.5	-	ms
1st SYNC active to CODEC READY 'set'	T_{sync2crd}	-	62.5	-	μs
Vdd stable to RESET# inactive	$T_{\text{vdd2rst\#}}$	100	-	-	μs
Clocks					
BIT_CLK frequency	F_{clk}	-	12.288	-	MHz
BIT_CLK period	$T_{\text{clk_period}}$	-	81.4	-	ns
BIT_CLK output jitter (depends on XTL_IN source)		-	-	750	ps
BIT_CLK high pulse width	$T_{\text{clk_high}}$	36	40.7	45	ns
BIT_CLK low pulse width	$T_{\text{clk_low}}$	36	40.7	45	ns
SYNC frequency	F_{sync}	-	48	-	kHz
SYNC period	$T_{\text{sync_period}}$	-	20.8	-	μs
SYNC high pulse width	$T_{\text{sync_high}}$	-	1.3	-	μs
SYNC low pulse width	$T_{\text{sync_low}}$	-	19.5	-	μs
Data Setup and Hold					
Output propagation delay from rising edge of BIT_CLK	T_{co}	8	10	12	ns
Input setup time from falling edge of BIT_CLK	T_{isetup}	10	-	-	ns
Input hold time from falling edge of BIT_CLK	T_{ihold}	0	-	-	ns
Input signal rise time	T_{irise}	2	-	6	ns
Input signal fall time	T_{ifall}	2	-	6	ns
Output signal rise time (Note 4)	T_{orise}	2	4	6	ns
Output signal fall time (Note 4)	T_{ofall}	2	4	6	ns
Misc. Timing Parameters					
End of Slot 2 to BIT_CLK, SDATA_IN low (PR4)	$T_{\text{s2_pdown}}$	-	0.285	1.0	μs
SYNC pulse width (PR4) Warm Reset	$T_{\text{sync_pr4}}$	1.0	-	-	μs
SYNC inactive (PR4) to BIT_CLK start-up delay	T_{sync2clk}	162.8	285	-	ns
Setup to trailing edge of RESET# (ATE test mode) (Note 4)	$T_{\text{setup2rst}}$	15	-	-	ns
Rising edge of RESET# to Hi-Z delay (Note 4)	T_{off}	-	-	25	ns

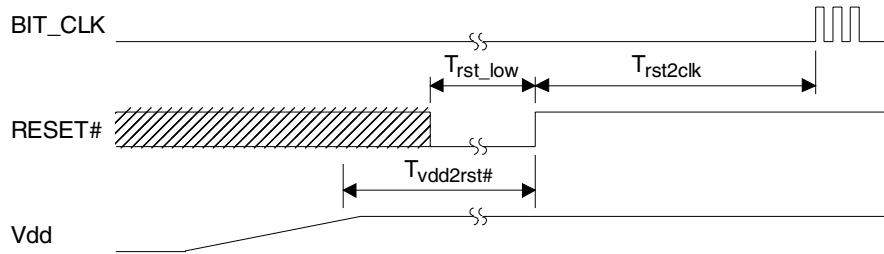

Figure 1. Power Up Timing

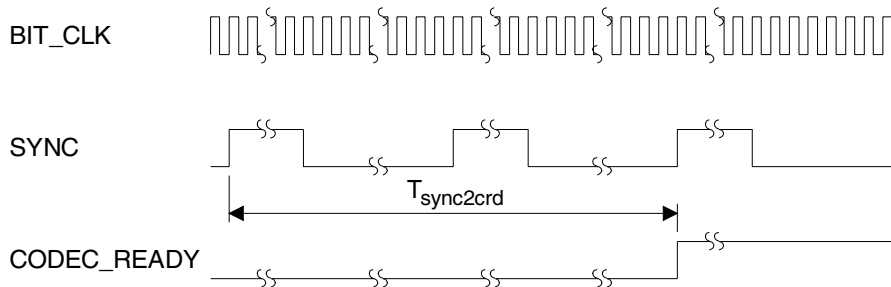

Figure 2. Codec Ready from Start-up or Fault Condition

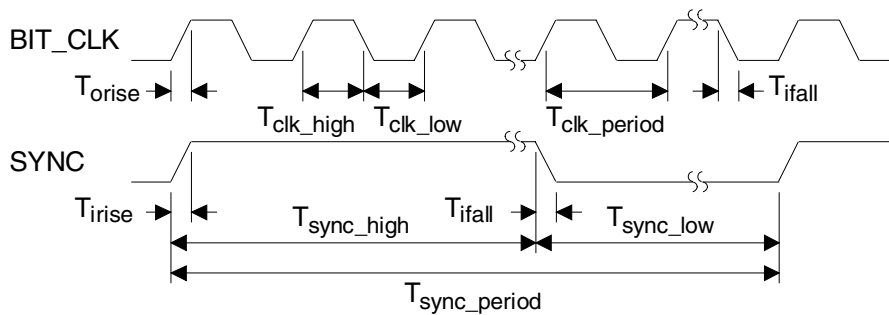

Figure 3. Clocks

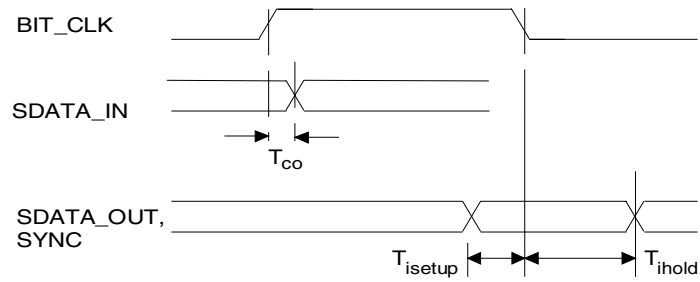

Figure 4. Data Setup and Hold

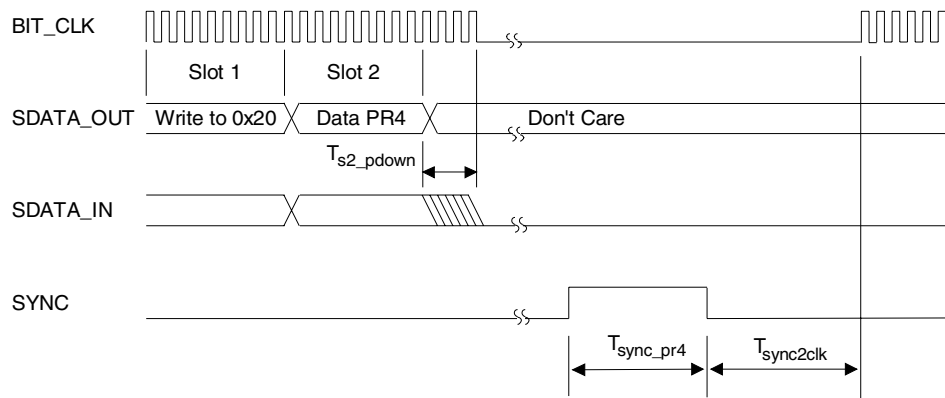

Figure 5. PR4 Powerdown and Warm Reset

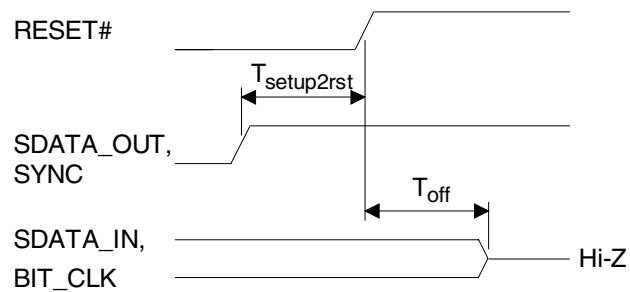

Figure 6. Test Mode

2. GENERAL DESCRIPTION

The CS4202 is a mixed-signal serial audio codec with integrated headphone power amplifier compliant with the Intel® *Audio Codec '97 Specification*, revision 2.2 [6] (referred to as AC '97). It is designed to be paired with a digital controller, typically located on the PCI bus or integrated within the system core logic chip set. The controller is responsible for all communications between the CS4202 and the remainder of the system. The CS4202 contains two distinct functional sections: digital and analog. The digital section includes the AC-link interface, S/PDIF interface, serial data port, GPIO, power management support, and Sample Rate Converters (SRCs). The analog section includes the analog input multiplexer (mux), stereo input mixer, stereo output mixer, mono output mixer, headphone amplifier, stereo Analog-to-Digital Converters (ADCs), stereo Digital-to-Analog Converters (DACs), and their associated volume controls.

2.1 AC-Link

All communication with the CS4202 is established with a 5-wire digital interface to the controller called the AC-link. This interface is shown in Figure 7. All clocking for the serial communication is synchronous to the BIT_CLK signal. BIT_CLK is generated by the primary audio codec and is used to clock the controller and any secondary audio codecs. Both input and output AC-link audio frames are organized as a sequence of 256 serial bits forming 13 groups referred to as 'slots'. During each audio frame, data is passed bi-directionally between the CS4202 and the controller. The input frame is driven from the CS4202 on the SDATA_IN line. The output frame is driven from the controller on the SDATA_OUT line. The controller is also responsible for issuing reset commands via the RESET# signal. Following a Cold Reset, the CS4202 is responsible for notifying the controller that it is ready for operation after synchronizing its internal functions. The CS4202 AC-link signals must use the same digital supply voltage as the controller, either +5 V or +3.3 V. See Section 3, *AC-Link Frame Definition*, for detailed AC-link information.

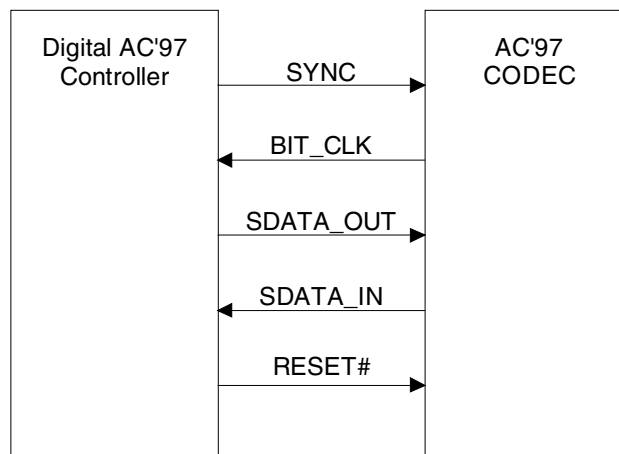

Figure 7. AC-link Connections

2.2 Control Registers

The CS4202 contains a set of AC '97 compliant control registers, and a set of Cirrus Logic defined control registers. These registers control the basic functions and features of the CS4202. Read accesses of the control registers by the AC '97 controller are accomplished with the requested register index in Slot 1 of a SDATA_OUT frame. The following SDATA_IN frame will contain the read data in Slot 2. Write operations are similar, with the register index in Slot 1 and the write data in Slot 2 of a SDATA_OUT frame. The function of each input and output frame is detailed in Section 3, *AC-Link Frame Definition*. Individual register descriptions are found in Section 4, *Register Interface*.

2.3 Sample Rate Converters

The sample rate converters (SRC) provide high accuracy digital filters supporting sample frequencies other than 48 kHz to be captured from the CS4202 or played from the controller. AC '97 requires support for two audio rates (44.1 and 48 kHz). In addition, the Intel® I/O Controller Hub (ICHx) specification [9] requires support for five more audio rates (8, 11.025, 16, 22.05, and 32 kHz). The CS4202 supports all these rates, as shown in Table 10 on page 32.

2.4 Mixers

The CS4202 input and output mixers are illustrated in Figure 8. The stereo input mixer sums together

the analog inputs to the CS4202 according to the settings in the volume control registers. The stereo output mixer sums the output of the stereo input mixer with the PC_BEEP and PHONE signals. The stereo output mix is then sent to the LINE_OUT and HP_OUT pins of the CS4202. The mono output mixer generates a monophonic sum of the left and right audio channels from the stereo input mixer. The mono output mix is then sent to the MONO_OUT pin on the CS4202.

2.5 Input Mux

The input multiplexer controls which analog input is sent to the ADCs. The output of the input mux is converted to stereo 18-bit digital PCM data and transmitted to the controller by means of the AC-link SDATA_IN signal.

2.6 Volume Control

The CS4202 volume registers control analog input levels to the input mixer and analog output levels, including the master volume level. The PC_BEEP volume control uses 3 dB steps with a range of 0 dB to -45 dB attenuation. All other analog volume controls use 1.5 dB steps. The analog inputs have a mixing range of +12 dB signal gain to -34.5 dB signal attenuation. The analog output volume controls have a range of 0 dB to -46.5 dB attenuation for LINE_OUT, HP_OUT and MONO_OUT.

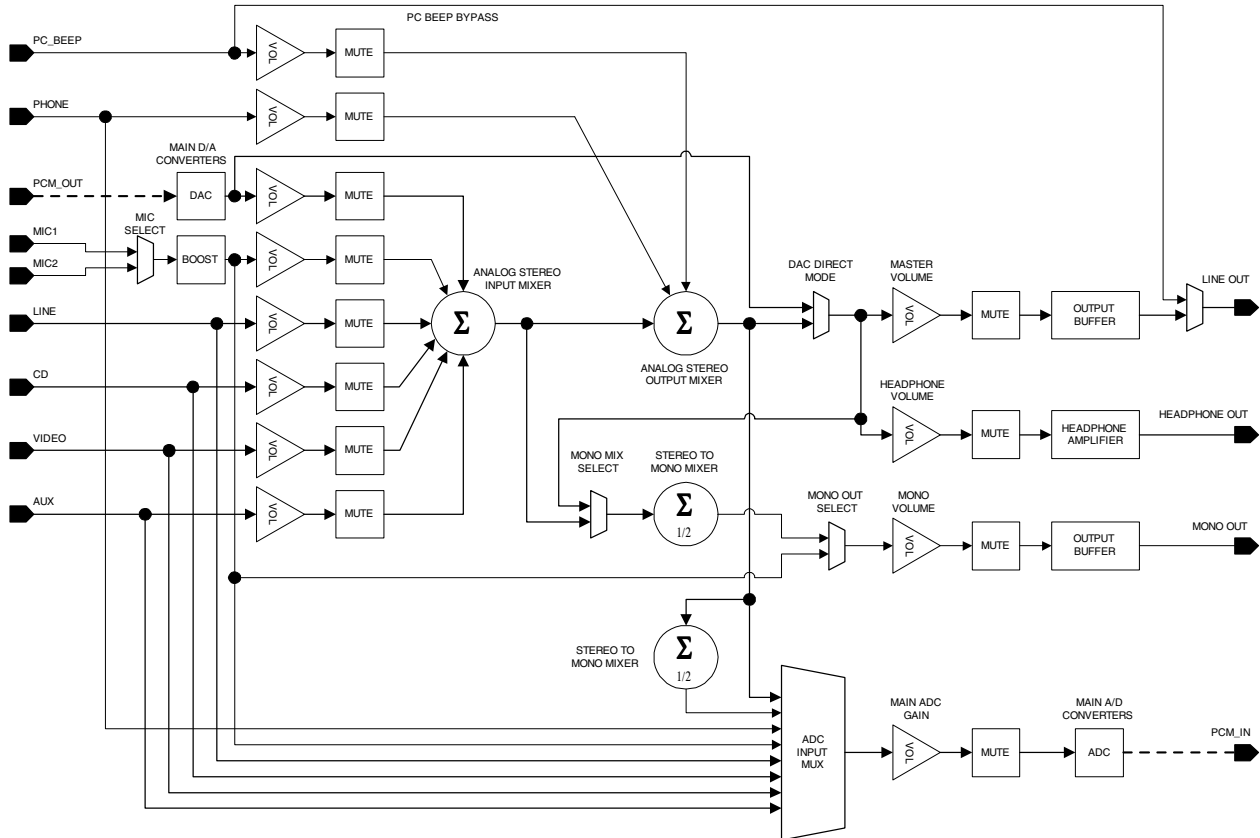

Figure 8. CS4202 Mixer Diagram

3. AC-LINK FRAME DEFINITION

The AC-link is a bi-directional serial port with data organized into frames consisting of one 16-bit and twelve 20-bit time-division multiplexed slots. Slot 0 is a special reserved time slot containing 16-bits which are used for AC-link protocol infrastructure. Slots 1 through 12 contain audio or control/status data. Both the serial data output and input frames are defined from the controller perspective, not from the CS4202 perspective.

The controller synchronizes the beginning of a frame with the assertion of the SYNC signal. Figure 9 shows the position of each bit location

within the frame. The first bit position in a new serial data frame is F0 and the last bit position in the serial data frame is F255. When SYNC goes active (high) and is sampled active by the CS4202 (on the falling edge of BIT_CLK), both devices are synchronized to a new serial data frame. The data on the SDATA_OUT pin at this clock edge is the final bit of the previous frame's serial data. On the next rising edge of BIT_CLK, the first bit of Slot 0 is driven by the controller on the SDATA_OUT pin. On the next falling edge of BIT_CLK, the CS4202 latches this data in as the first bit of the frame.

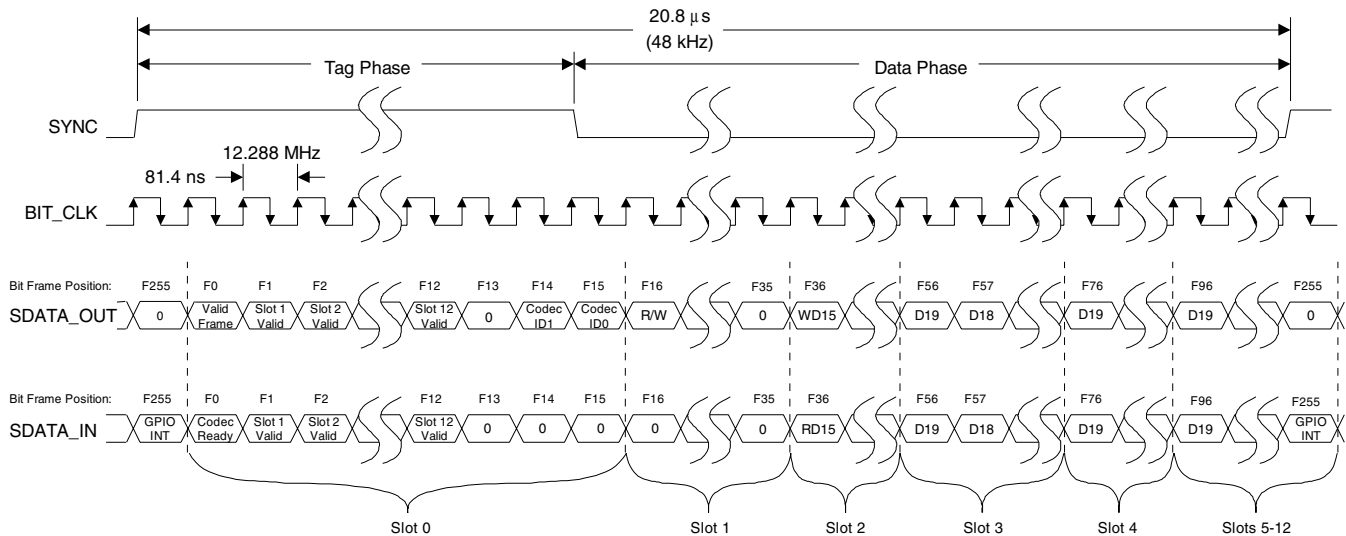

Figure 9. AC-link Input and Output Framing

3.1 AC-Link Serial Data Output Frame

In the serial data output frame, data is passed on the SDATA_OUT pin to the CS4202 from the AC '97 controller. Figure 9 illustrates the serial port timing.

The PCM playback data being passed to the CS4202 is shifted out MSB first in the most significant bits of each slot. Any PCM data from the AC '97 controller that is not 20 bits wide should be left justified in its corresponding slot and dithered or zero-padded in the unused bit positions.

Bits that are reserved should always be 'cleared' by the AC '97 controller.

3.1.1 Serial Data Output Slot Tags (Slot 0)

Bit 15	14	13	12	11	10	9	8	7	6	5	4	3	2	1	0
Valid Frame	Slot 1 Valid	Slot 2 Valid	Slot 3 Valid	Slot 4 Valid	Not Implem	Slot 6 Valid	Slot 7 Valid	Slot 8 Valid	Slot 9 Valid	Slot 10 Valid	Slot 11 Valid	Slot 12 Valid	Res	Codec ID1	Codec ID0

- Valid Frame** The Valid Frame bit determines if any of the following slots contain either valid playback data for the CS4202 or data for read/write operations. When 'set', at least one of the other AC-link slots contains valid data. If this bit is 'clear', the remainder of the frame is ignored.
- Slot 1 Valid** The Slot 1 Valid bit indicates a valid register read/write address for a primary codec.
- Slot 2 Valid** The Slot 2 Valid bit indicates valid register write data for a primary codec.
- Slot [3:4,6:11] Valid** The Slot [3:4,6:11] Valid bits indicate the validity of data in their corresponding serial data output slots. If a bit is 'set', the corresponding output slot contains valid data. If a bit is 'cleared', the corresponding slot will be ignored.
- Slot 12 Valid** The Slot 12 Valid bit indicates if output Slot 12 contains valid GPIO control data.
- Codec ID[1:0]** The Codec ID[1:0] bits determine which codec is being accessed during the current AC-link frame. Codec ID[1:0] = 00 indicates the primary codec is being accessed. Codec ID[1:0] = 01, 10, or 11 indicates one of three possible secondary codecs is being accessed. A Codec ID value of 01, 10, or 11 also indicates a valid read/write address and/or valid register write data for a secondary codec.

3.1.2 Command Address Port (Slot 1)

Bit 19	18	17	16	15	14	13	12	11	10	9	8	7	6	5	4	3	2	1	0
R/W	RI6	RI5	RI4	RI3	RI2	RI1	RI0	Reserved											

- R/W** Read/Write. When this bit is 'set', a read of the AC '97 register specified by the register index bits will occur in the AC '97 2.x audio codec. When the bit is 'cleared', a write will occur. For any read or write access to occur, the Valid Frame bit (F0) must be 'set' and the Codec ID[1:0] bits (F[14:15]) must match the Codec ID of the AC '97 2.x audio codec being accessed. Additionally, for a primary codec, the Slot 1 Valid bit (F1) must be 'set' for a read access and both the Slot 1 Valid bit (F1) and the Slot 2 Valid bit (F2) must be 'set' for a write access. For a secondary codec, both the Slot 1 Valid bit (F1) and the Slot 2 Valid bit (F2) must be 'cleared' for read and write accesses. See Figure 9 for bit frame positions.
- RI[6:0]** Register Index. The RI[6:0] bits contain the 7-bit register index to the AC '97 registers in the CS4202. All registers are defined at word addressable boundaries. The RI0 bit must be 'clear' to access CS4202 registers.

3.1.3 Command Data Port (Slot 2)

Bit 19	18	17	16	15	14	13	12	11	10	9	8	7	6	5	4	3	2	1	0
WD15	WD14	WD13	WD12	WD11	WD10	WD9	WD8	WD7	WD6	WD5	WD4	WD3	WD2	WD1	WD0	Reserved			

WD[15:0] Write Data. The WD[15:0] bits contain the 16-bit value to be written to the register. If an access is a read, this slot is ignored.

NOTE: For any write to an AC '97 register, the write is defined to be an 'atomic' access. This means that when the Slot 1 Valid bit in output Slot 0 is 'set', the Slot 2 Valid bit in output Slot 0 should always be 'set' during the same audio frame. No write access may be split across 2 frames.

3.1.4 PCM Playback Data (Slots 3-4,6-11)

Bit 19	18	17	16	15	14	13	12	11	10	9	8	7	6	5	4	3	2	1	0
PD19	PD18	PD17	PD16	PD15	PD14	PD13	PD12	PD11	PD10	PD9	PD8	PD7	PD6	PD5	PD4	PD3	PD2	PD1	PD0

PD[19:0] Playback Data. The PD[19:0] bits contain the 20-bit PCM (2's complement) playback data for the left and right DACs, serial data ports, and/or the S/PDIF transmitter. Table 8 on page 30 lists a cross reference for each function and its respective slot. The mapping of a given slot to the DAC, serial data port, or S/PDIF transmitter is determined by the state of the DSA[1:0] bits in the *Extended Audio ID Register (Index 28h)* and the SPSA[1:0] bits in the *Extended Audio Status/Control Register (Index 2Ah)*.

3.1.5 GPIO Pin Control (Slot12)

Bit 19	18	17	16	15	14	13	12	11	10	9	8	7	6	5	4	3	2	1	0
Not Implemented											GPIO4	GPIO3	GPIO2	GPIO1	GPIO0	Reserved			

GPIO[4:0] GPIO Pin Control. The GPIO[4:0] bits control the CS4202 GPIO pins configured as outputs. Write accesses using GPIO pin control bits configured as outputs will be reflected on the GPIO pin output on the next AC-link frame. Write accesses using GPIO pin control bits configured as inputs will have no effect and are ignored. If the GPOC bit in the *Misc. Crystal Control Register (Index 60h)* is 'set', the bits in output Slot 12 are ignored and GPIO pins configured as outputs are controlled through the *GPIO Pin Status Register (Index 54h)*.

3.2 AC-Link Serial Data Input Frame

In the serial data input frame, data is passed on the SDATA_IN pin from the CS4202 to the AC '97 controller. The data format for the input frame is very similar to the output frame. Figure 9 on page 15 illustrates the serial port timing.

The PCM capture data from the CS4202 is shifted out MSB first in the most significant 18 bits of each slot. The least significant 2 bits in each slot will be 'cleared'. If the host requests PCM data from the AC '97 Controller that is less than 18 bits wide, the controller should dither and round or just round (but not truncate) to the desired bit depth.

Bits that are reserved or not implemented in the CS4202 will always be returned 'cleared'.

3.2.1 Serial Data Input Slot Tag Bits (Slot 0)

Bit 15	14	13	12	11	10	9	8	7	6	5	4	3	2	1	0
Codec Ready	Slot 1 Valid	Slot 2 Valid	Slot 3 Valid	Slot 4 Valid	0	Slot 6 Valid	Slot 7 Valid	Slot 8 Valid	0	0	Slot 11 Valid	Slot 12 Valid	Reserved		

Codec Ready Codec Ready. The Codec Ready bit indicates the readiness of the CS4202 AC-link. Immediately after a Cold Reset this bit will be 'clear'. Once the CS4202 clocks and voltages are stable, this bit will be 'set'. Until the Codec Ready bit is 'set', no AC-link transactions should be attempted by the controller. The Codec Ready bit does not indicate readiness of the DACs, ADCs, Vref, or any other analog function. Those must be checked in the *Powerdown Control/Status Register (Index 26h)* by the controller before any access is made to the mixer registers. Any accesses to the CS4202 while Codec Ready is 'clear' are ignored.

Slot 1 Valid The Slot 1 Valid bit indicates Slot 1 contains a valid read back address.

Slot 2 Valid The Slot 2 Valid bit indicates Slot 2 contains valid register read data.

Slot [3:4,6:8,11] Valid The Slot [3:4,6:8,11] Valid bits indicate Slot [3:4,6:8,11] contains valid capture data from the CS4202 ADCs. If a bit is 'set', the corresponding input slot contains valid data. If a bit is 'cleared', the corresponding slot will be ignored.

Slot 12 Valid The Slot 12 Valid bit indicates Slot 12 contains valid GPIO status data.

3.2.2 Status Address Port (Slot 1)

Bit 19	18	17	16	15	14	13	12	11	10	9	8	7	6	5	4	3	2	1	0
Res	RI6	RI5	RI4	RI3	RI2	RI1	RI0	SR3	SR4	0	SR6	SR7	SR8	SR9	SR10	SR11	0	Reserved	

RI[6:0] Register Index. The RI[6:0] bits echo the AC '97 register address when a register read has been requested in the previous frame. The CS4202 will only echo the register index for a read access. Write accesses will not return valid data in Slot 1.

SR[3:4,6:11] Slot Request. If SRx is 'set', this indicates the CS4202 SRC does not need a new sample on the next AC-link frame for that particular slot. If SRx is 'clear', the SRC indicates a new sample is needed on the following frame. If the VRA bit in the *Extended Audio Status/Control Register (Index 2Ah)* is 'clear', the SR[3:4,6:11] bits are always 0. When VRA is 'set', the SRC is enabled and the SR[3:4,6:11] bits are used to request data.

3.2.3 Status Data Port (Slot 2)

Bit 19	18	17	16	15	14	13	12	11	10	9	8	7	6	5	4	3	2	1	0
RD15	RD14	RD13	RD12	RD11	RD10	RD9	RD8	RD7	RD6	RD5	RD4	RD3	RD2	RD1	RD0	Reserved			

RD[15:0] Read Data. The RD[15:0] bits contain the register data requested by the controller from the previous read request. All read requests will return the read address in the input Slot 1 and the register data in the input Slot 2 on the following serial data frame.

3.2.4 PCM Capture Data (Slot 3-4,6-8,11)

Bit 19	18	17	16	15	14	13	12	11	10	9	8	7	6	5	4	3	2	1	0
CD17	CD16	CD15	CD14	CD13	CD12	CD11	CD10	CD9	CD8	CD7	CD6	CD5	CD4	CD3	CD2	CD1	CD0	0	0

CD[17:0] Capture Data. The CD [17:0] bits contain 18-bit PCM (2's complement) capture data. The data will only be valid when the respective slot valid bit is 'set' in input Slot 0. The mapping of a given slot to an ADC is determined by the state of the ASA[1:0] bits in the *AC Mode Control Register (index 5Eh)*. The definition of each slot can be found in Table 8 on page 30.

3.2.5 GPIO Pin Status (Slot 12)

Bit 19	18	17	16	15	14	13	12	11	10	9	8	7	6	5	4	3	2	1	0
0	0	0	0	0	0	0	0	0	0	0	GPIO4	GPIO3	GPIO2	GPIO1	GPIO0	Res	BDI	Res	GPIO_INT

GPIO[4:0] GPIO Pin Status. The GPIO[4:0] bits reflect the status of the CS4202 GPIO pins configured as inputs. The pin status of GPIO pins configured as outputs will be reflected back on the GPIO[4:0] bits of input Slot 12 in the next frame. The output GPIO pins are controlled by the GPIO[4:0] pin control bits in output Slot 12.

BDI BIOS-Driver Interface. The BDI bit indicates that a BIOS event has occurred. This bit is a logic OR of all bits in the *BDI Status Register (Index 7Ah)* ANDed with their corresponding bit in the *BDI Config Register (Index 70h)*.

GPIO_INT GPIO Interrupt. The GPIO_INT bit indicates that a GPIO or BDI interrupt event has occurred. The occurrence of a GPIO interrupt is determined by the GPIO interrupt requirements as outlined in the *GPIO Pin Wakeup Mask Register (Index 52h)* description. In this case, the GPIO_INT bit is cleared by writing a '0' to the bit in the *GPIO Pin Status Register (Index 54h)* corresponding to the GPIO pin which generated the interrupt.

The occurrence of a BDI interrupt is determined by the BDI interrupt requirements as outlined in the *BDI Control Registers (Index 70h - 72h)*. In this case, the GPIO_INT bit is cleared by writing a '0' to the bit in the *BDI Status Register (Index 7Ah)* that generated the interrupt.

3.3 AC-Link Protocol Violation - Loss of SYNC

The CS4202 is designed to handle SYNC protocol violations. The following are situations where the SYNC protocol has been violated:

- The SYNC signal is not sampled high for exactly 16 BIT_CLK clock cycles at the start of an audio frame.
- The SYNC signal is not sampled high on the 256th BIT_CLK clock period after the previous SYNC assertion.

- The SYNC signal goes active high before the 256th BIT_CLK clock period after the previous SYNC assertion.

Upon loss of synchronization with the controller, the CS4202 will 'clear' the Codec Ready bit in the serial data input frame until two valid frames are detected. During this detection period, the CS4202 will ignore all register reads and writes and will discontinue the transmission of PCM capture data. In addition, if the LOSM bit in the *Misc. Crystal Control Register (Index 60h)* is 'set' (default), the CS4202 will mute all analog outputs. If the LOSM bit is 'clear', the analog outputs will not be muted.

4. REGISTER INTERFACE

Reg	Register Name	D15	D14	D13	D12	D11	D10	D9	D8	D7	D6	D5	D4	D3	D2	D1	D0	Default	
00h	Reset	0	0	0	0	0	0	0	ID8	ID7	0	0	ID4	0	0	0	0	0190h	
02h	Master Volume	Mute	0	<u>ML5</u>	ML4	ML3	ML2	ML1	ML0	0	0	<u>MR5</u>	MR4	MR3	MR2	MR1	MR0	8000h	
04h	Headphone Volume	Mute	0	<u>ML5</u>	ML4	ML3	ML2	ML1	ML0	0	0	<u>MR5</u>	MR4	MR3	MR2	MR1	MR0	8000h	
06h	Mono Volume	Mute	0	0	0	0	0	0	0	0	0	<u>MM5</u>	MM4	MM3	MM2	MM1	MM0	8000h	
0Ah	PC_BEEP Volume	Mute	0	0	0	0	0	0	0	0	0	0	PV3	PV2	PV1	PV0	0	0000h	
0Ch	Phone Volume	Mute	0	0	0	0	0	0	0	0	0	0	GN4	GN3	GN2	GN1	GN0	8008h	
0Eh	Mic Volume	Mute	0	0	0	0	0	0	0	0	20dB	0	GN4	GN3	GN2	GN1	GN0	8008h	
10h	Line In Volume	Mute	0	0	GL4	GL3	GL2	GL1	GL0	0	0	0	GR4	GR3	GR2	GR1	GR0	8808h	
12h	CD Volume	Mute	0	0	GL4	GL3	GL2	GL1	GL0	0	0	0	GR4	GR3	GR2	GR1	GR0	8808h	
14h	Video Volume	Mute	0	0	GL4	GL3	GL2	GL1	GL0	0	0	0	GR4	GR3	GR2	GR1	GR0	8808h	
16h	Aux Volume	Mute	0	0	GL4	GL3	GL2	GL1	GL0	0	0	0	GR4	GR3	GR2	GR1	GR0	8808h	
18h	PCM Out Volume	Mute	0	0	GL4	GL3	GL2	GL1	GL0	0	0	0	GR4	GR3	GR2	GR1	GR0	8808h	
1Ah	Record Select	0	0	0	0	0	SL2	SL1	SL0	0	0	0	0	0	SR2	SR1	SR0	0000h	
1Ch	Record Gain	Mute	0	0	0	GL3	GL2	GL1	GL0	0	0	0	0	GR3	GR2	GR1	GR0	8000h	
20h	General Purpose	0	0	0	0	0	0	MIX	MS	LPBK	0	0	0	0	0	0	0	0000h	
26h	Powerdown Ctrl/Stat	EAPD	PR6	PR5	PR4	PR3	PR2	PR1	PR0	0	0	0	0	REF	ANL	DAC	ADC	000Fh	
28h	Ext'd Audio ID	ID1	ID0	0	0	REV1	REV0	AMAP	0	0	0	0	DSA1	DSA0	0	SPDIF	0	VRA	x605h
2Ah	Ext'd Audio Stat/Ctrl	0	0	0	0	0	SPCV	0	0	0	0	0	SPSA1	SPSA0	0	SPDIF	0	VRA	0410h
2Ch	PCM Front DAC Rate	SR15	SR14	SR13	SR12	SR11	SR10	SR9	SR8	SR7	SR6	SR5	SR4	SR3	SR2	SR1	SR0	BB80h	
32h	PCM L/R ADC Rate	SR15	SR14	SR13	SR12	SR11	SR10	SR9	SR8	SR7	SR6	SR5	SR4	SR3	SR2	SR1	SR0	BB80h	
3Ah	S/PDIF Control	V	DRS	SPSR1	SPSR0	L	CC6	CC5	CC4	CC3	CC2	CC1	CC0	PRE	COPY	/AUDIO	PRO	2000h	
3Ch	Ext'd Modem ID	ID1	ID0	0	0	0	0	0	0	0	0	0	0	0	0	0	0	0	x000h
3Eh	Ext'd Modem Stat/Ctrl	0	0	0	0	0	0	0	PRA	0	0	0	0	0	0	0	0	GPIO	0100h
4Ch	GPIO Pin Config.	0	0	0	0	0	0	0	0	0	0	0	GC4	GC3	GC2	GC1	GC0	001Fh	
4Eh	GPIO Pin Polarity/Type	1	1	1	1	1	1	1	1	1	1	1	GP4	GP3	GP2	GP1	GP0	FFFFh	
50h	GPIO Pin Sticky	0	0	0	0	0	0	0	0	0	0	0	GS4	GS3	GS2	GS1	GS0	0000h	
52h	GPIO Pin Wakeup	0	0	0	0	0	0	0	0	0	0	0	GW4	GW3	GW2	GW1	GW0	0000h	
54h	GPIO Pin Status	0	0	0	0	0	0	0	0	0	0	0	GI4	GI3	GI2	GI1	GI0	0000h	
Cirrus Logic Defined Registers:																			
5Eh	AC Mode Control	0	0	0	0	ASPM	0	TMM	DDM	0	0	0	ASA1	ASA0	0	0	0	0	0000h
60h	Misc. Crystal Control	0	0	0	DPC	0	0	Reserved	10dB	CRST	0	0	GPOC	Reserved	Reserved	Reserved	LOSM	0003h	
6Ah	Serial Port Control	SDEN	0	0	0	0	0	0	0	0	0	0	0	SDO2	SDSC	SDF1	SDF0	0000h	
70h	BDI Config	E15	E14	E13	E12	E11	E10	E9	E8	E7	E6	E5	E4	E3	E2	E1	E0	0000h	
72h	BDI Wakeup	E15	E14	E13	E12	E11	E10	E9	E8	E7	E6	E5	E4	E3	E2	E1	E0	0000h	
7Ah	BDI Status	E15	E14	E13	E12	E11	E10	E9	E8	E7	E6	E5	E4	E3	E2	E1	E0	0000h	
7Ch	Vendor ID1	F7	F6	F5	F4	F3	F2	F1	F0	S7	S6	S5	S4	S3	S2	S1	S0	4352h	
7Eh	Vendor ID2	T7	T6	T5	T4	T3	T2	T1	T0	0	DID2	DID1	DID0	0	REV2	REV1	REV0	5971h	

Table 1. Register Overview for the CS4202

4.1 Reset Register (Index 00h)

D15	D14	D13	D12	D11	D10	D9	D8	D7	D6	D5	D4	D3	D2	D1	D0
0	0	0	0	0	0	0	ID8	ID7	0	0	ID4	0	0	0	0

- ID8 18-bit ADC Resolution. The ID8 bit is 'set', indicating this feature is present.
- ID7 20-bit DAC resolution. The ID7 bit is 'set', indicating this feature is present.
- ID4 Headphone Out. The ID4 bit is 'set', indicating this feature is present. The state of this bit depends on the state of the HPCFG pin.
- Default 0190h. The data in this register is read-only data.

Any write to this register causes a Register Reset of the audio control (*Index 00h - 3Ah*) and Cirrus Logic defined (*Index 5Ah - 7Ah*) registers. A read from this register returns configuration information about the CS4202.

4.2 Analog Mixer Output Volume Registers (Index 02h - 04h)

D15	D14	D13	D12	D11	D10	D9	D8	D7	D6	D5	D4	D3	D2	D1	D0
Mute	0	<u>ML5</u>	ML4	ML3	ML2	ML1	ML0	0	0	<u>MR5</u>	MR4	MR3	MR2	MR1	MR0

- Mute Output Mute. Setting this bit mutes the LINE_OUT_L/R or HP_OUT_L/R output signals.
- ML[5:0] Output Volume Left. These bits control the left output volume. Each step corresponds to 1.5 dB gain adjustment, with a total available range from 0 dB to -46.5 dB attenuation. Setting the ML5 bit sets the left channel attenuation to -46.5 dB by forcing ML[4:0] to a '1' state. ML[5:0] will read back 011111 when ML5 has been 'set'. See Table 2 for further details.
- MR[5:0] Output Volume Right. These bits control the right output volume. Each step corresponds to 1.5 dB gain adjustment, with a total available range from 0 dB to -46.5 dB attenuation. Setting the MR5 bit sets the right channel attenuation to -46.5 dB by forcing MR[4:0] to a '1' state. MR[5:0] will read back 011111 when MR5 has been 'set'. See Table 2 for further details.
- Default 8000h. This value corresponds to 0 dB attenuation and Mute 'set'.

If the HPCFG pin is left floating, register 02h controls the Master Output Volume and register 04h controls the Headphone Output Volume. If the HPCFG pin is tied 'low', register 02h controls the Headphone Volume and register 04h is a read-only register and always returns 0000h when 'read'.

Mx5 - Mx0 Write	Mx5 - Mx0 Read	Gain Level
000000	000000	0 dB
000001	000001	-1.5 dB
...
011111	011111	-46.5 dB
100000	011111	-46.5 dB
...
111111	011111	-46.5 dB

Table 2. Analog Mixer Output Attenuation

4.3 Mono Volume Register (Index 06h)

D15	D14	D13	D12	D11	D10	D9	D8	D7	D6	D5	D4	D3	D2	D1	D0
Mute	0	0	0	0	0	0	0	0	0	<u>MM5</u>	MM4	MM3	MM2	MM1	MM0

Mute Mono Mute. Setting this bit mutes the MONO_OUT output signal.

MM[5:0] Mono Volume Control. The MM[5:0] bits control the mono output volume. Each step corresponds to 1.5 dB gain adjustment, with a total available range from 0 dB to -46.5 dB attenuation. Setting the MM5 bit sets the mono attenuation to -46.5 dB by forcing MM[4:0] to a '1' state. MM[5:0] will read back 011111 when MM5 has been 'set'. See Table 2 on page 22 for further attenuation levels.

Default 8000h. This value corresponds to 0 dB attenuation and Mute 'set'.

4.4 PC_BEEP Volume Register (Index 0Ah)

D15	D14	D13	D12	D11	D10	D9	D8	D7	D6	D5	D4	D3	D2	D1	D0
Mute	0	0	0	0	0	0	0	0	0	0	PV3	PV2	PV1	PV0	0

Mute PC_BEEP Mute. Setting this bit mutes the PC_BEEP input signal.

PV[3:0] PC_BEEP Volume Control. The PV[3:0] bits control the gain levels of the PC_BEEP input source to the Input Mixer. Each step corresponds to 3 dB gain adjustment, with 0000 = 0 dB. The total range is 0 dB to -45 dB attenuation.

Default 0000h. This value corresponds to 0 dB attenuation and Mute 'clear'.

This register has no effect on the PC_BEEP volume during RESET#.

4.5 Phone Volume Register (Index 0Ch)

D15	D14	D13	D12	D11	D10	D9	D8	D7	D6	D5	D4	D3	D2	D1	D0
Mute	0	0	0	0	0	0	0	0	0	0	GN4	GN3	GN2	GN1	GN0

Mute Phone Mute. Setting this bit mutes the Phone input signal.

GN[5:0] Phone Volume Control. The GN[4:0] bits control the gain level of the Phone input source to the Input Mixer. Each step corresponds to 1.5 dB gain adjustment, with 01000 = 0 dB. The total range is +12 dB to -34.5 dB attenuation. See Table 4 on page 25 for further attenuation levels.

Default 8008h. This value corresponds to 0 dB attenuation and Mute 'set'.

4.6 Microphone Volume Register (Index 0Eh)

D15	D14	D13	D12	D11	D10	D9	D8	D7	D6	D5	D4	D3	D2	D1	D0
Mute	0	0	0	0	0	0	0	0	20dB	0	GN4	GN3	GN2	GN1	GN0

- Mute** Microphone Mute. Setting this bit mutes the MIC1 or MIC2 signal. The selection of the MIC1 or MIC2 input pin is controlled by the MS bit in the *General Purpose Register (Index 20h)*.
- 20dB** Microphone 20 dB Boost. When 'set', the 20dB bit enables the +20 dB microphone boost block. In combination with the 10dB boost bit in the *Misc. Crystal Control Register (Index 60h)* this bit allows for variable boost from 0 dB to +30 dB in steps of 10 dB. Table 3 summarizes this behavior.
- GN[4:0]** Microphone Volume Control. The GN[4:0] bits are used to control the gain level of the Microphone input source to the Input Mixer. Each step corresponds to 1.5 dB gain adjustment, with 01000 = 0 dB. The total range is +12 dB to -34.5 dB gain. See Table 3 for further details.
- Default** 8008h. This value corresponds to 0 dB gain and Mute 'set'.

GN4 - GN0	Gain Level			
	10dB = 0, 20dB = 0	10dB = 1, 20dB = 0	10dB = 0, 20dB = 1	10dB = 1, 20dB = 1
00000	+12.0 dB	+22.0 dB	+32.0 dB	+42.0 dB
00001	+10.5 dB	+20.5 dB	+30.5 dB	+40.5 dB
...
00111	+1.5 dB	+11.5 dB	+21.5 dB	+31.5 dB
01000	0.0 dB	+10.0 dB	+20.0 dB	+30.0 dB
01001	-1.5 dB	+8.5 dB	+18.5 dB	+28.5 dB
...
11111	-34.5 dB	-24.5 dB	-14.5 dB	-4.5 dB

Table 3. Microphone Input Gain Values

4.7 Analog Mixer Input Gain Registers (Index 10h - 18h)

D15	D14	D13	D12	D11	D10	D9	D8	D7	D6	D5	D4	D3	D2	D1	D0
Mute	0	0	GL4	GL3	GL2	GL1	GL0	0	0	0	GR4	GR3	GR2	GR1	GR0

Mute Stereo Input Mute. Setting this bit mutes the respective input signal, both right and left inputs.

GL[4:0] Left Volume Control. The GL[4:0] bits are used to control the gain level of the left analog input source to the Input Mixer. Each step corresponds to 1.5 dB gain adjustment, with 01000 = 0 dB. The total range is +12 dB to -34.5 dB gain. See Table 4 for further details.

GR[4:0] Right Volume Control. The GR[4:0] bits are used to control the gain level of the right analog input source to the Input Mixer. Each step corresponds to 1.5 dB gain adjustment, with 01000 = 0 dB. The total range is +12 dB to -34.5 dB gain. See Table 4 for further details.

Default 8808h. This value corresponds to 0 dB gain and Mute 'set'.

The Analog Mixer Input Gain Registers are listed in Table 5.

Gx4 - Gx0	Gain Level
00000	+12.0 dB
00001	+10.5 dB
...	...
00111	+1.5 dB
01000	0.0 dB
01001	-1.5 dB
...	...
11111	-34.5 dB

Table 4. Analog Mixer Input Gain Values

Register Index	Function
10h	Line In Volume
12h	CD Volume
14h	Video Volume
16h	Aux Volume
18h	PCM Out Volume

Table 5. Analog Mixer Input Gain Register Index

4.8 Input Mux Select Register (Index 1Ah)

D15	D14	D13	D12	D11	D10	D9	D8	D7	D6	D5	D4	D3	D2	D1	D0
0	0	0	0	0	SL2	SL1	SL0	0	0	0	0	0	SR2	SR1	SR0

SL[2:0] Left Channel Source. The SL[2:0] bits select the left channel source to pass to the ADCs for recording. See Table 6 for possible values.

SR[2:0] Right Channel Source. The SR[2:0] bits select the right channel source to pass to the ADCs for recording. See Table 6 for possible values.

Default 0000h. This value selects the Mic input for both channels.

Sx2 - Sx0	Record Source
000	Mic
001	CD Input
010	Video Input
011	Aux Input
100	Line Input
101	Stereo Mix
110	Mono Mix
111	Phone Input

Table 6. Input Mux Selection

4.9 Record Gain Register (Index 1Ch)

D15	D14	D13	D12	D11	D10	D9	D8	D7	D6	D5	D4	D3	D2	D1	D0
Mute	0	0	0	GL3	GL2	GL1	GL0	0	0	0	0	GR3	GR2	GR1	GR0

- Mute** Record Gain Mute. Setting this bit mutes the input to the L/R ADCs.
- GL[3:0]** Left ADC Gain. The GL[3:0] bits control the input gain on the left channel of the analog source, applied after the input mux and before the ADCs. Each step corresponds to 1.5 dB gain adjustment, with 0000 = 0 dB. The total range is 0 dB to +22.5 dB gain. See Table 7 for further details.
- GR[3:0]** Right ADC Gain. The GR[3:0] bits control the input gain on the right channel of the analog source, applied after the input mux and before the ADCs. Each step corresponds to 1.5 dB gain adjustment, with 0000 = 0 dB. The total range is 0 dB to +22.5 dB gain. See Table 7 for further details.
- Default** 8000h. This value corresponds to 0 dB gain and Mute 'set'.

Gx3 - Gx0	Gain Level
1111	+22.5 dB
...	...
0001	+1.5 dB
0000	0 dB

Table 7. Record Gain Values

4.10 General Purpose Register (Index 20h)

D15	D14	D13	D12	D11	D10	D9	D8	D7	D6	D5	D4	D3	D2	D1	D0
0	0	0	0	0	0	MIX	MS	LPBK	0	0	0	0	0	0	0

- MIX** Mono Output Path. This bit controls the source of the mono output driver. When 'clear', the output of the stereo-to-mono mixer is sent to the mono output. When 'set', the output of the microphone boost stage is sent to the mono output. The source of the stereo-to-mono mixer is controlled by the TMM bit in the *AC Mode Control Register (Index 5Eh)*. The source of the microphone boost stage is controlled by the MS bit in the *General Purpose Register (Index 20h)*.
- MS** Microphone Select. The MS bit determines which of the two Mic inputs are passed to the mixer. When 'set', the MIC2 input is selected. When 'clear', the MIC1 input is selected.
- LPBK** Loopback Enable. When 'set', the LPBK bit enables the ADC/DAC Loopback Mode. This bit routes the output of the ADCs to the input of the DACs without involving the AC-link.
- Default** 0000h

4.11 Powerdown Control/Status Register (Index 26h)

D15	D14	D13	D12	D11	D10	D9	D8	D7	D6	D5	D4	D3	D2	D1	D0
EAPD	PR6	PR5	PR4	PR3	PR2	PR1	PR0	0	0	0	0	REF	ANL	DAC	ADC

EAPD	External Amplifier Power Down. The EAPD pin follows this bit and is generally used to power down external amplifiers. The EAPD bit is mutually exclusive with the SDSC bit in the <i>Serial Port Control Register (Index 6Ah)</i> . The SDSC bit must be 'clear' before the EAPD bit may be 'set'. If the SDSC bit is 'set', EAPD is a read-only bit and always returns '0'.
PR6	Headphone Amplifier Powerdown. When 'set', the headphone amplifier is powered down.
PR5	Internal Clock Disable. When 'set', the internal master clock is disabled (BIT_CLK running). The only way to recover from setting this bit is through a Cold Reset (driving the RESET# signal active).
PR4	AC-link Powerdown. When 'set', the AC-link is powered down (BIT_CLK off). The AC-link can be restarted through a Warm Reset using the SYNC signal, or a Cold Reset using the RESET# signal (primary audio codec only).
PR3	Analog Mixer Powerdown (Vref off). When 'set', the analog mixer and voltage reference are powered down. When clearing this bit, the ANL, ADC, and DAC bits should be checked before writing any mixer registers.
PR2	Analog Mixer Powerdown (Vref on). When 'set', the analog mixer is powered down (the voltage reference is still active). When clearing this bit, the ANL bit should be checked before writing any mixer registers.
PR1	Front DACs Powerdown. When 'set', the DACs are powered down. When clearing this bit, the DAC bit should be checked before sending any data to the DACs.
PR0	L/R ADCs and Input Mux Powerdown. When 'set', the ADCs and the ADC input muxes are powered down. When clearing this bit, no valid data will be sent down the AC-link until the ADC bit goes high.
REF	Voltage Reference Ready Status. When 'set', the REF bit indicates the voltage reference is at a nominal level.
ANL	Analog Ready Status. When 'set', the analog output mixer, input multiplexer, and volume controls are ready. When 'clear', no volume control registers should be written.
DAC	Front DAC Ready Status. When 'set', the DACs are ready to receive data across the AC-link. When 'clear', the DACs will not accept any valid data.
ADC	L/R ADCs Ready Status. When 'set', the ADCs are ready to send data across the AC-link. When 'clear', no data will be sent to the controller.
Default	000Fh. This value indicates all blocks are powered on. The lower four bits will change as the CS4202 finishes an initialization and calibration sequence.

The PR[6:0] and the EAPD bits are powerdown control for different sections of the CS4202 as well as external amplifiers. The REF, ANL, DAC, and ADC bits are read-only status bits which, when 'set', indicate that a particular section of the CS4202 is ready. After the controller receives the Codec Ready bit in input Slot 0, these status bits must be checked before writing to any mixer registers. See Section 8, *Power Management*, for more information on the powerdown functions.

4.12 Extended Audio ID Register (Index 28h)

D15	D14	D13	D12	D11	D10	D9	D8	D7	D6	D5	D4	D3	D2	D1	D0
ID1	ID0	0	0	REV1	REV0	AMAP	0	0	0	DSA1	DSA0	0	SPDIF	0	VRA

ID[1:0] Codec ID. These bits indicate the current codec configuration. When ID[1:0] = 00, the CS4202 is the primary audio codec. When ID[1:0] = 01, 10, or 11, the CS4202 is a secondary audio codec. The state of the ID[1:0] bits is determined at power-up from the ID[1:0]# pins and the current clocking scheme, see Table 18 on page 49.

REV[1:0] AC '97 Revision. The REV[1:0] bits indicate which version of the AC '97 specification the codec complies with. These bits always return '01', indicating the CS4202 complies with version 2.2 of the AC '97 specification.

AMAP Audio Slot Mapping. The AMAP bit indicates whether the AC '97 2.2 compliant AC-link slot to audio DAC mapping is supported. This bit always returns '1', indicating that audio slot mapping is supported. The PCM playback and capture slots are mapped according to Table 8 on page 30.

Slot Assignment		Slot Mapping									
DSA1 SPSA1 ASA1	DSA0 SPSA0 ASA0	DAC		SDOUT		SDO2		S/PDIF		ADC	
		L	R	L	R	L	R	L	R	L	R
0	0	3	4	7	8	6	9	3	4	3	4
0	1	7	8	6	9	10	11	7	8	7	8
1	0	6	9	10	11	-	-	6	9	6	11
1	1	10	11	-	-	-	-	10	11	-	-

Table 8. Slot Mapping for the CS4202

DSA[1:0] DAC Slot Assignment. The DSA[1:0] bits control the mapping of output slots to the DAC/SRC block as well as the serial data port. To satisfy AC '97 2.2 AMAP requirements, the default for these bits will depend on the Codec ID as shown in Table 9. See Table 8 for all available Slot Map settings.

Codec ID	DSA[1:0] default	SPSA[1:0] default	ASA[1:0] default
0	00	01	00
1	01	10	00
2	01	10	00
3	10	11	00

Table 9. Slot Assignment Defaults

SPDIF Sony/Philips Digital Interface. The SPDIF bit is 'set', indicating that the optional S/PDIF transmitter is supported.

VRA Variable Rate PCM Audio. The VRA bit indicates whether variable rate PCM audio is supported. This bit always returns '1', indicating that variable rate PCM audio is available.

Default x605h. The *Extended Audio ID Register (Index 28h)* is a read-only register, except for the DSA[1:0] bits which are read/write.

4.13 Extended Audio Status/Control Register (Index 2Ah)

D15	D14	D13	D12	D11	D10	D9	D8	D7	D6	D5	D4	D3	D2	D1	D0
0	0	0	0	0	SPCV	0	0	0	0	SPSA1	SPSA0	0	SPDIF	0	VRA

- SPCV** S/PDIF Configuration Valid. This read-only bit indicates the status of the S/PDIF transmitter subsystem, enabling the driver to determine if the currently programmed S/PDIF configuration is supported. SPCV is always valid, independent of the S/PDIF enable bit status.
- SPSA[1:0]** S/PDIF Slot Assignment. These bits control the mapping of output slots to the S/PDIF transmitter. To satisfy AC '97 2.2 AMAP requirements, the default for these bits will depend on the Codec ID as shown in Table 9 on page 30. See Table 8 on page 30 for all available Slot Map settings.
- SPDIF** Enable Sony/Philips Digital Interface. This bit enables S/PDIF data transmission on the SPDIF_OUT pin. The SPDIF bit routes the left and right channel data from the AC '97 controller or from the ADC output to the S/PDIF transmitter block. The actual data routed to the S/PDIF block are controlled through the configuration of the SPSA[1:0] bits and the ASPM bit in the *AC Mode Control Register (Index 5Eh)*.
- VRA** Enable Variable Rate Audio. When 'set', the VRA bit allows access to the *PCM Front DAC Rate Register (Index 2Ch)* and the *PCM L/R ADC Rate Register (Index 32h)*. This bit must be 'set' in order to use variable PCM playback or capture rates. The VRA bit also serves as a powerdown for the DAC and ADC SRC blocks. Clearing VRA will reset the *PCM Front DAC Rate Register (Index 2Ch)* and the *PCM L/R ADC Rate Register (Index 32h)* to their default values. The SRC data path is flushed and the Slot Request bits for the currently active DAC slots will be fixed at '0'.
- Default** 0410h

4.14 Audio Sample Rate Control Registers (Index 2Ch - 32h)

D15	D14	D13	D12	D11	D10	D9	D8	D7	D6	D5	D4	D3	D2	D1	D0
SR15	SR14	SR13	SR12	SR11	SR10	SR9	SR8	SR7	SR6	SR5	SR4	SR3	SR2	SR1	SR0

SR[15:0] Sample Rate Select. The *Audio Sample Rate Control Registers (Index 2Ch - 32h)* control playback and capture sample rates. The *PCM Front DAC Rate Register (Index 2Ch)* controls the Front Left and Front Right DAC sample rates. The *PCM L/R ADC Rate Register (Index 32h)* controls the Left and Right ADC sample rates. There are seven sample rates directly supported by this register, shown in Table 10. Any value written to this register not contained in Table 10 is not directly supported and will be decoded according to the ranges indicated in the table. The range boundaries have been chosen so that only bits SR[15:12] of each register will have to be considered. All register read transactions will reflect the actual value stored (column 2 in Table 10) and not the one attempted to be written.

Default BB80h. This value corresponds to 48 kHz sample rate.

Writes to the *PCM Front DAC Rate Register (Index 2Ch)* and the *PCM L/R ADC Rate Register (Index 32h)* are only available in Variable Rate PCM Audio mode when the VRA bit in the *Extended Audio Status/Control Register (Index 2Ah)* is 'set'. If VRA = 0, writes to the register are ignored and the register will always read BB80h.

Sample Rate (Hz)	SR[15:0], register content (hex value)	SR[15:0], decode range (hex value)	SR[15:12], decode range (bin value)
8,000	1F40	0000 - 1FFF	0000 - 0001
11,025	2B11	2000 - 2FFF	0010 - 0010
16,000	3E80	3000 - 3FFF	0011 - 0011
22,050	5622	4000 - 5FFF	0100 - 0101
32,000	7D00	6000 - 7FFF	0110 - 0111
44,100	AC44	8000 - AFFF	1000 - 1010
48,000	BB80	B000 - FFFF	1011 - 1111

Table 10. Directly Supported SRC Sample Rates for the CS4202

4.15 S/PDIF Control Register (Index 3Ah)

D15	D14	D13	D12	D11	D10	D9	D8	D7	D6	D5	D4	D3	D2	D1	D0
V	DRS	SPSR1	SPSR0	L	CC6	CC5	CC4	CC3	CC2	CC1	CC0	PRE	COPY	/AUDIO	PRO

V	Validity. The V bit is mapped to the V bit (bit 28) of every <i>sub-frame</i> . If this bit is ‘clear’, the signal is suitable for conversion or processing.
DRS	Double Rate S/PDIF. The DRS bit is mapped to bit 27 of the channel status block. This bit controls support for optional higher sample rate transmission. The CS4202 does not support double rate S/PDIF transmission, therefore DRS is a read-only bit and always returns ‘0’.
SPSR[1:0]	S/PDIF Sample Rate. The SPSR[1:0] bits are mapped to bits 24 and 25 of the channel status block. These bits control the S/PDIF transmitter clock rate. The CS4202 only supports transmission at the standard 48 kHz rate, therefore SPSR[1:0] are read-only bits and always return ‘10’.
L	Generation Status. The L bit is mapped to bit 15 of the channel status block. For category codes 001xxxx, 0111xxx and 100xxxx, a value of ‘0’ indicates original material and a value of ‘1’ indicates a copy of original material. For all other category codes the definition of the L bit is reversed.
CC[6:0]	Category Code. The CC[6:0] bits are mapped to bits 8-14 of the channel status block.
PRE	Data Pre-emphasis. The PRE bit is mapped to bit 3 of the channel status block. If the PRE bit is ‘set’, 50/15 µs filter pre-emphasis is indicated. If the bit is ‘clear’, no pre-emphasis is indicated.
COPY	Copyright. The COPY bit is mapped to bit 2 of the channel status block. If the COPY bit is ‘set’ copyright is not asserted and copying is permitted.
/AUDIO	Audio / Non-Audio. The /AUDIO bit is mapped to bit 1 of the channel status block. If the /AUDIO bit is ‘clear’, the data transmitted over S/PDIF is assumed to be digital audio. If the /AUDIO bit is ‘set’, non-audio data is assumed.
PRO	Professional/Consumer. The PRO bit is mapped to bit 0 of the channel status block. If the PRO bit is ‘clear’, consumer use of the audio control block is indicated. If the bit is ‘set’, professional use is indicated.
Default	2000h

For a further discussion of the proper use of the channel status bits see application note *AN22: Overview of Digital Audio Interface Data Structures [3]*

4.16 Extended Modem ID Register (Index 3Ch)

D15	D14	D13	D12	D11	D10	D9	D8	D7	D6	D5	D4	D3	D2	D1	D0
ID1	ID0	0	0	0	0	0	0	0	0	0	0	0	0	0	0

ID[1:0] Codec ID. These bits indicate the current codec configuration. When ID[1:0] = 00, the CS4202 is the primary audio codec. When ID[1:0] = 01, 10, or 11, the CS4202 is a secondary audio codec. The state of the ID[1:0] bits is determined at power-up from the ID[1:0]# pins and the current clocking scheme, see Table 18 on page 49.

Default x000h. This value indicates no supported modem functions.

The *Extended Modem ID Register (Index 3Ch)* is a read/write register that identifies the CS4202 modem capabilities. Writing any value to this location issues a reset to modem registers (*Index 3Ch-54h*), including GPIO registers (*Index 4Ch - 54h*). Audio registers are not reset by a write to this location.

4.17 Extended Modem Status/Control Register (Index 3Eh)

D15	D14	D13	D12	D11	D10	D9	D8	D7	D6	D5	D4	D3	D2	D1	D0
0	0	0	0	0	0	0	PRA	0	0	0	0	0	0	0	GPIO

PRA GPIO Powerdown. When 'set', the PRA bit powers down the GPIO subsystem. When the GPIO section is powered down, all outputs must be tri-stated and input Slot 12 should be marked invalid when the AC-link is active. To use any GPIO functionality PRA must be cleared first.

GPIO GPIO. When 'set', the GPIO bit indicates the GPIO subsystem is ready for use. When 'set', input Slot 12 will also be marked valid.

Default 0100h

4.18 GPIO Pin Configuration Register (Index 4Ch)

D15	D14	D13	D12	D11	D10	D9	D8	D7	D6	D5	D4	D3	D2	D1	D0
0	0	0	0	0	0	0	0	0	0	0	GC4	GC3	GC2	GC1	GC0

GC[4:0] GPIO Pin Configuration. When 'set', the GC[4:0] bits define the corresponding GPIO pin as an input. When 'clear', the corresponding GPIO pin is defined as an output. When the SDEN bit in the *Serial Port Control Register (Index 6Ah)* is 'set', the GC[1:0] bits are read-only bits and always return '0'. When SDEN is 'clear', the GC[1:0] bits function normally. Likewise, when the SDO2 bit in the *Serial Port Control Register (Index 6Ah)* is 'set', the GC4 bit is a read-only bit and always returns '0'. When SDO2 is 'clear', the GC4 bit functions normally. The GC[3:2] bits have no such dependency.

Default 001Fh. This value corresponds to all GPIO pins configured as inputs.

After a Cold Reset or a modem Register Reset (see *Extended Modem ID Register (Index 3Ch)*), all GPIO pins are configured as inputs. The upper 11 bits of this register always return '0'.

4.19 GPIO Pin Polarity/Type Configuration Register (Index 4Eh)

D15	D14	D13	D12	D11	D10	D9	D8	D7	D6	D5	D4	D3	D2	D1	D0
1	1	1	1	1	1	1	1	1	1	1	GP4	GP3	GP2	GP1	GP0

GP[4:0] GPIO Pin Configuration. This register defines the GPIO input polarity (0 = Active Low, 1 = Active High) when a GPIO pin is configured as an input. The GP[4:0] bits define the GPIO output type (0 = CMOS, 1 = OPEN-DRAIN) when a GPIO pin is configured as an output. The GC[4:0] bits in the *GPIO Pin Configuration Register (Index 4Ch)* define the GPIO pins as inputs or outputs. See Table 11 for the various GPIO configurations.

Default FFFFh

After a Cold Reset or a modem Register Reset this register defaults to all 1's. The upper 11 bits of this register always return '1'.

GCx	GPx	Function	Configuration
0	0	Output	CMOS Drive
0	1	Output	Open Drain
1	0	Input	Active Low
1	1	Input	Active High (default)

Table 11. GPIO Input/Output Configurations

4.20 GPIO Pin Sticky Register (Index 50h)

D15	D14	D13	D12	D11	D10	D9	D8	D7	D6	D5	D4	D3	D2	D1	D0
0	0	0	0	0	0	0	0	0	0	0	GS4	GS3	GS2	GS1	GS0

GS[4:0] GPIO Pin Sticky. This register defines the GPIO input type (0 = not sticky, 1 = sticky) when a GPIO pin is configured as an input. The GPIO pin status of an input configured as "sticky" is 'cleared' by writing a '0' to the corresponding bit of the *GPIO Pin Status Register (Index 54h)*, and by reset.

Default 0000h

After a Cold Reset or a modem Register Reset this register defaults to all 0's, specifying "non-sticky". "Sticky" is defined as edge sensitive, "non-sticky" as level sensitive. The upper 11 bits of this register always return '0'.

4.21 GPIO Pin Wakeup Mask Register (Index 52h)

D15	D14	D13	D12	D11	D10	D9	D8	D7	D6	D5	D4	D3	D2	D1	D0
0	0	0	0	0	0	0	0	0	0	0	GW4	GW3	GW2	GW1	GW0

GW[4:0] GPIO Pin Wakeup. This register provides a mask for determining if an input GPIO change will generate a wakeup event (0 = no, 1 = yes). When the AC-link is powered up, a wakeup event will be communicated through the assertion of GPIO_INT = 1 in input Slot 12. When the AC-link is powered down (*Powerdown Control/Status Register (Index 26h)* bit PR4 = 1 for primary codecs), a wakeup event will be communicated through a '0' to '1' transition on SDATA_IN.

Default 0000h

GPIO bits which have been programmed as inputs, "sticky", and "wakeup", upon transition either (high-to-low) or (low-to-high) depending on pin polarity, will cause an AC-link wakeup if and only if the AC-link was powered down. Once the controller has re-established communication with the CS4202 following a Warm Reset, it will continue to signal the wakeup event through the GPIO_INT bit of input Slot 12 until the AC '97 controller clears the interrupt-causing bit in the *GPIO Pin Status Register (Index 54h)*; or the "wakeup", config, or "sticky" status of that GPIO pin changes.

After a Cold Reset or a modem Register Reset (see *Extended Modem ID Register (Index 3Ch)*) this register defaults to all 0's, specifying no wakeup event. The upper 11 bits of this register always return '0'.

4.22 GPIO Pin Status Register (Index 54h)

D15	D14	D13	D12	D11	D10	D9	D8	D7	D6	D5	D4	D3	D2	D1	D0
0	0	0	0	0	0	0	0	0	0	0	GI4	GI3	GI2	GI1	GI0

GI[4:0] GPIO Pin Status. This register reflects the state of all GPIO pin inputs and outputs. These values are also reflected in Slot 12 of every SDATA_IN frame. GPIO inputs configured as "sticky" are 'cleared' by writing a '0' to the corresponding bit of this register. The GPIO_INT bit in input Slot 12 is 'cleared' by clearing all interrupt-causing bits in this register.

Default 0000h

GPIO pins which have been programmed as inputs and "sticky", upon transition either (high-to-low) or (low-to-high) depending on pin polarity, will cause the individual GI bit to be 'set', and remain 'set' until 'cleared'. GPIO pins which have been programmed as outputs are controlled either through output Slot 12 or through this register, depending on the state of the GPOC bit in the *Misc. Crystal Control Register (Index 60h)*. If the GPOC bit is 'cleared', the GI bits in this register are read-only and reflect the status of the corresponding GPIO output pin 'set' through output slot 12. If the GPOC bit is 'set', the GI bits in this register are read/write bits and control the corresponding GPIO output pins.

The default value is always the state of the GPIO pin. The upper 11 bits of this register should be forced to zero in this register and input Slot 12.

4.23 AC Mode Control Register (Index 5Eh)

D15	D14	D13	D12	D11	D10	D9	D8	D7	D6	D5	D4	D3	D2	D1	D0
0	0	0	0	ASPM	0	TMM	DDM	0	0	ASA1	ASA0	0	0	0	0

ASPM Analog S/PDIF Mode. The ASPM bit controls the input source to the S/PDIF transmitter block. When 'clear', the S/PDIF transmitter will receive data from the corresponding AC-link output slots. The actual slots are determined by the state of the SPSA[1:0] bits in the *Extended Audio Status/Control Register (Index 2Ah)*. If 'set', the S/PDIF transmitter block will receive data

	from the ADC output.
TMM	True Mono Mode. The TMM bit controls the source of the stereo-to-mono mixer that feeds into the mono out select mux. If this bit is 'clear', the output of the stereo input mixer is sent to the stereo-to-mono mixer. If this bit is 'set', the output of the DAC direct mode mux is sent to the stereo-to-mono mixer. This allows a true mono mix that includes the PC Beep and Phone inputs and also works during DAC direct mode.
DDM	DAC Direct Mode. The DDM bit controls the source of the line and headphone output drivers. When this bit is 'clear', the CS4202 stereo output mixer drives the line and headphone outputs. When this bit is 'set', the CS4202 audio DACs (DAC1 and DAC2) directly drive the line and headphone outputs.
ASA[1:0]	ADC Slot Assignment. The ASA[1:0] bits control the mapping of input slots to the ADC/SRC block. The default value of '00' selects input slots 3 and 4. See Table 8 on page 30 for all available Slot Map settings.
Default	0000h

4.24 Misc. Crystal Control Register (Index 60h)

D15	D14	D13	D12	D11	D10	D9	D8	D7	D6	D5	D4	D3	D2	D1	D0
0	0	0	DPC	0	0	Reserved		10dB	CRST	0	0	GPOC	Reserved		LOSM

DPC	DAC Phase Control. This bit controls the phase of the PCM stream sent to the DACs (after SRC). When 'cleared' the phase of the signal will remain unchanged. When this bit is 'set', each PCM sample will be inverted before being sent to the DACs.
10dB	Microphone 10 dB Boost. When 'set', the 10dB bit enables an additional boost of 10 dB on the selected microphone input. In combination with the 20dB boost bit in the <i>Microphone Volume Register (Index 0Eh)</i> this bit allows for variable boost from 0 dB to +30 dB in steps of 10 dB.
CRST	Force Cold Reset. The CRST bit is used as an override to the New Warm Reset behavior defined during PR4 powerdown. If this bit is 'set', an active RESET# signal will force a Cold Reset to the CS4202 during a PR4 powerdown.
GPOC	General Purpose Output Control. The GPOC bit specifies the mechanism by which the status of a General Purpose Output pin can be controlled. If this bit is 'cleared', the GPO status is controlled through the standard AC '97 method of setting the appropriate bits in output Slot 12. If this bit is 'set', the GPO status is controlled through the <i>GPIO Pin Status Register (Index 54h)</i> .
LOSM	Loss of SYNC Mute Enable. The LOSM bit controls the loss of SYNC mute function. If this bit is 'set', the CS4202 will mute all analog outputs for the duration of loss of SYNC. If this bit is 'cleared', the mixer will continue to function normally during loss of SYNC. The CS4202 expects to sample SYNC 'high' for 16 consecutive BIT_CLK periods and then 'low' for 240 consecutive BIT_CLK periods, otherwise loss of SYNC becomes true.
Default	0003h

4.25 Serial Port Control Register (Index 6Ah)

D15	D14	D13	D12	D11	D10	D9	D8	D7	D6	D5	D4	D3	D2	D1	D0
SDEN	0	0	0	0	0	0	0	0	0	0	0	SDO2	SDSC	SDF1	SDF0

SDEN Serial Data Output Enable. The SDEN bit enables transmission of serial data on the SDOUT pin. The SDEN bit routes the left and right channel data from the AC '97 controller to the serial data port. The actual data routed to the serial data port are controlled through the DSA[1:0] configuration in the *Extended Audio ID Register (Index 28h)*. SDEN also functions as a master control for the second serial data output port and the serial clock. Setting this bit also disables the GPIO[1:0] pins and clears the GC[1:0] bits in the *GPIO Pin Configuration Register (Index 4Ch)*. Clearing this bit re-enables the GPIO[1:0] pins and sets the GC[1:0] bits.

SDO2 Serial Data Output 2 Enable. The SDO2 bit enables transmission of serial data on the GPIO4/SDO2 pin. The SDO2 bit routes the left and right channel data from the AC '97 controller to the second serial data port. The actual slots routed to the second serial data port are controlled through the DSA[1:0] configuration in the *Extended Audio ID Register (Index 28h)*. This bit can only be 'set' if the SDEN bit is '1' and will be 'cleared' automatically if SDEN returns to '0'. Setting this bit also disables the GPIO4 pin and clears the GC4 bit in the *GPIO Pin Configuration Register (Index 4Ch)*. Clearing this bit re-enables the GPIO4 pin and sets the GC4 bit.

SDSC Serial Clock Enable. The SDSC bit enables transmission of a serial clock on the EAPD/SCLK pin. Serial data can be routed to DACs that support internal SCLK mode without transmitting a serial clock. For DACs that only support external SCLK mode, transmission of a serial clock is required and this bit must be set to '1'. This bit can only be set if the SDEN bit is '1' and will be cleared automatically if SDEN returns to '0'. Furthermore, the SDSC bit can only be 'set' if the EAPD bit in the *Powerdown Control/Status Register (Index 26h)* is '0'. If the SDEN bit is '0' or the EAPD bit is '1', SDSC is a read-only bit and always returns '0'.

SDF[1:0] Serial Data Format. The SDF[1:0] bits control the format of the serial data transmitted on the two output ports. All ports will use the same format. See Table 12 for available formats.

Default 0000h

SDF1	SDF0	Serial Data Format
0	0	I ² S
0	1	Left Justified
1	0	Right Justified, 20-bit data
1	1	Right Justified, 16-bit data

Table 12. Serial Data Format Selection

4.26 BIOS-Driver Interface Control Registers (Index 70h - 72h)

D15	D14	D13	D12	D11	D10	D9	D8	D7	D6	D5	D4	D3	D2	D1	D0
E15	E14	E13	E12	E11	E10	E9	E8	E7	E6	E5	E4	E3	E2	E1	E0

E[15:0] Event Configuration. The E[15:0] bits control the BIOS-Driver Interface mechanism.

Default 0000h

The *BDI Config Register (Index 70h)* enables BIOS-Driver communication for each possible event. If a bit is '0', the corresponding event will not be communicated. If a bit is '1', the corresponding event will be communicated by asserting the BDI bit in input slot 12. If an event occurs, the BIOS will 'set' the corresponding bit in the *BDI Status Register (Index 7Ah)*. This bit remains 'set' until it is cleared by the driver, acknowledging the event has been handled. This behavior is equivalent to "non-sticky" (level sensitive) GPIO input pins.

The *BDI Wakeup Register (Index 72h)* provides a mask for determining if a BDI event will generate a wakeup or GPIO_INT. If a bit is '0', the corresponding event will not generate an interrupt. If a bit is '1', the corresponding event will generate an interrupt. Refer to the *GPIO Pin Wakeup Mask Register (Index 52h)* for details about wakeup interrupts.

4.27 BIOS-Driver Interface Status Register (Index 7Ah)

D15	D14	D13	D12	D11	D10	D9	D8	D7	D6	D5	D4	D3	D2	D1	D0
E15	E14	E13	E12	E11	E10	E9	E8	E7	E6	E5	E4	E3	E2	E1	E0

E[15:0] Event Status. This register, in conjunction with the *BIOS-Driver Interface Control Registers (Index 70h - 72h)*, controls the BIOS-Driver Interface mechanism.

Default 0000h

The *BDI Status Register (Index 7Ah)* reflects the state of all possible events. If a bit is '0', the corresponding event has not occurred or has already been handled by the driver. If a bit is '1', the corresponding event has occurred and has not been handled by the driver yet. The BDI bit in input slot 12 is a logic OR of all bits in this register ANDed with their corresponding bit in the *BDI Config Register (Index 70h)*. After handling an event, the driver should clear it by writing a '0' to the corresponding bit of this register.

4.28 Vendor ID1 Register (Index 7Ch)

D15	D14	D13	D12	D11	D10	D9	D8	D7	D6	D5	D4	D3	D2	D1	D0
F7	F6	F5	F4	F3	F2	F1	F0	S7	S6	S5	S4	S3	S2	S1	S0

F[7:0] First Character of Vendor ID. With a value of F[7:0] = 43h, these bits define the ASCII 'C' character.

S[7:0] Second Character of Vendor ID. With a value of S[7:0] = 52h, these bits define the ASCII 'R' character.

Default 4352h. This register contains read-only data.

4.29 Vendor ID2 Register (Index 7Eh)

D15	D14	D13	D12	D11	D10	D9	D8	D7	D6	D5	D4	D3	D2	D1	D0
T7	T6	T5	T4	T3	T2	T1	T0	0	DID2	DID1	DID0	0	REV2	REV1	REV0

T[7:0] Third Character of Vendor ID. With a value of T[7:0] = 59h, these bits define the ASCII 'Y' character.

DID[2:0] Device ID. With a value of DID[2:0] = 111, these bits specify the audio codec is a CS4202.

REV[2:0] Revision. With a value of REV[2:0] = 001, these bits specify the audio codec revision is 'A'.

Default 597xh. This register contains read-only data.

The two Vendor ID registers provide a means to determine the manufacturer of the AC '97 audio codec. The first three bytes of the Vendor ID registers contain the ASCII code for the first three letters of Crystal (CRY). The final byte of the Vendor ID registers is divided into a Device ID field and a Revision field. Table 13 lists the currently defined Device ID's.

DID2 - DID0	Part Name
000	CS4297
001	CS4297A
010	CS4294/CS4298
011	CS4299
100	CS4201
101	CS4205
110	CS4291
111	CS4202

Table 13. Device ID with Corresponding Part Number

5. SERIAL DATA PORTS

5.1 Overview

The CS4202 implements two serial data output ports that can be used for multi-channel expansion. Each serial port consists of 4 signals: MCLK, SCLK, LRCLK, and SDATA. The existing 256 Fs BIT_CLK will be used as MCLK. The clock pins are shared between all the serial ports with only the SDATA pins being separate; SDOUT for the first output port, and SDO2 for the second output port. Serial data is transmitted on these ports every AC-link frame.

The serial data port is controlled by the SDEN, SDSC, and SDO2 bits in the *Serial Port Control Register (Index 6Ah)*. All the serial data port pins are multiplexed with other functions and cannot be used unless the other function is disabled or powered down; see Section 7, *Exclusive Functions*. Some audio DACs can run in an internal SCLK mode where SCLK is internally derived from MCLK and LRCLK. In this case, SCLK generation in the CS4202 is optional.

A feature has been designed into the CS4202 that allows the phase of the internal DACs to be reversed. This DAC phase reversal is controlled by

the DPC bit in the *Misc. Crystal Control Register (Index 60h)*. This feature is necessary since the phase response for external DACs is unknown and the phase response of the internal DACs can vary depending on the path determined by the DDM bit in the *AC Mode Control Register (Index 5Eh)* and the output (LINE_OUT or HP_OUT) being used. This feature guarantees that all DACs in a system have the same phase response, maintaining the accuracy of spatial cues.

Please note the data sent to the serial ports is straight from the AC-link. There is no SRC and no volume control available on this data, so it is the responsibility of the controller or host software to provide this functionality if desired.

5.2 Multi-Channel Expansion

For multi-channel expansion, the two serial data output ports are used to send AC-link data to one or two external stereo DACs to support up to a total of six channels. The first serial port takes the digital audio data from the SDOUT slots. The second serial port takes the digital audio data from the SDO2 slots. See Table 8 on page 30 for the actual slots used depending on configuration. Figure 10 shows a six channel application using the CS4202.

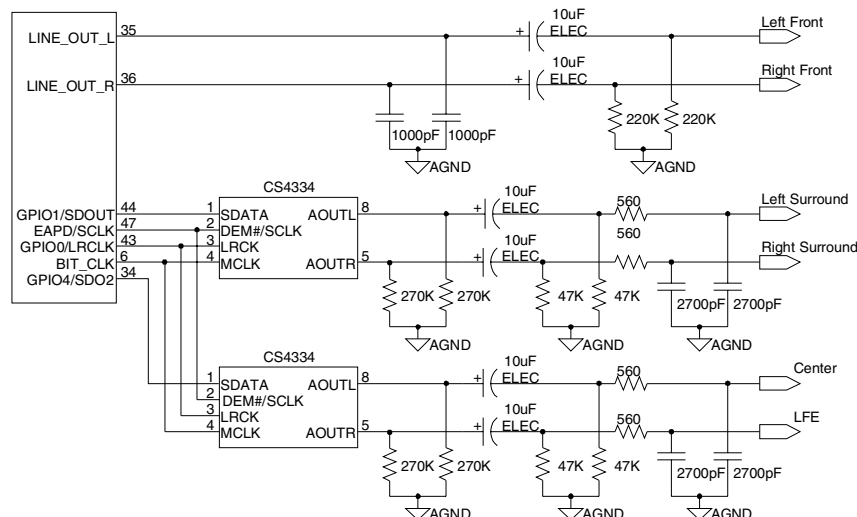

Figure 10. Serial Data Port: Six Channel Circuit

5.3 Serial Data Formats

In order to support a wide variety of serial audio DACs, the CS4202 can transmit serial data in four different formats. The desired format is selected through the SDF[1:0] bits in the *Serial Port Control Register (Index 6Ah)*. All serial ports use the same serial data format when enabled. In all cases, LRCLK will be synchronous with Fs, and SCLK will

be 64 Fs (BIT_CLK/4). Serial data is transitioned by the CS4202 on the falling edge of SCLK and latched by the DACs on the next rising edge. Serial data is shifted out MSB first in all supported formats, but LRCLK polarity as well as data justification, alignment, and resolution vary. Table 14 shows the principal characteristics of each serial format.

SDF[1:0]	LRCLK Polarity	Data Justification	Data Alignment (MSB vs. LRCLK)	Data Resolution	Timing Diagram	Recommended DAC
0 0	negative	left justified	1 SCLK delayed	20-bit	Figure 11	CS4334
0 1	positive	left justified	not delayed	20-bit	Figure 12	CS4335
1 0	positive	right justified	not delayed	20-bit	Figure 13	CS4337
1 1	positive	right justified	not delayed	16-bit	Figure 14	CS4338

Table 14. Serial Data Formats and Compatible DACs for the CS4202

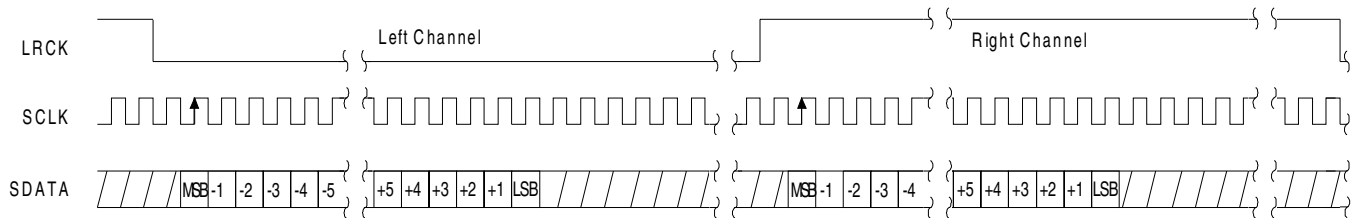

Figure 11. Serial Data Format 0 (I²S)

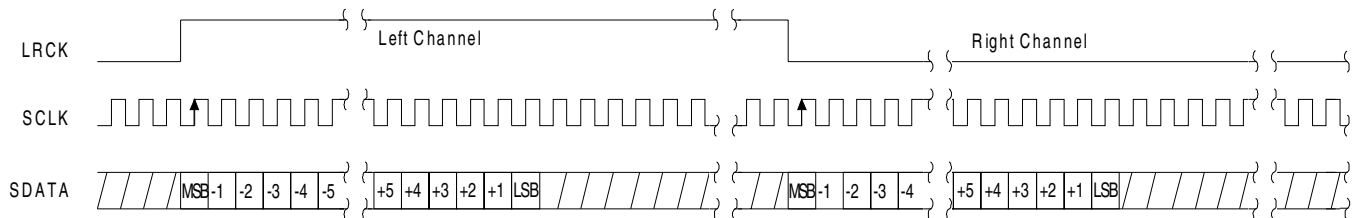

Figure 12. Serial Data Format 1 (Left Justified)

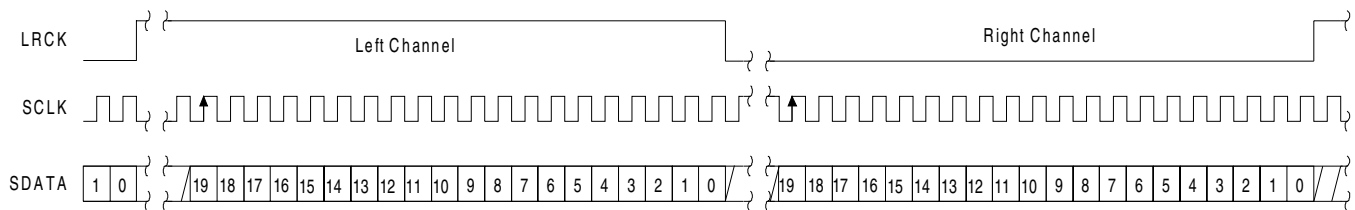

Figure 13. Serial Data Format 2 (Right Justified, 20-bit data)

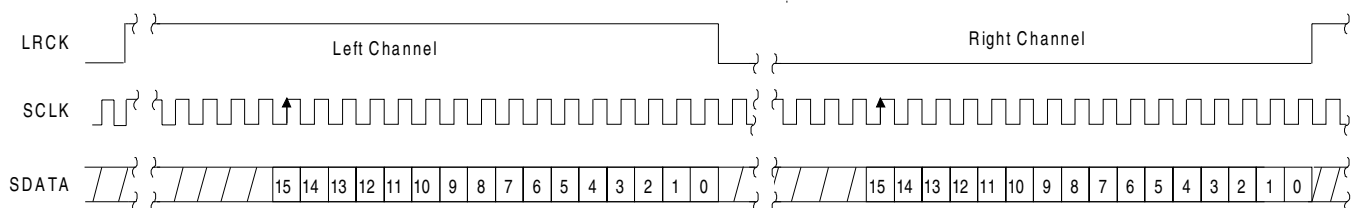

Figure 14. Serial Data Format 3 (Right Justified, 16-bit data)

6. SONY/PHILIPS DIGITAL INTERFACE (S/PDIF)

The S/PDIF digital output is used to interface the CS4202 to consumer audio equipment external to the PC. This output provides an interface for storing digital audio data or playing digital audio data to digital speakers. Figure 15 illustrates the circuits necessary for implementing the IEC-958 optical or consumer interface. For further information on S/PDIF operation see application note *AN22: Overview of Digital Audio Interface Data Structures* [3]. For further information on S/PDIF recommended transformers see application note *AN134: AES and S/PDIF Recommended Transformers* [4].

7. EXCLUSIVE FUNCTIONS

Some of the digital pins on the CS4202 have multiplexed functionality. These functions are mutually exclusive and cannot be requested at the same time. The following pairs of functions are mutually exclusive:

- GPIO and Serial Data Port (GPIO0 pin is shared with LRCLK pin, GPIO1 pin is shared

with SDO2 pin, and GPIO4 pin is shared with SDO2 pin)

- EAPD and Serial Data Port Serial Clock (EAPD pin is shared with SCLK pin)

Use of the GPIO0/LRCLK, GPIO1/SDOUT, and GPIO4/SDO2 pins for serial data port has priority over their GPIO functionality. There is no priority assigned to the other exclusive function. A function currently in use must be disabled or powered down before the corresponding exclusive function can be enabled. The following control bits for these functions will behave differently than normal bits: the EAPD bit in the *Powerdown Control/Status Register (Index 26h)*, the GC[4,1:0] bits in the *GPIO Pin Configuration Register (Index 4Ch)*, and the SDO2, and SDSC bits in the *Serial Port Control Register (Index 6Ah)*. These bits can become read-only bits if they control a feature that is currently unavailable because the corresponding exclusive feature is already in use, or the corresponding master control for this feature is not set.

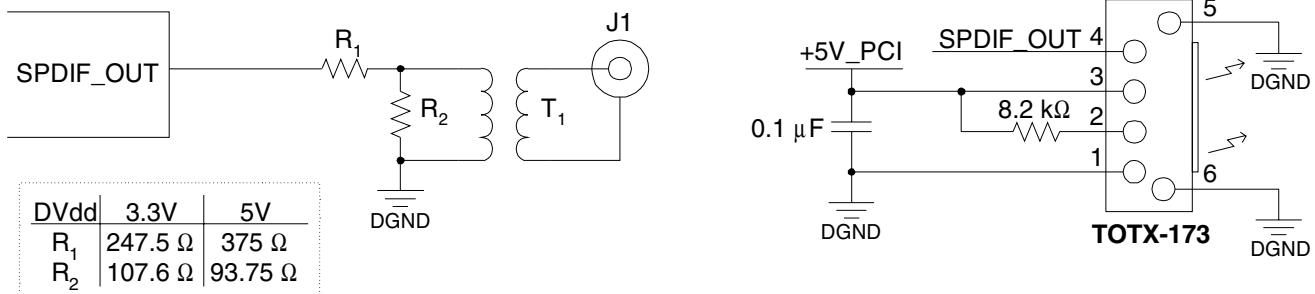

Figure 15. S/PDIF Output

8. POWER MANAGEMENT

8.1 AC '97 Reset Modes

The CS4202 supports four reset methods, as defined in the AC '97 Specification: *Cold Reset*, *Warm Reset*, *New Warm Reset*, and *Register Reset*. A Cold Reset results in all AC '97 logic (registers included) initialized to its default state. A Warm Reset or New Warm Reset leaves the contents of the AC '97 register set unaltered. A Register Reset initializes only the AC '97 registers to their default states.

8.1.1 Cold Reset

A Cold Reset is achieved by asserting RESET# for a minimum of 1 μ s after the power supply rails have stabilized. This is done in accordance with the minimum timing specifications in the *AC '97 Serial Port Timing* section on page 9. Once de-asserted, all of the CS4202 registers will be reset to their default power-on states and the BIT_CLK and SDATA_IN signals will be reactivated.

8.1.2 Warm Reset

A Warm Reset allows the AC-link to be reactivated without losing information in the CS4202 registers. A Warm Reset is required to resume from a D3_{hot} state where the AC-link had been halted yet full power had been maintained. A primary codec Warm Reset is initiated when the SYNC signal is driven high for at least 1 μ s and then driven low in the absence of the BIT_CLK clock signal. The BIT_CLK clock will not restart until at least 2 nor-

mal BIT_CLK clock periods (162.8 ns) after the SYNC signal is de-asserted. A Warm Reset of the secondary codec is recognized when the primary codec on the AC-link resumes BIT_CLK generation. The CS4202 will wait for BIT_CLK to be stable to restore SDATA_IN activity, S/PDIF and/or serial data port transmission on the following frame.

8.1.3 New Warm Reset

The New Warm Reset also allows the AC-link to be reactivated without losing information in the registers. A New Warm Reset is required to resume from a D3_{cold} state where AC-link power has been removed. New Warm Reset is recognized by the low-high transition of RESET# after the AC-link has been programmed into PR4 powerdown. The New Warm Reset functionality can be disabled by setting the CRST bit in the *Misc. Crystal Control Register (Index 60h)*.

8.1.4 Register Reset

The last reset mode provides a Register Reset to the CS4202. This is available only when the CS4202 AC-link is active and the Codec Ready bit is 'set'. The audio (including extended audio) control registers (Index 00h - 3Ah) and the vendor specific registers (Index 5Ah - 7Ah) are reset to their default states by a write of any value to the Reset Register (Index 00h). The modem (including GPIO) registers (*Index 3Ch - 56h*) are reset to their default states by a write of any value to the *Extended Modem ID Register (Index 3Ch)*.

8.2 Powerdown Controls

The *Powerdown Control/Status Register (Index 26h)* controls the power management functions. The PR[6:0] bits in this register control the internal powerdown states of the CS4202. Powerdown control is available for individual subsections of the CS4202 by asserting any PRx bit or any combination of PRx bits. All powerdown states except PR4 and PR5 can be resumed by clearing the corresponding PRx bit. Table 15 shows the mapping of the power control bits to the functions they manage.

When PR0 is ‘set’, the L/R ADCs and the Input Mux are shut down and the ADC bit in the *Powerdown Control/Status Register (Index 26h)* is ‘cleared’ indicating the ADCs are no longer in a ready state. The same is true for PR1 and the DACs, PR2 and the analog mixer, PR3 and the voltage reference (Vrefout), and PR6 and the headphone amplifier. When one of these bits is ‘cleared’, the corresponding subsystem will begin a power-on process, and the associated status bit will be ‘set’ when the hardware is ready.

In a primary codec the PR4 bit powers down the AC-link, but all other analog and digital sub-

systems continue to function. The required resume sequence from a PR4 state is either a Warm Reset or a New Warm Reset, depending on whether a D3_{hot} or D3_{cold} state has been entered.

The PR5 bit disables all internal clocks and powers down the DACs and the ADCs, but maintains operation of the BIT_CLK and the analog mixer. A Cold Reset is the only way to restore operation to the CS4202 after asserting PR5. To achieve a complete digital powerdown, PR4 and PR5 must be asserted within a single AC output frame. This will also drive BIT_CLK ‘low’.

The CS4202 does not automatically mute any input or output when the powerdown bits are ‘set’. The software driver controlling the AC ’97 device must manage muting the input and output analog signals before putting the part into any power management state. The definition of each PRx bit may affect a single subsection or a combination of subsections within the CS4202. Table 16 contains the matrix of subsections affected by the respective PRx function. Table 17 shows the different operating power consumption levels for different powerdown functions.

PR Bit	Function
PR0	L/R ADCs and Input Mux Powerdown
PR1	Front DACs Powerdown
PR2	Analog Mixer Powerdown (Vref on)
PR3	Analog Mixer Powerdown (Vref off)
PR4	AC-link Powerdown (BIT_CLK off)*
PR5	Internal Clock Disable
PR6	Headphone Out Powerdown

* Applies only to primary codec

Table 15. Powerdown PR Bit Functions

PR Bit	ADCs	DACs	Mixer	Analog Reference	AC Link	Internal Clock Off	Headphone
PR0	•						
PR1		•					
PR2	•	•	•				•
PR3	•	•	•	•			•
PR4					•		
PR5	•	•				•	
PR6							•

Table 16. Powerdown PR Function Matrix for the CS4202

Power State	I _{DVdd} (mA) [DVdd=3.3 V]	I _{DVdd} (mA) [DVdd=5 V]	I _{AVdd1} (mA)	I _{AVdd2} (mA)
Full Power + SRC's	25.2	40.2	31.3	5.1
Full Power + S/PDIF ¹	30.0	46.6	31.3	5.1
Full Power + HP ²	26.4	41.5	32.1	39.5
Full Power	26.4	41.5	31.3	5.1
ADCs off (PR0)	24.0	37.9	23.2	4.9
DACs off (PR1)	24.3	38.4	25.8	5.0
Audio off (PR2)	21.9	34.9	3.8	0 μA
Vref off (PR3)	21.9	34.9	1.5	0 μA
AC-Link off (PR4)	21.8	35.3	31.2	5.1
Internal Clocks off (PR5)	3.8	6.3	19.0	4.6
HP amp off (PR6)	26.3	41.5	29.8	0 μA
Digital off (PR4+PR5)	10 μA	21 μA	19.0	4.6
All off (PR3+PR4+PR5)	10 μA	21 μA	1.3	0 μA
RESET	0.8	1.4	3.6	0 μA

Table 17. Power Consumption by Powerdown Mode for the CS4202

¹ Assuming standard resistive load for transformer coupled coaxial S/PDIF output (R_{load} = 292 Ohm, DVdd = 3.3 V) (R_{load} = 415 Ohm, DVdd = 5 V). General: I_{DVdd} S/PDIF = I_{DVdd} + DVdd/R_{load}/2

² HP_OUT_L, HP_OUT_R driving 4 Vpp into 32 Ohm resistive load.

9. CLOCKING

The CS4202 may be operated as a primary or secondary codec. As a primary codec, the system clock for the AC-link may be generated from an external 24.576 MHz clock source, a 24.576 MHz crystal, or the internal Phase Locked Loop (PLL). The PLL allows the CS4202 to accept external clock frequencies other than 24.576 MHz. As a secondary codec, the system clock is derived from BIT_CLK, which is generated by the primary codec. The CS4202 uses the presence or absence of a valid clock on the XTL_IN pin in conjunction with the state of the ID[1:0]# pins to determine the clocking configuration. See Table 18 for all available CS4202 clocking modes.

9.1 PLL Operation (External Clock)

The PLL mode is activated if a valid clock is present on XTL_IN before the rising edge of RESET#. Once PLL mode is entered, the XTL_OUT pin is redefined as the PLL loop filter, as shown in Figure 16. The ID[1:0]# inputs determine the configuration of the internal divider ratios required to generate the 12.288 MHz BIT_CLK output; see Table 18 on page 49 for additional details. In PLL mode, the CS4202 is configured as a primary codec independent of the state of the ID[1:0]# pins. If 24.576 MHz is chosen as the external clock input (ID[1:0]# inputs both pulled high or left floating), the PLL is disabled and the clock is used directly. The loop filter is not required and XTL_OUT is left unconnected. For all other clock input choices, the loop filter is required. The ID[1:0] bits of the *Extended Audio ID Register (Index 28h)* and the *Extended Modem ID Register (Index 3Ch)* will always report '00' in PLL mode.

9.2 24.576 MHz Crystal Operation

If a valid clock is not present on XTL_IN during the rising edge of RESET#, the device disables the PLL input and latches the state of the ID[1:0]# inputs. If the ID[1:0]# inputs are both pulled high or left floating, the device is configured as a primary codec. An external 24.576 MHz crystal is used as the system clock as shown in Figure 17.

9.3 Secondary Codec Operation

If a valid clock is not present on XTL_IN and either ID[1:0]# input is pulled low during the rising edge of RESET#, the device is determined to be a secondary codec. The BIT_CLK pin is configured as an input and the CS4202 is driven from the 12.288 MHz BIT_CLK of the primary codec. The ID[1:0] bits of the *Extended Audio ID Register (Index 28h)* and the *Extended Modem ID Register (Index 3Ch)* will report the state of the ID[1:0]# inputs.

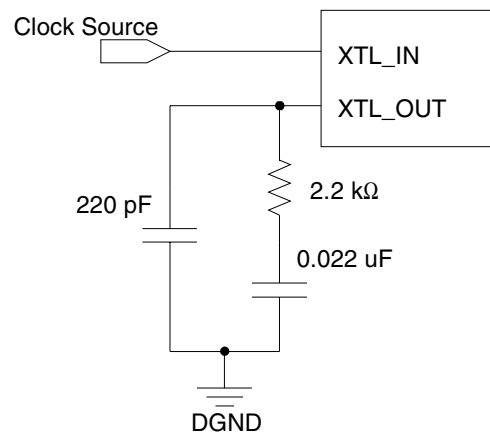
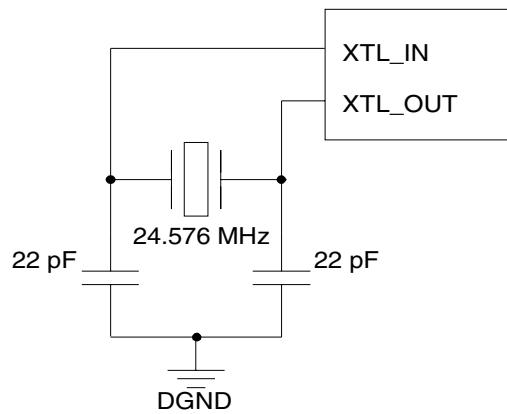

Figure 16. PLL External Loop Filter

Figure 17. External Crystal

External Clock on XTL_IN	ID1#	ID0#	AC-Link Timing Mode	Codec ID	Clock Source	Clock Rate (MHz)	PLL Active	Application Notes
Yes	1	1	Primary	0	External	24.576	No	clock generator driving XTL_IN
Yes	1	0	Primary	0	External	14.31818	Yes	external clock source driving XTL_IN loop filter connected to XTL_OUT
Yes	0	1	Primary	0	External	27.000	Yes	
Yes	0	0	Primary	0	External	48.000	Yes	
No	1	1	Primary	0	XTAL	24.576	No	crystal connected to XTL_IN, XTL_OUT
No	1	0	Secondary	1	BIT_CLK	12.288	No	BIT_CLK from primary codec driving BIT_CLK on all secondary codecs
No	0	1	Secondary	2	BIT_CLK	12.288	No	
No	0	0	Secondary	3	BIT_CLK	12.288	No	

Table 18. Clocking Configurations for the CS4202

10. ANALOG HARDWARE DESCRIPTION

The analog input section consists of four stereo line-level inputs (LINE_L/R, CD_L/C/R, VIDEO_L/R, and AUX_L/R), two selectable mono microphone inputs (MIC1 and MIC2), and two mono inputs (PC_BEEP and PHONE). The analog output section consists of a mono output (MONO_OUT), a stereo headphone output (HP_OUT_L/R), and a stereo line-level output (LINE_OUT_L/R). This section describes the analog hardware needed to interface with these pins. The designs presented in this section are compliant with Chapter 17 of Microsoft's® *PC 99 System Design Guide* [7] (referred to as PC 99) and Chapter 11 of Microsoft's® *PC 2001 System Design Guide* [8] (referred to as PC 2001). For information on EMI reduction techniques refer to the application note *AN165: CS4297A/CS4299 EMI Reduction Techniques* [5].

10.1 Analog Inputs

All analog inputs to the CS4202, including CD_C, should be capacitively coupled to the input pins. Unused analog inputs should be tied together and connected through a capacitor to analog ground or tied to the Vrefout pin directly. The maximum allowed voltage for analog inputs, except the microphone input, is $1 V_{RMS}$. The maximum allowed voltage for the microphone input depends on the selected boost setting.

10.1.1 Line Inputs

Figure 18 shows circuitry for a line-level stereo input. Replicate this circuit for the Video and Aux inputs. This design attenuates the input by 6 dB, bringing the signal from the PC 99 specified $2 V_{RMS}$, to the CS4202 maximum allowed $1 V_{RMS}$.

10.1.2 CD Input

The CD line-level input has an extra pin, CD_C, providing a pseudo-differential input for both

CD_L and CD_R. This pin takes the common-mode noise out of the CD inputs when connected to the CD analog source ground. Following the reference design in Figure 19 provides extra attenuation of common mode noise coming from the CD-ROM drive, thereby producing a higher quality signal. One percent resistors are recommended since closely matched resistor values provide better common-mode attenuation of unwanted signals. The circuit shown in Figure 19 can be used for a $1 V_{RMS}$ CD input signal.

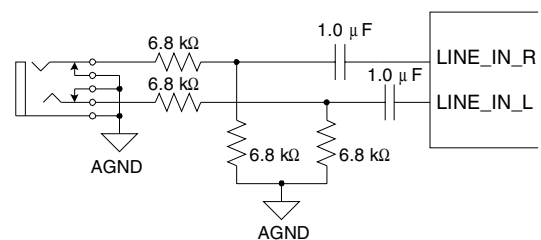

Figure 18. Line Input (Replicate for Video and AUX)

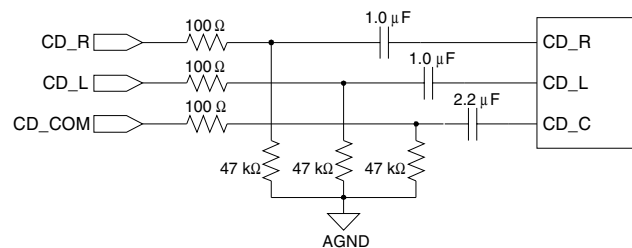

Figure 19. Differential $1 V_{RMS}$ CD Input

10.1.3 Microphone Inputs

Figure 20 illustrates an input circuit suitable for dynamic and electret microphones. Electret, also known as phantom-powered, microphones use the right channel (ring) of the jack for power. The design also supports the recommended advanced frequency response for voice recognition as specified in PC 99 and PC 2001. The microphone input of the CS4202 has an integrated pre-amplifier. Using combinations of the 10dB bit in the *Misc. Crystal Control Register (Index 60)* and the 20dB bit in the

Mic Volume Register (Index 0Eh) the pre-amplifier gain can be set to 0 dB, 10 dB, 20 dB, or 30 dB.

10.1.4 PC Beep Input

The PC_BEEP input is useful for mixing the output of the “beeper” (timer chip), provided in most PCs, with the other audio signals. When the CS4202 is held in reset, PC_BEEP is passed directly to the line output. This allows the system sounds or “beeps” to be available before the AC '97 interface has been activated. Figure 21 illustrates a typical input circuit for the PC_BEEP input. If PC_BEEP is driven from a CMOS gate, the 4.7 kΩ resistor should be tied to analog ground instead of +5VA. Although this input is described for a low-quality “beeper”, it is of the same high-quality as all other analog inputs and may be used for other purposes.

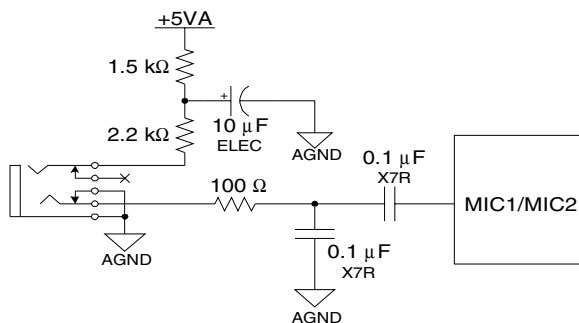

Figure 20. Microphone Input

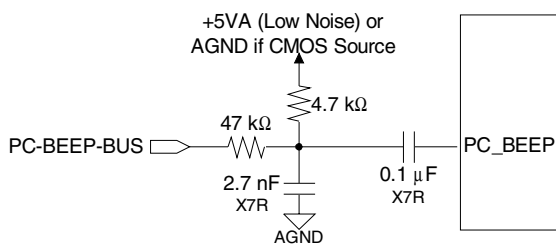

Figure 21. PC_BEEP Input

10.1.5 Phone Input

One application of the PHONE input is to interface to the output of a modem analog front end (AFE) device so that modem dialing signals and protocol negotiations may be monitored through the audio system. Figure 22 shows a design for a modem connection where the output is fed from the CS4202 MONO_OUT pin through a divider. The divider ratio shown does not attenuate the signal, providing an output voltage of 1 V_{RMS} . If a lower output voltage is desired, the resistors can be replaced with appropriate values, as long as the total load on the output is kept greater than 10 kΩ. The PHONE input is divided by 6 dB to accommodate a line-level source of 2 V_{RMS} .

10.2 Analog Outputs

The analog output section provides a stereo, a headphone, and a mono output. The MONO_OUT, LINE_OUT_L, and LINE_OUT_R pins require 680 pF to 1000 pF NPO dielectric capacitors between the corresponding pin and analog ground. Each analog output is DC-biased up to the V_{refout} voltage signal reference, nominally 2.4 V. This requires the outputs be AC-coupled to external circuitry (AC loads must be greater than 10 kΩ for the line output or 32 Ω for the headphone output). The headphone coupling capacitors should be 220 μF or greater to minimize low frequency roll-off.

10.2.1 Stereo Outputs

The LINE_OUT and HP_OUT stereo outputs depend on the configuration of the HPCFG pin. As shown in Figure 23, if the HPCFG pin is left floating,

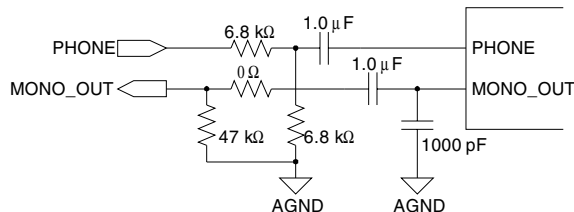

Figure 22. Modem Connection

the part behaves as specified in AC '97. As shown in Figure 24, if the HPCFG pin is grounded, the part behaves as if HP_OUT was the only output. In this case, LINE_OUT will be muted, the *Master Volume Register (Index 02h)* will control HP_OUT and PC_BEEP will be routed to HP_OUT during RESET.

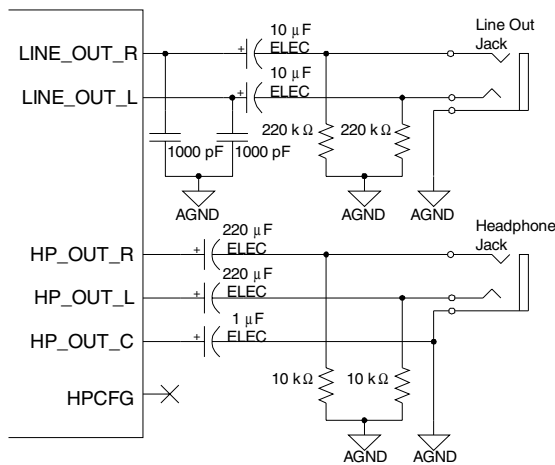

Figure 23. Line Out and Headphone Out Setup

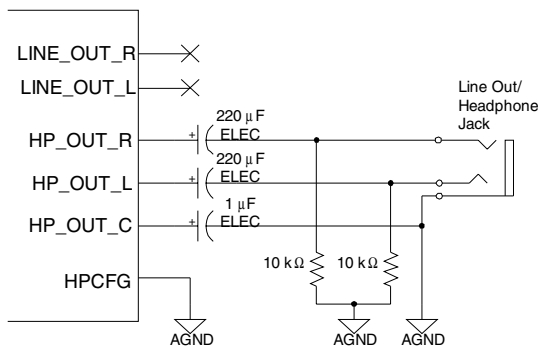

Figure 24. Line Out/Headphone Out Setup

10.2.2 Mono Output

The mono output, MONO_OUT, can be either a sum of the left and right output channels, attenuated by 6 dB to prevent clipping at full scale, or the selected Mic signal. The mono out channel can drive the PC internal mono speaker using an appropriate buffer circuit.

10.3 Miscellaneous Analog Signals

The AFLT1 and AFLT2 pins must have a 1000 pF NPO capacitor to analog ground. These capacitors provide a single-pole low-pass filter at the inputs to the ADCs. This makes low-pass filters at each analog input pin unnecessary.

The REFFLT pin must have a short, wide trace to a 2.2 µF and a 0.1 µF capacitor connected to analog ground (see Figure 26 in Section 11, *Grounding and Layout*, for an example). The 2.2 µF capacitor must not be replaced by any other value (it may be replaced with two 1 µF capacitors in parallel) and must be ceramic with low leakage current. Electrolytic capacitors should not be used. No other connection should be made, as any coupling onto this pin will degrade the analog performance of the CS4202. Likewise, digital signals should be kept away from REFFLT for similar reasons.

10.4 Power Supplies

The power supplies providing analog power should be as clean as possible to minimize coupling into the analog section which could degrade analog performance. The +5 V analog supply should be generated from a voltage regulator (7805 type) connected to a +12 V supply. This helps isolate the analog circuitry from noise typically found on +5 V digital supplies. A typical voltage regulator circuit for analog power using an MC78M05CDT is shown in Figure 25. One analog power pin, AVdd2, supplies power to the headphone amplifier on the CS4202. The other analog power pin, AVdd1, supplies power to the rest of the CS4202 analog circuitry. The digital power pins, DVdd1 and DVdd2, should be connected to the same

digital supply as the controller's AC-link interface. Since the digital interface on the CS4202 may operate at either +3.3 V or +5 V, proper connection of these pins will depend on the digital power supply of the controller.

10.5 Reference Design

See Section 14 for a CS4202 reference design.

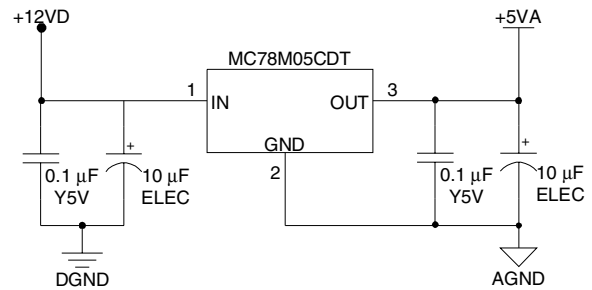

Figure 25. +5V Analog Voltage Regulator

11. GROUNDING AND LAYOUT

Figure 26 on page 55 shows the conceptual layout for the CS4202 in XTAL or OSC clocking modes. The decoupling capacitors should be located physically as close to the pins as possible. Also, note the connection of the REFFLT decoupling capacitors to the ground return trace connected directly to the ground return pin, AVss1.

It is strongly recommended that separate analog and digital ground planes be used. Separate ground planes keep digital noise and return currents from modulating the CS4202 ground potential and degrading performance. The digital ground pins should be connected to the digital ground plane and kept separate from the analog ground connections of the CS4202 and any other external analog circuitry. All analog components and traces should be located over the analog ground plane and all digital components and traces should be located over the digital ground plane.

The common connection point between the two ground planes (required to maintain a common ground voltage potential) should be located under the CS4202. The AC-link digital interface connec-

tion traces should be routed such that the digital ground plane lies underneath these signals (on the internal ground layer). This applies along the entire length of these traces from the AC '97 controller to the CS4202.

Refer to the Application Note *AN18: Layout and Design Rules for Data Converters and Other Mixed Signal Devices* [2] for more information on layout and design rules.

Schematic & Layout Review Service

**Confirm Optimum
Schematic & Layout
Before Building Your Board.**

**For Our Free Review Service
Call Applications Engineering.**

C a l l : (5 1 2) 4 4 5 - 7 2 2 2



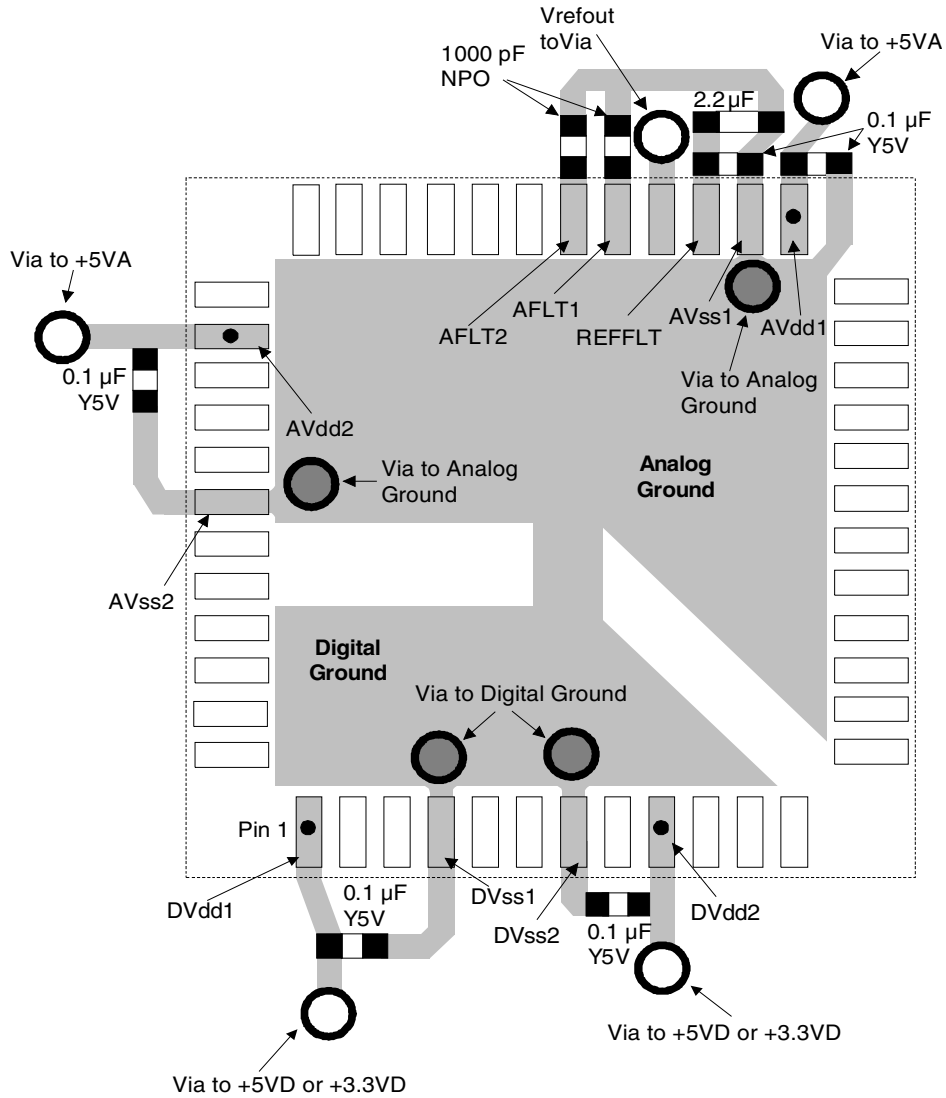
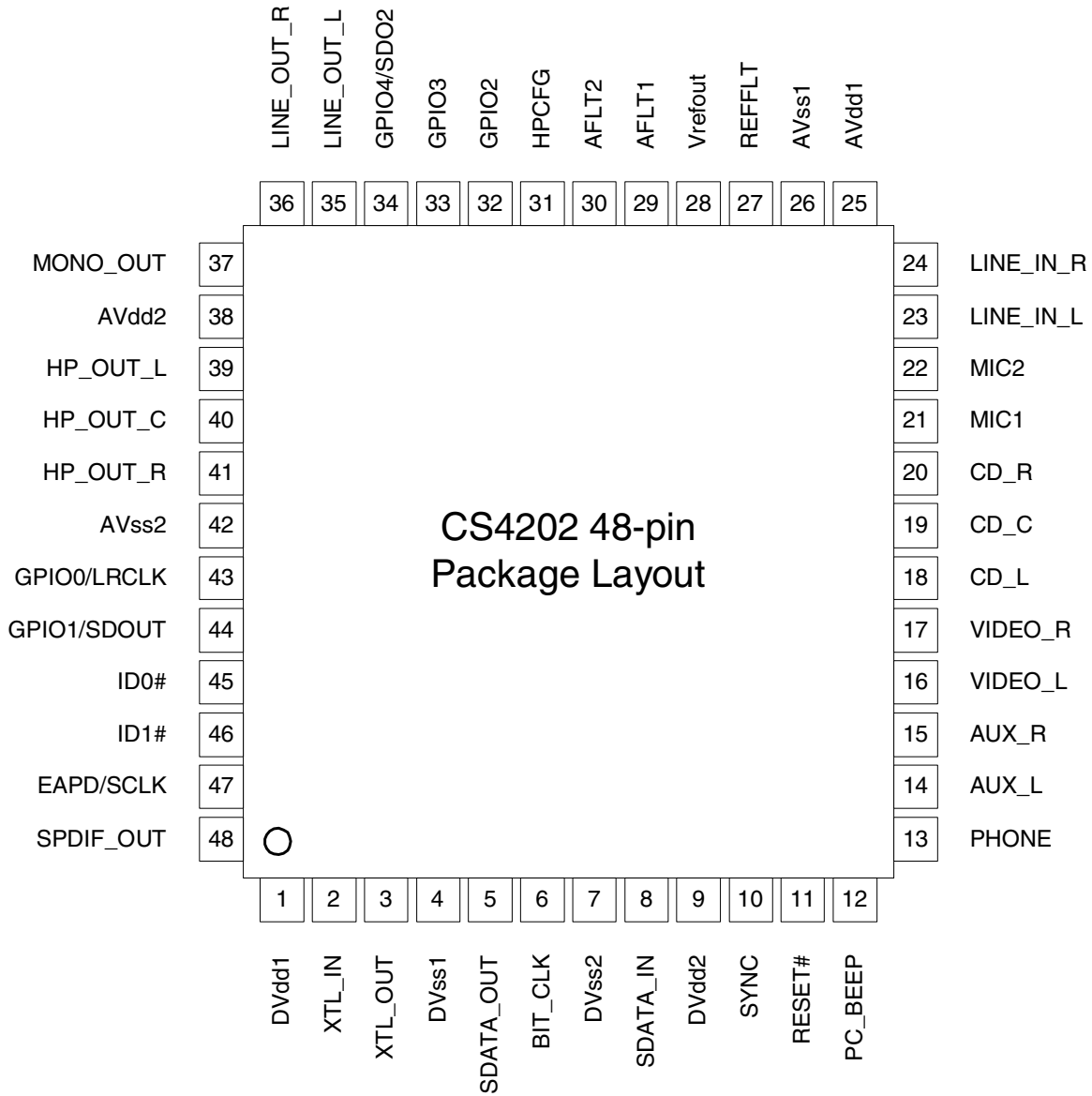

Figure 26. Conceptual Layout for the CS4202 when in XTAL or OSC Clcking Modes

12. PIN DESCRIPTIONS

Figure 27. Pin Locations for the CS4202

Audio I/O Pins

PC_BEEP - Analog Mono Source, Input, Pin 12

The PC_BEEP input is intended to allow the PC system POST (Power On Self-Test) tones to pass through to the audio subsystem. The PC_BEEP input has two connections: the first connection is to the analog output mixer, the second connection is directly to the LINE_OUT stereo outputs (if HPCFG is floating) or through the headphone amplifier to the HP_OUT pins (if HPCFG is tied low). While the RESET# pin is actively being asserted to the CS4202, the PC_BEEP bypass path to the LINE_OUT or HP_OUT outputs is enabled. While the CS4202 is in normal operation mode with RESET# de-asserted, PC_BEEP is a monophonic source to the analog output mixer. The maximum allowable input is $1 V_{RMS}$ (sinusoidal). This input is internally biased at the Vrefout voltage reference and requires AC-coupling to external circuitry. If this input is not used, it should be connected to the Vrefout pin or AC-coupled to analog ground.

PHONE - Analog Mono Source, Input, Pin 13

This analog input is a monophonic source to the output mixer. It is intended to be used as a modem subsystem input to the audio subsystem. The maximum allowable input is $1 V_{RMS}$ (sinusoidal). This input is internally biased at the Vrefout voltage reference and requires AC-coupling to external circuitry. If this input is not used, it should be connected to the Vrefout pin or AC-coupled to analog ground.

MIC1 - Analog Mono Source, Input, Pin 21

This analog input is a monophonic source to the analog output mixer. It is intended to be used as a desktop microphone connection to the audio subsystem. The CS4202 internal mixer's microphone input is MUX selectable with either MIC1 or MIC2 as the input. The maximum allowable input is $1 V_{RMS}$ (sinusoidal). This input is internally biased at the Vrefout voltage reference and requires AC-coupling to external circuitry. If this input is not used, it should be connected to the Vrefout pin or AC-coupled to analog ground.

MIC2 - Analog Mono Source, Input, Pin 22

This analog input is a monophonic source to the analog output mixer. It is intended to be used as an alternate microphone connection to the audio subsystem. The CS4202 internal mixer's microphone input is MUX selectable with either MIC1 or MIC2 as the input. The maximum allowable input is $1 V_{RMS}$ (sinusoidal). This input is internally biased at the Vrefout voltage reference and requires AC-coupling to external circuitry. If this input is not used, it should be connected to the Vrefout pin or AC-coupled to analog ground.

LINE_IN_L, LINE_IN_R - Analog Line Source, Inputs, Pins 23 and 24

These inputs form a stereo input pair to the CS4202. The maximum allowable input is $1 V_{RMS}$ (sinusoidal). These inputs are internally biased at the Vrefout voltage reference and require AC-coupling to external circuitry. If these inputs are not used, they should both be connected to the Vrefout pin or AC-coupled to analog ground.

CD_L, CD_R - Analog CD Source, Inputs, Pins 18 and 20

These inputs form a stereo input pair to the CS4202. It is intended to be used for the Red Book CD audio connection to the audio subsystem. The maximum allowable input is $1 V_{RMS}$ (sinusoidal). These inputs are internally biased at the Vrefout voltage reference and require AC-coupling to external circuitry. If these inputs are not used, they should both be connected to the Vrefout pin or AC-coupled to analog ground.

CD_C - Analog CD Common Source, Input, Pin 19

This analog input is used to remove common mode noise from Red Book CD audio signals. The impedance on the input signal path should be one half the impedance on the CD_L and CD_R input paths. This pin requires AC-coupling to external circuitry. If this input is not used, it should be connected to the Vrefout pin or AC-coupled to analog ground.

VIDEO_L, VIDEO_R - Analog Video Audio Source, Inputs, Pins 16 and 17

These inputs form a stereo input pair to the CS4202. It is intended to be used for the audio signal output of a video device. The maximum allowable input is $1 V_{RMS}$ (sinusoidal). These inputs are internally biased at the Vrefout voltage reference and require AC-coupling to external circuitry. If these inputs are not used, they should both be connected to the Vrefout pin or AC-coupled to analog ground.

AUX_L, AUX_R - Analog Auxiliary Source, Inputs, Pins 14 and 15

These inputs form a stereo input pair to the CS4202. The maximum allowable input is $1 V_{RMS}$ (sinusoidal). These inputs are internally biased at the Vrefout voltage reference and require AC-coupling to external circuitry. If these inputs are not used, they should both be connected to the Vrefout pin or AC-coupled to analog ground.

LINE_OUT_L, LINE_OUT_R - Analog Line-Level, Outputs, Pins 35 and 36

These signals are analog outputs from the stereo output mixer. The full-scale output voltage for each output is nominally $1 V_{RMS}$ (sinusoidal). These outputs are internally biased at the Vrefout voltage reference and require either AC-coupling to external circuitry or DC-coupling to a buffer op-amp biased at the Vrefout voltage. These pins need a 680-1000 pF NPO capacitor attached to analog ground.

HP_OUT_L, HP_OUT_R - Analog Headphone, Outputs, Pins 39 and 41

These signals are analog outputs from the stereo output mixer. The full-scale output voltage for each output is nominally $4 V_{pp}$. These outputs are internally biased at the Vrefout voltage reference and require AC-coupling to external circuitry. The HP_OUT pins can directly drive resistive loads as low as 32Ω (such as standard consumer headphones). Capacitive loading must not exceed 200 pF per pin. The outputs are short circuit protected for infinite duration.

HP_OUT_C - Analog Headphone Output Common Source, Input, Pin 40

This analog input is used to remove common mode noise from the headphone outputs. This is achieved by biasing the headphone amplifier with the common mode noise on the headphone amplifier ground plane. This pin should be AC-coupled through a $1 \mu F$ electrolytic capacitor to analog ground (AVss2) near the headphone jack.

MONO_OUT - Analog Mono Line-Level, Output, Pin 37

This signal is an analog output from the stereo-to-mono mixer. The full-scale output voltage for this output is nominally $1 V_{RMS}$ (sinusoidal). This output is internally biased at the Vrefout voltage reference and requires either AC-coupling to external circuitry or DC-coupling to a buffer op-amp biased at the Vrefout voltage. This pin needs a 680-1000 pF NPO capacitor attached to analog ground.

Analog Reference, Filter, and Configuration Pins**REFFLT - Internal Reference Voltage, Input, Pin 27**

This signal is the voltage reference used internal to the CS4202. A $0.1 \mu F$ and a $2.2 \mu F$ ceramic capacitor with short, wide traces must be connected to this pin. No other connections should be made to this pin. Do not use an electrolytic $2.2 \mu F$ capacitor, use a type Z5U or Y5V ceramic capacitor.

Vrefout - Voltage Reference, Output, Pin 28

All analog inputs and outputs are centered around Vrefout, nominally 2.4 Volts. This pin may be used to bias external amplifiers. It can also drive up to 5 mA of DC which can be used for microphone bias.

AFLT1 - Left ADC Channel Antialiasing Filter, Input, Pin 29

This pin needs a 1000 pF NPO capacitor connected to analog ground.

AFLT2 - Right ADC Channel Antialiasing Filter, Input, Pin 30

This pin needs a 1000 pF NPO capacitor connected to analog ground.

HPCFG - Headphone Configuration, Input, Pin 31

This pin is the configuration control for the signal routing to the headphone amplifier. If this pin is left floating, the LINE_OUT and HP_OUT pins function as defined in the AC '97 specification. If the HPCFG pin is grounded, the HP_OUT pins behave as a buffered line output. In addition, the LINE_OUT pins are muted, the control register for the headphone output will be the *Master Output Volume Register (Index 02h)*, and PC_BEEP is routed to the HP_OUT pins during RESET. The HPCFG pin is internally pulled up to the analog supply voltage.

AC-Link Pins**RESET# - AC '97 Chip Reset, Input, Pin 11**

This active low signal is the asynchronous Cold Reset input to the CS4202. The CS4202 must be reset before it can enter normal operating mode.

SYNC - AC-Link Serial Port Sync Pulse, Input, Pin 10

SYNC is the serial port timing signal for the AC-link. Its period is the reciprocal of the maximum sample rate, 48 kHz. The signal is generated by the controller and is synchronous to BIT_CLK. SYNC is an asynchronous input when the CS4202 is configured as a primary codec and is in a PR4 powerdown state. A series terminating resistor of 47 Ω should be connected on this signal close to the controller.

BIT_CLK - AC-Link Serial Port Master Clock, Input/Output, Pin 6

This input/output signal controls the master clock timing for the AC-link. In primary mode, this signal is a 12.288 MHz output clock derived from either a 24.576 MHz crystal or from the internal PLL based on the XTL_IN input clock. When the CS4202 is in secondary mode, this signal is an input which controls the AC-link serial interface and generates all internal clocking including the AC-link serial interface timing and the analog sampling clocks. A series terminating resistor of 47 Ω should be connected on this signal close to the CS4202 in primary mode or close to the BIT_CLK source in secondary mode.

SDATA_OUT - AC-Link Serial Data Input Stream to AC '97, Input, Pin 5

This input signal receives the control information and digital audio output streams. The data is clocked into the CS4202 on the falling edge of BIT_CLK. A series terminating resistor of 47 Ω should be connected on this signal close to the controller.

SDATA_IN - AC-Link Serial Data Output Stream from AC '97, Output, Pin 8

This output signal transmits the status information and digital audio input streams from the ADCs. The data is clocked out of the CS4202 on the rising edge of BIT_CLK. A series terminating resistor of 47 Ω should be connected on this signal close to the CS4202.

Clock and Configuration Pins

XTL_IN - Crystal Input / Clock Input, Pin 2

This pin requires either a 24.576 MHz crystal, with the other pin attached to XTL_OUT, or an external CMOS clock. XTL_IN must have a crystal or clock source attached for proper operation except when operating in secondary codec mode. The crystal frequency must be 24.576 MHz and designed for fundamental mode, parallel resonance operation. If an external CMOS clock is used to drive this pin, it must run at one of these acceptable frequencies: 14.31818, 24.576, 27, or 48 MHz. When configured as a secondary codec, all timing is derived from the BIT_CLK input signal and this pin should be left floating. See Section 9, *Clocking*, for additional details.

XTL_OUT - Crystal Output / PLL Loop Filter, Pin 3

This pin is used for a crystal placed between this pin and XTL_IN. If an external 24.576 MHz clock is used on XTL_IN, this pin must be left floating with no traces or components connected to it. If one of the other acceptable clocks is used on XTL_IN, this pin must be connected to a loop filter circuit. See Section 9, *Clocking*, for additional details.

ID1#, ID0# - Codec ID, Inputs, Pins 45 and 46

These pins select the Codec ID for the CS4202, as well as determine the rate of the incoming clock in PLL mode. They are only sampled after the rising edge of RESET#. These pins are internally pulled up to the digital supply voltage and should be left floating for logic '0' or tied to digital ground for logic '1'.

Misc. Digital Interface Pins

SPDIF_OUT - Sony/Philips Digital Interface, Output, Pin 48

This pin generates the S/PDIF digital output from the CS4202 when the SPDIF bit in the *Extended Audio Status/Control Register (Index 2Ah)* is 'set'. This output may be used to directly drive a resistive divider and coupling transformer to an RCA-type connector for use with consumer audio equipment. When this function is not being used this output is driven to a logic '0'.

EAPD/SCLK - External Amplifier Powerdown / Serial Clock, Output, Pin 47

This pin is used to control the powerdown state of an audio amplifier external to the CS4202. The output is controlled by the EAPD bit in the Powerdown Ctrl/Stat Register (Index 26h). It is driven as a normal CMOS output and defaults low ('0') upon power-up. This pin also provides the serial clock for both serial data ports when the SDSC bit in the *Serial Port Control Register (Index 6Ah)* is 'set'.

GPIO0/LRCLK - General Purpose I/O / Left-Right Clock, Input/Output, Pin 43

This pin is a general purpose I/O pin that can be used to interface with various external circuitry. When configured as an input, it functions as a Schmitt triggered input with 350 mV hysteresis at 5 V and 220 mV hysteresis at 3.3 V. When configured as an output, it can function as a normal CMOS output (4 mA drive) or as an open drain output. This pin also provides the L/R clock for both serial data ports when the SDEN bit in the *Serial Port Control Register (Index 6Ah)* is 'set'. This pin powers up in the high impedance state for backward compatibility.

GPIO1/SDOUT - General Purpose I/O / Serial Data Output, Input/Output, Pin 44

This pin is a general purpose I/O pin that can be used to interface with various external circuitry. When configured as an input, it functions as a Schmitt triggered input with 350 mV hysteresis at 5 V and 220 mV hysteresis at 3.3 V. When configured as an output, it can function as a normal CMOS output (4 mA drive) or as an open drain output. This pin also provides the serial data for the first serial data port when the SDEN bit in the *Serial Port Control Register (Index 6Ah)* is 'set'. This pin powers up in the high impedance state for backward compatibility.

GPIO2 - General Purpose I/O, Input/Output, Pin 32

This pin is a general purpose I/O pin that can be used to interface with various external circuitry. When configured as an input, it functions as a Schmitt triggered input with 350 mV hysteresis at 5 V and 220 mV hysteresis at 3.3 V. When configured as an output, it can function as a normal CMOS output (4 mA drive) or as an open drain output. This pin powers up in the high impedance state for backward compatibility.

GPIO3 - General Purpose I/O, Input/Output, Pin 33

This pin is a general purpose I/O pin that can be used to interface with various external circuitry. When configured as an input, it functions as a Schmitt triggered input with 350 mV hysteresis at 5 V and 220 mV hysteresis at 3.3 V. When configured as an output, it can function as a normal CMOS output (4 mA drive) or as an open drain output. This pin powers up in the high impedance state for backward compatibility.

GPIO4/SDO2 - General Purpose I/O / Serial Data Output 2, Input/Output, Pin 34

This pin is a general purpose I/O pin that can be used to interface with various external circuitry. When configured as an input, it functions as a Schmitt triggered input with 350 mV hysteresis at 5 V and 220 mV hysteresis at 3.3 V. When configured as an output, it can function as a normal CMOS output (4 mA drive) or as an open drain output. This pin also provides the serial data for the second serial data port when the SDO2 bit in the *Serial Port Control Register (Index 6Ah)* is 'set'. This pin powers up in the high impedance state for backward compatibility.

*Power Supply Pins***DVdd1, DVdd2 - Digital Supply Voltage, Pins 1 and 9**

Digital supply voltage for the AC-link section of the CS4202. These pins can be tied to +5 V digital or to +3.3 V digital. The CS4202 and controller's AC-link should share a common digital supply.

DVss1, DVss2 - Digital Ground, Pins 4 and 7

Digital ground connection for the AC-link section of the CS4202. These pins should be isolated from analog ground currents.

AVdd1, AVdd2 - Analog Supply Voltage, Pins 25 and 38

Analog supply voltage for the analog and mixed signal section of the CS4202 (AVdd1) as well as the headphone amplifier (AVdd2). These pins must be tied to the analog +5 V power supply. It is strongly recommended that +5 V be generated from a voltage regulator to ensure proper supply currents and noise immunity from the rest of the system.

AVss1, AVss2 - Analog Ground, Pins 26 and 42

Ground connection for the analog, mixed signal, and substrate sections of the CS4202 (AVss1) as well as the headphone amplifier (AVss2). These pins should be isolated from digital ground currents.

13. PARAMETER AND TERM DEFINITIONS

AC '97 Specification

Refers to the *Audio Codec '97 Component Specification Ver 2.2* published by the Intel® Corporation [6].

AC '97 Controller or Controller

Refers to the control chip which interfaces to the audio codec AC-link. This has been also called *DC '97* for Digital Controller '97 [6].

AC '97 Registers or Codec Registers

Refers to the 64-field register map defined in the AC '97 Specification.

ADC

Refers to a single Analog-to-Digital converter in the CS4202. "ADCs" refers to the stereo pair of Analog-to-Digital converters. The CS4202 ADCs have 18-bit resolution.

Codec

Refers to the chip containing the ADCs, DACs, and analog mixer. In this data sheet, the codec is the CS4202.

DAC

Refers to a single Digital-to-Analog converter in the CS4202. "DACs" refers to the stereo pair of Digital-to-Analog converters. The CS4202 DACs have 20-bit resolution.

dB FS A

dB FS is defined as dB relative to full-scale. The "A" indicates an A weighting filter was used.

Differential Nonlinearity

The worst case deviation from the ideal code width. Units in LSB.

Dynamic Range (DR)

DR is the ratio of the RMS full-scale signal level divided by the RMS sum of the noise floor, in the presence of a signal, available at any instant in time (no change in gain settings between measurements). Measured over a 20 Hz to 20 kHz bandwidth with units in dB FS A.

FFT

Fast Fourier Transform.

Frequency Response (FR)

FR is the deviation in signal level verses frequency. The 0 dB reference point is 1 kHz. The amplitude corner, A_c , lists the maximum deviation in amplitude above and below the 1 kHz reference point. The listed minimum and maximum frequencies are guaranteed to be within the A_c from minimum frequency to maximum frequency inclusive.

Fs

Sampling Frequency.

Interchannel Gain Mismatch

For the ADCs, the difference in input voltage to get an equal code on both channels. For the DACs, the difference in output voltages for each channel when both channels are fed the same code. Units are in dB.

Interchannel Isolation

The amount of 1 kHz signal present on the output of the grounded AC-coupled line input channel with 1 kHz, 0 dB, signal present on the other line input channel. Units are in dB.

Line-level

Refers to a consumer equipment compatible, voltage driven interface. The term implies a low driver impedance and a minimum 10 k Ω load impedance.

PATHS

A-D: Analog in, through the ADCs, onto the serial link.

D-A: Serial interface inputs through the DACs to the analog output.

A-A: Analog in to Analog out (analog mixer).

PC 99

Refers to the *PC 99 System Design Guide* published by the Microsoft® Corporation [7].

PC 2001

Refers to the *PC 2001 System Design Guide* published by the Microsoft® Corporation [8].

PLL

Phase Lock Loop. Circuitry for generating a desired clock from an external clock source.

Resolution

The number of bits in the output words to the DACs, and in the input words to the ADCs.

Signal to Noise Ratio (SNR)

SNR, similar to DR, is the ratio of an arbitrary sinusoidal input signal to the RMS sum of the noise floor, in the presence of a signal. It is measured over a 20 Hz to 20 kHz bandwidth with units in dB.

S/PDIF

Sony/Phillips Digital Interface. This interface was established as a means of digitally interconnecting consumer audio equipment. The documentation for S/PDIF has been superseded by the IEC-958 consumer digital interface document.

SRC

Sample Rate Converter. Converts data derived at one sample rate to a differing sample rate. The CS4202 operates at a fixed sample frequency of 48 kHz. The internal sample rate converters are used to convert digital audio streams playing back at other frequencies to 48 kHz.

Total Harmonic Distortion plus Noise (THD+N)

THD+N is the ratio of the RMS sum of all non-fundamental frequency components, divided by the RMS full-scale signal level. It is tested using a -3 dB FS input signal and is measured over a 20 Hz to 20 kHz bandwidth with units in dB FS.

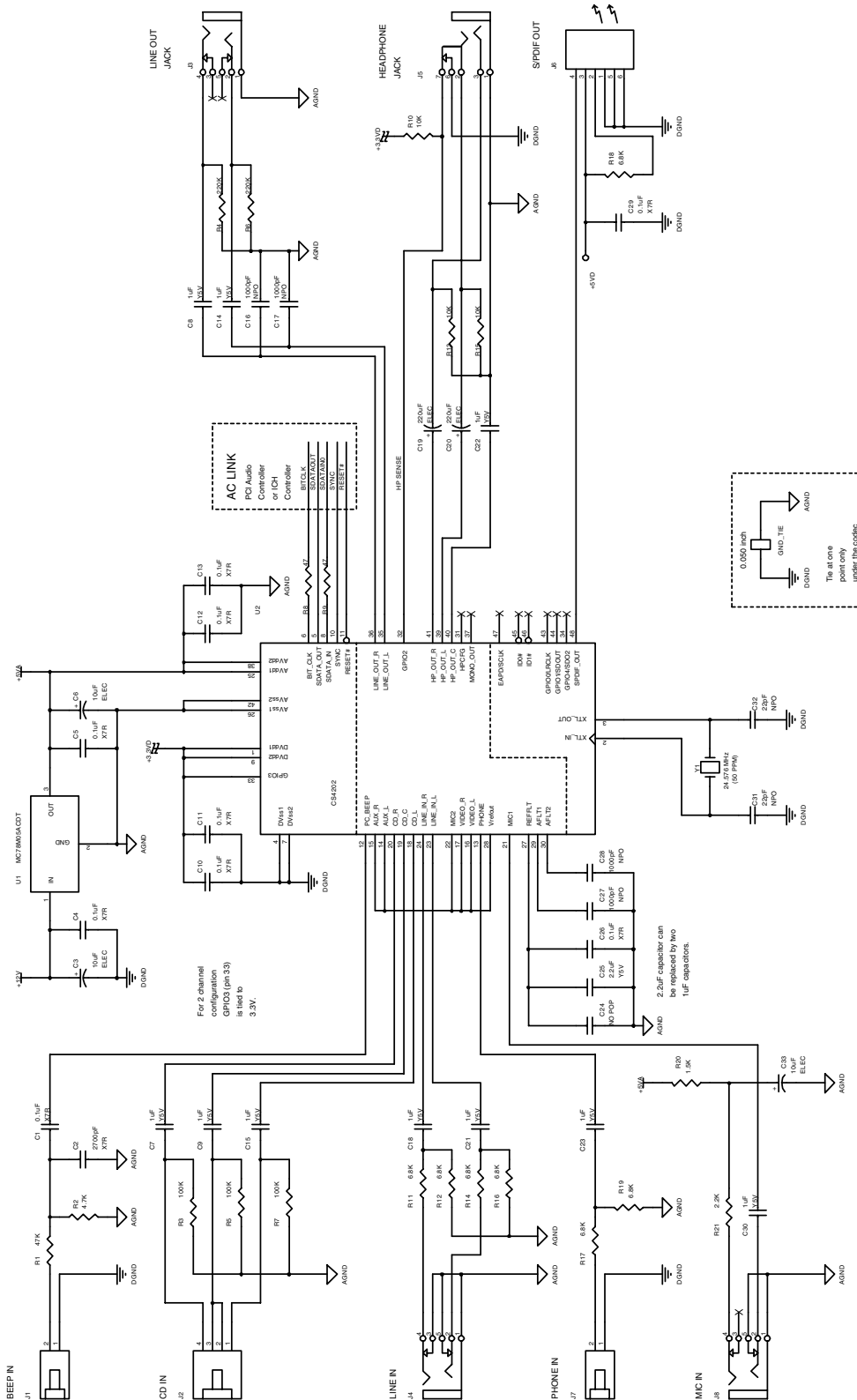
14. REFERENCE DESIGN

Figure 28. CS4202 Reference Design

15. REFERENCES

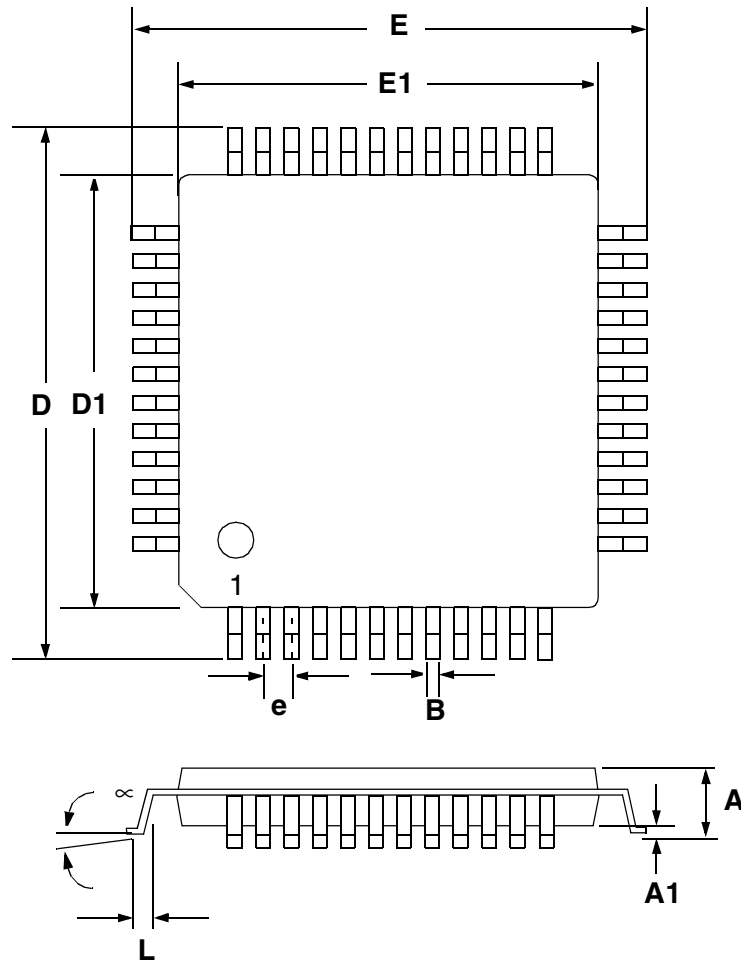
- 1) Cirrus Logic, Audio Quality Measurement Specification, Version 1.0, 1997
<http://www.cirrus.com/products/papers/meas/meas.html>
- 2) Cirrus Logic, AN18: Layout and Design Rules for Data Converters and Other Mixed Signal Devices, Version 6.0, February 1998
- 3) Cirrus Logic, AN22: Overview of Digital Audio Interface Data Structures, Version 2.0, February 1998
- 4) Cirrus Logic, AN134: AES and S/PDIF Recommended Transformers, Version 2, April 1999
- 5) Cirrus Logic, AN165: CS4297A/CS4299 EMI Reduction Techniques, Version 1.0, September 1999
- 6) Intel®, Audio Codec '97 Component Specification, Revision 2.2, September 2000
<http://developer.intel.com/ial/scalableplatforms/audio/index.htm>
- 7) Microsoft®, PC 99 System Design Guide, Version 1.0, July 1999
<http://www.microsoft.com/hwdev/desguid/>
- 8) Microsoft®, PC 2001 System Design Guide, Version 1.0, November 2000
<http://www.pcdesguide.org/pc2001/default.htm>
- 9) Intel® 82801AA (ICH) and 82801AB (ICH0) I/O Controller Hub, June 1999
<http://developer.intel.com/design/chipsets/datashts/290655.htm>
- 10) Intel® 82801BA (ICH2) I/O Controller Hub, October 2000
<http://developer.intel.com/design/chipsets/datashts/290687.htm>
- 11) Intel® 82801CAM (ICH3-M) I/O Controller Hub, July 2001
<http://developer.intel.com/design/chipsets/datashts/290716.htm>

16. PACKAGE DIMENSIONS
48L LQFP PACKAGE DRAWING

DIM	INCHES			MILLIMETERS		
	MIN	NOM	MAX	MIN	NOM	MAX
A	---	0.055	0.063	---	1.40	1.60
A1	0.002	0.004	0.006	0.05	0.10	0.15
B	0.007	0.009	0.011	0.17	0.22	0.27
D	0.343	0.354	0.366	8.70	9.0 BSC	9.30
D1	0.272	0.28	0.280	6.90	7.0 BSC	7.10
E	0.343	0.354	0.366	8.70	9.0 BSC	9.30
E1	0.272	0.28	0.280	6.90	7.0 BSC	7.10
e*	0.016	0.020	0.024	0.40	0.50 BSC	0.60
L	0.018	0.24	0.030	0.45	0.60	0.75
∞	0.000°	4°	7.000°	0.00°	4°	7.00°

* Nominal pin pitch is 0.50 mm

Controlling dimension is mm.

JEDEC Designation: MS022

• **Notes** •



CIRRUS LOGIC[®]

This datasheet has been downloaded from:

www.DatasheetCatalog.com

Datasheets for electronic components.



LittleDiode supplies new, hard to find or obsolete electronic components and semiconductors all over the world.

With over two million different components listed you are sure to find the part you need.

Feel free to visit us today at our online store:

LittleDiode.com

Looking forward to providing you with the best possible service.