

ANALOG CHARACTERISTICS ($T_A = 25^\circ\text{C}$; $V_A, V_D = +5\text{V}$; Full Scale Input Sine wave, 997 Hz; $F_s = 48\text{ kHz}$; Measurement Bandwidth is 20 Hz to 20 kHz; Local components as shown in "Recommended Connection Diagram"; SPI mode, Format 0, unless otherwise specified.)

Parameter	Symbol	Min	Typ	Max	Units	
Analog Input Characteristics						
ADC Resolution		-	-	20	Bits	
Total Harmonic Distortion	THD		0.003	-	%	
Dynamic Range	(A-weighted): (unweighted):	TBD TBD	99 96	- -	dB dB	
Total Harmonic Distortion + Noise	-1 dB (Note 1)	THD+N	-	-90	TBD	dB
Interchannel Isolation	(1 kHz)		-	90	-	dB
Interchannel Gain Mismatch			-	0.1	-	dB
Offset Error	(with High Pass Filter) (HPF defeated with CAL)		- -	- TBD	0 -	LSB LSB
Full Scale Input Voltage (Differential)			1.9	2.0	2.1	V _{rms}
Gain Drift			-	100	-	ppm/°C
Input Resistance			10	-	-	kΩ
Input Capacitance			-	-	15	pF
Common Mode Input Voltage			-	2.3	-	V
A/D Decimation Filter Characteristics						
Passband	(Note 2)		0	-	21.8	kHz
Passband Ripple			-	-	±0.01	dB
Stopband	(Note 2)		30	-	6114	kHz
Stopband Attenuation	(Note 3)		80	-	-	dB
Group Delay ($F_s = \text{Output Sample Rate}$)	(Note 4)	t_{gd}	-	15/ F_s	-	s
Group Delay Variation vs. Frequency		Δt_{gd}	-	-	0	μs
High Pass Filter Characteristics						
Frequency Response:	-3 dB (Note 2) -0.1 dB		- -	3.7 20	- -	Hz Hz
Phase Deviation	@ 20 Hz (Note 2)		-	10	-	Degree
Passband Ripple			-	-	0	dB

- Notes:
1. Referenced to typical full-scale differential input voltage (2 V_{rms})
 2. Filter characteristics scale with output sample rate. For output sample rates, F_s , other than 48 kHz, the 0.01 dB passband edge is $0.4535 \times F_s$ and the stopband edge is $0.625 \times F_s$.
 3. The analog modulator samples the input at 6.144 MHz for an F_s equal to 48 kHz. There is no rejection of input signals which are multiples of the sampling frequency ($n \times 6.144\text{ MHz} \pm 21.8\text{ kHz}$ where $n = 0, 1, 2, 3, \dots$).
 4. Group delay for $F_s = 48\text{ kHz}$, $t_{gd} = 15/48\text{ kHz} = 312\mu\text{s}$

* Parameter definitions are given at the end of this data sheet.

Specifications are subject to change without notice.

ANALOG CHARACTERISTICS (Continued)

Parameter	Symbol	Min	Typ	Max	Units
Analog Output Characteristics - Minimum Attenuation, 10 k Ω , 100 pF load; unless otherwise specified.					
DAC Resolution		-	-	20	Bits
Signal-to-Noise, Idle-Channel Noise (DAC muted, A-weighted)		TBD	110	-	dB
Dynamic Range (DAC not muted, A-weighted)		TBD	99	-	dB
		TBD	96	-	dB
Total Harmonic Distortion	THD	-	0.003	-	%
Total Harmonic Distortion + Noise	THD+N	-	-88	TBD	dB
Interchannel Isolation (1kHz)		-	90	-	dB
Interchannel Gain Mismatch		-	0.1	-	dB
Attenuation Step Size (All Outputs)		0.35	0.5	0.65	dB
Programmable Output Attenuation Span		110	113.5	-	dB
Differential Offset Voltage		-	± 10	-	mV
Common Mode Output Voltage		-	2.3	-	V
Full Scale Output Voltage		1.9	2.0	2.1	V _{rms}
Gain Drift		-	100	-	ppm/ $^{\circ}$ C
Out-of-Band Energy (Fs/2 to 2Fs)		-	-60	-	dBFS
Analog Output Load	Resistance: Capacitance:	10	-	-	k Ω
		-	-	100	pF
Combined Digital and Analog Filter Characteristics					
Frequency Response 10 Hz to 20 kHz		-	± 0.1	-	dB
Deviation from Linear Phase		-	± 0.5	-	Degrees
Passband: to 0.01 dB corner (Notes 5,6)		0	-	21.8	kHz
Passband Ripple (Note 6)		-	-	± 0.01	dB
Stopband (Notes 5,6)		26.2	-	-	kHz
Stopband Attenuation (Notes 7)		70	-	-	dB
Group Delay (Fs = Input Word Rate)	t _{gd}	-	16 / Fs	-	s
Power Supply					
Power Supply Current	VA	-	30	TBD	mA
	VD	-	20	TBD	mA
	Total Power Down	-	0.2	-	mA
Power Supply Rejection Ratio (1 kHz, 10 mV _{rms})		-	50	-	dB

Notes: 5. The passband and stopband edges scale with frequency. For input word rates, Fs, other than 48 kHz, the 0.01 dB passband edge is 0.4535x F_s and the stopband edge is 0.5465x F_s .

6. Digital filter characteristics.

7. Measurement bandwidth is 10Hz to 3Fs.

Specifications are subject to change without notice

SWITCHING CHARACTERISTICS ($T_A = 25^\circ\text{C}$; $V_A, V_D = +5\text{V} \pm 5\%$, outputs loaded with 30pF)

Parameter	Symbol	Min	Typ	Max	Units
Audio ADC's & DAC's Sample Rate	F_s	4	-	50	kHz
MCLK Frequency (MCLK = 256, 384, or 512 F_s)		1.024	-	26	MHz
MCLK Pulse Width High	MCLK = 512 F_s	10	-	-	ns
	MCLK = 384 F_s	21	-	-	ns
	MCLK = 256 F_s	31	-	-	ns
MCLK Pulse Width Low	MCLK = 512 F_s	10	-	-	ns
	MCLK = 384 F_s	21	-	-	ns
	MCLK = 256 F_s	31	-	-	ns
MCLK Jitter Tolerance		-	500	-	ps RMS
RST Low Time (Note 8)		10	-	-	ms
SCLK Falling edge to SDOUT output valid (DSCK=0)	t_{dpd}	-	-	$\frac{1}{(384)F_s} + 20$	ns
LRCK edge to MSB valid	t_{lrpd}	-	-	25	ns
SDIN Setup Time Before SCLK Rising Edge (DSCK=0)	t_{ds}	-	-	25	ns
SDIN Hold Time After SCLK Rising Edge (DSCK=0)	t_{dh}	-	-	25	ns
SCLK Period	t_{sckw}	$\frac{1}{(128)F_s}$	-	-	ns
SCLK High Time	t_{sckh}	40	-	-	ns
SCLK Low Time	t_{sckl}	40	-	-	ns
SCLK Rising to LRCK Edge (DSCK=0)	t_{lrckd}	20	-	-	ns
LRCK Edge to SCLK Rising (DSCK=0)	t_{lrcks}	40	-	-	ns

Notes: 8. After powering up the CS4222, PDN should be held low for 10 ms to allow the power supply to settle.

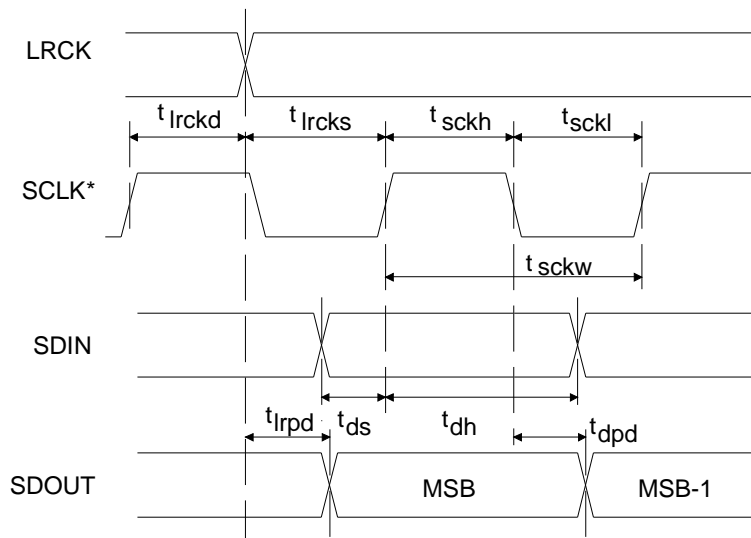

*SCLK shown for DSCK = 0, SCLK inverted for DSCK = 1.

Serial Audio Port Data I/O timing

SWITCHING CHARACTERISTICS - CONTROL PORT

($T_A = 25^\circ\text{C}$ VD, $V_A = 5\text{V} \pm 5\%$; Inputs: logic 0 = DGND, logic 1 = VD, $C_L = 30\text{pF}$)

Parameter	Symbol	Min	Max	Units
SPI Mode ($\overline{\text{SPI}}/\text{I}^2\text{C} = 0$)				
CCLK Clock Frequency	f_{sck}	-	6	MHz
RST rising edge to CS falling	t_{srs}	500	-	ns
CCLK edge to CS falling (Note 9)	t_{spl}	500	-	ns
CS High Time Between Transmissions	t_{csh}	1.0	-	μs
CS Falling to CCLK Edge	t_{css}	20	-	ns
CCLK Low Time	t_{scl}	66	-	ns
CCLK High Time	t_{sch}	66	-	ns
CDIN to CCLK Rising Setup Time	t_{dsu}	40	-	ns
CCLK Rising to DATA Hold Time (Note 10)	t_{dh}	15	-	ns
Rise Time of CCLK and CDIN (Note 11)	t_{r2}	-	100	ns
Fall Time of CCLK and CDIN (Note 11)	t_{f2}	-	100	ns

Notes: 9. t_{spl} only needed before first falling edge of $\overline{\text{CS}}$ after $\overline{\text{RST}}$ rising edge.
 $t_{\text{spl}} = 0$ at all other times.

10. Data must be held for sufficient time to bridge the transition time of CCLK.

11. For $F_{\text{sck}} < 1 \text{ MHz}$

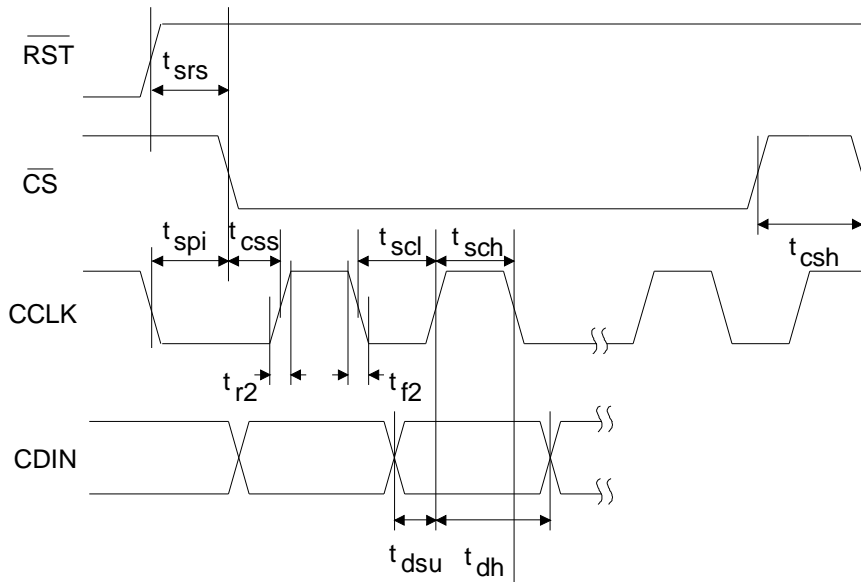

SWITCHING CHARACTERISTICS - CONTROL PORT

(T_A = 25°C; V_D, V_A = 5V±5%; Inputs: logic 0 = DGND, logic 1 = VD, C_L = 30pF)

Parameter	Symbol	Min	Max	Units
I²C[®] Mode (SPI/I²C = 1) (Note 12)				
SCL Clock Frequency	f _{scl}	-	100	kHz
RST Rising Edge to Start	t _{irs}	500	-	ns
Bus Free Time Between Transmissions	t _{buf}	4.7	-	μs
Start Condition Hold Time (prior to first clock pulse)	t _{hdst}	4.0	-	μs
Clock Low Time	t _{low}	4.7	-	μs
Clock High Time	t _{high}	4.0	-	μs
Setup Time for Repeated Start Condition	t _{sust}	4.7	-	μs
SDA Hold Time from SCL Falling (Note 13)	t _{hdd}	0	-	μs
SDA Setup Time to SCL Rising	t _{sud}	250	-	ns
Rise Time of Both SDA and SCL Lines	t _r	-	1	μs
Fall Time of Both SDA and SCL Lines	t _f	-	300	ns
Setup Time for Stop Condition	t _{susp}	4.7	-	μs

- Notes: 12. Use of the I²C[®] bus interface requires a license from Philips.
 I²C[®] is a registered trademark of Philips Semiconductors.
 13. Data must be held for sufficient time to bridge the 300ns transition time of SCL.

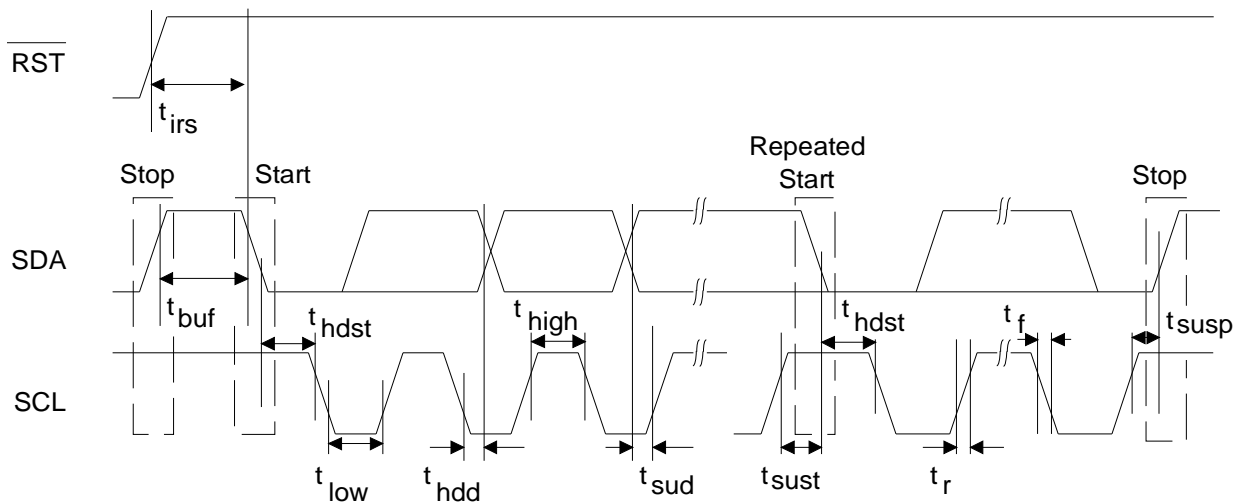

ABSOLUTE MAXIMUM RATINGS (AGND, DGND = 0V, all voltages with respect to 0V.)

Parameter	Symbol	Min	Typ	Max	Units	
Power Supplies	Digital	VD	-0.3	-	6.0	V
	Analog	VA	-0.3	-	6.0	V
Input Current (Note 14)		-	-	±10	mA	
Analog Input Voltage (Note 15)		-0.7	-	VA+0.7	V	
Digital Input Voltage (Note 15)		-0.7	-	VD+0.7	V	
Ambient Temperature (Power Applied)		-55	-	+125	°C	
Storage Temperature		-65	-	+150	°C	

Warning: Operation at or beyond these limits may result in permanent damage to the device. Normal operation is not guaranteed at these extremes.

Note: 14. Any pin except supplies. Transient currents of up to ±100mA on the analog input pins will not cause SCR latch-up.

15. The maximum over or under voltage is limited by the input current.

RECOMMENDED OPERATING CONDITIONS (AGND, DGND = 0V, all voltages with respect to 0V.)

Parameter	Symbol	Min	Typ	Max	Units	
Power Supplies	Digital	VD	4.75	5.0	5.25	V
	Analog	VA	4.75	5.0	5.25	V
	VA - VD	-	-	0.4	V	
Operating Ambient Temperature	T _A	-10	25	70	°C	

DIGITAL CHARACTERISTICS (T_A = 25 °C; V_A, V_D = 5V ± 5%)

Parameter	Symbol	Min	Typ	Max	Units
High-level Input Voltage	V _{IH}	2.8	-	VD+0.3	V
Low-level Input Voltage	V _{IL}	-0.3	-	1.0	V
High-level Output Voltage at I ₀ = -2.0 mA	V _{OH}	VD-1.0	-	-	V
Low-level Output Voltage at I ₀ = 2.0 mA	V _{OL}	-	-	0.4	V
Input Leakage Current (Digital Inputs)		-	-	10	µA
Output Leakage Current (High Impedance Digital Outputs)		-	-	10	µA

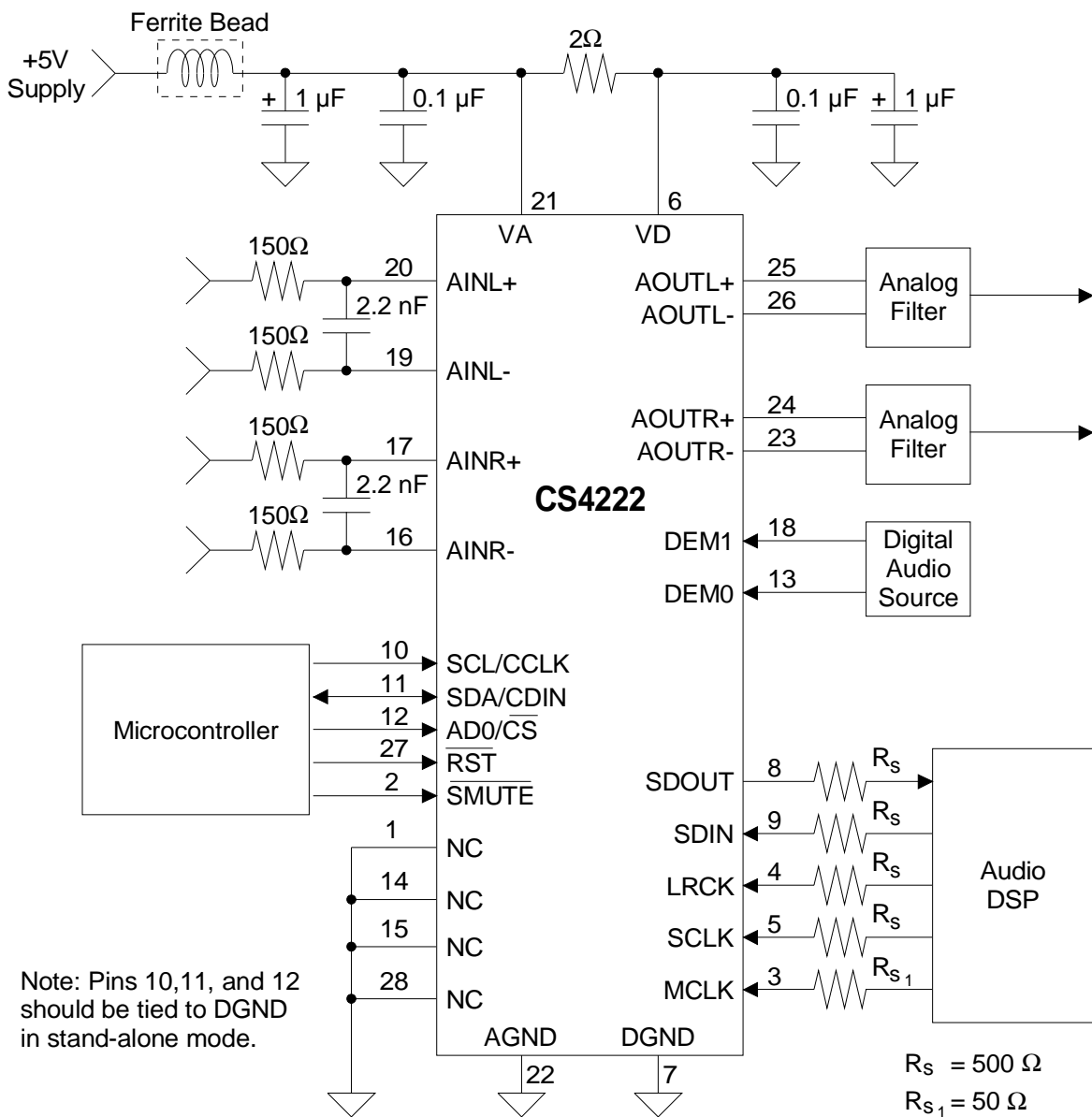

Figure 1. Recommended Connection Diagram
 (Also see recommended layout diagram, Figure 10)

FUNCTIONAL DESCRIPTION

Overview

The CS4222 has 2 channels of 20-bit analog-to-digital conversion and 2 channels of 20-bit digital-to-analog conversion. All ADCs and DACs are delta-sigma converters. The DAC outputs have adjustable output attenuation implemented in 0.5 dB step resolution. The device also includes a soft mute function and digital de-emphasis for 32, 44.1, and 48 kHz.

Digital audio data for the DACs and from the ADCs is communicated over separate serial ports. This allows concurrent writing to and reading from the device. Control for the functions available on the CS4222 are communicated over a serial microcontroller interface. Figure 1 shows the recommended connection diagram for the CS4222.

The device can be operated with or without the control port interface. Additional functions are available when the control port interface is used as outlined in Table 1.

Control Port	Stand-alone
Volume control	-
Adjustable Mute ramp rate	Fixed Mute ramp rate
Enable zero crossing detect	Disabled
Disable mute on zero input	Enabled
De-emphasis	De-emphasis
Mute DAC outputs	Mute DAC outputs
ADC Input Peak Level Detect	-
16, 18, 20 bit Interface	20 bit I ² S Interface
Individual ADC/DAC power down	Codec power down
Cal on command	Cal on power-up
High pass enable/disable	High pass enabled

Table 1. Control Port vs. Stand-alone

Analog Inputs

Line Level Inputs

AINR-, AINR+, AINL-, and AINL+ are the differential line level input pins (See Figure 1). Figure 2 shows an AC coupled optional input buffer which combines level shifting with single-ended to differential conversion. Analog inputs must be DC coupled into the CS4222 with a 2.3V common mode input voltage. Any DC off-

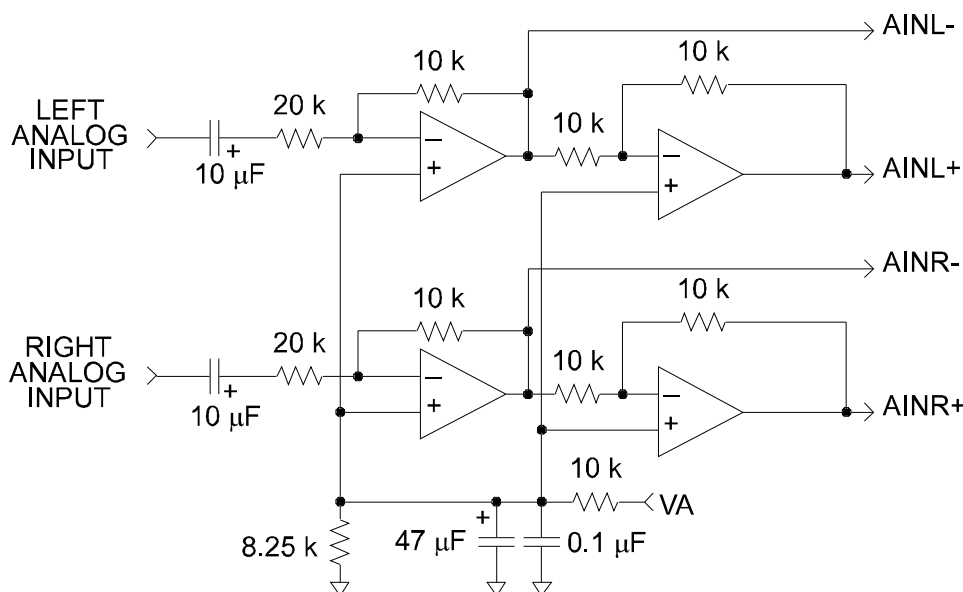

Figure 2. Optional Line Input Buffer

set at the input to the CS4222 will be removed by the internal high-pass filters. See Figure 3 for the differential input signal description. The ADC outputs may be muted (set to zero) by writing the ADMR and ADML bits, and the ADC can be independently powered down using the PDAD bit. ADMR, ADML, and PDAD are all located in the ADC control byte (#1).

Input Level Monitoring

The CS4222 includes independent Peak Input Level Monitoring for each channel. The analog-to-digital converter continually monitors the peak digital signal for both channels, prior to the digital limiter, and records these values in the LVL2-0 (left channel) and LVR2-0 (right channel) bits in the Converter Status Report Byte (#6). These bits indicate whether the input level is clipping, -1 to -6 dB from full scale in 1 dB resolution, or below -6 dB from full scale. The LVL/LVR bits are "sticky" bits and are reset to zero when read.

High Pass Filter

The operational amplifiers in the input circuitry driving the CS4222 may generate a small DC offset into the A/D converter. The CS4222 includes a high pass filter after the decimator to remove any DC offset which could result in recording a DC level, possibly yielding "clicks" when switching between devices in a multichannel system. The characteristics of this first-order high pass filter are outlined below for Fs equal to 48 kHz. The filter response scales linearly with sample rate. The high pass filter may be defeated independently for the left and right channels by writing HPDR and HPDL in the ADC control byte (#1).

Frequency Response	-3dB @ 3.7 Hz -0.1 dB @ 20 Hz
Phase Deviation	10 degrees @ 20 Hz
Passband Ripple	None

Table 2. High Pass Filter Characteristics

Analog Outputs

Line Level Outputs

The CS4222 contains an on-chip buffer amplifier producing differential outputs capable of driving 10 kΩ loads. Each output (AOUTL+, AOUTL-, AOUTR+, AOUTR-) will produce a nominal 2.83 Vpp (1 Vrms) output with a 2.3 volt common mode for a full scale digital input. This is equivalent to a 5.66 Vpp (2 Vrms) differential signal as shown in Figure 3. The recommended off-chip analog filter is either a 2nd order Butterworth or a 3rd order Butterworth, if greater out-of-band noise filtering is desired. The CS4222 DAC interpolation filter has been pre-compensated for an external 2nd order Butterworth filter with a 3dB corner at Fs, or a 3rd order Butterworth filter with a 3dB corner at 0.75 Fs to provide a flat frequency response and linear phase over the passband (see Figure 4 for Fs = 48 kHz). If the recommended filter is not used, small frequency response magnitude and phase errors will occur. In addition to providing out-of-band noise attenuation, the output filters shown in Figure 4 provide differential to single-ended conversion.

The DACs can be powered down using the PDDA bit in the DAC control register (#2).

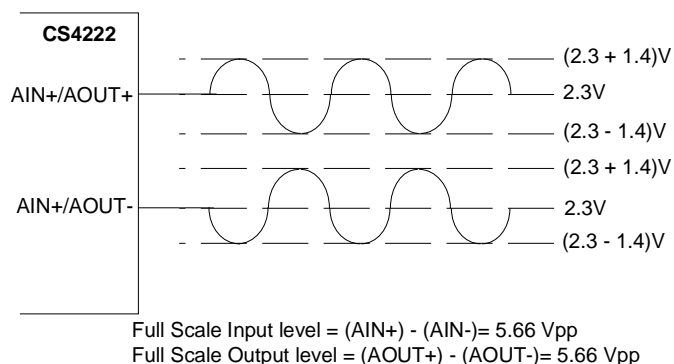

Figure 3. Full Scale Input/Output Voltage

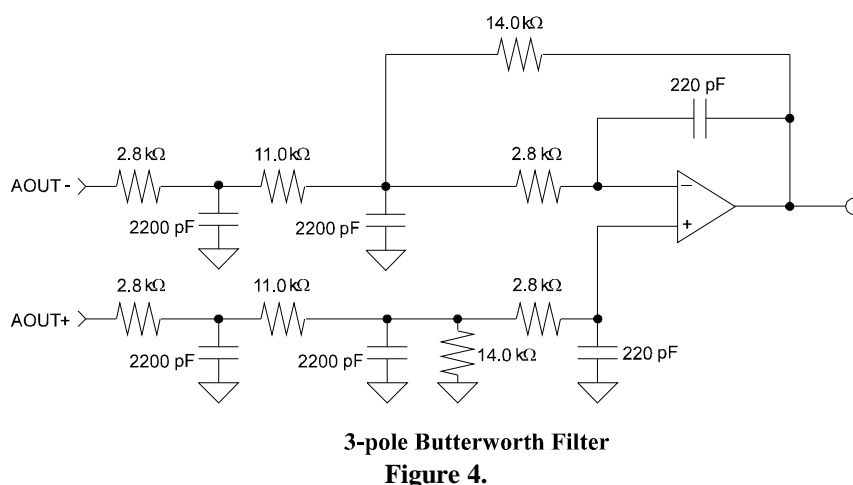
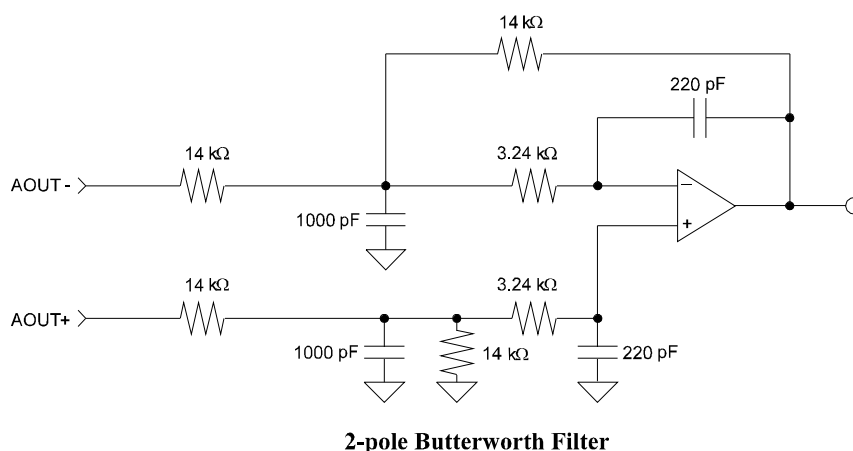

Figure 4.

Analog/Digital Volume Control - Control Port Mode Only

The DAC outputs are each routed through an attenuator which is adjustable in 0.5 dB steps. Output attenuation is available through the Output Attenuator Data Bytes (#3 & #4). Level changes are implemented with an analog volume control until the residual output noise is equal to the noise floor in the mute state at which point volume changes are performed digitally. This technique is superior to purely digital volume control techniques as the noise is attenuated by the same amount as the signal, thus preserving dynamic range (see Figure 5).

The CS4222 implements a "soft" volume control whereby level changes are achieved by ramping

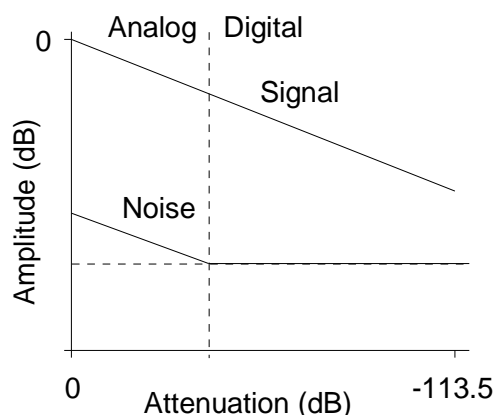

Figure 5. Hybrid Analog/Digital Attenuation

from the current level to the new level in 0.5 dB steps. The default rate of volume change is 8 LRCK cycles for each 0.5 dB step (equivalent to 647 μs at Fs = 48 kHz). The rate of volume

change is adjustable to 4, 16, or 32 LRCK cycles with the RMP1/0 bits in the DAC control byte (#2).

"Soft" volume control may be disabled through the SOFT bit in the DAC bit Control Byte (#2). When "soft" volume control is defeated, level changes step from the current level to the new level in a single step. The volume change takes effect on a zero crossing to minimize audible artifacts. If there is no zero crossing, then the requested level change will occur after a time-out period between 512 and 1024 sample periods (10.7 ms to 21.3 ms at 48 kHz sample rate). There is a separate zero crossing detector for each channel. ACCR and ACCL bits in the Converter Status Report Byte (#6) give feedback on when a volume control change has taken effect for the right and left channel. This bit goes high when a new setting is loaded and returns low when it has taken effect.

Soft Mute/Mute on Zero Input Data

Muting can be achieved via hardware or software control. Soft mute can be achieved by lowering the SMUTE pin at which point the output level will ramp down in 0.5 dB steps to a muted state. Upon returning the SMUTE pin high, the output will ramp up to the volume control setting in the Output Attenuator Data Bytes (#3 & #4). "Soft" mute may be disabled through the SOFT bit in the DAC Control Byte (#2). When "soft" mute is defeated, muting occurs on zero crossings or after a time-out period, similar to the volume control changes.

Under software control, each output can be independently muted via mute control bits, MUTR and MUTL, in the DAC Control Byte (#2). Soft mute or zero crossing mute will be implemented depending on the state of the SOFT bit in the DAC Control Byte (#2).

Muting on consecutive zero input data is also provided where all DAC outputs will mute if

they receive between 512 and 1024 consecutive zeros (or -1 code). Detection and muting is done independently for left and right channels. A single non-zero value will immediately unmute the DAC output. This feature is enabled on power-up, and it may be disabled with the MUTC bit in the DAC Control Byte (#2).

Master Clock Generation

The Master Clock, MCLK, is used to operate the digital filters and the delta-sigma modulator. MCLK must be either 256x, 384x, or 512x the desired Input Sample Rate, Fs. Fs is the frequency at which digital audio samples for each channel are input to the DAC or output from the ADC and is equal to the LRCK frequency. The MCLK to LRCK frequency ratio is detected automatically during the initialization sequence by counting the number of MCLK transitions during a single LRCK period. Internal dividers are then set to generate the proper clocks for the digital filters, delta-sigma modulators and switched-capacitor filter. Table 3 illustrates the standard audio sample rates and the required MCLK frequencies. If MCLK stops for 10µs, the CS4222 will enter a power down state until the clock returns. The control port registers will maintain their current settings. It is required to have SCLK and LRCK derived from the master clock.

Fs (kHz)	MCLK (MHz)		
	256x	384x	512x
32	8.1920	12.2880	16.3840
44.1	11.2896	16.9344	22.5792
48	12.2880	18.4320	24.5760

Table 3. Common Clock Frequencies

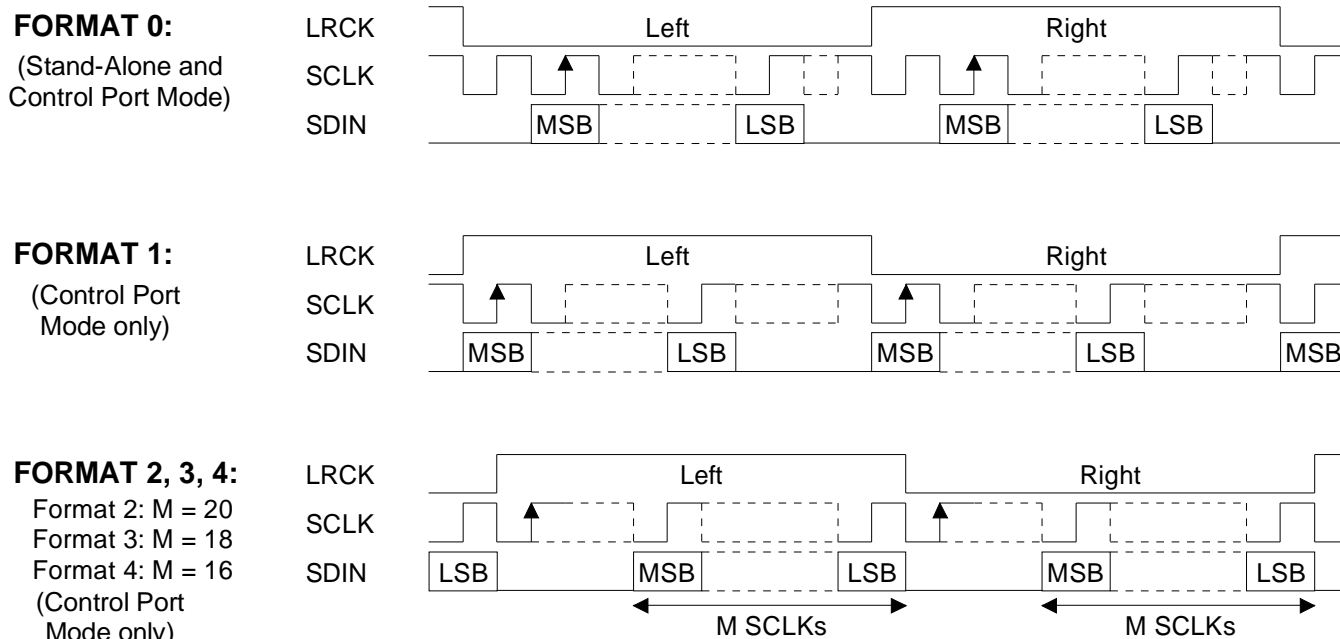

Note: SCLK shown for DSCK = 0. SCLK inverted for DSCK = 1.

Figure 6. Audio DSP Data Input Formats.

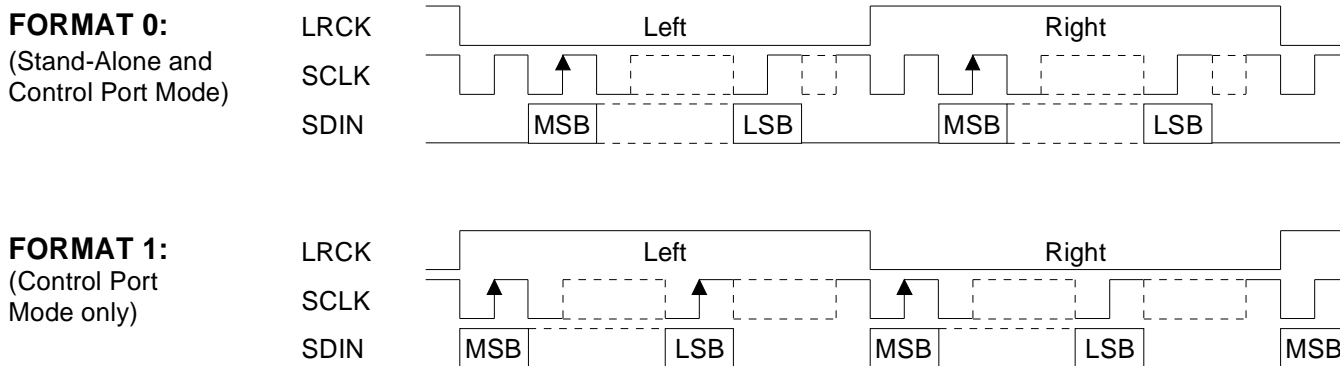

Note: SCLK shown for DSCK = 0. SCLK inverted for DSCK = 1.

Figure 7. Audio DSP Port Data Output Formats.

Serial Audio Data Interface

Serial Audio Interface Signals

The serial interface clock, SCLK, is used for transmitting and receiving audio data. The active edge of SCLK is chosen by setting the DSCK bit in the DSP Port Mode Byte (#6); the default upon power-up is that data is valid on the rising edge for both input and output. SCLK is an input from an external source and at least 20 SCLK's per half period of LRCK are required for proper operation.

The Left/Right clock (LRCK) is used to indicate left and right data and the start of a new sample period. The frequency of LRCK must be equal to the system sample rate, Fs.

SDIN is the data input pin which drives a pair of DACs. SDOUT is the output data pin from the ADC's.

Serial Audio Interface Formats

The serial audio port supports 5 input and 2 output formats, shown in Figures 6 and 7. These formats are chosen through the DSP Port Mode Byte (#5) with the DDO and DDI2/1/0 bits. The data output format is 20 bits and may be left justified or I²S compatible depending on the state of the DDO bit. The input data format is set with the DDI bits to be left or right justified or I²S compatible. In addition, the polarity of the SCLK edge used to clock in/out data from the

CS4222 may be set via the DSCK bit in the DSP Port Mode Byte (#5). The default input and output format is I²S compatible.

Control Port Interface

The control port is used to load all the internal settings. The operation of the control port may be completely asynchronous with the audio sample rate. However, to avoid potential interference problems, the control port pins should remain static if no operation is required.

The control port has 2 modes: SPI and I²C[®], with the CS4222 operating as a slave device. If I²C operation is desired, AD0/ \overline{CS} should be tied to VD or DGND. If the CS4222 ever detects a negative transition on AD0/ \overline{CS} after power-up, SPI mode will be selected.

SPI Mode

In SPI mode, \overline{CS} is the CS4222 chip select signal, CCLK is the control port bit clock, CDIN is the input data line from the microcontroller and the chip address is 0010000. All signals are inputs and data is clocked in on the rising edge of CCLK.

Figure 8 shows the operation of the control port in SPI mode. To write to a register, bring \overline{CS} low. The first 7 bits on CDIN form the chip address, and must be 0010000. The eighth bit is a read/write indicator (R/ \overline{W}), which must be low to write. Register reading from the CS4222 is

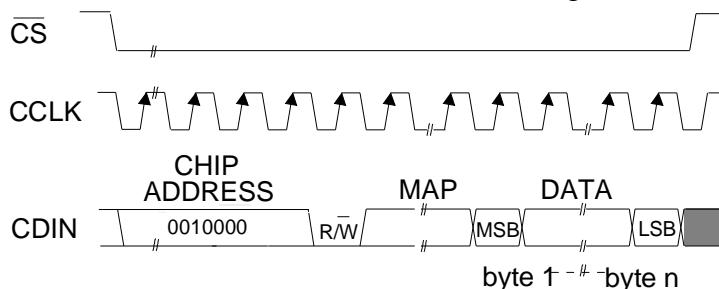

MAP = Memory Address Pointer

Figure 8. Control Port Timing, SPI mode

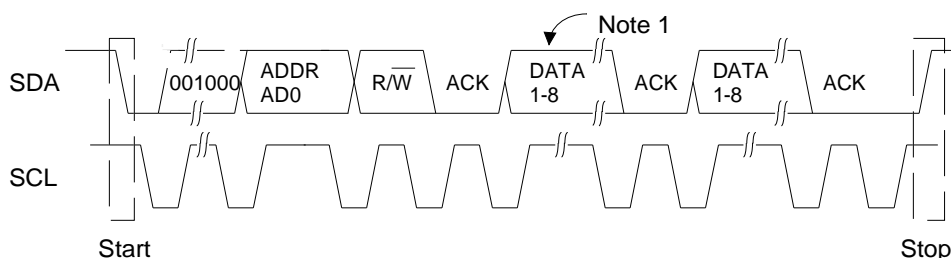

Note: If operation is a write, this byte contains the Memory Address Pointer, MAP.

Figure 9. Control Port Timing, I²C[®] Mode

not supported in the SPI mode. The next 8 bits form the Memory Address Pointer (MAP), which is set to the address of the register that is to be updated. The next 8 bits are the data which will be placed into register designated by the MAP.

The CS4222 has a MAP auto increment capability, enabled by the INCR bit in the MAP register. If INCR is a zero, then the MAP will stay constant for successive writes. If INCR is set to a 1, then MAP will auto increment after each byte is written, allowing block writes of successive registers. Register reading from the CS4222 is not supported in the SPI mode.

I²C[®] Mode

In I²C[®] mode, SDA is a bidirectional data line. Data is clocked into and out of the part by the clock, SCL, with the clock to data relationship as shown in Figure 9. There is no CS pin. Pin AD0 forms the partial chip address and should be tied to VD or DGND as desired. The upper 6 bits of the 7 bit address field must be 001000. To communicate with the CS4222 the LSB of the chip address field, which is the first byte sent to the CS4222, should match the setting of the AD0 pin. The eighth bit of the address byte is the R/W bit (high for a read, low for a write). If the operation is a write, the next byte is the Memory Address Pointer which selects the register to be read or written. If the operation is a read, the contents of the register pointed to by the Memory Address Pointer will be output. Setting the auto increment bit in MAP, allows successive

reads or writes of consecutive registers. Each byte is separated by an acknowledge bit. Use of the I²C bus[®] compatible interface requires a license from Philips. I²C bus[®] is a registered trademark of Philips Semiconductor.

Control Port Bit Definitions

All registers can be written and read in I²C mode, except the Converter Status Report Byte (#6) and the CLKE and CALP bits in the ADC control byte (#1) which are read only. SPI mode only allows for register writing. See the following bit definition tables for bit assignment information.

De-Emphasis

The CS4222 is capable of digital de-emphasis for 32, 44.1, or 48 kHz sample rates. Implementation of digital de-emphasis requires reconfiguration of the digital filter to maintain the filter response shown in Figure 10 at multiple sample rates.

De-emphasis control is achieved with the DEM1/0 pins or through the DEM2-0 bits in the DAC Control Byte (#2). The default state on power-up is de-emphasis controlled via the DEM1/0 pins (DEM2-0 bits=0). DEM1/0 pin control is defined in Table 4.

DEM 1	DEM 0	De-emphasis
0	0	32 kHz
0	1	44.1 kHz
1	0	48 kHz
1	1	OFF

Table 4. De-Emphasis filter control

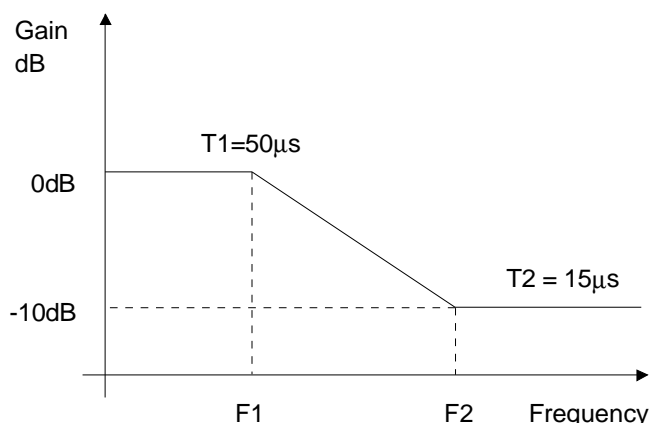

Figure 10. De-emphasis Curve.

Power-up/Reset/Power Down/Calibration

Upon power up, the user should hold $\overline{RST}=0$ for approximately 10 ms. In this state, the control port is reset to its default settings and the part remains in the power down mode. At the end of \overline{RST} , the device performs an offset calibration which lasts approximately 50 ms after which the device enters normal operation. A calibration may also be initiated via the CAL bit in the ADC Control Byte (#1). The CALP bit in the ADC Control Byte is a read only bit indicating the status of the calibration.

Reset/Power Down is achieved by lowering the \overline{RST} pin causing the part to enter power down. Once \overline{RST} goes high, the control port is functional and the desired settings should be loaded.

The CS4222 will also enter power down mode if the master clock source stops for approximately 10 µs or if the LRCK is not synchronous to the master clock. The control port will retain its current settings.

Additionally, the PDAD (ADC Control Byte #1) and PDDA (DAC Control Byte #2) bits can be used to power down the ADC's and DAC's independently. If both are set to 1, the CS4222 will power down the entire chip. The control port will retain its current settings.

The CS4222 will mute the analog outputs and enter the power down mode if the supply drops below approximately 4 volts.

Power Supply, Layout and Grounding

The CS4222 should be located on the analog ground plane along with associated analog circuitry and should be positioned near the split between ground planes (see Figure 11). Preferably, the device should also have its own power plane. The +5V supply should be connected to the CS4222 via a ferrite bead, positioned closer than 1" to the device. A single connection be-

tween the CS4222 ground and the board ground should be positioned as shown in Figure 11. See the CDB4222 evaluation board data sheet for recommended layout of the decoupling components.

ADC and DAC Filter Response Plots

Figures 12 through 17 show the overall frequency response, passband ripple and transition band for the CS4222 ADC's and DAC's.

Schematic & Layout Review Service

Confirm Optimum Schematic & Layout Before Building Your Board.

For Our Free Review Service Call Applications Engineering.



C a l l : (5 1 2) 4 4 5 - 7 2 2 2

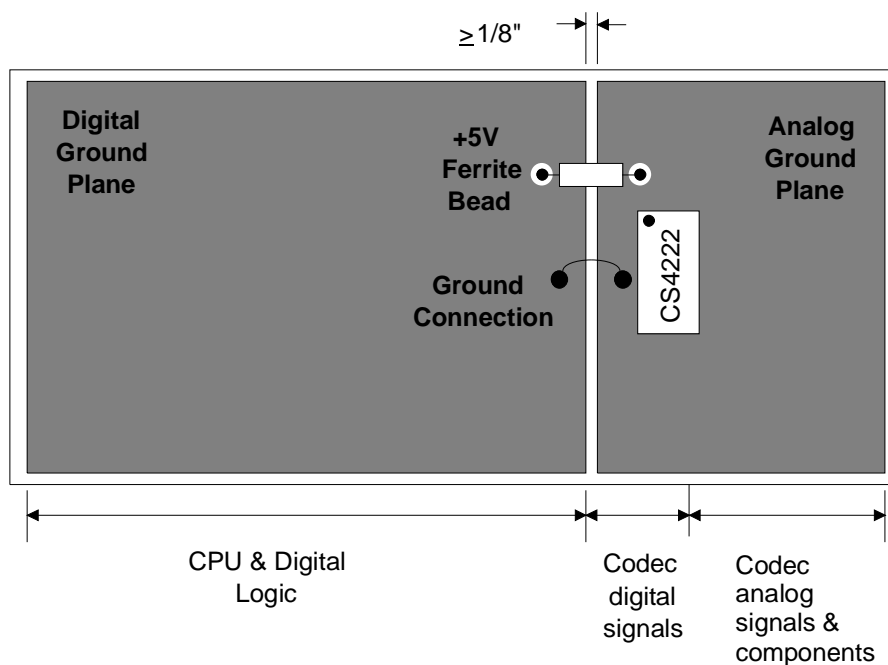

Note that the CS4222 is oriented with its digital pins towards the digital end of the board.

Figure 11. Suggested Layout Guideline (See CDB4222 Data Sheet)

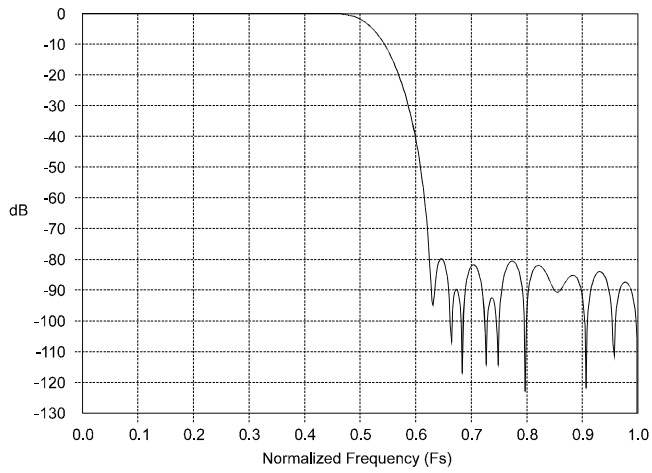

Figure 12. ADC Filter Response.

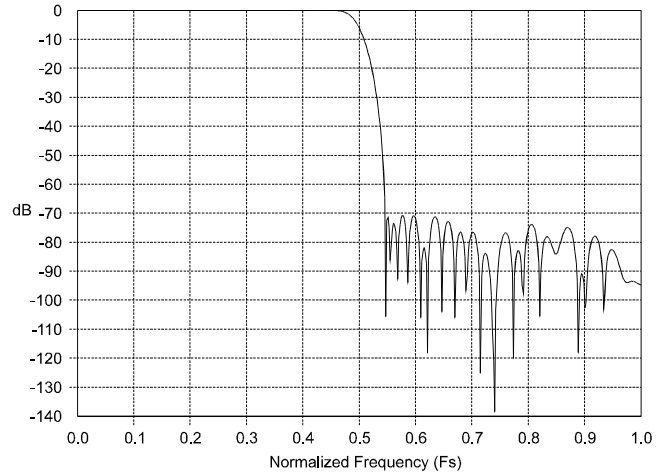

Figure 15. DAC Frequency Response.

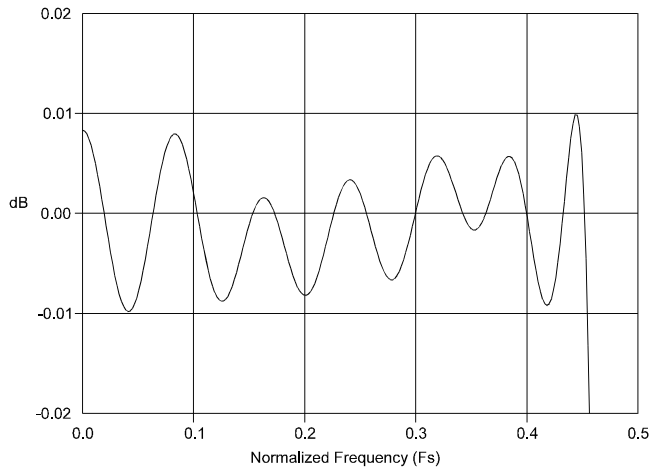

Figure 13. ADC Passband Ripple.

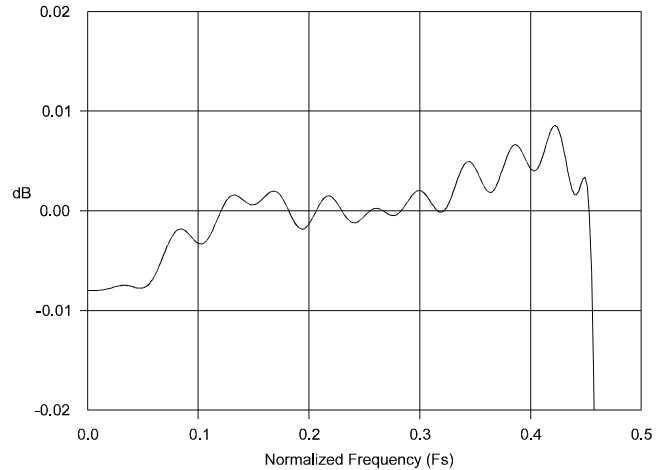

Figure 16. DAC Passband Ripple.

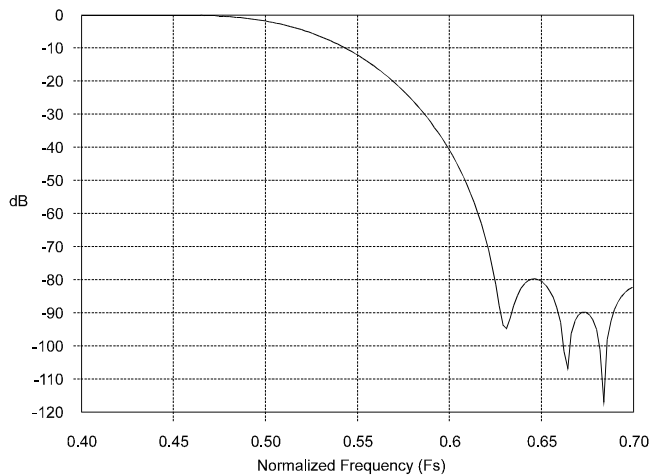

Figure 14. ADC Transition Band.

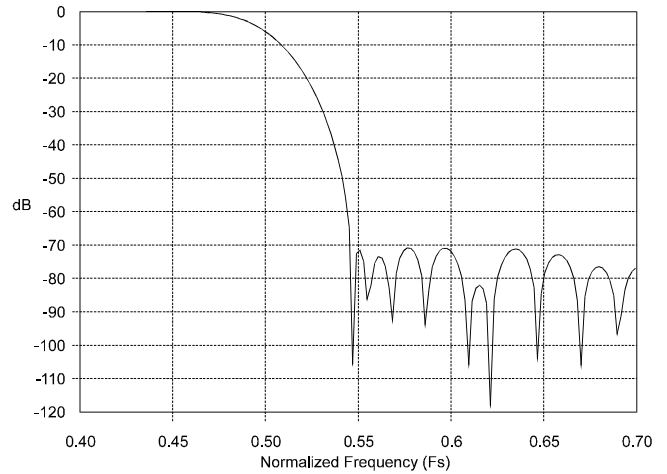

Figure 17. DAC Transition Band.

Memory Address Pointer (MAP)

B7	B6	B5	B4	B3	B2	B1	B0
INCR	0	0	0	0	MAP2	MAP1	MAP0

MAP2-MAP0 Register Pointer

INCR Auto Increment Control Bit
 0 - No auto increment
 1 - Auto increment on

This register defaults to 00h.

Reserved Byte (0)

This byte is reserved for internal use and must be set to 00h for normal operation.

This register defaults to 00h.

ADC Control Byte (1)

B7	B6	B5	B4	B3	B2	B1	B0
PDAD	HPDR	HPDL	ADMR	ADML	CAL	CALP	CLKE

PDAD Power Down ADC
 0 - Normal
 1 - Power down

HPDR-HPDL High pass filter defeat, right and left
 0 - High pass filters active
 1 - High pass filters defeated

ADMR-ADML ADC Muting, right and left
 0 - Normal
 1 - Output muted

CAL Calibration control bit
 0 - Normal operation
 1 - Rising edge initiates calibration

The following bits are read only:

CALP Calibration status
 0 - Calibration done
 1 - Calibration in progress

CLKE Clocking Error
 0 - No error
 1 - error

This register defaults to 00h.

DAC Control Byte (2)

B7	B6	B5	B4	B3	B2	B1	B0
PDDA	MUTC	MUTR	MUTL	SOFT	0	RMP1	RMP0

PDDA Power Down DAC
 0 - Normal
 1 - Power down

MUTC Controls mute on consecutive zeros function
 0 - 512 consecutive zeros will mute DAC
 1 - DAC output will not mute on zeros.

MUTR-MUTL Mute control bits
 0 - Normal output level
 1 - Selected DAC output muted

SOFT Soft Mute Control
 0 - Volume control changes, muting and mute-on-zeros occur with "ramp"
 1 - Volume control changes, muting and mute-on-zeros occur on zero crossings

RMP1-0 Soft Volume 0.5 dB step rate
 0 - 1 step per 8 LRCK's
 1 - 1 step per 4 LRCK's
 2 - 1 step per 16 LRCK's
 3 - 1 step per 32 LRCK's

This register defaults to 00h.

Output Attenuator Data Byte (3, 4)

B7	B6	B5	B4	B3	B2	B1	B0
ATT7	ATT6	ATT5	ATT4	ATT3	ATT2	ATT1	ATT0

ATT7-ATT0 Sets attenuator level
 0 - No attenuation
 227 - 113.5 dB attenuation
 >227 - DAC muted
 ATT0 represents 0.5 dB of attenuation

This register defaults to 00h.

DSP Port Mode Byte (5)

B7	B6	B5	B4	B3	B2	B1	B0
DEM2	DEM1	DEM0	DSCK	DDO	DDF2	DDF1	DDF0

DEM2-0 Selects de-emphasis control source
 0 - De-emphasis controlled by pins
 1 - 44.1 kHz de-emphasis setting
 2 - 48 kHz de-emphasis setting
 3 - 32 kHz de-emphasis setting
 4 - De-emphasis disabled
 5 - Not used
 6 - Not used
 7 - Not used

DSCK Set the polarity of clocking data
 0 - Data valid on rising edge of SCLK
 1 - Data valid on falling edge of SCLK

DDO Data output format
 0 - I²S compatible
 1 - Left justified

DDI2-DDI0 Data input format
 0 - I²S compatible
 1 - Left justified
 2 - Right justified, 20-bit
 3 - Right justified, 18-bit
 4 - Right justified, 16-bit
 5 - Not used
 6 - Not used
 7 - Not used

This register defaults to 00h.

Converter Status Report Byte (Read Only) (6)

B7	B6	B5	B4	B3	B2	B1	B0
ACCR	ACCL	LVR2	LVR1	LVR0	LVL2	LVL1	LVL0

ACCR-ACCL Acceptance bit
 0 - ATT7-0 has been accepted
 1 - New setting waiting for zero crossing

LVL2-0,LVR2-0 Left and Right ADC output level
 0 - Normal output levels
 1 - -6 dB level
 2 - -5 dB level
 3 - -4 dB level
 4 - -3 dB level
 5 - -2 dB level
 6 - -1 dB level
 7 - Clipping

LVL2-0 and LVR2-0 bits are 'sticky'. They constantly monitor the ADC output for the peak levels and hold the maximum output. They are reset to 0 when read.

This register is read only.

PIN DESCRIPTIONS

NC	1	●	28	NC
SMUTE	2		27	RST
MCLK	3		26	AOUTL-
LRCK	4		25	AOUTL+
SCLK	5		24	AOUTR+
VD	6		23	AOUTR-
DGND	7		22	AGND
SDOUT	8		21	VA
SDIN	9		20	AINL+
SCL/CCLK	10		19	AINL-
SDA/CDIN	11		18	DEM1
AD0/CS	12		17	AINR+
DEM0	13		16	AINR-
NC	14		15	NC

Power Supply
VA - Positive Analog Power, Pin 21.

Positive analog supply. Nominally +5 volts.

VD - Positive Digital Power, Pin 6.

Positive supply for the digital section. Nominally +5 volts.

AGND - Analog Ground, Pin 22.

Analog ground reference.

DGND - Digital Ground, Pin 7.

Digital ground for the digital section.

Analog Inputs
AINR-, AINR+ - Differential Right Channel Analog Input, Pins 16 and 17.

Analog input connections of the right channel differential inputs. Typically 2 V_{rms} differential (1 V_{rms} for each input pin) for a full-scale analog input signal.

AINL-, AINL+ - Differential Left Channel Analog Input, Pins 19 and 20.

Analog input connections of the left channel differential inputs. Typically 2 V_{rms} differential (1 V_{rms} for each input pin) for a full-scale analog input signal.

Analog Outputs

AOUTR-, AOUTR+ - Differential Right Channel Analog Outputs, Pins 23 and 24.

Analog output connections for the Right channel differential outputs. Nominally 2 V_{rms} (differential) for full-scale digital input signal.

AOURL-, AOURL+ - Differential Left Channel Analog Outputs, Pins 25 and 26.

Analog output connections for the Left channel differential outputs. Nominally 2 V_{rms} (differential) for full-scale digital input signal.

Digital Inputs

MCLK - Master Clock, Pin 3.

Clock source for the delta-sigma modulator sampling and digital filters. The frequency of this clock must be either 256x, 384x, or 512x F_s.

LRCK - Left/Right Clock, Pin 4.

LRCK determines which channel, left or right, is to be input/output on SDIN/SDOUT. Although the outputs for each ADC channel are transmitted at different times, Left/Right pairs represent simultaneously sampled analog inputs. LRCK is an input clock whose frequency must be equal to F_s.

SCLK - Serial Data Clock, Pin 5.

Clocks the individual bits of the serial data out from SDOUT and in from SDIN.

SDIN - Serial Data Input, Pin 9.

Two's complement MSB-first serial data of either 16, 18, or 20 bits is input on this pin. The data is clocked into the CS4222 via the SCLK clock and the channel is determined by the LRCK clock. The default interface format on power-up is an I²S compatible 20-bit interface. This may be changed by writing the control port (DSP Port Mode Byte #5).

DEM1, DEM0 - De-Emphasis Select, Pins 18 and 13.

Controls the activation of the standard 50/15 μs de-emphasis filter. 32, 44.1, or 48 kHz sample rate selection defined in Table 4.

SMUTE - Soft Mute, Pin 2.

$\overline{\text{SMUTE}}$ low activates a muting function for both the left and right channel D/A converter outputs. Soft muting is achieved by ramping down the volume in 0.5 dB steps until achieving mute if SOFT bit (DAC Control Byte #2) is set to 0 (default).

Digital Outputs

SDOUT - Serial Data Output, Pin 8.

Two's complement MSB-first serial data of 20 bits is output on this pin. The data is clocked out via the SCLK clock and the channel is determined by LRCK.

Control Port Signals

SCL/CCLK - Serial Control Interface Clock, Pin 10.

SCL/CCLK is the serial control interface clock and is used to clock control bits into and out of the CS4222. This pin should be tied to DGND in stand-alone mode.

AD0/ $\overline{\text{CS}}$ - Address Bit/Control Port Chip Select, Pin 12.

In I²C[®] mode, AD0 is a chip address bit. In SPI mode, $\overline{\text{CS}}$ is used to enable the control port interface on the CS4222. The CS4222 will enter SPI mode if a negative transition is ever seen on this pin after power up. This pin should be tied to DGND in stand-alone mode.

SDA/CDIN - Serial Control Data In, Pin 11.

SDA/CDIN is the input data line for the control port interface. This pin should be tied to DGND in stand-alone mode.

Miscellaneous Pins

$\overline{\text{RST}}$ - Reset, Pin 27.

When low, the CS4222 enters a low power mode and all internal states are reset, including the control port. When high, the control port becomes operational and normal operation will occur.

NC - No Connect, Pins 1, 14, 15 and 28

These pins are not connected internally and should be tied to DGND to minimize noise coupling.

PARAMETER DEFINITIONS

Dynamic Range

The ratio of the full scale rms value of the signal to the rms sum of all other spectral components over the specified bandwidth. Dynamic range is a signal-to-noise measurement over the specified bandwidth made with a -60dBFS signal. 60dB is then added to the resulting measurement to refer the measurement to full scale. This technique ensures that the distortion components are below the noise level and do not affect the measurement. This measurement technique has been accepted by the Audio Engineering Society, AES17-1991, and the Electronic Industries Association of Japan, EIAJ CP-307.

Total Harmonic Distortion + Noise

The ratio of the rms value of the signal to the rms sum of all other spectral components over the specified bandwidth (typically 20Hz to 20kHz), including distortion components. Expressed in decibels. ADCs are measured at -1 dBFS as suggested in AES17-1991 Annex A and DACs are measured at 0 dBFS.

Idle Channel Noise / Signal-to-Noise-Ratio

The ratio of the rms analog output level with 1kHz full scale digital input to the rms analog output level with all zeros into the digital input. Measured A-weighted over a 10Hz to 20kHz bandwidth. Units in decibels. This specification has been standardized by the Audio Engineering Society, AES17-1991, and referred to as Idle Channel Noise. This specification has also been standardized by the Electronic Industries Association of Japan, EIAJ CP-307, and referred to as Signal-to-Noise-Ratio.

Total Harmonic Distortion (THD)

THD is the ratio of the test signal amplitude to the rms sum of all the in-band harmonics of the test signal. Units in decibels.

Interchannel Isolation

A measure of crosstalk between channels. Measured for each channel at the converter's output with no signal to the input under test and a full-scale signal applied to the other channel. Units in decibels.

Frequency Response

A measure of the amplitude response variation from 20Hz to 20kHz relative to the amplitude response at 1kHz. Units in decibels.

Interchannel Gain Mismatch

For the ADCs, the difference in input voltage that generates the full scale code for each channel. For the DACs, the difference in output voltages for each channel with a full scale digital input. Units are in decibels.

Gain Error

The deviation from the nominal full scale output for a full scale input.

Gain Drift

The change in gain value with temperature. Units in ppm/°C.

Offset Error

For the ADCs, the deviation in LSB's of the output from mid-scale with the selected inputs tied to a common potential. For the DAC's, the differential output voltage with mid-scale input code. Units are in volts.

PACKAGE DIMENSIONS

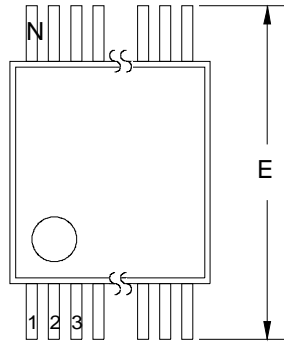

TOP VIEW

SSOP Package Dimensions

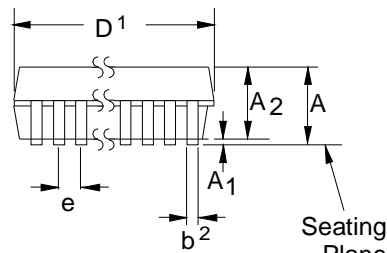

SIDE VIEW

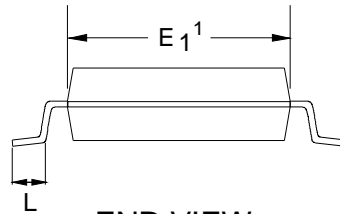

END VIEW

Notes:

- "D" and "E1" are reference datums and do not include mold flash or protrusions, but do include mold mismatch and are measured at the parting line, mold flash or protrusions shall not exceed 0.20mm per side.
- Dimension b does not include dambar protrusion/intrusion. Allowable dambar protrusion shall be 0.13mm total in excess of b dimension at maximum material condition. Dambar intrusion shall not reduce dimension b by more than 0.07mm at least material condition.
- These dimensions apply to the flat section of the lead between 0.10 and 0.25mm from lead tips.

DIM	MILLIMETERS			INCHES			Note
	MIN	NOM	MAX	MIN	NOM	MAX	
A	-	-	2.13	-	-	0.084	
A1	0.05	0.15	0.25	0.002	0.006	0.010	
A2	1.62	1.75	1.88	0.064	0.070	0.074	
b	0.22	0.30	0.38	0.009	0.012	0.015	2, 3
D	see other table			see other table			1
E	7.40	7.80	8.20	0.291	0.307	0.323	
E1	5.00	5.30	5.60	0.197	0.209	0.220	1
e	0.61	0.65	0.69	0.024	0.026	0.027	
L	0.63	0.90	1.03	0.025	0.035	0.040	
N	see other table			see other table			
∞	0°	4°	8°	0°	4°	8°	

N	D			INCHES			Note
	MIN	NOM	MAX	MIN	NOM	MAX	
20	6.90	7.20	7.50	0.272	0.283	0.295	1
28	9.90	10.20	10.50	0.390	0.402	0.413	1

SMART
Analog™

This datasheet has been downloaded from:

www.DatasheetCatalog.com

Datasheets for electronic components.



LittleDiode supplies new, hard to find or obsolete electronic components and semiconductors all over the world.

With over two million different components listed you are sure to find the part you need.

Feel free to visit us today at our online store:

LittleDiode.com

Looking forward to providing you with the best possible service.