

24-Bit, 96 kHz Surround Sound Codec

Features

- Two 24-bit A/D Converters
 - 102 dB dynamic range
 - 90 dB THD+N
- Six 24-bit D/A Converters
 - 103 dB dynamic range and SNR
 - 90 dB THD+N
- Sample rates up to 100 kHz
- Pop-free Digital Output Volume Controls
 - 90.5 dB range, 0.5 dB resolution (182 levels)
 - Variable smooth ramp rate, 0.125 dB steps
- Mute Control pin for off-chip muting circuits
- On-chip Anti-alias and Output Filters
- De-emphasis filters for 32, 44.1 and 48 kHz

Description

The CS4228 codec provides two analog-to-digital and six digital-to-analog delta-sigma converters, along with volume controls, in a compact +5/+3.3 V, 28-pin SSOP device. Combined with an IEC958 (SPDIF) receiver (like the CS8414) and surround sound decoder (such as one of the CS492x or CS493xx families), it is ideal for use in DVD player, A/V receiver and car audio systems supporting multiple standards such as Dolby Digital AC-3, AAC, DTS, Dolby ProLogic, THX, and MPEG.

A flexible serial audio interface allows operation in Left Justified, Right Justified, I²S, or One Line Data modes.

ORDERING INFORMATION

CS4228-KS	-10° to +70° C	28-pin SSOP
CDB4228		Evaluation Board

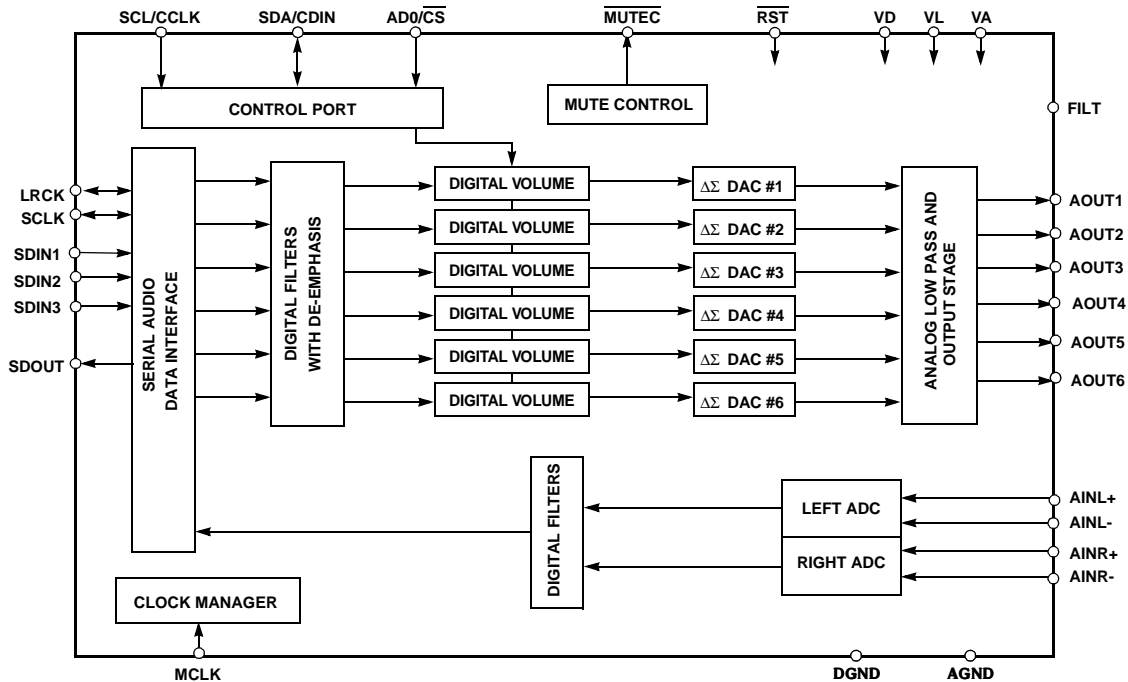

TABLE OF CONTENTS

CHARACTERISTICS AND SPECIFICATIONS	4
ANALOG CHARACTERISTICS.....	4
DIGITAL CHARACTERISTICS.....	6
SWITCHING CHARACTERISTICS	6
SWITCHING CHARACTERISTICS - CONTROL PORT	8
ABSOLUTE MAXIMUM RATINGS	10
RECOMMENDED OPERATING CONDITIONS	10
TYPICAL CONNECTION DIAGRAM	11
FUNCTIONAL DESCRIPTION	12
Overview	12
Analog Inputs	12
Line Level Inputs	12
High Pass Filter	12
Analog Outputs	12
Line Level Outputs	12
Digital Volume Control	13
Mute Control	13
Clock Generation	14
Clock Source	14
Synchronization	14
Digital Interfaces	14
Serial Audio Interface Signals	14
Serial Audio Interface Formats	14
Control Port Signals	14
SPI Mode	16
I ² C Mode	16
Control Port Bit Definitions	17
Power-up/Reset/Power Down Mode	17
Power Supply, Layout, and Grounding	18
REGISTER DESCRIPTION	19
PIN DESCRIPTION.....	24
PARAMETER DEFINITIONS	28
PACKAGE DIMENSIONS	29

Contacting Cirrus Logic Support

For a complete listing of Direct Sales, Distributor, and Sales Representative contacts, visit the Cirrus Logic web site at:
<http://www.cirrus.com/corporate/contacts/>

Dolby, Pro Logic, and AC-3 are trademarks of Dolby Laboratories Licensing Corporation.

Preliminary product information describes products which are in production, but for which full characterization data is not yet available. Advance product information describes products which are in development and subject to development changes. Cirrus Logic, Inc. has made best efforts to ensure that the information contained in this document is accurate and reliable. However, the information is subject to change without notice and is provided "AS IS" without warranty of any kind (express or implied). No responsibility is assumed by Cirrus Logic, Inc. for the use of this information, nor for infringements of patents or other rights of third parties. This document is the property of Cirrus Logic, Inc. and implies no license under patents, copyrights, trademarks, or trade secrets. No part of this publication may be copied, reproduced, stored in a retrieval system, or transmitted, in any form or by any means (electronic, mechanical, photographic, or otherwise) without the prior written consent of Cirrus Logic, Inc. Items from any Cirrus Logic website or disk may be printed for use by the user. However, no part of the printout or electronic files may be copied, reproduced, stored in a retrieval system, or transmitted, in any form or by any means (electronic, mechanical, photographic, or otherwise) without the prior written consent of Cirrus Logic, Inc. Furthermore, no part of this publication may be used as a basis for manufacture or sale of any items without the prior written consent of Cirrus Logic, Inc. The names of products of Cirrus Logic, Inc. or other vendors and suppliers appearing in this document may be trademarks or service marks of their respective owners which may be registered in some jurisdictions. A list of Cirrus Logic, Inc. trademarks and service marks can be found at <http://www.cirrus.com>.

LIST OF FIGURES

Figure 1. Serial Audio Port Master Mode Timing	7
Figure 2. Serial Audio Port Slave Mode Timing	7
Figure 3. SPI Control Port Timing	8
Figure 4. I ² C Control Port Timing	9
Figure 5. Recommended Connection Diagram	11
Figure 6. Optional Line Input Buffer	12
Figure 7. Passive Output Filter with Mute	13
Figure 8. Butterworth Output Filter with Mute	13
Figure 9. Right Justified Serial Audio Formats	15
Figure 10. I ² S Serial Audio Formats	15
Figure 11. Left Justified Serial Audio Formats	15
Figure 12. One Line Data Serial Audio Format	16
Figure 13. Control Port Timing, SPI mode	17
Figure 14. Control Port Timing, I ² C Mode	17

CHARACTERISTICS AND SPECIFICATIONS

ANALOG CHARACTERISTICS (Unless otherwise specified $T_A = 25^\circ\text{C}$; $V_A = +5\text{V}$, $V_D = V_L = +3.3\text{V}$; Full Scale Input Sine wave, 1kHz; $F_s = 44.1\text{ kHz BRM}$, 96 kHz HRM; Measurement Bandwidth is 20 Hz to 20 kHz; Local components as shown in "Recommended Connection Diagram"; SPI control mode, Left Justified serial format, MCLK = 256 F_s BRM, 128 F_s HRM, SCLK = 64 F_s)

Parameter	Symbol	Base Rate Mode			High Rate Mode			Units	
		Min	Typ	Max	Min	Typ	Max		
Analog Input Characteristics - Minimum gain setting (0 dB) Differential Input; unless otherwise specified.									
ADC Resolution	Stereo Audio channels	16	-	24	16	-	24	Bits	
Total Harmonic Distortion	THD	-	0.003	-	-	0.003	-	%	
Dynamic Range	(A weighted)	TBD	102	-	TBD	102	-	dB	
	(unweighted)	-	99	-	TBD	99	-	dB	
Total Harmonic Distortion + Noise	-1dB (Note 1)	THD+N	-	-90	TBD	-	-90	TBD	dB
Interchannel Isolation		-	90	-	-	90	-	dB	
Interchannel Gain Mismatch		-	0.1	-	-	0.1	-	dB	
Offset Error (with high pass filter)		-	-	0	-	-	0	LSB	
Full Scale Input Voltage (Differential):			5.66			5.66		Vp-p	
Gain Drift		-	100	-	-	100	-	ppm/ $^\circ\text{C}$	
Input Resistance		10	-	-	10	-	-	k Ω	
Input Capacitance		-	-	15	-	-	15	pF	
A/D Decimation Filter Characteristics									
Passband	(Note 2)	0.02	-	20.0	0.02	-	40	kHz	
Passband Ripple		-	-	0.01	-	-	0.05	dB	
Stopband	(Note 2)	27.56	-	5617	66.53	-	5578	kHz	
Stopband Attenuation	(Note 3)	80	-	-	45	-	-	dB	
Group Delay	(Note 4)	t_{gd}	-	15/ F_s	-	-	15/ F_s	s	
Group Delay Variation vs. Frequency		Δt_{gd}	-	-	0	-	-	0	μs
High Pass Filter Characteristics									
Frequency Response:	-3 dB (Note 2)	-	3.4	-	-	3.4	-	Hz	
	-0.13 dB	-	20	-	-	20	-	Hz	
Phase Deviation	@ 20 Hz (Note 2)	-	10	-	-	10	-	Degree	
Passband Ripple		-	-	0	-	-	0	dB	

- Notes:
1. Referenced to typical full-scale differential input voltage (2 Vrms).
 2. Filter characteristics scale with output sample rate.
 3. The analog modulator samples the input at 5.6448 MHz for an output sample rate of 44.1 kHz. There is no rejection of input signals which are multiples of the sampling frequency ($n \times 5.6448\text{ MHz} \pm 20.0\text{ kHz}$ where $n = 0,1,2,3\dots$).
 4. Group delay for $F_s = 44.1\text{ kHz}$, $t_{gd} = 15/44.1\text{ kHz} = 340\ \mu\text{s}$. $F_s =$ sample rate.

Specifications are subject to change without notice

ANALOG CHARACTERISTICS (Continued)

Parameter	Symbol	Base Rate Mode			High Rate Mode			Units
		Min	Typ	Max	Min	Typ	Max	
Analog Output Characteristics - Minimum Attenuation, 10 kΩ, 100 pF load; unless otherwise specified.								
DAC Resolution		16	-	24	16	-	24	Bits
Signal-to-Noise/Idle Channel Noise (DAC muted, A weighted)		TBD	103	-	TBD	103	-	dB
Dynamic Range (DAC not muted, A weighted)		TBD	103	-	-	103	-	dB
	(DAC not muted, unweighted)	-	100	-	-	100	-	dB
Total Harmonic Distortion	THD	-	0.003	-	-	0.003	-	%
Total Harmonic Distortion + Noise	THD+N	-	-90	TBD	-	-90	-	dB
Interchannel Isolation		-	90	-	-	90	-	dB
Interchannel Gain Mismatch		-	0.1	-	-	0.1	-	dB
Attenuation Step Size (All Outputs)		TBD	0.5	TBD	TBD	0.5	TBD	dB
Programmable Output Attenuation Span		TBD	-90.5	-	TBD	-90.5	-	dB
Offset Voltage		-	10	-	-	10	-	mV
Full Scale Output Voltage		TBD	1.3	TBD	-	1.3	-	V _{rms}
Gain Drift		-	100	-	-	100	-	ppm/°C
Analog Output Load	Minimum Load Resistance:	-	10	-	-	10	-	kΩ
	Maximum Load Capacitance:	-	100	-	-	100	-	pF
Combined Digital and Analog Filter Characteristics								
Frequency Response	10 Hz to 20 kHz		±0.1			±0.1		dB
Deviation from Linear Phase		-	±0.5	-	-	±0.5	-	Degrees
Passband: to 0.01 dB corner	(Notes 5, 6)	0	-	20.0	0	-	40	kHz
Passband Ripple	(Note 6)	-	-	±0.01	-	-	±0.01	dB
Stopband	(Notes 5, 6)	24.1	-	-	56	-	-	kHz
Stopband Attenuation	(Notes 4, 7)	70	-	-	65	-	-	dB
Group Delay (Fs = Input Word Rate)	tgd	-	16/Fs	-	-	16/Fs	-	s
Analog Loopback Performance								
Signal-to-noise Ratio (CCIR-2K weighted, -20 dB FS input)	CCIR-2K	-	TBD	-	-	TBD	-	dB

Notes: 5. The passband and stopband edges scale with frequency. For input word rates, Fs, other than 44.1 kHz, the 0.01 dB passband edge is 0.4535×Fs and the stopband edge is 0.5465×Fs.

6. Digital filter characteristics.

7. Measurement bandwidth is 10 Hz to 3 Fs.

Specifications are subject to change without notice

ANALOG CHARACTERISTICS (Continued)

Power Supply	Symbol	Min	Typ	Max	Min	Typ	Max	Units
Power Supply Current VA = 5V, VD = VL = 3.3V	Operating							
	VA	-	25	TBD	-	25	TBD	mA
	VL	-	2	TBD	-	2	TBD	mA
	VD	-	42	TBD	-	48	TBD	mA
	Power Down							
	VA	-	TBD	TBD	-	TBD	TBD	mA
	VL	-	2	TBD	-	2	TBD	mA
	VD	-	0.1	TBD	-	0.1	TBD	mA
Power Supply Rejection (1 kHz, 10 mV _{rms})		-	50	-		50		dB

DIGITAL CHARACTERISTICS Unless otherwise specified (T_A = 25 °C; VD = VL = +3.3V; VA = +5V)

Parameter	Symbol	Min	Typ	Max	Units
High-level Input Voltage	V _{IH}	0.7xVL	-	-	V
Low-level Input Voltage	V _{IL}		-	0.3xVL	V
High-level Output Voltage at I _O = -2.0 mA	V _{OH}	VL - 1.0	-	-	V
Low-level Output Voltage at I _O = 2.0 mA	V _{OL}	-	-	0.4	V
Input Leakage Current (Digital Inputs)		-	-	10	μA
Output Leakage Current (High-Impedance Digital Outputs)		-	-	10	μA

SWITCHING CHARACTERISTICS (T_A = 25°C; VD = VL = +3.3V, VA = +5V, outputs loaded with 30 pF)

Parameter	Symbol	Min	Typ	Max	Units	
Audio ADC's & DAC's Sample Rate	BRM	30	-	50	kHz	
	HRM	60	-	100	kHz	
MCLK Frequency		3.84	-	25.6	MHz	
MCLK Duty Cycle	BRM	MCLK = 128, 384 Fs	TBD	50	TBD	%
		MCLK = 256, 512 Fs	40		60	%
	HRM	MCLK = 64, 192 Fs	TBD	50	TBD	%
		MCLK = 128, 256 Fs	40	-	60	%
MCLK Jitter Tolerance		-	500	-	ps	

SWITCHING CHARACTERISTICS (Continued)

Parameter	Symbol		Typ	Max	Units
RST Low Time (Note 8)		1	-	-	ms
SCLK Falling Edge to SDOUT Output Valid (DSCK=0)	t_{dpd}		-	TBD	ns
LRCK Edge to MSB Valid	t_{lrpd}		-	TBD	ns
SDIN Setup Time Before SCLK Rising Edge	t_{ds}		-	TBD	ns
SDIN Hold Time After SCLK Rising Edge	t_{dh}		-	TBD	ns
Master Mode					
SCLK Falling to LRCK Edge	t_{mslr}		± 10	-	ns
SCLK Duty Cycle			50	-	%
Slave Mode					
SCLK Period	t_{sckw}		-	-	ns
SCLK High Time	t_{sckh}	TBD	-	-	ns
SCLK Low Time	t_{sckl}	TBD	-	-	ns
SCLK rising to LRCK Edge (DSCK=0)	t_{lrckd}	TBD	-	-	ns
LRCK Edge to SCLK Rising (DSCK=0)	t_{lrcks}	TBD	-	-	ns

Notes: 8. After powering up the CS4228, $\overline{\text{RST}}$ should be held low until the power supplies and clocks are settled.

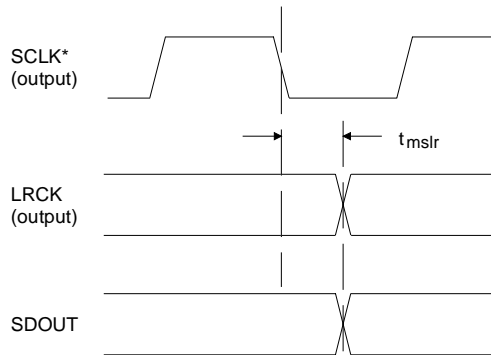
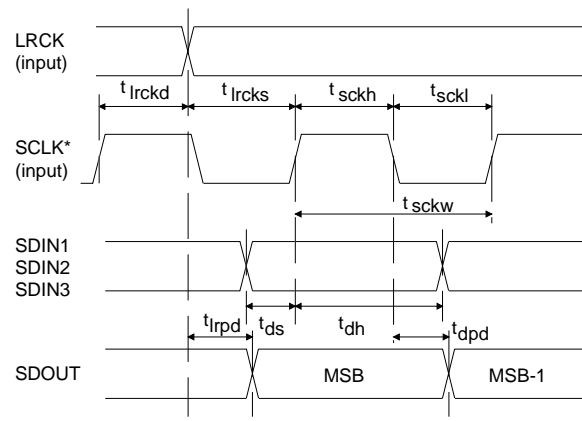

Figure 1. Serial Audio Port Master Mode Timing



*SCLK shown for DSCK = 0.
SCLK inverted for DSCK = 1.

Figure 2. Serial Audio Port Slave Mode Timing

SWITCHING CHARACTERISTICS - CONTROL PORT (TA = 25°C, VD = VL = +3.3V, VA = +5V; Inputs: logic 0 = DGND, logic 1 = VL+, CL = 30 pF)

Parameter	Symbol	Min	Max	Units
SPI Mode (SDOUT > 47kΩ to GND)				
CCLK Clock Frequency	f _{sck}	-	6	MHz
CS High Time Between Transmissions	t _{csh}	1.0		μs
CS Falling to CCLK Edge	t _{css}	20		ns
CCLK Low Time	t _{scl}	66		ns
CCLK High Time	t _{sch}	66		ns
CDIN to CCLK Rising Setup Time	t _{dsu}	40		ns
CCLK Rising to DATA Hold Time (Note 9)	t _{dh}	15		ns
Rise Time of CCLK and CDIN (Note 10)	t _{r2}		100	ns
Fall Time of CCLK and CDIN (Note 10)	t _{f2}		100	ns

Notes: 9. Data must be held for sufficient time to bridge the transition time of CCLK.

10. For F_{SCK} < 1 MHz

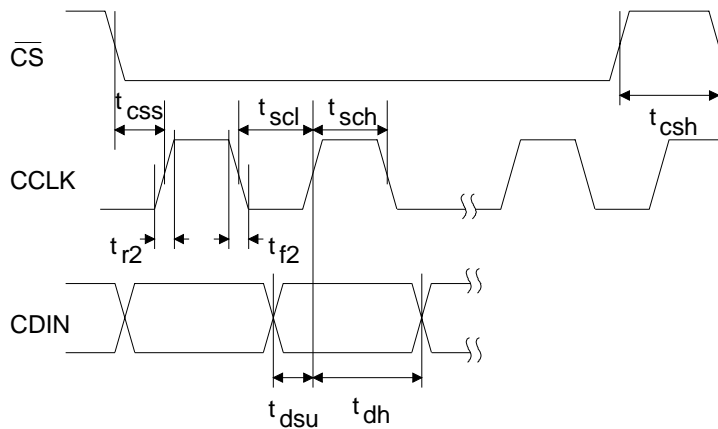
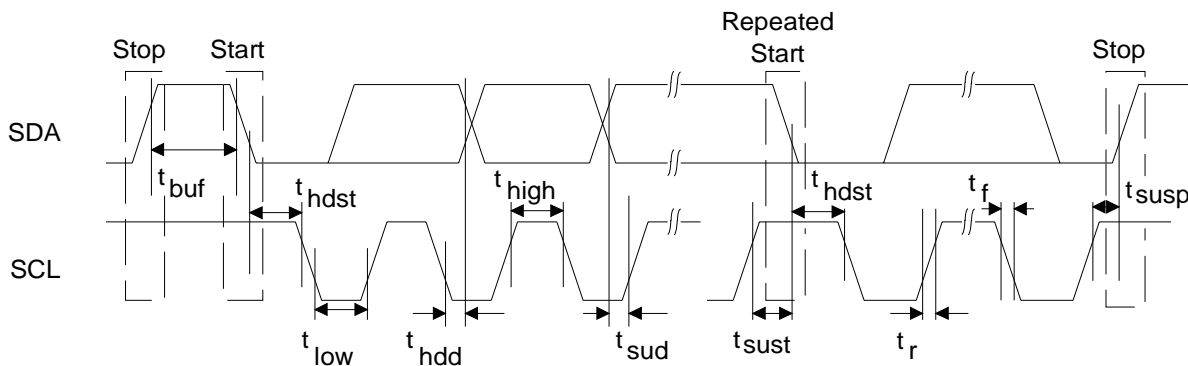

Figure 3. SPI Control Port Timing

SWITCHING CHARACTERISTICS - CONTROL PORT ($T_A = 25^\circ\text{C}$; $V_D = V_L = +3.3\text{V}$, $V_A = +5\text{V}$; Inputs: logic 0 = DGND, logic 1 = VL, $C_L = 30\text{ pF}$)

Parameter	Symbol	Min	Max	Units
I²C[®] Mode (SDOUT < 47kΩ to ground) (Note 11)				
SCL Clock Frequency	f_{scl}	-	100	kHz
Bus Free Time Between Transmissions	t_{buf}	4.7		μs
Start Condition Hold Time (prior to first clock pulse)	t_{hdst}	4.0		μs
Clock Low Time	t_{low}	4.7		μs
Clock High Time	t_{high}	4.0		μs
Setup Time for Repeated Start Condition	t_{sust}	4.7		μs
SDA Hold Time from SCL Falling (Note 12)	t_{hdd}	0		μs
SDA Setup Time to SCL Rising	t_{sud}	250		ns
Rise Time of Both SDA and SCL Lines	t_r		1	μs
Fall Time of Both SDA and SCL Lines	t_f		300	ns
Setup Time for Stop Condition	t_{susp}	4.7		μs

- Notes: 11. Use of the I²C bus interface requires a license from Philips. I²C is a registered trademark of Philips Semiconductors.
12. Data must be held for sufficient time to bridge the 300 ns transition time of SCL.

Figure 4. I²C Control Port Timing

ABSOLUTE MAXIMUM RATINGS (AGND, DGND = 0 V, all voltages with respect to 0 V.)

Parameter	Symbol	Min	Typ	Max	Units	
Power Supplies	Digital	VD	-0.3	-	6.0	V
	Analog	VA	-0.3	-	6.0	V
	Interface	VL	-0.3	-	6.0	V
Input Current	(Note 13)	-	-	±10	mA	
Analog Input Voltage	(Note 14)	-0.7	-	VA + 0.7	V	
Digital Input Voltage	(Note 14)	-0.7	-	VL + 0.7	V	
Ambient Temperature	(Power Applied)	-55	-	+125	°C	
Storage Temperature		-65	-	+150	°C	

Notes: 13. Any pin except supplies. Transient currents of up to ±100 mA on the analog input pins will not cause SCR latch-up.

14. The maximum over or under voltage is limited by the input current.

Warning: Operation at or beyond these limits may result in permanent damage to the device. Normal operation is not guaranteed at these extremes.

RECOMMENDED OPERATING CONDITIONS (AGND, DGND = 0 V, all voltages with respect to 0 V.)

Parameter	Symbol	Min	Typ	Max	Units	
Power Supplies	Digital	VD	TBD	3.3	TBD	V
	Analog	VA	4.75	5.0	5.25	V
	Interface	VL	2.7	5.0	5.25	V
Operating Ambient Temperature	T _A	-10	25	70	°C	

FUNCTIONAL DESCRIPTION

Overview

The CS4228 is a 24-bit audio codec comprised of 2 analog-to-digital converters (ADC) and 6 digital-to-analog converters (DAC), all implemented using single-bit delta-sigma techniques. Other functions integrated with the codec include independent digital volume controls for each DAC, digital DAC de-emphasis filters, ADC high-pass filters, an on-chip voltage reference, and a flexible serial audio interface. All functions are configured through a serial control port operable in SPI and I²C compatible modes. Figure 5 shows the recommended connections for the CS4228.

Analog Inputs

Line Level Inputs

AINR+, AINR-, AINL+, and AINL- are the line level analog inputs (See Figure 5). These pins are internally biased to a DC operating voltage of approximately 2.3 VDC. AC coupling the inputs preserves this bias and minimizes signal distortion. Figure 5 shows operation with a single-ended input source. This source may be supplied to either the positive or negative input as long as the unused input is connected to ground through capacitors as shown. When operated with single-ended inputs, distortion will increase at input levels higher than -1 dBFS. Figure 6 shows an example of a differential input circuit.

Muting of the stereo ADC is possible through the ADC Control Byte.

The ADC output data is in 2's complement binary format. For inputs above positive full scale or below negative full scale, the ADC will output 7FFFFFFH or 800000H, respectively.

High Pass Filter

Digital high pass filters in the signal path after the ADCs remove any DC offsets present on the analog

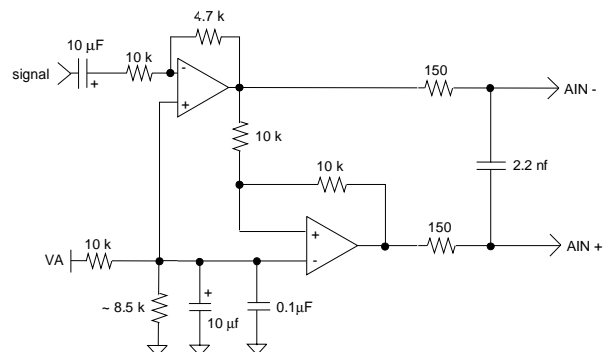

Figure 6. Optional Line Input Buffer

inputs. This helps to prevent audible "clicks" when switching the audio in devices downstream from the ADCs. The high pass filter response, given in "High Pass Filter Characteristics" on page 4, scales linearly with sample rate. Thus, for High Rate Mode, the -3 dB frequency at a 96 kHz sample rate will be equal to 96/44.1 times that at a sample rate of 44.1 kHz.

The high pass filters can be disabled by setting the HPF bit in the ADC Control register. When asserted, any DC present at the analog inputs will be represented in the ADC outputs. The high pass filter may also be "frozen" using the HPFZ bit in the ADC Control register. In this condition, it will remember the DC offset present at the ADC inputs at the moment the HPFZ bit was asserted, and will continue to remove this DC level from the ADC outputs. This is useful in cases where it is desirable to eliminate a fixed DC offset while still maintaining full frequency response down to DC.

Analog Outputs

Line Level Outputs

The CS4228 contains on-chip buffer amplifiers capable of producing line level outputs. These amplifiers are biased to a quiescent DC level of approximately 2.3 V. This bias, as well as variations in offset voltage, are removed using off-chip AC load coupling.

High frequency noise beyond the audio passband, resulting from the delta-sigma conversion process produces high frequency noise beyond the audio passband, most of which is removed by the on-chip analog filters. The remaining out-of-band noise can be attenuated using an off-chip low pass filter. For most applications, a simple passive filter as show in Figure 7 can be used. Note that this circuit also serves to block the DC present at the outputs. Figure 8 gives an example of a filter which can be used in applications where greater out of band attenuation is desired. The 2-pole Butterworth filter has a -3 dB frequency of 50 kHz, a passband attenuation of 0.1 dB at 20 kHz providing optimal out-of-band filtering for sample rates from 44.1 kHz to 96 kHz. The filter has and a gain of 1.56 providing a 2 V_{rms} output signal.

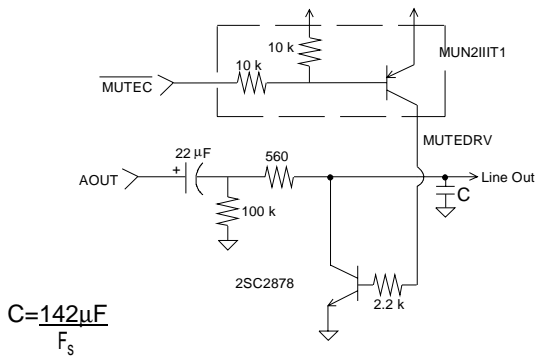

Figure 7. Passive Output Filter with Mute

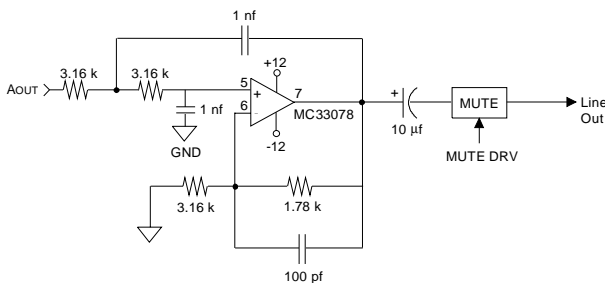

Figure 8. Butterworth Output Filter with Mute

Digital Volume Control

Each DAC’s output level is controlled via the Digital Volume Control register operating over the range of 0 to 90.5 dB attenuation with 0.5 dB resolution. Volume control changes do not occur instantaneously. Instead they ramp in increments of 0.125 dB at a variable rate controlled by the RMP1:0 bits in the Digital Volume Control register.

Each output can be independently muted via mute control bits MUT6-1 in the DAC Mute1 Control register. When asserted, MUT attenuates the corresponding DAC to its maximum value (90.5 dB). When MUT is deasserted, the corresponding DAC returns to the attenuation level set in the Digital Volume Control register. The attenuation is ramped up and down at the rate specified by the RMP1:0 bits.

To achieve complete digital attenuation of an incoming signal, Hard Mute controls are provided. When asserted, Hard Mute will send zero data to a corresponding pair of DACs. Hard Mute is not ramped, so it should only be asserted after setting the two corresponding MUT bits to prevent high frequency noise from appearing on the DAC outputs. Hard Mute is controlled by the HMUTE56/34/12 bits in the DAC Mute2 Control register.

Mute Control

The Mute Control pin is typically connected to an external mute control circuit as shown in Figure 7 and Figure 8. Mute Control is asserted during power up, power down, and when serial port clock errors are present. The pin can also be controlled by the user via the control port, or automatically asserted when zero data is present on all six DAC inputs. To prevent large transients on the output, it is desirable to mute the DAC outputs before the Mute Control pin is asserted. Please see the MUTE \overline{C} pin in the Pin Descriptions section for more information.

Clock Generation

The master clock, MCLK, is supplied to the CS4228 from an external clock source. If MCLK stops for 10 μ s, the CS4228 will enter Power Down Mode in which the supply current is reduced as specified under “Power Supply” on page 6. In all modes it is required that the number of MCLK periods per SCLK and LRCK period be constant.

Clock Source

The CS4228 internal logic requires an external master clock, MCLK, that operates at multiples of the sample rate frequency, Fs. The MCLK/Fs ratio is determined by the CI1:0 bits in the CODEC Clock Mode register.

Synchronization

The serial port is internally synchronized with MCLK. If from one LRCK cycle to the next, the number of MCLK cycles per LRCK cycle changes by more than 32, the CS4228 will undergo an internal reset of its data paths in an attempt to resynchronize. Consequently, it is advisable to mute the DACs when changing from one clock source to another to avoid the output of undesirable audio signals as the device resynchronizes.

Digital Interfaces

Serial Audio Interface Signals

The serial audio data is presented in 2's complement binary form with the MSB first in all formats. The serial interface clock, SCLK, is used for both transmitting and receiving audio data. SCLK can be generated by the CS4228 (master mode) or it can be input from an external source (slave mode). Mode selection is made with the DMS1:0 bits in the Serial Port Mode register. The number of SCLK cycles in one sample period can be set using the DCK1:0 bits as detailed in the Serial Port Mode register.

The Left/Right clock (LRCK) is used to indicate left and right data frames and the start of a new sample period. It may be an output of the CS4228 (master mode), or it may be generated by an external source (slave mode). The frequency of LRCK is the same as the system sample rate, Fs.

SDIN1, SDIN2, and SDIN3 are the data input pins. SDOUT, the data output pin, carries data from the two 24-bit ADC's. The serial audio port may also be operated in One Line Data Mode in which all 6 channels of DAC data is input on SDIN1 and the stereo ADC data is output on SDOUT. Table 1 outlines the serial port input to DAC channel allocations.

<i>DAC Inputs</i>		
SDIN1	left channel	DAC #1
	right channel	DAC #2
	single line	All 6 DAC channels
SDIN2	left channel	DAC #3
	right channel	DAC #4
SDIN3	left channel	DAC #5
	right channel	DAC #6

Table 1. Serial Audio Port Input Channel Allocations

Serial Audio Interface Formats

The digital audio port supports 6 formats, shown in Figures 9, 10, 11 and 12. These formats are selected using the DDF2:0 bits in the Serial Port Mode register.

In One Line Data Mode, all 6 DAC channels are input on SDIN1. One Line Data Mode is only available in BRM. See Figure 12 for channel allocations.

Control Port Signals

Internal registers are accessed through the control port. The control port may be operated asynchronously with respect to audio sample rate. However, to avoid potential interference problems, the control port pins should remain static if no register access is required.

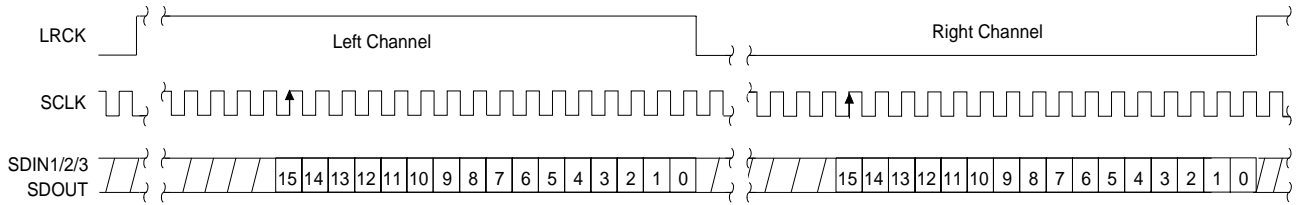

Right Justified Mode, Data Valid on Rising Edge of SCLK		
Bits/Sample	SCLK Rate(s)	Notes
16	32, 48, 64, 128 Fs	48 Fs Slave only
20	48, 64, 128 Fs	48 Fs Slave only
24	48, 64, 128 Fs	48 Fs Slave only

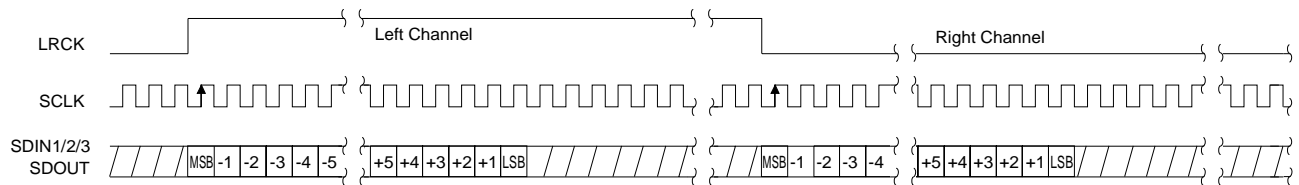
Figure 9. Right Justified Serial Audio Formats

Left Justified Mode, Data Valid on Rising Edge of SCLK		
Bits/Sample	SCLK Rate(s)	Notes
16	32, 48, 64, 128 Fs	48 Fs Slave only
18 to 24	48, 64, 128 Fs	48 Fs Slave only

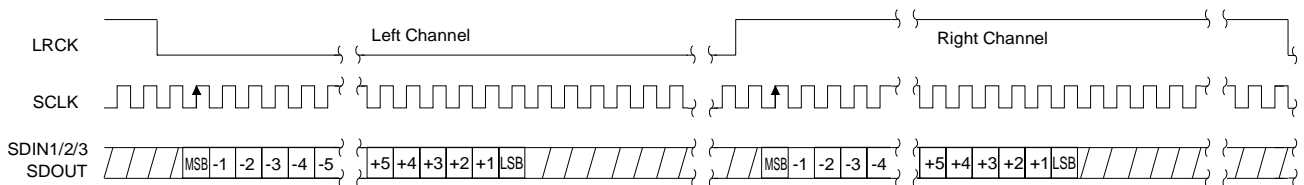
Figure 10. Left Justified Serial Audio Formats

I2S Mode, Data Valid on Rising Edge of SCLK		
Bits/Sample	SCLK Rate(s)	Notes
16	32, 48, 64, 128 Fs	48 Fs Slave only
18 to 24	48, 64, 128 Fs	48 Fs Slave only

Figure 11. I²S Serial Audio Formats

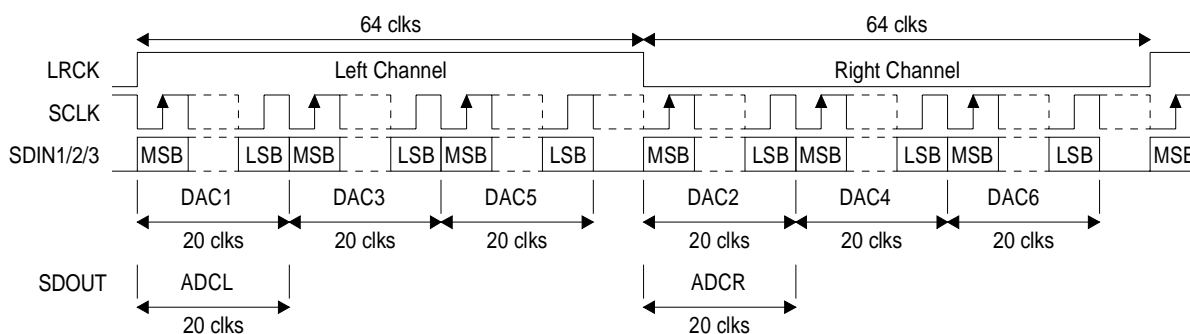

One Line Data Mode, Data Valid on Rising Edge of SCLK		
Bits/Sample	SCLK Rate(s)	Notes
20	128 Fs	6 inputs, 2 outputs, BRM only

Figure 12. One Line Data Serial Audio Format

The control port has 2 operating modes: SPI and I²C compatible. In both modes the CS4228 operates as a slave device. Mode selection is determined by the state of the SDOUT pin when RST transitions from low to high: high for SPI, low for I²C. SDOUT is internally pulled high to VL. A resistive load from SDOUT to DGND of less than 47 kΩ will enable I²C Mode after a reset.

SPI Mode

In SPI mode, \overline{CS} is the CS4228 chip select signal, CCLK is the control port bit clock input, and CDIN is the input data line. There is no data output line, therefore all registers are write-only in SPI mode. Data is clocked in on the rising edge of CCLK.

Figure 13 shows the operation of the control port in SPI mode. The first 7 bits on CDIN, after \overline{CS} goes low, form the chip address (0010000). The eighth bit is a read/write indicator (R/W), which should be low to write. The next 8 bits set the Memory Address Pointer (MAP) which is the address of the register that is to be written. The following bytes contain the data which will be placed into the registers designated by the MAP.

The CS4228 has a MAP auto increment capability, enabled by the INCR bit in the MAP register. If INCR is zero, then the MAP will stay constant for successive reads or writes. If INCR is 1, then MAP will increment after each byte is read or written, allowing block reads or writes of successive registers.

I²C Mode

In I²C mode, SDA is a bidirectional data line. Data is clocked into and out of the port by the SCL clock. The signal timing is shown in Figure 14. The AD0 pin forms the LSB of the chip address. The upper 6 bits of the 7 bit address field must be 001000. To communicate with a CS4228, the LSB of the chip address field, which is the first byte sent to the CS4228 after a Start condition, should match the setting of the AD0 pin. The eighth bit of the address bit is the R/W bit (high for a read, low for a write). When writing, the next byte is the Memory Address Pointer (MAP) which selects the register to be read or written. If the operation is a read, the contents of the register pointed to by the MAP will be output. Setting the auto increment bit in the

MAP allows successive reads or writes of consecutive registers. Each byte is separated by an acknowledge bit.

Control Port Bit Definitions

All registers are read/write, except the Chip Status register which is read-only. For more detailed information, see the bit definition tables starting on page 19.

Power-up/Reset/Power Down Mode

Upon power up, the user should hold $\overline{RST} = 0$ until the power supplies and clocks stabilize. In this state, the control registers are reset to their default settings, and the device remains in a low power

mode in which the control port is inactive. The part may be held in a low power reset state by clearing the \overline{DIGPDN} bit in the Chip Control register. In this state, the digital portions of the CODEC are in reset, but the control port is active and the desired register settings can be loaded. Normal operation is achieved by setting the \overline{DIGPDN} bit to 1, at which time the CODEC powers up and normal operation begins.

The CS4228 will enter a stand-by mode if the master clock source stops for approximately 10 μs or if the number of MCLK cycles per LRCK period varies by more than 32. Should this occur, the control registers retain their settings.

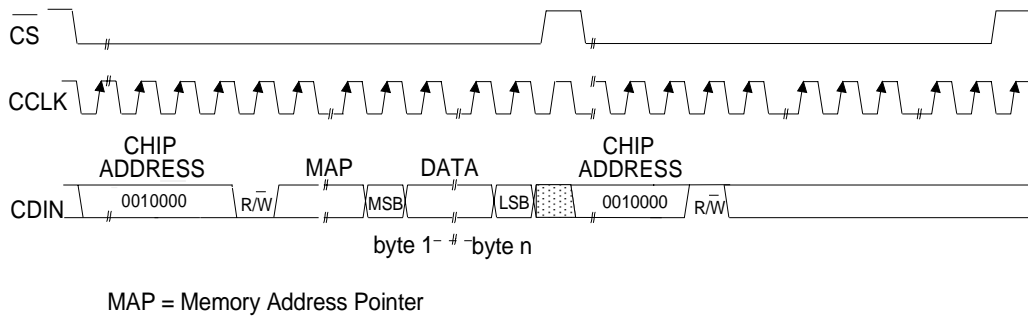

Figure 13. Control Port Timing, SPI mode

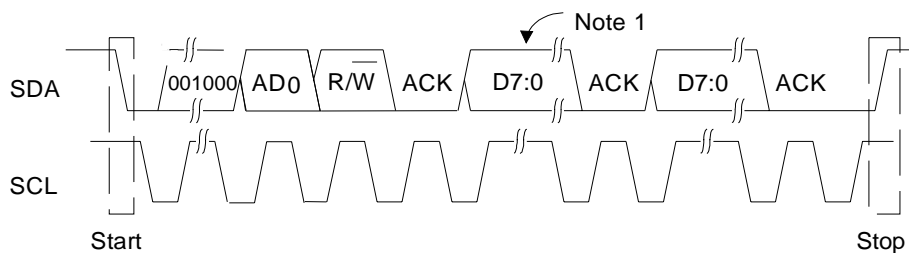

Figure 14. Control Port Timing, I²C Mode

The CS4228 will mute the analog outputs, assert the $\overline{\text{MUTE}}\text{C}$ pin and enter the Power Down Mode if the supply drops below approximately 4 volts.

Power Supply, Layout, and Grounding

The CS4228 requires careful attention to power supply and grounding details. VA is normally supplied from the system analog supply. VD is from a 3.3VDC supply, and VL should be from the supply used for the devices digitally interfacing with the CS4228. The power up sequence of these three supply pins is not important.

AGND and DGND pins should both be tied to a solid ground plane surrounding the CS4228. If the system analog and digital ground planes are separate, they should be connected at a point near where

the supply currents enter the board. A solid ground plane underneath the part is recommended.

Decoupling capacitors should be mounted in such a way as to minimize the circuit path length from the CS4228 supply pin, through the capacitor, to the applicable CS4228 AGND or DGND pin. The small value ceramic capacitors should be closest to the part. In some cases, ferrite beads in the VL, VD and VA supply lines, and low-value resistances ($\sim 50\ \Omega$) in series with the LRCK, SCLK, and SD-OUT lines can help reduce coupling of digital signals into the analog.

The capacitor on the FILT pin should be as close to the CS4228 as possible. See Crystal's layout Applications Note, and the CDB4228 evaluation board data sheet for recommended layout of the decoupling components.

REGISTER DESCRIPTION

All registers are read/write except for Chip Status, which is read only. See the following bit definition tables for bit assignment information. The default bit state after power-up sequence or reset is listed underneath the bit definition for that field. Default values are also marked with an asterick.

Memory Address Pointer (MAP) - not a register

7	6	5	4	3	2	1	0
INCR	RESERVED		MAP4	MAP3	MAP2	MAP1	MAP0
1	0	0	0	0	0	0	1

INCR memory address pointer auto increment control
 0 - MAP is not incremented automatically.
 *1 - internal MAP is automatically incremented after each read or write.

MAP4:0 Memory address pointer (MAP). Sets the register address that will be read or written by the control port.

CODEC Clock Mode

Address 0x01

7	6	5	4	3	2	1	0
HRM	RESERVED			CI1	CI0	RESERVED	
0	0	0	0	0	1	0	0

HRM Sets the sample rate mode for the ADCs and DACs
 *0 - Base Rate Mode (BRM) supports sample rates up to 50kHz
 1 - High Rate Mode (HRM) supports sample rates up to 100 kHz. Typically used for 96 kHz sample rate.

CI1:0 Specifies the ratio of MCLK to the sample rate of the ADCs and DACs (Fs)

CI1:0	BRM (Fs)	HRM (Fs)
0	128	64
*1	256	128
2	384	192
3	512	256

Chip Control

Address 0x02

7	6	5	4	3	2	1	0
DIGPDN	RESERVED		ADCPDN	DACPDN56	DACPDN34	DACPDN12	RESERVED
1	0	0	0	0	0	0	0

DIGPDN Power down the digital portions of the CODEC
 0 - Digital power down.
 *1 - Normal operation

ADCPDN Power down the analog section of the ADC
 *0 - Normal
 1 - ADC power down.

DACPDN12 Power down the analog section of DAC 1&2
 *0 - Normal
 1 - Power down DAC 1&2.

DACPDN34 Power down the analog section of DAC 3&4
 *0 - Normal
 1 - Power down DAC 3&4.

DACPDN56 Power down the analog section of DAC 5&6
 *0 - Normal
 1 - Power down DAC 5&6.

ADC Control

Address 0x03

7	6	5	4	3	2	1	0
MUTL	MUTR	HPF	HPFZ	RESERVED			
0	0	0	0	0	0	0	0

MUTL, MUTR ADC left and right channel mute control
 *0 - Normal
 1 - Selected ADC output muted

HPF ADC DC offset removal. See “High Pass Filter” on page 12 for more information
 *0 - Enabled
 1 - Disabled

HPFZ ADC DC offset averaging freeze. See “High Pass Filter” on page 12 for more information
 *0 - Normal. The DC offset average is dynamically calculated and subtracted from incoming ADC data.
 1 - Freeze. The DC offset average is frozen at the current value and subtracted from incoming ADC data. Allows passthru of DC information.

DAC Mute1 Control

Address 0x04

7	6	5	4	3	2	1	0
MUT6	MUT5	MUT4	MUT3	MUT2	MUT1	RMP1	RMP0
1	1	1	1	1	1	0	0

MUT6 - MUT1 Mute control for DAC6 - DAC1 respectively. When asserted, the corresponding DAC is digitally attenuated to its maximum value (90.5 dB). When deasserted, the corresponding DAC attenuation value returns to the value stored in the corresponding Digital Volume Control register. The attenuation value is ramped up and down at the rate specified by RMP1:0.

- 0 - Normal output level
- *1 - Selected DAC output fully attenuated.

RMP1:0 Attenuation ramp rate.

- *0 - 0.5dB change per 4 LRCKs
- 1 - 0.5dB change per 8 LRCKs
- 2 - 0.5dB change per 16 LRCKs
- 3 - 0.5dB change per 32 LRCKs

DAC Mute2 Control

Address 0x05

7	6	5	4	3	2	1	0
MUTE \overline{C}	MUTCZ	RESERVED		HMUTE56	HMUTE34	HMUTE12	RESERVED
0	0	0	0	0	0	0	0

MUTE \overline{C} Controls the $\overline{\text{MUTE}}\overline{C}$ pin

- *0 - Normal operation
- 1 - $\overline{\text{MUTE}}\overline{C}$ pin asserted low

MUTCZ Automatically asserts the $\overline{\text{MUTE}}\overline{C}$ pin on consecutive zeros. When enabled, 512 consecutive zeros on all six DAC inputs will cause the $\overline{\text{MUTE}}\overline{C}$ pin to be asserted low. A single non-zero value on any DAC input will cause the $\overline{\text{MUTE}}\overline{C}$ pin to deassert.

- *0 - Disabled
- 1 - Enabled

HMUTE56/34/12 Hard mute the corresponding DAC pair. When asserted, zero data is sent to the corresponding DAC pair causing an instantaneous mute. To prevent high frequency transients on the outputs, a DAC pair should be fully attenuated by asserting the corresponding MUT6-MUT1 bits in the DAC Mute Control register or by writing 0xFF to the corresponding Digital Volume Control registers before asserting HMUTE.

- *0 - Normal operation
- 1 - DAC pair is muted

DAC De-emphasis Control

Address 0x06

7	6	5	4	3	2	1	0
DEMS1	DEMS0	DEM6	DEM5	DEM4	DEM3	DEM2	DEM1
1	0	0	0	0	0	0	0

DEMS1:0 Selects the DAC de-emphasis response curve.

- 0 - Reserved
- 1 - De-emphasis for 48 kHz
- *2 - De-emphasis for 44.1 kHz
- 3 - De-emphasis for 32 kHz

DEM6 - DEM1 De-emphasis control for DAC6 - DAC1 respectively

- *0 - De-emphasis off
- 1 - De-emphasis on

Digital Volume Control

Addresses 0x07, 0x08, 0x09, 0x0A, 0x0B, 0x0C

7	6	5	4	3	2	1	0
VOLn							
0	0	0	0	0	0	0	0

VOL6 - VOL1 Address 0x0C - 0x07 sets the attenuation level for DAC 6 - DAC1 respectively. The attenuation level is ramped up and down at the rate specified by RMP1:0 in the DAC Volume Control Setup register.

0 - 181 represents 0 to 90.5 dB of attenuation in 0.5 dB steps.

Serial Port Mode

Address 0x0D

7	6	5	4	3	2	1	0
DCK1	DCK0	DMS1	DMS0	RESERVED	DDF2	DDF1	DFF0
1	0	0	0	0	1	0	0

DCK1:0 Sets the number of Serial Clocks (SCLK) per Fs period (LRCLK)

DCK1:0	BRM (Fs)	HRM (Fs)
0	32 (1)	16 (3)
1	48 (2)	24 (4)
2	*64	32 (1)
3	128	64

- Notes:
1. All formats will default to 16 bits
 2. External Slave mode only
 3. Only valid for left justified and I²S modes
 4. Only valid for left justified and I²S, External Slave mode only

DMS1:0 Sets the master/slave mode of the serial audio port

- *0 - Slave (External LRCLK, SCLK)
- 1 - Reserved
- 2 - Reserved
- 3 - Master (No 48 Fs SCLK in BRM, no 24 Fs SCLK in HRM)

DDF2:0 Serial Port Data Format

- 0 - Right Justified, 24-bit
- 1 - Right Justified, 20-bit
- 2 - Right Justified, 16-bit
- 3 - Left Justified, maximum 24-bit
- *4 - I²S compatible, maximum 24-bit
- 5 - One-line Data Mode, available in BRM only
- 6 - Reserved
- 7 - Reserved

Chip Status

Address 0x0E

7	6	5	4	3	2	1	0
CLKERR	ADCOVL	RESERVED					
X	X	0	0	0	0	0	0

CLKERR Clocking system status, read only

- 0 - No Error
- 1 - No MCLK is present, or a request for clock change is in progress

ADCOVL ADC overflow bit, read only

- 0 - No overflow
- 1 - ADC overflow has occurred

PIN DESCRIPTION

Serial Audio Data In 3	SDIN3	□ 1	28 □	AOUT6	Analog Output 6
Serial Audio Data In 2	SDIN2	□ 2	27 □	AOUT5	Analog Output 5
Serial Audio Data In 1	SDIN1	□ 3	26 □	AOUT4	Analog Output 4
Serial Audio Data Out	SDOUT	□ 4	25 □	AOUT3	Analog Output 3
Serial Clock	SCLK	□ 5	24 □	AOUT2	Analog Output 2
Left/Right Clock	LRCK	□ 6	23 □	AOUT1	Analog Output 1
Digital Ground	DGND	□ 7	22 □	AGND	Analog Ground
Digital Power	VD	□ 8	21 □	VA	Analog Power
Digital Interface Power	VL	□ 9	20 □	AINL+	Left Channel Analog Input+
Master Clock	MCLK	□ 10	19 □	AINL-	Left Channel Analog Input-
SCL/CCLK	SCL/CCLK	□ 11	18 □	FILT	Internal Voltage Filter
SDA/CDIN	SDA/CDIN	□ 12	17 □	AINR-	Right Channel Analog Input-
AD0/CS	AD0/CS	□ 13	16 □	AINR+	Right Channel Analog Input+
Reset	RST	□ 14	15 □	MUTEC	Mute Control

Serial Audio Data In - SDIN3, SDIN2, SDIN1

Pin 1, 2, 3, Input

Function:

Two's complement MSB-first serial audio data is input on this pin. The data is clocked into SDIN1, SDIN2, SDIN3 via the serial clock and the channel is determined by the Left/Right clock. The required relationship between the Left/Right clock, serial clock and serial data is defined by the Serial Mode Register. The options are detailed in Figures 9, 10, 11 and 12.

Serial Audio Data Out - SDOUT

Pin 4, Output

Function:

Two's complement MSB-first serial data is output on this pin. The data is clocked out of SDOUT via the serial clock and the channel is determined by the Left/Right clock. The required relationship between the Left/Right clock, serial clock and serial data is defined by the Serial Mode Register. The options are detailed in Figures 9, 10, 11 and 12.

The state of the SDOUT pin during reset is used to set the Control Port Mode (I2C or SPI). When $\overline{\text{RST}}$ is low, SDOUT is configured as an input, and the rising edge of $\overline{\text{RST}}$ latches the state of the pin. A weak internal pull up is present such that a resistive load less than 47 kΩ will pull the pin low, and the control port mode is I2C. When the resistive load on SDOUT is greater than 47 kΩ during reset, the control port mode is SPI.

Serial Clock — SCLK

Pin 5, Bidirectional

Function:

Clocks serial data into the SDIN1, SDIN2, and SDIN3 pins, and out of the SDOUT pin. The pin is an output in master mode, and an input in slave mode.

In master mode, SCLK is configured as an output. MCLK is divided internally to generate SCLK at the desired multiple of the sample rate.

In slave mode, SCLK is configured as an input. The serial clock can be provided externally, or the pin can be grounded and the serial clock derived internally from MCLK.

The required relationship between the Left/Right clock, serial clock and serial audio data is defined by the Serial Port Mode register. The options are detailed in Figures 9, 10, 11 and 12.

Left/Right Clock — LRCK

Pin 6, Bidirectional

Function:

The Left/Right clock determines which channel is currently being input or output on the serial audio data output, SDOUT. The frequency of the Left/Right clock must be at the output sample rate, F_s . In Master mode, LRCK is an output, in Slave Mode, LRCK is an input whose frequency must be equal to F_s and synchronous to the Master clock.

Audio samples in Left/Right pairs represent simultaneously sampled analog inputs whereas Right/Left pairs will exhibit a one sample period difference. The required relationship between the Left/Right clock, serial clock and serial data is defined by the Serial Port Mode register. The options are detailed in Figures 9, 10, 11 and 12.

Digital Ground - DGND

Pin 7, Inputs

Function:

Digital ground reference.

Digital Power - VD

Pin 8, Input

Function:

Digital power supply. Typically 3.3 VDC.

Digital Interface Power - VL

Pin 9, Input

Function:

Digital interface power supply. Typically 3.3 or 5.0 VDC. All digital output voltages and input thresholds scale with VL.

Master Clock - MCLK

Pin 10, Input

Function:

The master clock frequency must be either 128x, 256x, 384x or 512x the input sample rate in Base Rate Mode (BRM) and either 64x, 128x, 192x, or 256x the input sample rate in High Rate Mode (HRM). Table 2 illustrates several standard audio sample rates and the required master clock frequencies. The MCLK/Fs ration is set by the CI1:0 bits in the CODEC Clock Mode register

Sample Rate (kHz)	MCLK (MHz)							
	HRM				BRM			
	64x	128x	192x	256x	128x	256x	384x	512x
32	-	-	-	-	4.0960	8.1920	12.2880	16.3840
44.1	-	-	-	-	5.6448	11.2896	16.9344	22.5792
48	-	-	-	-	6.1440	12.2880	18.4320	24.5760
64	4.0960	8.1920	12.2880	16.3840	-	-	-	-
88.2	5.6448	11.2896	16.9344	22.5792	-	-	-	-
96	6.1440	12.2880	18.4320	24.5760	-	-	-	-

Table 2. Common Master Clock Frequencies

Serial Control Interface Clock - SCL/CCLK

Pin 11, Input

Function:

Clocks serial control data into or out of SDA/CDIN.

Serial Control Data I/O - SDA/CDIN

Pin 12, Bidirectional/Input

Function:

In I²C mode, SDA is a bidirectional control port data line. A pull up resistor must be provided for proper open drain output operation. In SPI mode, CDIN is the control port data input line. The state of the SDO_{UT} pin during reset is used to set the control port mode.

Address Bit 0 / Chip Select - AD0/ $\overline{\text{CS}}$

Pin 13, Input

Function:

In I²C mode, AD0 is the LSB of the chip address. In SPI mode, $\overline{\text{CS}}$ is used as a enable for the control port interface.

Reset - $\overline{\text{RST}}$

Pin 14, Input

Function:

When low, the device enters a low power mode and all internal registers are reset to the default settings, including the control port. The control port can not be accessed when reset is low.

When high, the control port and the CODEC become operational.

Mute Control - $\overline{\text{MUTEC}}$ *Pin 15, Output**Function:*

The Mute Control pin goes low during the following conditions: power-up initialization, power-down, reset, no master clock present, or if the master clock to left/right clock frequency ratio is incorrect. The Mute Control pin can also be user controlled by the MUTEC bit in the DAC Mute2 Control register. Mute Control can be automatically asserted when 512 consecutive zeros are detected on all six DAC inputs, and automatically deasserted when a single non-zero value is sent to any of the six DACs. The mute on zero function is controlled by the MUTCZ bit in the DAC Mute2 Control register. The $\overline{\text{MUTEC}}$ pin is intended to be used as a control for an external mute circuit to achieve a very low noise floor during periods when no audio is present on the DAC outputs, and to prevent the clicks and pops that can occur in any single supply system. Use of the Mute Control pin is not mandatory but recommended.

Differential Analog Inputs — AINR+, AINR- and AINL+, AINL-*Pins 16, 17 and 19, 20, Inputs**Function:*

The analog signal inputs are presented differentially to the modulators via the AINR+/- and AINL+/- pins. The + and - input signals are 180° out of phase resulting in a nominal differential input voltage of twice the input pin voltage. These pins are biased to the internal reference voltage of approximately 2.3 V. A passive anti-aliasing filter is required for best performance, as shown in Figure 5. The inputs can be driven at -1dB FS single-ended if the unused input is connected to ground through a large value capacitor. A single ended to differential converter circuit can also be used for slightly better performance.

Internal Voltage Filter - FILT*Pin 18, Output**Function:*

Filter for internal circuits. An external capacitor is required from FILT to analog ground, as shown in Figure 5. FILT is not intended to supply external current. FILT+ has a typical source impedance of 250 k Ω and any current drawn from this pin will alter device performance. Care should be taken during board layout to keep dynamic signal traces away from this pin.

Analog Power - VA*Pin 21, Input**Function:*

Power for the analog and reference circuits. Typically 5.0 VDC.

Analog Ground - AGND*Pin 22, Input**Function:*

Analog ground reference.

Analog Output - AOUT1, AOUT2, AOUT3, AOUT4, AOUT5 and AOUT6*Pins 23, 24, 25, 26, 27, 28, Outputs**Function:*

Analog outputs from the DACs. The full scale analog output level is specified in the Analog Characteristics specifications table. The amplitude of the outputs is controlled by the Digital Volume Control registers VOL6 - VOL1.

PARAMETER DEFINITIONS

Dynamic Range

The ratio of the full scale RMS value of the signal to the RMS sum of all other spectral components over the specified bandwidth. Dynamic range is a signal-to-noise measurement over the specified bandwidth made with a -60 dBFS signal. 60 dB is then added to the resulting measurement to refer the measurement to full scale. This technique ensures that the distortion components are below the noise level and do not effect the measurement. This measurement technique has been accepted by the Audio Engineering Society, AES17-1991, and the Electronic Industries Association of Japan, EIAJ CP-307.

Total Harmonic Distortion + Noise

The ratio of the RMS value of the signal to the RMS sum of all other spectral components over the specified bandwidth (typically 20 Hz to 20 kHz), including distortion components. Expressed in decibels. ADCs are measured at -1dBFS as suggested in AES 17-1991 Annex A.

Idle Channel Noise / Signal-to-Noise-Ratio

The ratio of the RMS analog output level with 1 kHz full scale digital input to the RMS analog output level with all zeros into the digital input. Measured A-weighted over a 10 Hz to 20 kHz bandwidth. Units in decibels. This specification has been standardized by the Audio Engineering Society, AES17-1991, and referred to as Idle Channel Noise. This specification has also been standardized by the Electronic Industries Association of Japan, EIAJ CP-307, and referred to as Signal-to-Noise-Ratio.

Total Harmonic Distortion (THD)

THD is the ratio of the test signal amplitude to the RMS sum of all the in-band harmonics of the test signal. Units in decibels.

Interchannel Isolation

A measure of crosstalk between channels. Measured for each channel at the converter's output with no signal to the input under test and a full-scale signal applied to the other channel. Units in decibels.

Frequency Response

A measure of the amplitude response variation from 20Hz to 20 kHz relative to the amplitude response at 1 kHz. Units in decibels.

Interchannel Gain Mismatch

For the ADCs, the difference in input voltage that generates the full scale code for each channel. For the DACs, the difference in output voltages for each channel with a full scale digital input. Units are in decibels.

Gain Error

The deviation from the nominal full scale output for a full scale input.

Gain Drift

The change in gain value with temperature. Units in ppm/°C.

Offset Error

For the ADCs, the deviation in LSBs of the output from mid-scale with the selected input grounded. For the DACs, the deviation of the output from zero (relative to CMOUT) with mid-scale input code. Units are in volts.

PACKAGE DIMENSIONS

28L SSOP PACKAGE DRAWING

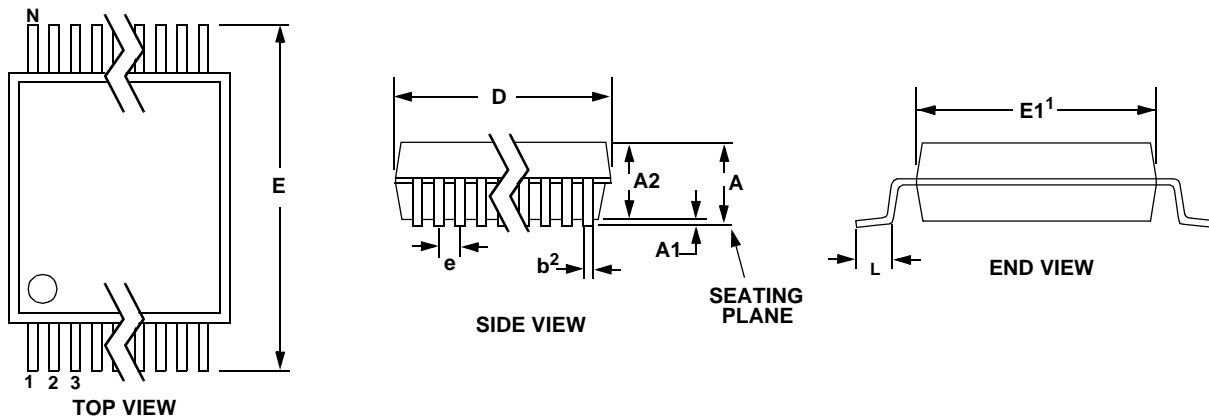

DIM	INCHES		MILLIMETERS		NOTE
	MIN	MAX	MIN	MAX	
A	--	0.084	--	2.13	
A1	0.002	0.010	0.05	0.25	
A2	0.064	0.074	1.62	1.88	
b	0.009	0.015	0.22	0.38	2,3
D	0.390	0.413	9.90	10.50	1
E	0.291	0.323	7.40	8.20	
E1	0.197	0.220	5.00	5.60	1
e	0.022	0.030	0.55	0.75	
L	0.025	0.041	0.63	1.03	
∞	0°	8°	0°	8°	

- Notes:
1. "D" and "E1" are reference datums and do not include mold flash or protrusions, but do include mold mismatch and are measured at the parting line, mold flash or protrusions shall not exceed 0.20 mm per side.
 2. Dimension "b" does not include dambar protrusion/intrusion. Allowable dambar protrusion shall be 0.13 mm total in excess of "b" dimension at maximum material condition. Dambar intrusion shall not reduce dimension "b" by more than 0.07 mm at least material condition.
 3. These dimensions apply to the flat section of the lead between 0.10 and 0.25 mm from lead tips.

SMART
Analog™

This datasheet has been downloaded from:

www.DatasheetCatalog.com

Datasheets for electronic components.



LittleDiode supplies new, hard to find or obsolete electronic components and semiconductors all over the world.

With over two million different components listed you are sure to find the part you need.

Feel free to visit us today at our online store:

LittleDiode.com

Looking forward to providing you with the best possible service.