

FEATURES

- AC'97 1.03 Compatible
- Industry Leading Mixed Signal Technology
- 18-bit stereo full-duplex Codec with fixed 48 kHz sampling rate
- Four analog line-level stereo inputs for connection from LINE IN, CD, VIDEO and AUX
- Two analog line-level mono inputs for speaker-phone and internal PC Beeper
- Mono microphone input switchable from two external sources
- High quality differential CD input
- Dual Stereo line level outputs
- Extensive power management support
- Meets or exceeds Microsoft's® PC'97 and PC'98 audio performance requirements.

ORDERING INFO

CS4297-KQ, 48-pin TQFP, 9x9x1 mm
 CS4297-JQ, 48-pin TQFP, 9x9x1 mm

CrystalClear™
SoundFusion™ Audio
Codec '97

DESCRIPTION

The CS4297 is a AC'97 1.03 compatible stereo audio Codec designed for PC multimedia systems. Using the industry leading CrystalClear delta-sigma and mixed signal technology, the CS4297 paves the way for PC'97-compliant desktop, portable, and entertainment PCs, where high-quality audio is required.

The CS4297, when coupled with a DC'97 PCI audio accelerator such as the CS4610, implements a cost-effective, superior quality, two-chip audio solution. The CS4297 Audio Codec '97 and CS4610 PCI Audio Accelerator are the first members of the SoundFusion family of advanced PCI audio products for next generation multimedia PCs.

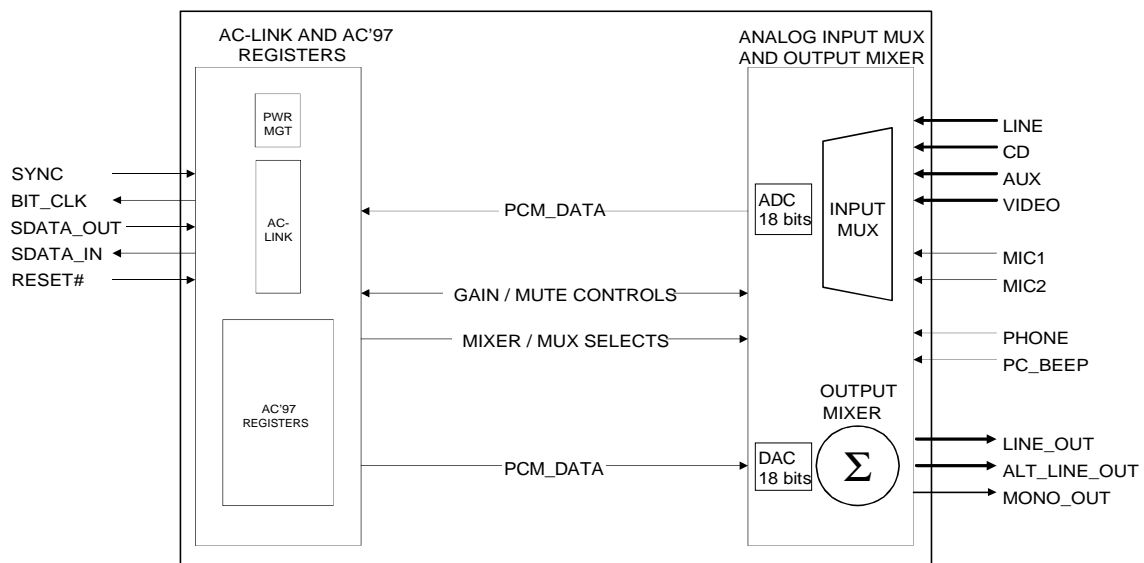

TABLE OF CONTENTS

CHARACTERISTICS AND SPECIFICATIONS.....	4
Analog Characteristics	4
Mixer Characteristics.....	5
Absolute Maximum Ratings	5
Recommended Operating Conditions	5
Power Down States.....	6
Digital Filter Characteristics	6
Digital Characteristics	7
Serial Port Timing.....	7
Serial Port Timing.....	8
PARAMETER AND TERM DEFINITIONS	10
GENERAL DESCRIPTION	12
Overview	12
Digital Section	12
AC-Link	12
AC'97 Register Interface	12
Power Management	12
Analog Section	12
Output Mixer	12
Input Mux	12
Volume Control	12
AC'97 IMPLEMENTATION	13
DIGITAL HARDWARE DESCRIPTION	15
AC'97 AC-Link	15
AC-Link Protocol	15
AC-Link Serial Data Output Frame	15
Slot 0: Serial Data Output Slot Tags	16
Slot 1: AC'97 Register Address	16
Slot 2: AC'97 Register Write Data	17
Slot 3: Left Channel PCM Playback Data	17
Slot 4: Right Channel PCM Playback Data	17
AC-Link Audio Input Frame	18
Slot 0: Serial Data Input Slot Tag Bits	18
Slot 1: Read-Back Address Port	19
Slot 2: Read-Back Data Port	19
Slot 3: Left Channel PCM Capture Data	19
Slot 4: Right Channel PCM Capture Data	20
AC-Link Reset Modes	21
Cold AC'97 Reset	21
Warm AC'97 Reset	21
AC'97 Register Reset	21
AC-Link Protocol Violation - Loss of SYNC	21
REGISTER INTERFACE	22
Reset Register (Index 00h)	23
Master Volume (Index 02h)	23
Alternate Volume (Index 04h)	23
Master Mono Volume (Index 06h)	23
PC_BEEP Volume (Index 0Ah)	24
Phone_In Volume (Index 0Ch)	24
Microphone Volume (Index 0Eh)	24
Stereo Analog Mixer Input Gain Registers (Index 10 - 18h)	25

Input Mux Select Register (Index 1Ah)	25
Record Gain Register (Index 1Ch)	26
Record Gain Mix (Index 1Eh)	26
General Purpose Register (Index 20h)	26
Powerdown Control/Status Register (Index 26h)	27
Reserved Registers (Index 28h - 58h)	27
Crystal Revision and Fab ID Register (Index 5Ah)	27
Vendor Reserved Registers (Index 5C - 7Ah)	28
Vendor ID1 (Index 7Ch)	28
POWER MANAGEMENT	29
ANALOG HARDWARE DESCRIPTION	29
Line-Level Inputs	29
Microphone Level Inputs	30
Mono Inputs	30
Line Level Outputs	31
Miscellaneous Analog Signals	32
Power Supplies	32
GROUNDING AND LAYOUT	33
PERFORMANCE PLOTS	34
PIN DESCRIPTIONS.....	39
Digital I/O Pins	39
Analog I/O Pins	40
Filter and Reference Pins	42
Power Supplies	43
REFERENCES	43
PACKAGE DIMENSIONS.....	44

Contacting Cirrus Logic Support

For a complete listing of Direct Sales, Distributor, and Sales Representative contacts, visit the Cirrus Logic web site at:
<http://www.cirrus.com/corporate/contacts/>

Microsoft is a registered trademark of Microsoft Corporation in the United States and/or other countries.

Intel is a registered trademark of Intel Corporation.

Preliminary product information describes products which are in production, but for which full characterization data is not yet available. Advance product information describes products which are in development and subject to development changes. Cirrus Logic, Inc. has made best efforts to ensure that the information contained in this document is accurate and reliable. However, the information is subject to change without notice and is provided "AS IS" without warranty of any kind (express or implied). No responsibility is assumed by Cirrus Logic, Inc. for the use of this information, nor for infringements of patents or other rights of third parties. This document is the property of Cirrus Logic, Inc. and implies no license under patents, copyrights, trademarks, or trade secrets. No part of this publication may be copied, reproduced, stored in a retrieval system, or transmitted, in any form or by any means (electronic, mechanical, photographic, or otherwise) without the prior written consent of Cirrus Logic, Inc. Items from any Cirrus Logic website or disk may be printed for use by the user. However, no part of the printout or electronic files may be copied, reproduced, stored in a retrieval system, or transmitted, in any form or by any means (electronic, mechanical, photographic, or otherwise) without the prior written consent of Cirrus Logic, Inc. Furthermore, no part of this publication may be used as a basis for manufacture or sale of any items without the prior written consent of Cirrus Logic, Inc. The names of products of Cirrus Logic, Inc. or other vendors and suppliers appearing in this document may be trademarks or service marks of their respective owners which may be registered in some jurisdictions. A list of Cirrus Logic, Inc. trademarks and service marks can be found at <http://www.cirrus.com>.

ANALOG CHARACTERISTICS (Standard test conditions unless otherwise noted: $T_{\text{ambient}} = 25^{\circ}\text{C}$, $AV_{\text{dd}} = 5.0\text{ V} \pm 5\%$, $DV_{\text{dd}} = 3.3\text{ V} \pm 5\%$; 1 kHz Input Sine wave; Sample Frequency, $F_s = 48\text{ kHz}$; $Z_{\text{AL}} = 10\text{ k}\Omega/680\text{ pF}$ load $C_{\text{DL}} = 18\text{ pF}$ load (Note 1); Measurement bandwidth is 20 Hz - 20 kHz, 18-bit linear coding; Mixer registers set for unity gain.

Parameter (Note 2)	Symbol	Path (Note 3)	CS4297-KQ			CS4297-JQ			Unit
			Min	Typ	Max	Min	Typ	Max	
Full Scale Input Voltage									
Line Inputs		A-D	0.91	1.00	-	0.91	1.00	-	V_{RMS}
Mic Inputs (20 dB=0)		A-D	0.91	1.00	-	0.91	1.00	-	V_{RMS}
Mic Inputs (20 dB=1)		A-D	0.091	0.10	-	0.091	0.10	-	V_{RMS}
Full Scale Output Voltage									
Line, Alternate Line, and Mono Outputs		D-A	0.91	1.0	1.13	0.91	1.0	1.13	V_{RMS}
Frequency Response (Note 4)	FR								
Analog $A_c = \pm 0.5\text{ dB}$		A-A	20	-	20,000	20	-	20,000	Hz
DAC $A_c = \pm 0.5\text{ dB}$		D-A	20	-	20,000	20	-	20,000	Hz
ADC $A_c = \pm 0.5\text{ dB}$		A-D	20	-	20,000	20	-	20,000	Hz
Dynamic Range	DR								
Stereo Analog inputs to LINE_OUT		A-A	90	95	-	-	90	-	dB FS A
Mono Analog inputs to LINE_OUT		A-A	85	90	-	-	85	-	dB FS A
DAC Dynamic Range		D-A	85	90	-	-	87	-	dB FS A
ADC Dynamic Range		A-D	85	90	-	-	85	-	dB FS A
DAC SNR (-20 dB FS input w/ CCIR-RMS filter on output)	SNR	D-A	-	63	-	-	-	-	dB
Total Harmonic Distortion + Noise (-3 dB FS input signal):	THD+N								
Line/Alternate Line Output		A-A	-	-94	-80	-	-	-74	dB FS A
DAC		D-A	-	-86	-80	-	-	-74	dB FS A
ADC (all inputs except phone/mic)		A-D	-	-87	-80	-	-	-74	dB FS A
ADC (phone/mic)		A-D	-	-87	-74	-	-	-74	dB FS A
Power Supply Rejection Ratio (1 kHz, $0.5 V_{\text{RMS}}$ w/ 5 V DC offset)(Note 4)			40	60	-	-	40	-	dB
Interchannel Isolation			70	87	-	-	87	-	dB
Spurious Tone (Note 4)			-	-100	-	-	-100	-	dB FS
Input Impedance (Note 4)			10	-	-	10	-	-	k Ω
External Load Impedance			10	-	-	10	-	-	k Ω
Output Impedance (Note 4)			-	730	-	-	730	-	Ω
Input Capacitance (Note 4)			-	5	-	-	5	-	pF
V_{refout}			2.0	2.3	2.5	2.0	2.3	2.5	V

- Notes: 1. Z_{AL} refers to the analog output pin loading and C_{DL} refers to the digital output pin loading.
2. Parameter definitions are given in the *Parameter and Term Definitions* section.
3. Path refers to the signal path used to generate this data. These paths are defined in the *Parameter and Term Definitions* section.
4. This specification is guaranteed by silicon characterization, it is not production tested.

MIXER CHARACTERISTICS (for CS4297-KQ only)

Parameter	Min	Typ	Max	Unit
Mixer Gain Range Span				
Line In, Aux, CD, Video, Mic1 Mic2, Phone, PC Beep	-	46.5	-	dB
Line Out, Alternate Line Out, Mono Out	-	94.5	-	dB
Step Size				
All volume controls except PC Beep	-	1.5	-	dB
PC Beep	-	3.0	-	dB

ABSOLUTE MAXIMUM RATINGS (AVss1 = AVss2 = DVss1 = DVss2 = 0 V)

Parameter	Min	Typ	Max	Unit
Power Supplies				
+3.3 V Digital	-0.3	-	6.0	V
+5 V Digital	-0.3	-	6.0	V
Analog	-0.3	-	6.0	V
Total Power Dissipation (Supplies, Inputs, Outputs)	-	210	450	mW
Input Current per Pin (Except Supply Pins)	-10	-	10	mA
Output Current per Pin (Except Supply Pins)	-15	-	15	mA
Analog Input voltage	-0.3	-	AVdd+ 0.3	V
Digital Input voltage	-0.3	-	DVdd + 0.3	V
Ambient Temperature (Power Applied)	-55	-	110	°C
Storage Temperature	-65	-	150	°C

RECOMMENDED OPERATING CONDITIONS (AVss1 = AVss2 = DVss1 = DVss2 = 0 V)

Parameter	Symbol	Min	Typ	Max	Unit
Power Supplies					
+3.3 V Digital	DVdd1, DVdd2	3.135	3.3	3.465	V
+5 V Digital	DVdd1, DVdd2	4.75	5	5.25	V
Analog	AVdd1, AVdd2	4.75	5	5.25	V
Operating Ambient Temperature		0	-	70	°C

POWER DOWN STATES

Parameter		Min	Typ	Max	Unit
Full Power	3.3 V digital		12.7		mA
	5 V digital		21.4		
	5 V analog	-	35.0	-	
ADCs and Input Mux Powerdown (PR0)	3.3 V digital		5.32		mA
	5 V digital		9.80		
	5 V analog	-	23.1	-	
DACs Powerdown (PR1)	3.3 V digital		9.25		mA
	5 V digital		16.0		
	5 V analog	-	30.0	-	
Analog Mixer Powerdown, Vref on (PR2)	3.3 V digital		9.20		mA
	5 V digital		16.0		
	5 V analog	-	10.7	-	
Analog Mixer Powerdown, Vref off (PR3)	3.3 V digital		5.30		mA
	5 V digital		9.80		
	5 V analog	-	-0.00	-	
AC-Link Powerdown (PR4)	3.3 V digital		3.30		mA
	5 V digital		6.92		
	5 V analog	-	23.0	-	
Internal Clock Disable (PR5)	3.3 V digital		0.004		mA
	5 V digital		0.005		
	5 V analog	-	0.001	-	
Alternate Line Output Buffer Powerdown (PR6)	3.3 V digital		5.30		mA
	5 V digital		9.80		
	5 V analog	-	20.3	-	

DIGITAL FILTER CHARACTERISTICS

Parameter	CS4297-KQ			CS4297-JQ			Unit
	Min	Typ	Max	Min	Typ	Max	
Transition Band	$0.4 \times F_s$	-	$0.6 \times F_s$	$0.4 \times F_s$	-	$0.6 \times F_s$	Hz
Stop Band	$0.6 \times F_s$	-	-	$0.6 \times F_s$	-	-	Hz
Stop Band Rejection (Note 4, 5)	74	-	-	74	-	-	dB
Out-of-Band Energy (Note 6)	-	-82	-	-	-40	-	dB
Group Delay (Note 4)	-	-	1	-	-	1	ms

- Notes: 5. Stop Band rejection determines filter requirements. Out-of-band rejection determines audible noise.
6. The integrated Out-of-Band generated by the DAC process, during normal PCM audio playback, over a bandwidth 28.8 kHz to 100 kHz, with respect to a 1 V_{RMS} DAC output.

DIGITAL CHARACTERISTICS (AVss = DVss = 0 V (See Grounding and Layout section))

Parameter	Symbol	Min	Typ	Max	Unit
Low level input voltage	V_{il}	-	-	0.16 x DVdd	V
High level input voltage	V_{ih}	0.40 x DVdd	-	-	V
High level output voltage	V_{oh}	0.70 x DVdd	0.99 x DVdd	-	V
Low level output voltage	V_{ol}	-	0.03	0.10 x DVdd	V
Input Leakage Current (AC-link inputs)		-10	-	10	μ A
Output Leakage Current (Tri-stated AC-link outputs)		-10	-	10	μ A
Output buffer drive current (Note 4)		-	100	400	μ A

SERIAL PORT TIMING

Parameter	Symbol	Min	Typ	Max	Unit
RESET Timing					
DVdd 90% maximum value to RESET# inactive pre-delay (Note 4)	$T_{Vdd2rst\#}$	1.5	-	-	ms
RESET# active low pulse width	T_{rst_low}	1.0	-	-	μ s
RESET# inactive to BIT_CLK start-up delay	$T_{rst2clk}$	-	42.7	-	ms
1st SYNC active to CODEC READY set	$T_{sync2crd}$	-	40.6	-	μ s
Clocks					
BIT_CLK frequency		-	12.288	-	MHz
BIT_CLK period	T_{clk_period}	-	81.4	-	ns
BIT_CLK output jitter (depends on XTAL_IN source)		-	-	750	ps
BIT_CLK high pulse width	T_{clk_high}	-	40.7	-	ns
BIT_CLK low pulse width	T_{clk_low}	-	40.7	-	ns
SYNC frequency		-	48	-	kHz
SYNC period	T_{sync_period}	-	20.8	-	μ s
SYNC high pulse width	T_{sync_high}	-	1.3	-	μ s
SYNC low pulse width	T_{sync_low}	-	19.5	-	μ s
SYNC active to RESET# inactive pre-delay	$T_{rst2sync}$	-	-	250	ms
Data Setup and Hold					
Output Propagation delay from rising edge of BIT_CLK	T_{prop}	-	6	8	ns
Output hold from falling edge of BIT_CLK	T_{ohold}	5	-	-	ns
Input setup time from falling edge of BIT_CLK	T_{isetup}	10	-	-	ns
Input hold time from falling edge of BIT_CLK	T_{ihold}	0	-	-	ns
Input Signal rise time	T_{irise}	2	-	6	ns
Input Signal fall time	T_{ifall}	2	-	6	ns
Output Signal rise time (Note 4)	T_{ofall}	2	4	6	ns
Output Signal fall time (Note 4)	T_{ofall}	2	4	6	ns

SERIAL PORT TIMING (Continued)

Misc. Timing Parameters					
End of Slot 2 to BIT_CLK, SDATA_IN low (PR4)	T_{s2_pdown}	-	16.24	16.36	μs
SYNC pulse width (PR4)	T_{sync_pr4}	1.0	-	-	μs
SYNC inactive (PR4) to BIT_CLK start-up delay	$T_{sync2clk}$	162.8	244	-	ns
Setup to trailing edge of RESET# (test modes) (Note 4)	$T_{setup2rst}$	15	-	-	ns
Rising edge of RESET# to Hi-Z delay (Note 4)	T_{off}	-	-	25	ns

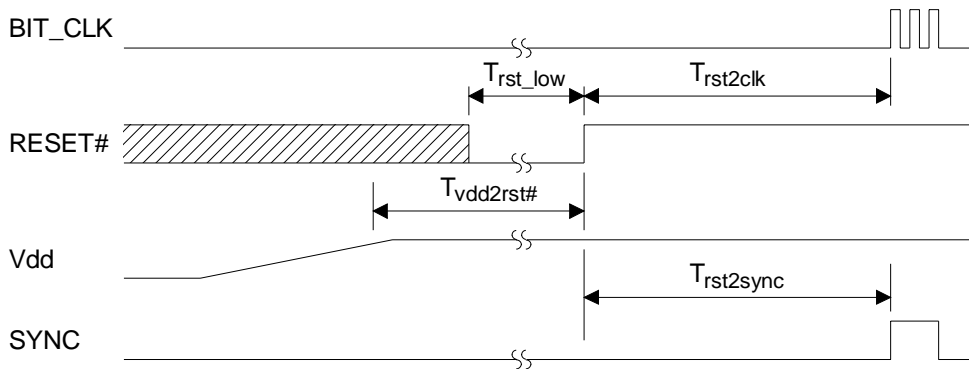
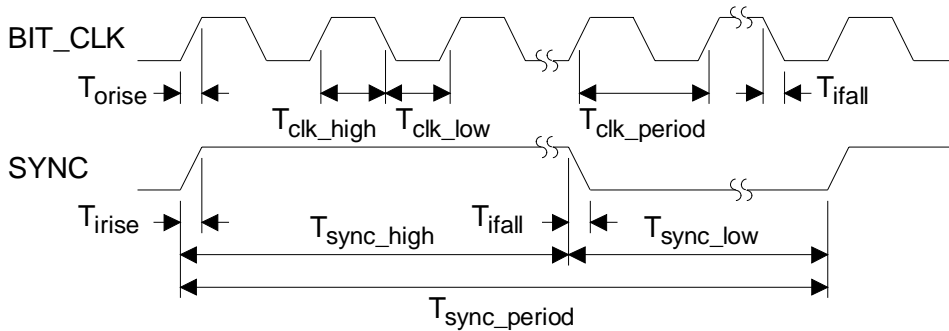
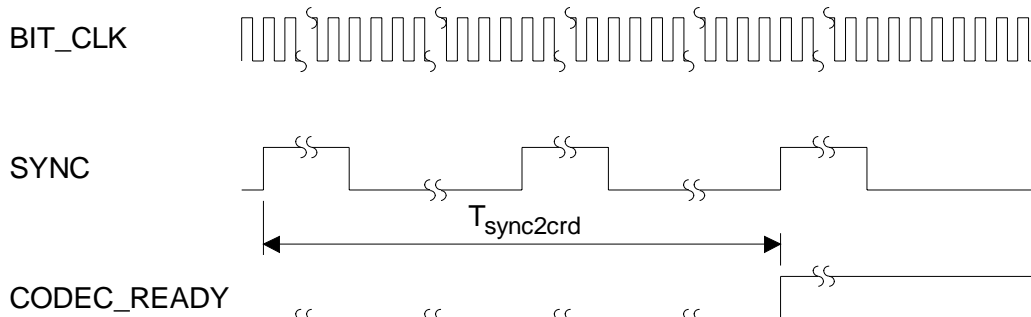

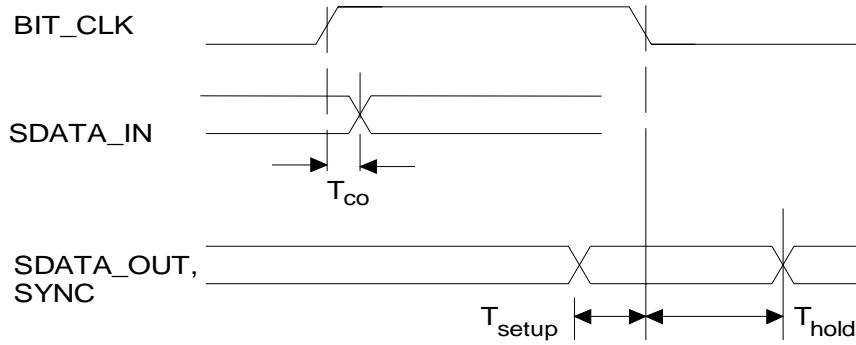
Power Up Timing

Clocks

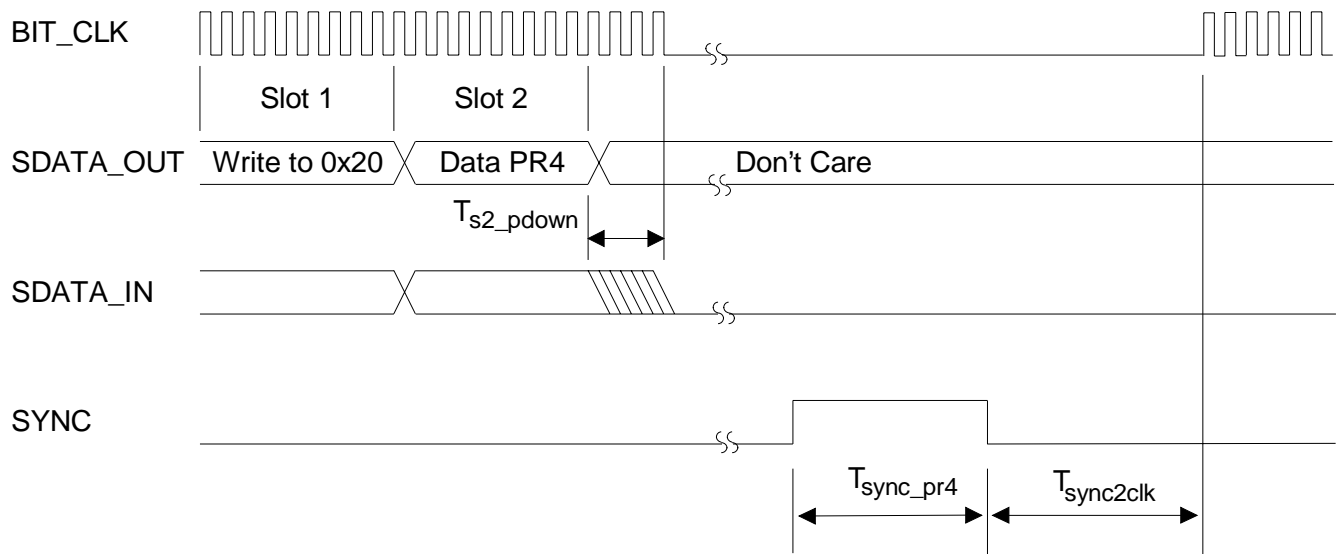
Codec Ready from Startup or Fault Condition

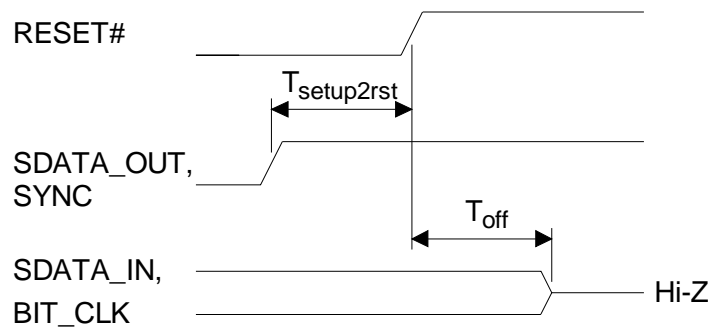

Data Setup and Hold



PR4 Powerdown



Test Mode

PARAMETER AND TERM DEFINITIONS

AC'97 Specification

Refers to the Audio Codec '97 Component Specification Ver 1.03 published by Intel® Corporation [1].

AC'97 Controller

Refers to the control chip which interfaces to the CS4297's AC-Link. This has been also called "DC'97" [1].

'set'

Refers to a digital value of Vcc, "1", or "high".

'clear' or 'cleared'

Refers to a digital value of GND, "0" or "low".

AC'97 Registers

Refers to the 64-field register map defined in the AC'97 Specification.

ADC

Refers to a single Analog-to-Digital converter in the CS4297. "ADCs" refers to the stereo pair of Analog-to-Digital converters.

DAC

A single Digital-to-Analog converter in the CS4297. "DACs" refers to the stereo pair of Digital-to-Analog converters.

Codec

Refers to the set of ADCs, DACs, and Analog mixer portions of the CS4297.

FFT

Fast Fourier Transform.

Resolution

The number of bits in the output words to the DACs, and in the input words to the ADCs.

Differential Nonlinearity

The worst case deviation from the ideal code width. Units in LSB.

dB FS A

dB FS is defined as dB relative to full-scale. The "A" indicates an A weighting filter was used.

Frequency Response (FR)

FR is the deviation in signal level versus frequency. The 0 dB reference point is 1 kHz. The amplitude corner, Ac, lists the maximum deviation in amplitude above and below the 1 kHz reference point. The listed minimum and maximum frequencies are guaranteed to be within the Ac from minimum frequency to maximum frequency inclusive.

Dynamic Range (DR)

DR is the ratio of the RMS full-scale signal level divided by the RMS sum of the noise floor, in the presence of a signal, available at any instant in time (no change in gain settings between measurements). Measured over a 20 Hz to 20 kHz bandwidth with units in dB FS A.

Total Harmonic Distortion plus Noise (THD+N)

THD+N is the ratio of the RMS sum of all non-fundamental frequency components, divided by the RMS full-scale signal level. It is tested using a -3 dB FS input signal and is measured over a 20 Hz to 20 kHz bandwidth with units in dB FS A.

Signal to Noise Ratio (SNR)

SNR, similar to DR, is the ratio of an arbitrary sinusoidal input signal to the RMS sum of the noise floor, in the presence of a signal. It is measured over a 20 Hz to 20 kHz bandwidth with units in dB.

Interchannel Isolation

The amount of 1 kHz signal present on the output of the grounded AC-coupled line input channel with 1 kHz 0 dB signal present on the other line input channel. Units in dB.

Interchannel Gain Mismatch

For the ADCs, the difference in input voltage to get an equal code on both channels. For the DACs, the difference in output voltages for each channel when both channels are fed the same code. Units in dB.

PATHS: [4]

A-D: Analog in, through the ADC, onto the serial link.

D-A: Serial interface inputs through the DAC to the analog output

A-A: Analog in to Analog out (analog mixer)

GENERAL DESCRIPTION

Overview

The CS4297 is a mixed-signal serial Codec based on the AC'97 Specification. It is designed to be paired with a digital controller, typically located on the PCI bus. The AC'97 Controller is responsible for all communications between the CS4297 and the rest of the system. The CS4297 functions as an analog mixer, a stereo ADC, a stereo DAC, and a control and digital audio stream interface to the AC'97 Controller.

The CS4297 contains two distinct functional sections: Digital and Analog. The Digital section includes the AC-Link registers, power management support, SYNC detection circuitry, and AC-Link serial port interface logic. The Analog section includes the analog input multiplexor (mux), stereo output mixer, mono output mixer, stereo ADCs, stereo DACs, and analog volume controls.

Digital Section

AC-Link

The AC-Link is the 5-wire digital interface to the AC'97 Controller chip. The CS4297 generates the BIT_CLK and the SDATA_IN signals. The AC'97 Controller must drive the SYNC, SDATA_OUT and RESET# signals. Please refer to the AC-Link timing section for the timing characteristics of the interface. The interface uses the SYNC signal, which is synchronous with BIT_CLK, to align the data within the frame. The AC-Link signals may be referenced to either 5 Volts or 3.3 Volts. The CS4297 should use the same digital supply voltage as the AC'97 Controller chip.

AC'97 Register Interface

The CS4297 implements the AC'97 Registers in accordance with the AC'97 Specification. See the *Register Interface* section for details on the CS4297's register set.

Power Management

The CS4297 supports a number of different power down modes. They are accessed through register 0x26h of the CS4297 register interface. Please refer to the *Power Management* section of the data sheet.

Analog Section

Please refer to Figure 1, Mixer diagram, for a high level graphical representation of the CS4297 analog mixer structure.

Output Mixer

There are two output mixers on the CS4297. The stereo output mixer sums together the analog inputs to the CS4297 according to the settings in the volume control registers. The mono output mixer generates a monophonic sum of the left and right channels from the stereo output mixer. However, the mono output mixer does not include the PC_BEEP and PHONE signals which are included in the stereo output mix. The stereo output mix is sent to the LINE_OUT and ALT_LINE_OUT output pins of the CS4297. The mono output mix is sent to the MONO_OUT output pin on the CS4297.

Input Mux

The input multiplexor controls which analog input is sent to the ADCs. The output of the input mux is converted to stereo 18-bit digital PCM data and sent to the AC'97 Controller chip in Slots 3 and 4 of the AC-Link SDATA_IN signal.

Volume Control

The volume control registers of the AC'97 Register interface control analog input level to the input mixer, the master volume level, and the alternate

volume level. All analog volume controls, except PC_BEEP, implement controlled volume steps at nominally 1.5 dB per step. PC_BEEP uses 3 dB steps. The analog inputs allow a mixing range of +12 dB of signal gain to -34.5 dB of signal attenuation. The analog output volume controls allow from 0 dB to -94.5 dB of attenuation. The PC_BEEP input volume control allows from 0 dB to -45 dB of attenuation.

AC'97 IMPLEMENTATION

The CS4297 implements an AC'97 compliant design as defined in the Intel Audio Codec 97 Specification Version 1.03. Due to certain design trade-offs and implementation decisions, the CS4297 dif-

fers from the AC'97 Specification in a few minor ways. The following list captures the specification deviations and the implementation decisions made to resolve ambiguities.

1. The rising edge of RESET# must occur at least 1.5 ms after the digital power supply DVdd reaches 90% of maximum value.
2. The digital input voltage threshold levels are specified as percentages of the Vdd digital power supply and are TTL level compatible. Min $V_{ih} = 0.4 \times V_{dd}$, Max $V_{il} = 0.16 \times V_{dd}$.
3. The delay between setting the PR4 bit to powering down the AC-Link interface is implemented as 16.24 μ s.

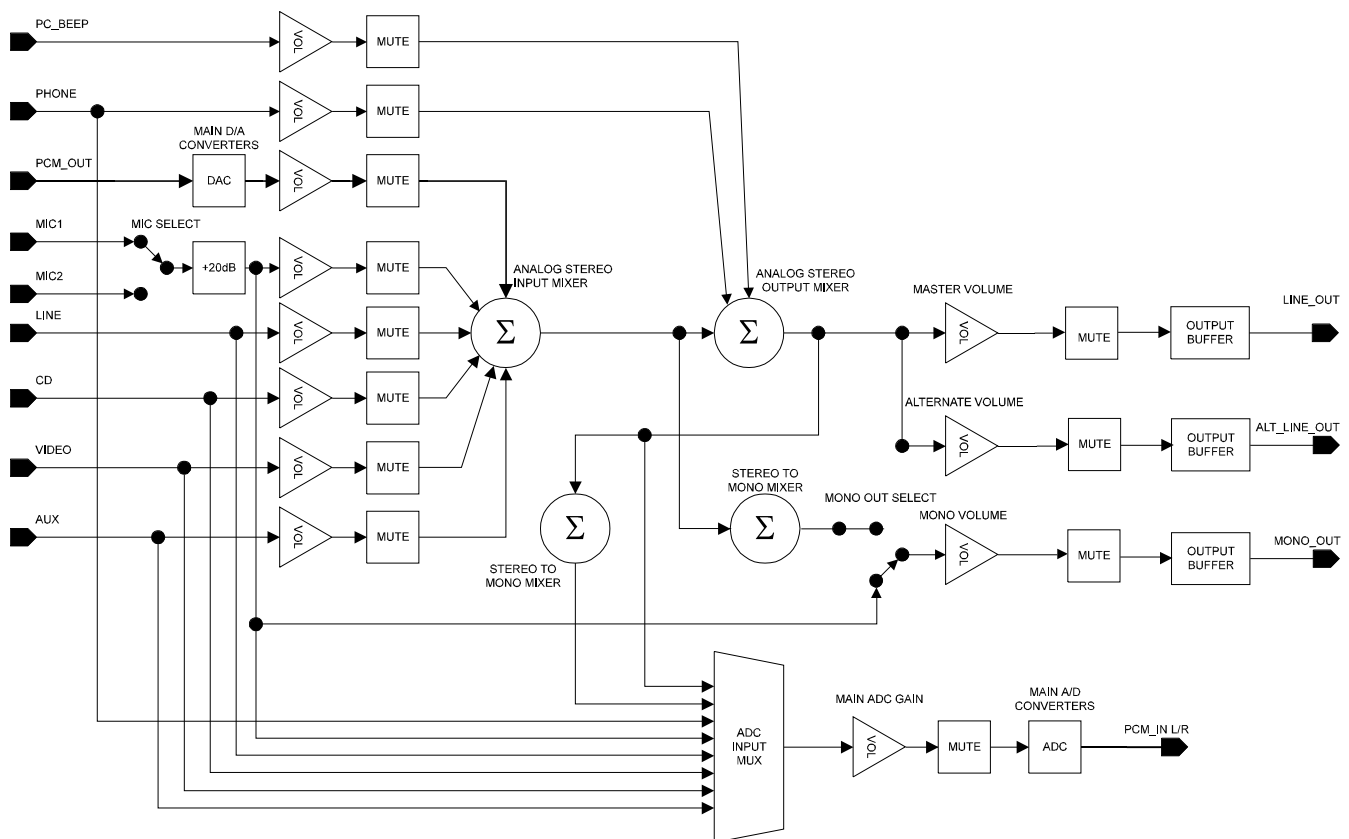

Figure 1. Mixer Diagram

4. The digital outputs are specified with a 18 pF capacitive load.
5. The nominal Vrefout level is 2.2 V.
6. All analog mixer input and output paths are designed to achieve greater than 90 dBFS Dynamic Range.
7. All stereo-to-mono mixer stages contain a scale factor of -6 dB to prevent output clipping of the summed mono signal.
8. When the analog mixer is powered down, the control registers for Record Select and Record Gain are frozen. The analog mixer stage must be powered up to gain access to these registers.
9. The Headphone Output pins have been implemented as an Alternate Line Output. These pins must drive loads greater than 10 k Ω , just as the Line Outputs.
10. Reserved bits in the AC'97 serial data input stream may return a 'set' or a 'cleared' value.
11. The Vref pin defined in the AC'97 Specification has been renamed to REFFLT. This pin is used for internal filtering and should not be used as an external circuit bias voltage. The Vrefout pin is used to supply biasing voltages to external analog circuitry. This pin is not capable of supplying 5 mA of bias current as the specification indicates.

DIGITAL HARDWARE DESCRIPTION

AC'97 AC-Link

The AC-Link is the serial connection between the AC'97 Controller and the CS4297. The interface consists of 5 signal lines (2 data, 2 clocks, and 1 reset). The basic connections of the link are shown in Figure 2. The signals will be explained in detail below.

AC-Link Protocol

The CS4297 serial interface is designed according to the AC'97 Specification to allow connection to any AC'97 Controller. An AC-Link audio frame is divided into 13 'slots'; 1 16-bit slot and 12 20-bit slots. During each audio frame, data is passed bi-directionally between the CS4297 and the AC'97 Controller.

AC-Link Serial Data Output Frame

For the serial data output frame, the SYNC, BIT_CLK, and SDATA_OUT signals are used. In the serial data output frame, data is passed on the SDATA_OUT pin FROM the AC'97 Controller TO the CS4297. In Figure 3 and in the following Frame Slot definitions, the position of each bit location within the frame is noted. The first bit posi-

tion in a new serial data frame is F0 and the last bit position in the serial data frame is F255.

When SYNC goes active (high) and is sampled active by the CS4297 (on the falling edge of BIT_CLK), both devices are synchronized to a new serial data frame. The data on the SDATA_OUT pin at this clock edge is the final bit of the previous serial data frame's data. On the next rising edge of BIT_CLK, the first bit of slot 0 is driven by the AC'97 Controller on the SDATA_OUT pin. The CS4297 latches in this data, as the first bit of the frame, on the next falling edge of the BIT_CLK clock signal.

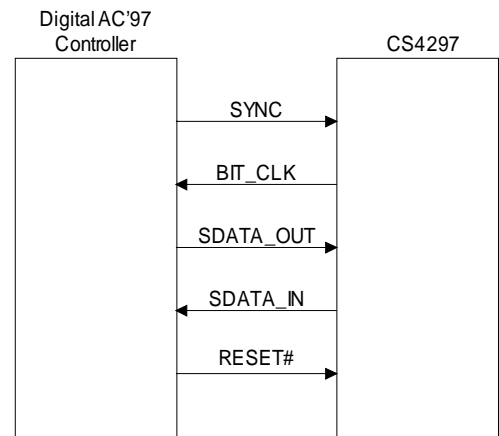

Figure 2. AC-link Connections

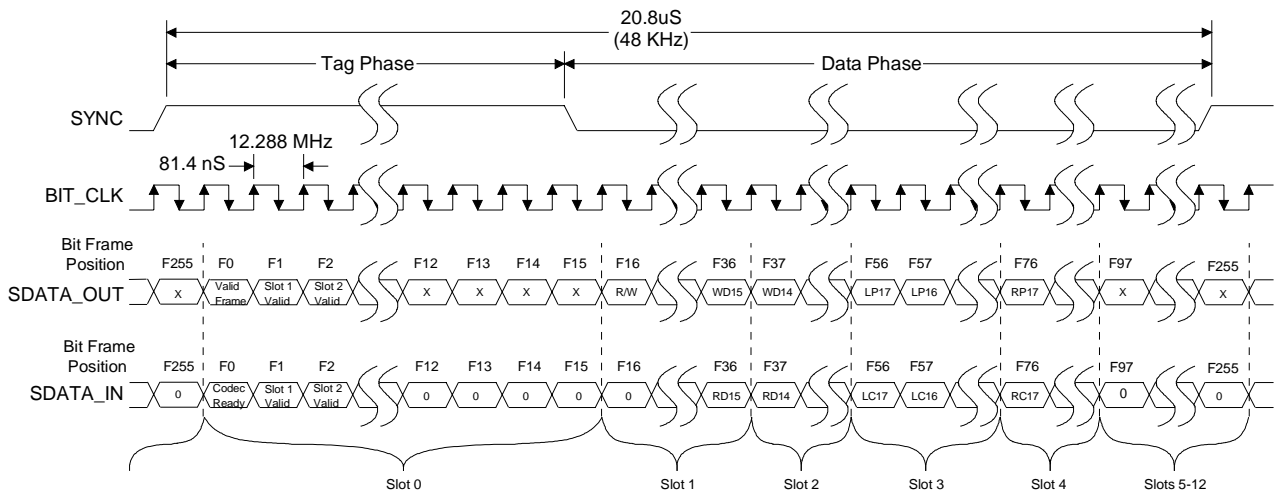

Figure 3. AC-Link Input and Output Framing

Slot 0: Serial Data Output Slot Tags

The first slot, Slot 0, is a 16-bit slot which contains information about the validity of data for the remaining 12 slots. The 16 bits of this slot are defined as:

F0	F1	F2	F3	F4	F5	F6	F7	F8	F9	F10	F11	F12	F13	F14	F15
Bit 15	14	13	12	11	10	9	8	7	6	5	4	3	2	1	0
Valid Frame	Slot 1 Valid	Slot 2 Valid	Slot 3 Valid	Slot 4 Valid	Not Used										

Valid Frame - Bit 15 determines if any of the following slots contain valid data. If this bit is 'set', at least one of the other 12 slots contain valid data. If this bit is 'cleared', the remainder of the frame will be ignored.

Slot 1 Valid - Bit 14 indicates the validity of data in the serial data output Slot 1. If this bit is 'set', Slot 1 contains valid data. If this bit is 'cleared', Slot 1 will be ignored.

Slot 2 Valid - Bit 13 indicates the validity of data in the serial data output Slot 2. If this bit is 'set', Slot 2 contains valid data. If this bit is 'cleared', Slot 2 will be ignored.

Slot 3 Valid - Bit 12 indicates the validity of data in the serial data output Slot 3. If this bit is 'set', Slot 3 contains valid data. If this bit is 'cleared', Slot 3 will be ignored.

Slot 4 Valid - Bit 11 indicates the validity of data in the serial data output Slot 4. If this bit is 'set', Slot 4 contains valid data. If this bit is 'cleared', Slot 4 will be ignored.

Slot 0 bits 10 through 0 represent unimplemented data slots in the CS4297 and will be ignored.

The input PCM data to the CS4297 on the SDATA_OUT pin is shifted out MSB justified (most significant bit of the actual data of the 20-bit slots). In any case where there are less than 20-bits of valid data for a slot (i.e.: 18-bit PCM data in a 20-bit slot), the trailing bits of the slot must be 'cleared' by the AC'97 Controller. For Slots 5 - 12, the AC'97 Controller should 'clear' each bit in each frame, however data in these slots will be ignored.

Slot 1: AC'97 Register Address

Slot 1 indicates the Register Address of the current frame's register access. The 20 bits of this slot are defined as:

F16	F17	F18	F19	F20	F21	F22	F23	F24	F25	F26	F27	F28	F29	F30	F31	F32	F33	F34	F35
Bit 19	18	17	16	15	14	13	12	11	10	9	8	7	6	5	4	3	2	1	0
R/W	RI6	RI5	RI4	RI3	RI2	RI1	RI0	Reserved											

Table 1. Command Address Port Bit Definition

R/W - Bit 19 is the Read/Write bit. When this bit is 'set', a read of the AC'97 Register specified by the Register Index will occur. When the bit is 'cleared', a write will occur. In both cases, register accesses only occur when the Slot Valid bit 14 of Slot 0 (F1) corresponding to Slot 1 is 'set'.

RI6 - RI0 - Bits 18-12 contain the 7-bit register index to the AC'97 Registers in the CS4297. All registers are defined at word addressable boundaries. Bit 12 will be saved for historic purposes but is not decoded.

Bits 11-0 are reserved and should always be 'cleared' the AC'97 Controller.

Slot 2: AC'97 Register Write Data

Slot 2 indicates the Register Data of the current frame's register write access. The 20 bits of this slot are defined as:

F36	F37	F38	F39	F40	F41	F42	F43	F44	F45	F46	F47	F48	F49	F50	F51	F52	F53	F54	F55
Bit 19	18	17	16	15	14	13	12	11	10	9	8	7	6	5	4	3	2	1	0
WD15	WD14	WD13	WD12	WD11	WD10	WD9	WD8	WD7	WD6	WD5	WD4	WD3	WD2	WD1	WD0	Reserved			

WD15 - WD0 - Bits 19-4 contain the 16-bit value to be written to the register. Bits 3-0 are ignored, but should always be 'cleared'. If the access is a read, this slot is ignored. The data in Slot 2 will only be valid when the Slot Valid bit 13 of Slot 0 (F2) corresponding to Slot 2 is 'set'.

NOTE: For any write to an AC'97 Register, the write is defined to be an 'atomic' access. This means that when the slot valid bit for Slot 1 is 'set', the slot valid bit for Slot 2 should always be 'set' during the same audio frame. No write access may be split across 2 frames.

Slot 3: Left Channel PCM Playback Data

Slot 3 contains the left channel data. The 20 bits of this slot are defined as:

F56	F57	F58	F59	F60	F61	F62	F63	F64	F65	F66	F67	F68	F69	F70	F71	F72	F73	F74	F75
Bit 19	18	17	16	15	14	13	12	11	10	9	8	7	6	5	4	3	2	1	0
LP17	LP16	LP15	LP14	LP13	LP12	LP11	LP10	LP9	LP8	LP7	LP6	LP5	LP4	LP3	LP2	LP1	LP0	Reserved	

LP17 - LP0 - This is the 18-bit PCM playback 2's compliment data for the left channel DAC in the CS4297. The PCM playback data will be taken from the most significant 18 of the 20 bits in the slot. The least significant 2 bits will be ignored. Any PCM data from the AC'97 Controller that is not at least 18-bits should be left justified in Slot 3 and dithered or zero-padded in the unused bit positions.

Slot 4: Right Channel PCM Playback Data

Slot 4 contains the right channel data. The 20 bits of this slot are defined as:

F76	F77	F78	F79	F80	F81	F82	F83	F84	F85	F86	F87	F88	F89	F90	F91	F92	F93	F94	F95
Bit 19	18	17	16	15	14	13	12	11	10	9	8	7	6	5	4	3	2	1	0
RP17	RP16	RP15	RP14	RP13	RP12	RP11	RP10	RP9	RP8	RP7	RP6	RP5	RP4	RP3	RP2	RP1	RP0	Reserved	

RP17 - RP0 - This is the 18-bit PCM playback 2's compliment data for the right channel DAC in the CS4297. The PCM playback data will be taken from the most significant 18 of the 20 bits in the slot. The least significant 2 bits will be ignored. Any PCM data from the AC'97 Controller that is not at least 18-bits should be left justified in Slot 4 and dithered or zero-padded in the unused bit positions.

AC-Link Audio Input Frame

An AC-Link serial data input frame uses the SYNC, BIT_CLK, and SDATA_IN signals are used. In the serial data input frame, data is passed on the SDATA_IN pin FROM the CS4297 TO the

AC'97 Controller. The data format for the input frame is very similar to the output frame. Synchronization of the CS4297 to the AC'97 Controller is performed in the same manner. Please refer to Figure 3 for the serial port timing waveform.

Slot 0: Serial Data Input Slot Tag Bits

The first slot, Slot 0, is a 16-bit slot which contains information about the validity of data for the remaining 12 slots. The 16 bits of this slot are defined as:

F0	F1	F2	F3	F4	F5	F6	F7	F8	F9	F10	F11	F12	F13	F14	F15
Bit 15	14	13	12	11	10	9	8	7	6	5	4	3	2	1	0
Codec Ready	Slot 1 Valid	Slot 2 Valid	Slot 3 Valid	Slot 4 Valid	Not Used										

Codec Ready - Bit 15 indicates the readiness of the CS4297's AC-Link and the AC'97 Control and Status Registers. Immediately after a Cold Reset this bit will be returned to the AC'97 Controller 'cleared'. Once the CS4297's clocks and voltages are stable, this bit will be set. Until the Codec Ready bit is 'set', no AC-Link transactions should be attempted by the AC'97 Controller.

NOTE: This Codec Ready bit does not indicate readiness of the DACs, ADCs, Vref, or any other analog function. Those must be checked in the Powerdown/Status Register by the AC'97 Controller. Any accesses to the CS4297 while this bit is 'cleared' will be ignored.

Slot 1 Valid - Bit 14 indicates the validity of data in the serial data input Slot 1. If this bit is 'set', Slot 1 contains valid data. If this bit is 'cleared', Slot 1 should be ignored by the AC'97 Controller.

Slot 2 Valid - Bit 13 indicates the validity of data in the serial data input Slot 2. If this bit is 'set', Slot 2 contains valid data. If this bit is 'cleared', Slot 2 should be ignored by the AC'97 Controller.

Slot 3 Valid - Bit 12 indicates the validity of data in the serial data input Slot 3. If this bit is 'set', Slot 3 contains valid data. If this bit is 'cleared', Slot 3 should be ignored by the AC'97 Controller.

Slot 4 Valid - Bit 11 indicates the validity of data in the serial data input Slot 4. If this bit is 'set', Slot 4 contains valid data. If this bit is 'cleared', Slot 4 should be ignored by the AC'97 Controller.

Slot 0 bits 10 through 0 represent unimplemented data slots in the CS4297 and should be ignored by the AC'97 Controller.

Slot 1: Read-Back Address Port

Slot 1 is the Read-Back Address Port. The Read-Back Address Port is used to echo the AC'97 Register address back to the AC'97 Controller when the CS4297 has been issued a read request from the previous frame. Included only for historical purposes, this address may be used by the AC'97 Controller to synchronize read accesses. The CS4297 will only echo the register index for a read access. Write accesses will not return valid data in Slot 1. The 20 bits of this slot are defined as:

F16	F17	F18	F19	F20	F21	F22	F23	F24	F25	F26	F27	F28	F29	F30	F31	F32	F33	F34	F35
Bit 19	18	17	16	15	14	13	12	11	10	9	8	7	6	5	4	3	2	1	0
0	RI6	RI5	RI4	RI3	RI2	RI1	RI0	0	0	0	0	0	0	0	0	0	0	0	0

RI6 - RI0 - Bits 18-12 contain the 7-bit register index to the AC'97 Registers in the CS4297.

All other undefined bits in Slot 1 will be returned by the CS4297 'cleared'.

Slot 2: Read-Back Data Port

Slot 2 is the Read-Back Data Port. The Read-Back Data Port contains the register data requested by the AC'97 Controller from the previous read request. It reflects the valid data bits from the 16-bit AC'97 Register being read. All read requests will return read addresses and data on the following serial data frame. The 20 bits of this slot are defined as:

F36	F37	F38	F39	F40	F41	F42	F43	F44	F45	F46	F47	F48	F49	F50	F51	F52	F53	F54	F55
Bit 19	18	17	16	15	14	13	12	11	10	9	8	7	6	5	4	3	2	1	0
RD15	RD14	RD13	RD12	RD11	RD10	RD9	RD8	RD7	RD6	RD5	RD4	RD3	RD2	RD1	RD0	0	0	0	0

WD15 - WD0 - Bits 19-4 contain the 16-bit AC'97 Register value returned to the AC'97 Controller by the CS4297. Bits 3-0 are undefined in Slot 2 and will be returned by the CS4297 'cleared'.

NOTE: The CS4297 implements bus-keeper logic for its 16-bit registers. Any read accesses from AC'97 Registers with undefined bits may return a 'set' or 'clear' value. The value returned depends on the state of that bit location from the previous access. No AC'97 Controller software dependencies should exist on the value of undefined AC'97 Register bits. For a list of the undefined bits in the AC'97 register map, see Table 2, Mixer Registers.

Slot 3: Left Channel PCM Capture Data

Slot 3 contains the left channel data. The 20 bits of this slot are defined as:

F56	F57	F58	F59	F60	F61	F62	F63	F64	F65	F66	F67	F68	F69	F70	F71	F72	F73	F74	F75
Bit 19	18	17	16	15	14	13	12	11	10	9	8	7	6	5	4	3	2	1	0
LP17	LP16	LP15	LP14	LP13	LP12	LP11	LP10	LP9	LP8	LP7	LP6	LP5	LP4	LP3	LP2	LP1	LP0	0	0

LP17 - LP0 - This is the 18-bit PCM 2's complement capture data from the left channel ADC in the CS4297. The PCM capture data is left justified in the most significant 18 of the 20 bits in the slot.

The least significant 2 bits will be 'cleared'.

Slot 4: Right Channel PCM Capture Data

Slot 4 contains the right channel data. The 20 bits of this slot are defined as:

F76	F77	F78	F79	F80	F81	F82	F83	F84	F85	F86	F87	F88	F89	F90	F91	F92	F93	F94	F95
Bit 19	18	17	16	15	14	13	12	11	10	9	8	7	6	5	4	3	2	1	0
RP17	RP16	RP15	RP14	RP13	RP12	RP11	RP10	RP9	RP8	RP7	RP6	RP5	RP4	RP3	RP2	RP1	RP0	0	0

RP17 - RP0 - This is the 18-bit PCM 2's compliment capture data from the right channel ADC in the CS4297. The PCM capture data is left justified in the most significant 18 of the 20 bits in the slot.

The least significant 2 bits will be 'cleared'.

Slots 5 through 12 are not implemented in the CS4297, and therefore will always be returned 'cleared' for all bits.

AC-Link Reset Modes

There are 3 methods to reset the CS4297. These are defined in the AC'97 Specification as 'Cold AC'97 Reset', 'Warm AC'97 Reset', and AC'97 Register Reset. A 'Cold AC'97 Reset' is required to restart the AC-Link when bit PR5 is 'set' in register (0x26).

Cold AC'97 Reset

A Cold Reset is performed simply by asserting RESET# in accordance with the minimum timing specifications in the Serial Port Timing section of the data sheet. Once de-asserted, all of the AC'97 Registers will be reset to their default power-on states and the BIT_CLK clock and SDATA_IN signals will be reactivated. The timing of power-up/reset events is discussed in detail in the *Power Management* section of the data sheet.

Warm AC'97 Reset

The CS4297 may also be reactivated when the AC-Link is powered down (refer to the PR4 bit description in the *Power Management* section of the data sheet) by a Warm Reset. A Warm Reset allows the AC-Link to be reactivated without losing information in the AC'97 Registers. Warm Reset is initiated when the SYNC signal is driven high for at least 1 μ s and then driven low in the absence of the BIT_CLK clock signal. The BIT_CLK clock will not restart until at least 2 normal BIT_CLK clock periods (± 162.8 ns) after the SYNC signal is de-asserted.

AC'97 Register Reset

The third reset mode provides a register reset to the CS4297. This is available only when the CS4297's AC-Link is active and the Codec Ready bit is 'set'. The Register Reset allows all user accessible registers in the CS4297 to be reset to their default, power-up values. A Register Reset occurs when any value is written to AC'97 Register 00h.

AC-Link Protocol Violation - Loss of SYNC

The CS4297 was designed to handle SYNC protocol violations. The following are situations where the SYNC protocol has been violated:

The SYNC signal is not sampled high for exactly 16 BIT_CLK clock cycles at the start of an audio frame.

The SYNC signal is not sampled high on the 256th BIT_CLK clock period after the previous SYNC assertion.

The SYNC signal goes active high before the 256th BIT_CLK clock period after the previous SYNC assertion.

Upon loss of synchronization with the AC'97 Controller, the CS4297 will mute all analog outputs and 'clear' the Codec Ready bit in the serial data input frame until 2 valid frames are detected. During this detection period, the CS4297 will ignore all register reads and writes and will discontinue the transmission of PCM capture data.

REGISTER INTERFACE

Reg Num	Name	D15	D14	D13	D12	D11	D10	D9	D8	D7	D6	D5	D4	D3	D2	D1	D0	Default
00h	Reset	0	0	0	0	0	0	0	1	0	1	0	1	0	0	0	0	0150h
02h	Master Volume	Mute	X	ML5	ML4	ML3	ML2	ML1	ML0	X	X	MR5	MR4	MR3	MR2	MR1	MR0	8000h
04h	Alternate Line Out Volume	Mute	X	ML5	ML4	ML3	ML2	ML1	ML0	X	X	MR5	MR4	MR3	MR2	MR1	MR0	8000h
06h	Master Volume Mono	Mute	X	X	X	X	X	X	X	X	X	MM5	MM4	MM3	MM2	MM1	MM0	8000h
08h	Reserved	0	0	0	0	0	0	0	0	0	0	0	0	0	0	0	0	0000h
0Ah	PC_BEEP Volume	Mute	X	X	X	X	X	X	X	X	X	X	PV3	PV2	PV1	PV0	X	0000h
0Ch	Phone Volume	Mute	X	X	X	X	X	X	X	X	X	X	GN4	GN3	GN2	GN1	GN0	8008h
0Eh	Mic Volume	Mute	X	X	X	X	X	X	X	X	20dB	X	GN4	GN3	GN2	GN1	GN0	8008h
10h	Line In Volume	Mute	X	X	GL4	GL3	GL2	GL1	GL0	X	X	X	GR4	GR3	GR2	GR1	GR0	8808h
12h	CD Volume	Mute	X	X	GL4	GL3	GL2	GL1	GL0	X	X	X	GR4	GR3	GR2	GR1	GR0	8808h
14h	Video Volume	Mute	X	X	GL4	GL3	GL2	GL1	GL0	X	X	X	GR4	GR3	GR2	GR1	GR0	8808h
16h	Aux Volume	Mute	X	X	GL4	GL3	GL2	GL1	GL0	X	X	X	GR4	GR3	GR2	GR1	GR0	8808h
18h	PCM Out Vol	Mute	X	X	GL4	GL3	GL2	GL1	GL0	X	X	X	GR4	GR3	GR2	GR1	GR0	8808h
1Ah	Record Select	X	X	X	X	X	SL2	SL1	SL0	X	X	X	X	X	SR2	SR1	SR0	0000h
1Ch	Record Gain	Mute	X	X	X	GL3	GL2	GL1	GL0	X	X	X	X	GR3	GR2	GR1	GR0	8000h
1Eh	Reserved	0	0	0	0	0	0	0	0	0	0	0	0	0	0	0	0	0000h
20h	General Purpose	0	0	0	0	0	0	MIX	MS	LPBK	0	0	0	0	0	0	0	0000h
22h	Reserved	0	0	0	0	0	0	0	0	0	0	0	0	0	0	0	0	0000h
24h	Reserved	0	0	0	0	0	0	0	0	0	0	0	0	0	0	0	0	0000h
26h	Powerdown Ctrl/Stat	0	PR6	PR5	PR4	PR3	PR2	PR1	PR0	0	0	0	0	REF	ANL	DAC	ADC	000Fh
28h	Reserved	0	0	0	0	0	0	0	0	0	0	0	0	0	0	0	0	0000h
..
5Ah	Crystal Revision and Fab ID	0	0	0	0	0	0	1	1	0	0	0	0	0	0	0	1	0301h
..
76h	Crystal Reserved	X	X	X	X	X	X	X	X	X	X	X	X	X	X	X	X	XXXXh
78h	Crystal Reserved	X	X	X	X	X	X	X	X	X	X	X	X	X	X	X	X	XXXXh
7Ah	Crystal Reserved	X	X	X	X	X	X	X	X	X	X	X	X	X	X	X	X	XXXXh
7Ch	Vendor ID1(CR)	0	1	0	0	0	0	1	1	0	1	0	1	0	0	1	0	4352h
7Eh	Vendor ID2(Y2)	0	1	0	1	1	0	0	1	0	0	0	0	0	0	1	1	5903h

Table 2. Mixer Registers

Reset Register (Index 00h)

Any write to this register causes a Register Reset of the AC'97 Registers to occur. This forces all registers to return to their default state. Reads from the Reset Register will return configuration information about the part. The CS4297 supports 18-bit DAC and ADC digital audio channels and the Headphone Output (in the form of the Alternate Line Output). The value read from this register will always be 0x0150h.

Master Volume (Index 02h)

The Master Volume control register controls the LINE_OUT signal's volume. Each register step corresponds to 1.5 dB volume adjustment, thus offering a range between 0 dB and 94.5 dB of attenuation.

D15	D14	D13	D12	D11	D10	D9	D8	D7	D6	D5	D4	D3	D2	D1	D0
Mute	X	ML5	ML4	ML3	ML2	ML1	ML0	X	X	MR5	MR4	MR3	MR2	MR1	MR0

Mute - The MSB of this register controls a master analog mute for the LINE_OUT_L and the LINE_OUT_R output signals.

ML5 - ML0 - These bits control the left channel's volume

MR5 - MR0 - These bits control the right channel's volume.

The default value for this register is 8000h, corresponding to 0 dB attenuation and mute on.

Alternate Volume (Index 04h)

The Alternate Volume control register is used to control the ALT_LINE_OUT signal's volume. Each register step corresponds to 1.5 dB volume adjustment, thus offering a range between 0 dB and 94.5 dB of attenuation.

D15	D14	D13	D12	D11	D10	D9	D8	D7	D6	D5	D4	D3	D2	D1	D0
Mute	X	ML5	ML4	ML3	ML2	ML1	ML0	X	X	MR5	MR4	MR3	MR2	MR1	MR0

Mute - The MSB of this register controls a master analog mute for the ALT_LINE_OUT_L and the ALT_LINE_OUT_R output signals.

ML5 - ML0 - These bits control the left channel's volume.

MR5 - MR0 - These bits control the right channel's volume.

The default value for this register is 8000h, corresponding to 0 dB attenuation and mute on.

Master Mono Volume (Index 06h)

The Master Mono Volume control register controls the MONO_OUT signal's volume. Each register step corresponds to 1.5 dB volume adjustment, thus offering a range between 0 dB and 94.5 dB of attenuation.

D15	D14	D13	D12	D11	D10	D9	D8	D7	D6	D5	D4	D3	D2	D1	D0
Mute	X	X	X	X	X	X	X	X	X	MM5	MM4	MM3	MM2	MM1	MM0

The MSB of this register controls a master analog mute for the MONO_OUT. Bits MM5 - MM0 of the register are used to control the actual volume levels.

The default value for this register is 8000h, corresponding to 0 dB attenuation and mute on.

PC_BEEP Volume (Index 0Ah)

D15	D14	D13	D12	D11	D10	D9	D8	D7	D6	D5	D4	D3	D2	D1	D0
Mute	X	X	X	X	X	X	X	X	X	X	PV3	PV2	PV1	PV0	X

The PC_BEEP Volume control register controls the mix of the PC_BEEP in the Analog Output Mixer. Each register step corresponds to 3.0 dB volume adjustment, thus offering a range between 0 dB and 45 dB of attenuation. The MSB of this register controls a master analog mute for the PC_BEEP. Bits PV3 - PV0 of the register control the actual volume levels.

NOTE: The 4 valid data bits for the PC_BEEP volume control are not aligned to the least significant bits of the register. Valid data bit 0 (PV0) corresponds to bit D1 of the register. Also, each step of the value (PV3 - PV0) corresponds to a 3 dB step in volume control, as opposed to all other gain controls, which have a 1.5 dB step size.

Also note that the default state of the mute bit (bit D15) is 'cleared', meaning that the PC_BEEP is unmuted on power-up.

Phone_In Volume (Index 0Ch)

D15	D14	D13	D12	D11	D10	D9	D8	D7	D6	D5	D4	D3	D2	D1	D0
Mute	X	X	X	X	X	X	X	X	X	X	GN4	GN3	GN2	GN1	GN0

This register controls the gain level of the Phone_In input source to the Output mixer. Each register step corresponds to a 1.5 dB gain adjustment allowing a range of 12 dB to -34.5 dB of gain. The MSB controls an analog mute for the Phone_In signal.

The default values for Phone_In is 8008h, corresponding to 0 dB attenuation and mute on.

Microphone Volume (Index 0Eh)

D15	D14	D13	D12	D11	D10	D9	D8	D7	D6	D5	D4	D3	D2	D1	D0
Mute	X	X	X	X	X	X	X	X	20dB	X	GN4	GN3	GN2	GN1	GN0

This register controls the gain level of the Mic_In input source to the Input Mixer. It also controls the +20 dB gain block which connects to the input volume control and to the Input Record Mux. Each register step (GN4 - GN0) corresponds to a 1.5 dB gain adjustment allowing a range of 12 dB to -34.5 dB of gain. The 20dB bit, when 'set', enables the 20 dB gain block. The MSB controls an analog mute for the Mic_In signal. The Mic_In source is selected through the General Purpose register

The default values for MIC_IN is 8008h, corresponding to 0 dB attenuation and mute on.

Stereo Analog Mixer Input Gain Registers (Index 10 - 18h)

D15	D14	D13	D12	D11	D10	D9	D8	D7	D6	D5	D4	D3	D2	D1	D0
Mute	X	X	GL4	GL3	GL2	GL1	GL0	X	X	X	GR4	GR3	GR2	GR1	GR0

These registers control the gain levels of the analog input sources to the Input Mixer. Each register step for all registers corresponds to 1.5 dB gain adjustment, thus allowing a range of 12 dB to -34.5 dB of gain. The MSB of these registers control an analog mute for each source to input mixer. Bits Gx4 - Gx0 of the registers are used to control the gain levels for each source. The gain mapping for these bits is shown in Table 3.

Gx4 - Gx0	Gain Level
00000	+12 dB
00001	+10.5 dB
...	...
00111	+1.5 dB
01000	0 dB
01001	-1.5 dB
...	...
11111	-34.5 dB

Table 3. Analog Mixer Input Gain Values

For the stereo source registers (10h through 18h), the default values are 8808h, corresponding to 0 dB attenuation for both channels, and mute on.

Input Mux Select Register (Index 1Ah)

D15	D14	D13	D12	D11	D10	D9	D8	D7	D6	D5	D4	D3	D2	D1	D0
X	X	X	X	X	SL2	SL1	SL0	X	X	X	X	X	SR2	SR1	SR0

This register selects the input source to pass to the ADCs for capturing PCM data. The AC'97 specification allows for independent control of the left and right channels for this mux. Bits SL2 - SL0 provide the decode for the left input mux, and bits SR2 - SR0 provide the decode for the right. Shown below are the possible values for each of these decodes:

Sx2 - Sx0	Record Source
0	MIC
1	CD Input
2	Video Input
3	AUX Input
4	Line Input
5	Stereo Mix
6	Mono Mix
7	Phone Input

Table 4. Input Mux Selection Options

The default power-on value for this register is 0000h, selecting the MIC inputs for both channels.

Record Gain Register (Index 1Ch)

D15	D14	D13	D12	D11	D10	D9	D8	D7	D6	D5	D4	D3	D2	D1	D0
Mute	X	X	X	GL3	GL2	GL1	GL0	X	X	X	X	GR3	GR2	GR1	GR0

This register controls the input gain on the analog source which is applied after the input mux and before the ADCs. The 4-bit value allows for 0 dB to +22.5 dB of gain in 1.5 dB steps. The most significant bit of the register controls an analog Mute which mutes the signal prior to the ADCs. The following table shows the possible gain values available:

Gx3 - Gx0	Gain
1111	+22.5 dB
0000	0 dB

Table 5. Input Mux Selection Options

The default value for this register is 8000h, which corresponds to 0 dB gain with mute on.

Record Gain Mix (Index 1Eh)

The CS4297 does not support the optional 3rd ADC for the MIC PCM input. The Record Gain Mix register has no function in The CS4297. Writes to this register are ignored, and reads from this register will always return 0000h.

General Purpose Register (Index 20h)

D15	D14	D13	D12	D11	D10	D9	D8	D7	D6	D5	D4	D3	D2	D1	D0
0	0	0	0	0	0	MIX	MS	LPBK	0	0	0	0	0	0	0

This register controls miscellaneous facets of the CS4297 mixer. The only bits which have defined functions in the CS4297 are the MIX, MS, and LPBK bits. The MIX bit selects which data to send to the Mono Output Path. A 'cleared' value enables the Mono Mix out (a mix of the 5 analog stereo sources plus PCM_OUT), while a 'set' value passes the MIC to the output. The MS (Mic Select) bit determines which of the 2 MIC inputs are passed to the rest of the mixer. A 'cleared' value selects the MIC1 input, while a 'set' value selects the MIC2 input. The LPBK bit enables ADC/DAC Loopback Mode which is used to facilitate performance evaluation of the CS4297.

Powerdown Control/Status Register (Index 26h)

D15	D14	D13	D12	D11	D10	D9	D8	D7	D6	D5	D4	D3	D2	D1	D0
0	PR6	PR5	PR4	PR3	PR2	PR1	PR0	0	0	0	0	REF	ANL	DAC	ADC

The bits in this register correspond to the AC'97 defined powerdown and status functions. See the following tables for the definitions of the individual bits which the CS4297 supports.

Bit Name	Function
REF	Vref at nominal levels
ANL	Analog Mixers, Mux, and Volume Controls ready
DAC	DAC ready to accept data
ADC	ADC ready to transmit data

Table 6. Codec Powerdown Status Bits

Bit Name	Function
PR0	ADCs and Input Mux Powerdown
PR1	DACs Powerdown
PR2	Analog Mixer Powerdown (Vref still on)
PR3	Analog Mixer Powerdown (Vref off)
PR4	AC-Link Powerdown (BIT_CLK off)
PR5	Internal Clock Disable
PR6	Alternate Line Output Buffer Powerdown

Table 7. Codec Powerdown Control Bits

Reserved Registers (Index 28h - 58h)

These registers are reserved for future use by the AC'97 specification. The CS4297 ignores writes to these registers.

Crystal Revision and Fab ID Register (Index 5Ah)

D15	D14	D13	D12	D11	D10	D9	D8	D7	D6	D5	D4	D3	D2	D1	D0
0	0	0	0	0	0	1	1	0	0	0	0	0	0	0	1

This vendor reserved register is being used by the CS4297 to indicate the revision level of the CS4297 as well as the Fab ID where the part was manufactured. This is in addition to the Vendor ID registers located below. The revision level is indicated in bits D11:8 and will be 03h for the release revision of the chip. The Fab ID is indicated in bits D3:0 and will be 01h.

Vendor Reserved Registers (Index 5C - 7Ah)

These registers are reserved for future use by the Crystal as needed. The CS4297 ignores writes to these registers, and read values from these registers will return 0000h.

Vendor ID1 (Index 7Ch)

D15	D14	D13	D12	D11	D10	D9	D8	D7	D6	D5	D4	D3	D2	D1	D0
0	1	0	0	0	0	1	0	0	1	0	1	0	0	1	0

Vendor ID2 (Index 7Eh)

D15	D14	D13	D12	D11	D10	D9	D8	D7	D6	D5	D4	D3	D2	D1	D0
0	1	0	1	1	0	0	1	0	0	0	0	0	0	1	1

The Vendor ID registers provide a means to determine the manufacturer of the AC'97 part within a system. For the CS4297, the ID registers contain the ASCII code for the first 3 letters of Crystal (CRY). The final byte of register ID2 is a Revision field for the part. In the case of the CS4297, the revision is 03h. Thus, register ID1 contains the value 4352h, and register ID2 contains 5903h.

Register #	Vendor ID Value
7Ch	4352h
7Eh	5903h

Table 8. Vendor ID Register Values

POWER MANAGEMENT

The AC'97 Specification defines a mixer register called the Powerdown Control/Status register (index 26h) for controlling power management functions within the CS4297. In the CS4297, 7 of these bits (bits 14 - 8) have defined functions. In effect, all portions of the Codec can be shut down individually and powered back up by a single Cold or Warm Reset sequence.

The following table shows the mapping of the power control bits to the functions they manage:

PR Bit	Function
PR0	Main ADC's and Input Mux Powerdown
PR1	Main DAC's Powerdown
PR2	Analog Mixer Powerdown (Vref on)
PR3	Analog Mixer Powerdown (Vref off)
PR4	AC-Link Powerdown (BIT_CLK off)
PR5	Internal Clock Disable
PR6	Alternate Line Out Buffer Powerdown

Table 9. Powerdown GPR Bit Functions

When, for example, PR0 is 'set', the main ADCs and the Input Mux are shut down and the ADC bit (bit 0 in register 26h) is 'cleared' to indicate the ADCs are no longer in a ready state. The same is true for the DACs, the Analog Mixers, and the Reference Voltage (Vrefout). When the PR bit for one of these portions of the Mixer is 'cleared', the Mixer section will begin a power-on process, and the corresponding Powerdown Status bit will be 'set' when the hardware is in a ready state.

Bit PR4, which shuts down the AC-Link, causes the AC-Link to turn off the BIT_CLK and drive SDATA_IN to a '0'. It also ignores SYNC and SDATA_OUT in their normal capacities. To restore operation to the part from this state, either a Cold or a Warm Reset is required (see Cold AC'97 Reset and Warm AC'97 Reset). A Cold Reset will restore all Mixer registers to their power-on default values. A Warm Reset will not alter the values of

any Mixer register (with the exception of 'clearing' the PR4 bit of register 26h).

Setting bit PR5 causes a global powerdown of the Codec. In this state, all internal clocks of the CS4297 are shut down. A Cold Reset is the only way to restore operation to the CS4297 in the Global Powerdown state.

One important note: The CS4297 does not automatically mute any input or output when the powerdown bits are 'set'. It is left to the software driver controlling the AC'97 device to manage muting the input and output analog signals before putting the part into any power management state.

ANALOG HARDWARE DESCRIPTION

The analog hardware consist of a four line-level stereo inputs, two selectable mono microphone inputs, two mono inputs, a mono output, and dual, independent stereo line outputs. This section describes the analog hardware needed to interface with these pins.

Line-Level Inputs

The analog inputs consist of four stereo analog inputs and four mono inputs. As shown in Figure 1, the input to the ADCs comes from the Input Mux which selects one of the following: Phone (Mono), Aux, Video, CD, Mic1 or Mic2 (Mono), Line, Stereo Output Mix, or the Mono Output Mix (Mono). Unused analog inputs should be connected together and then connected through a capacitor to analog ground or tied to the Vrefout line directly.

The analog input mixer is designed to accommodate five stereo inputs and one mono input. These inputs are: a stereo line-level input (LINE), a mono microphone input (MIC), a stereo CD-ROM input (CD), a stereo auxiliary line-level input (AUX), and the PCM output from the DACs. Each of the stereo inputs has separate volume controls for each channel and one mute control for each left/right pair. The mono microphone input has one mute and one volume control.

The inputs to the output mixer are: the input mixer output, the PC Beep mono input, and the Phone mono input.

All analog inputs to the CS4297, including CD_GND, should be capacitively coupled to the input pins.

Since many analog levels can be as large as $2 V_{RMS}$, the circuit shown in Figure 4 can be used to attenuate the analog input by 6 dB (to $1 V_{RMS}$) which is the maximum voltage allowed for all the stereo line-level inputs: LINE_IN, AUX_IN, and VIDEO_IN.

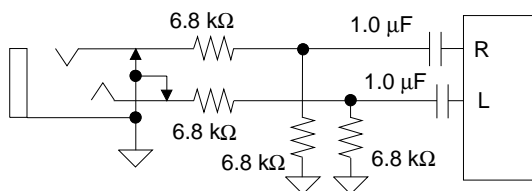

Figure 4. Line Inputs

The CD line-level inputs have an extra pin, CD_GND, which provides a pseudo-differential input for both CD_L and CD_R. This pin takes the common-mode noise out of the CD inputs when connected to the ground coming from the CD analog source. Connecting the CD pins as shown in Figure 5 provides extra attenuation of common mode noise coming from the CDROM drive, thereby producing a higher quality signal. One percent resistors are recommended since the better the resistors match, the better the common-mode attenuation of unwanted signals. If CD is not used, the inputs should be connected through AC capacitors to analog ground or connected to Vrefout.

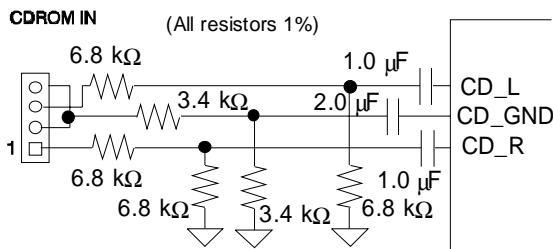

Figure 5. Differential CDROM In

Microphone Level Inputs

The microphone level inputs, MIC1 and MIC2, include a selectable -34.5 dB to +12 dB gain stage for interfacing to an external microphone. An additional 20 dB gain block is also available. Figure 6 illustrates a single-ended microphone input buffer circuit that will support lower gain mics. The circuit in Figure 6 supports dynamic mics and phantom-powered mics that use the right channel (ring) of the jack for power.

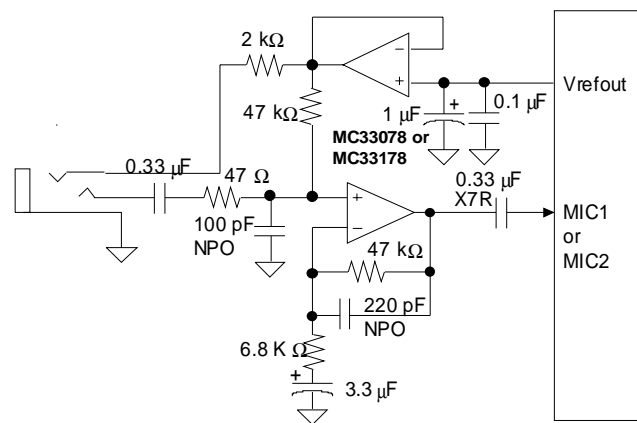

Figure 6. Microphone Input

Mono Inputs

The mono input, PC_BEEP, is useful for mixing the output of the “beeper” (timer chip), provided in all PCs, with the rest of the audio signals. The attenuation control allows 16 levels in -3 dB steps. In addition, a mute control is provided. The attenuator is a single channel block with the resulting signal sent to the output mixer where it is mixed with the left and right outputs. Figure 7 illustrates a typical input circuit for the PC_BEEP input. If PC_BEEP is driven from a CMOS gate, the 4.7 kΩ should be tied to AGND instead of VA+. Although this input is described for a low-quality beeper, the input is of the same high-quality as all other analog inputs and may be used for other purposes.

The mono input, PHONE_IN, can be used to interface to the output of a MODEM Analog Front End

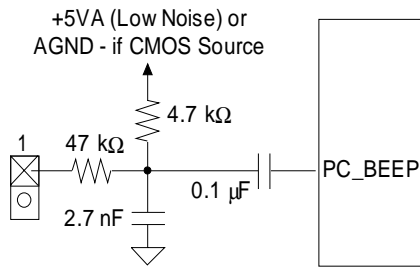

Figure 7. Mono Input

(AFE) chip so that Modem dialing signals and protocol negotiations may be monitored through the audio system. Like all other analog inputs, this pin must be AC coupled and the input signal must be limited to 1 V_{RMS}.

Line Level Outputs

The analog output section provides a stereo line-level output and an alternate stereo line-level output. LINE_OUT_L, LINE_OUT_R, ALT_LINE_OUT_L, and ALT_LINE_OUT_R outputs should be capacitively coupled to external circuitry.

The mono output, MONO_OUT, can be used as either a sum of the left and right output channels attenuated by 6 dB to prevent clipping at full scale or the selected MIC_IN signal. The mono out channel can be used to drive the PC internal mono speaker using an appropriate drive circuit. This approach allows the traditional PC sounds to be integrated with the rest of the audio system. The mute control is independent of the line outputs allowing the mono channel to mute the speaker without muting the line outputs.

Each of the 5 analog outputs, if used in the design, require 680 pF or larger NPO dielectric capacitors between the corresponding pin and AGND. Each analog output is DC biased up to the Vrefout voltage signal reference which is nominally 2.2 V. This requires that the output either be AC coupled to external circuitry (AC load must be greater than 10 kΩ) or DC coupled to a buffer op-amp biased at the Vrefout voltage (see Figure 8 for the recommended headphone op-amp circuit).

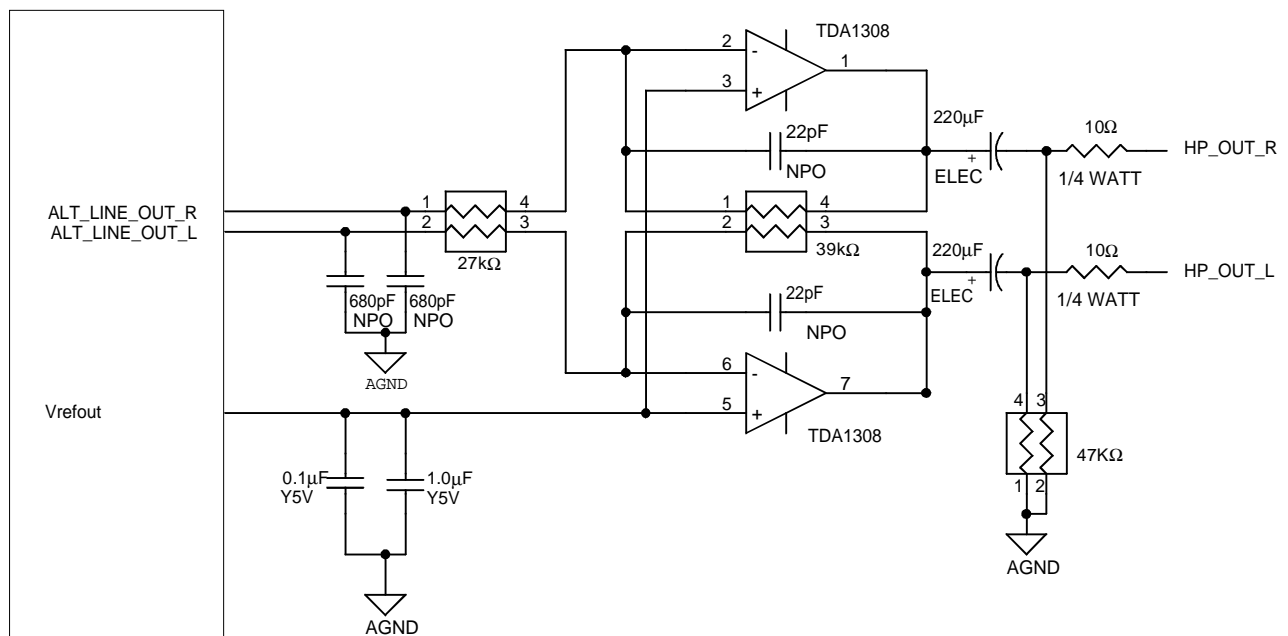

Figure 8. Headphones Driver

Miscellaneous Analog Signals

The AFILT1 and AFILT2 pins must have a 390 pF NPO capacitor (must not be smaller than 390 pF) to analog ground. These capacitors, along with an internal resistor, provide a single-pole low-pass filter at the inputs to the ADCs. By placing these filters at the input to the ADCs, low-pass filters at each analog input pin are not necessary.

The REFFLT pin lowers the noise of the internal voltage reference. A 1 μ F (must not be greater than 1 μ F) and 0.1 μ F capacitor to analog ground should be connected with a short, wide trace to this pin (see Figure 10 in the *Grounding and Layout* section for an example). No other connection should be made, as any coupling onto this pin will degrade the analog performance of the Codec. Likewise, digital signals should be kept away from REFFLT for similar reasons.

The Vrefout pin is typically 2.2 V and provides a common mode signal for single-supply external circuits. Vrefout only supports light DC loads and should be buffered if AC loading is needed. For typical use, a 0.1 μ F in parallel with a 1 μ F capacitor should be connected to Vrefout.

Power Supplies

The power supplies providing analog power should be as clean as possible to minimize coupling into

the analog section which could degrade analog performance. The pins AVdd1 and AVdd2 supply power to all the analog circuitry on the CS4297. This 5 Volt analog supply should be generated from a voltage regulator (7805 type) connected to a +12 Volt supply. This helps isolate the analog circuitry from noise typically found on +5 V digital supplies which power many digital circuits in a PC environment. A typical voltage regulator circuit for analog power using an MC78M05CDT is shown in Figure 9.

The digital power pins DVdd1 and DVdd2 should be connected to the same digital supply as the AC'97 Controller's AC-Link interface. Since the digital interface on the CS4297 may operate at either 3.3 V or 5 V, proper connection of these pins will depend on the digital power supply of the AC'97 Controller.

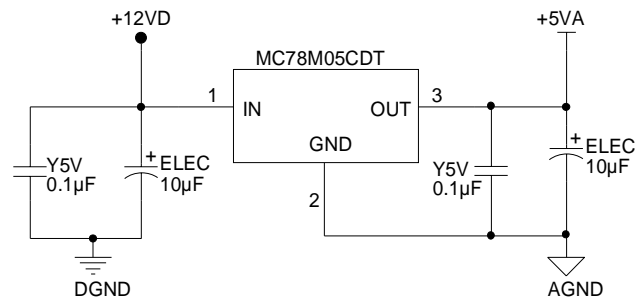

Figure 9. Voltage Regulator

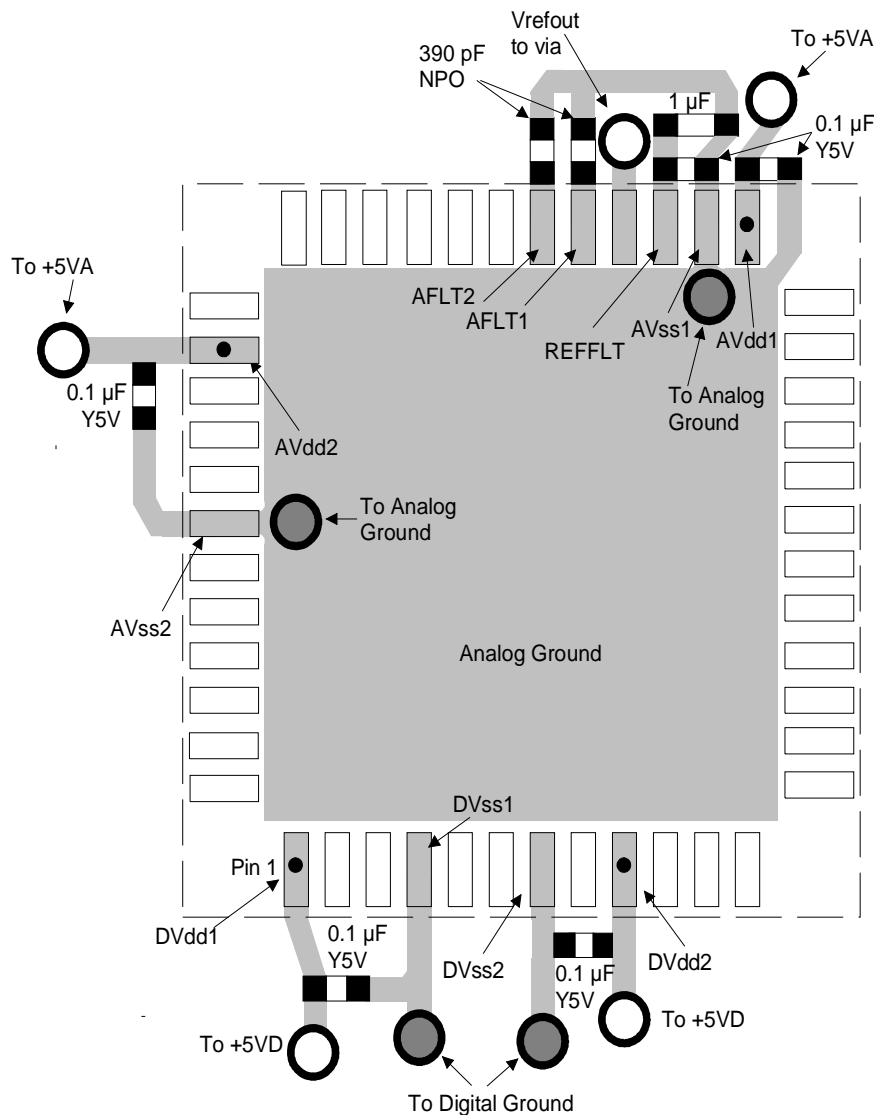

Figure 10. Suggested Layout for the CS4297

GROUNDING AND LAYOUT

Figure 10 is the suggested layout for the CS4297. The decoupling capacitors should be located physically as close to the pins as possible. Also note the routing of the REFFLT decoupling capacitors and the isolation of that ground strip.

It is strongly recommended that the device be located on a locally separate analog ground plane. This analog ground plane is used to keep noise from digital ground return currents from modulating the CS4297's ground potential and degrading performance. The digital ground pins should be connect-

ed to the digital ground plane and kept separate from the analog ground connections of the CS4297 and any other external analog circuitry.

It is also recommended that the common connection point between the two ground planes (required to maintain a common ground voltage potential) be located near the CS4297 just under the digital ground connections (vias). The AC-Link digital interface connection traces should be routed such that digital ground plane lies underneath these signals (on the internal ground layer) from the AC'97 Controller continuously to the CS4297.

PERFORMANCE PLOTS

Figures 11 through 26 show the overall Frequency Response, the THD+N over frequency, and the DR over frequency of the ADCs, the DACs, the analog mixer (Line In to Line Out) and the microphone inputs. Crosstalk plots and the noise floor FFT plots of the DACs, the analog mixer and the muted noise floor of the CS4297 are also included. All plots were taken on a CRD4297-1 with a CS4297-KQ Codec.

Figures 11, 14, 17, and 20: The Frequency Response plots were taken using a -20 dB FS input signal swept over the frequency range of 20 Hz to 20 kHz and normalized to 0 dB at 1 kHz.

Figures 12, 15, 18, and 21: The THD+N plots were taken using a -3 dB FS input signal swept over the frequency range of 20 Hz to 20 kHz. These performance plots used an “A”-weighted filter applied on the output with the exception of the ADC THD+N plot.

Figures 13, 16, 19, and 22: The Dynamic Range plots were taken using a -50 dB FS input signal swept over the frequency range of 20 Hz to 20 kHz. These performance plots used an “A”-weighted filter applied on the output with the exception of the ADC Dynamic Range plot.

Figure 23: The crosstalk plot was generated using a 0 dB FS input signal on one channel of the LINE_IN input and measuring the magnitude of the other output channel swept over the frequency

range of 20 Hz to 20 kHz. This performance plots used an “A”-weighted filter applied on the output

Figures 24, 25, and 26: The noise floor plots were generated by running a 16K-point FFT on the LINE_OUT output with no input signal applied. The Muted Noise Floor plot was taken with the master mute bit ‘set’ (bit D15, register 0x02h). These performance plots used an “A”-weighted filter applied on the output

All audio performance plots used unity gain settings on the analog volume controls. Additionally, the microphone input plots were taken with the +20 dB gain stage enabled (bit D6, register 0x0Eh).

The ADC plots used the A-D signal path. The DAC plots used the D-A signal path. The mixer and the microphone plots used the A-A signal path.

Schematic & Layout Review Service

Confirm Optimum
Schematic & Layout
Before Building Your Board.

For Our Free Review Service
Call Applications Engineering.



C a l l : (5 1 2) 4 4 5 - 7 2 2 2

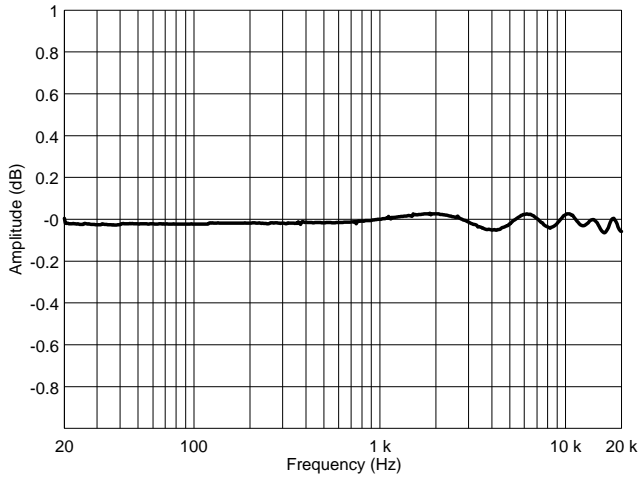

Figure 11. ADC Frequency Response

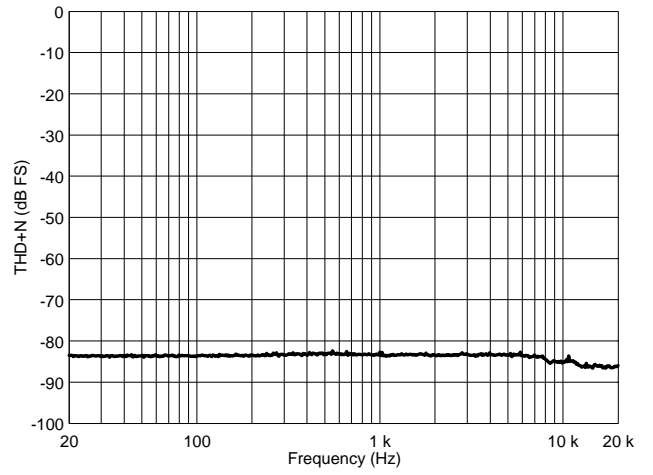

Figure 12. ADC THD+N vs. Frequency

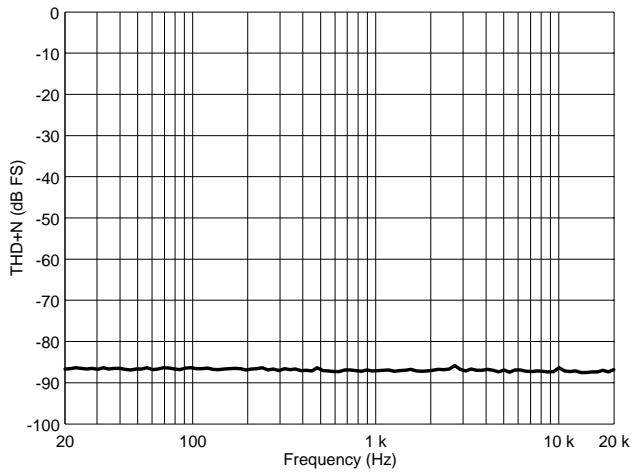

Figure 13. ADC DR vs. Frequency

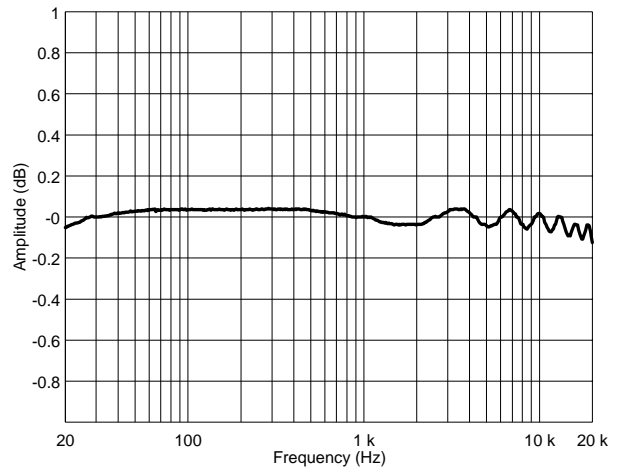

Figure 14. DAC Frequency Response

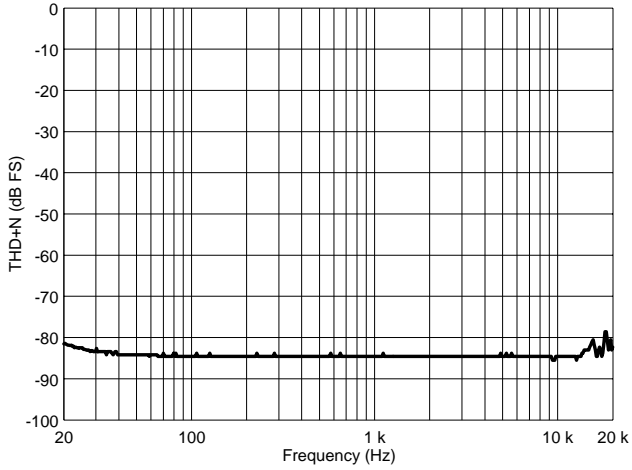

Figure 15. DAC THD+N vs. Frequency

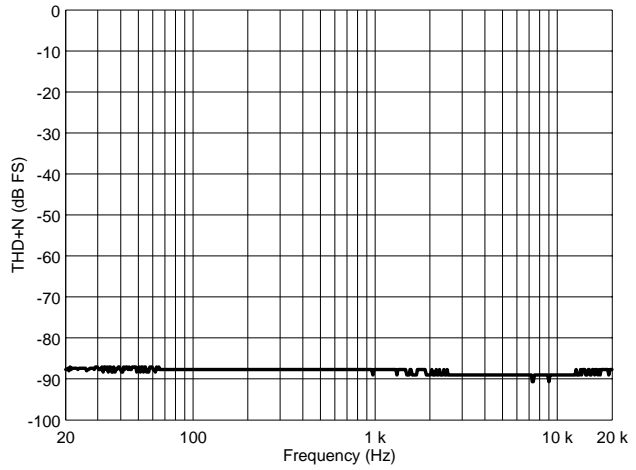

Figure 16. DAC DR vs. Frequency

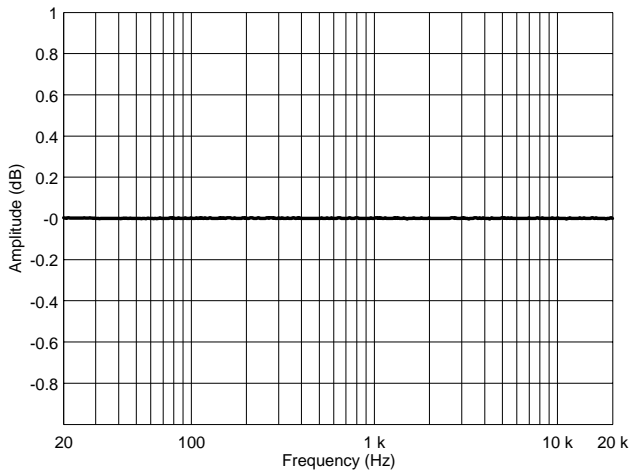

Figure 17. Mixer Frequency Response

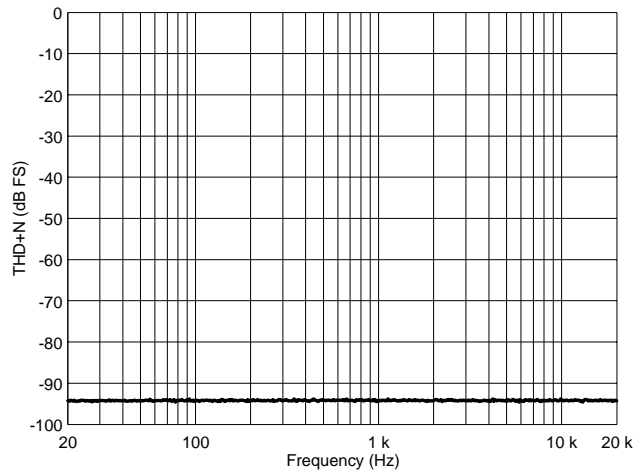

Figure 18. Mixer THD+N vs. Frequency

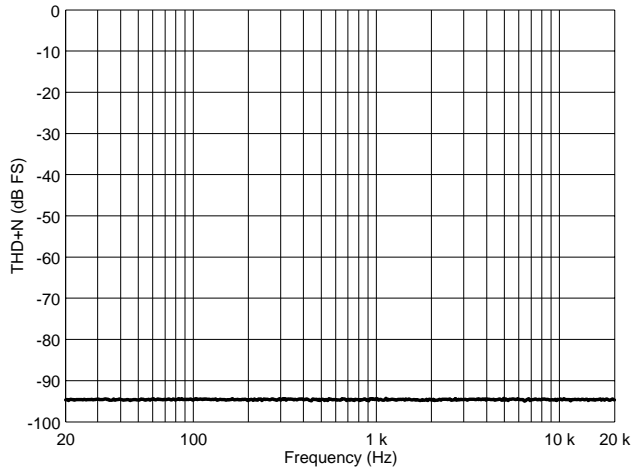

Figure 19. Mixer DR vs. Frequency

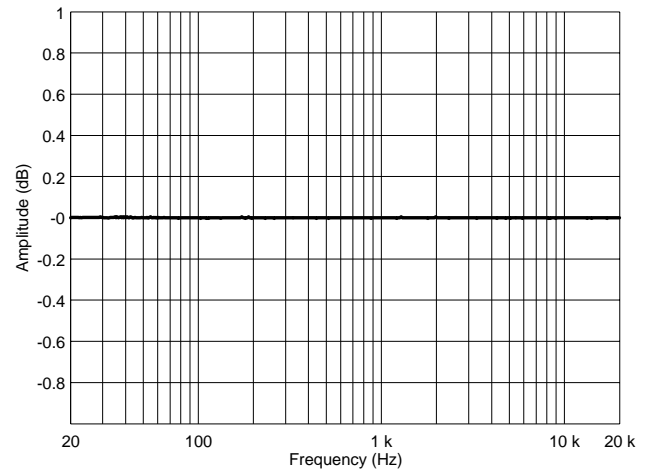

Figure 20. Microphone Frequency Response

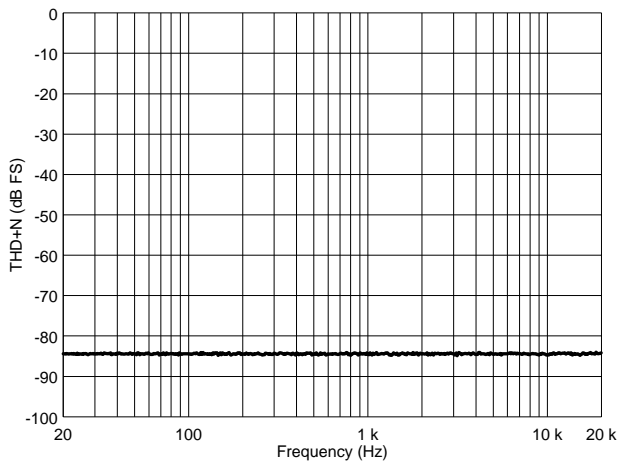

Figure 21. Microphone THD+N vs. Frequency

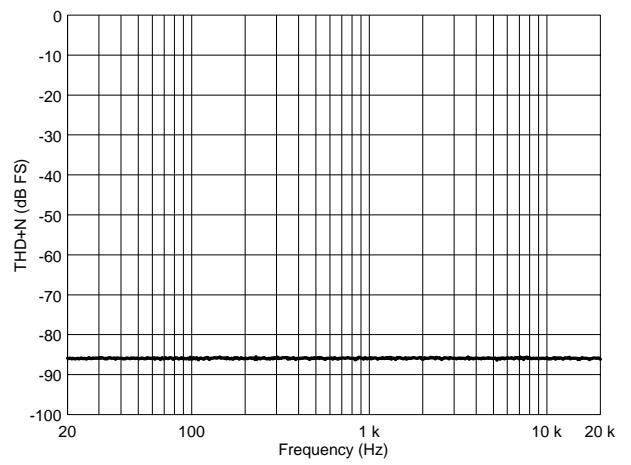

Figure 22. Microphone DR vs. Frequency

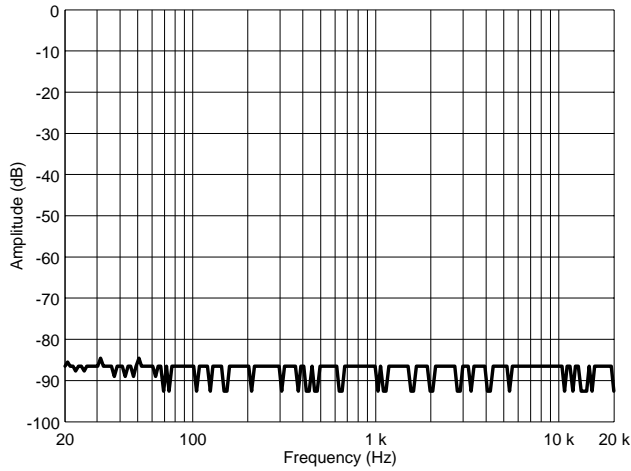

Figure 23. Mixer Crosstalk vs. Frequency

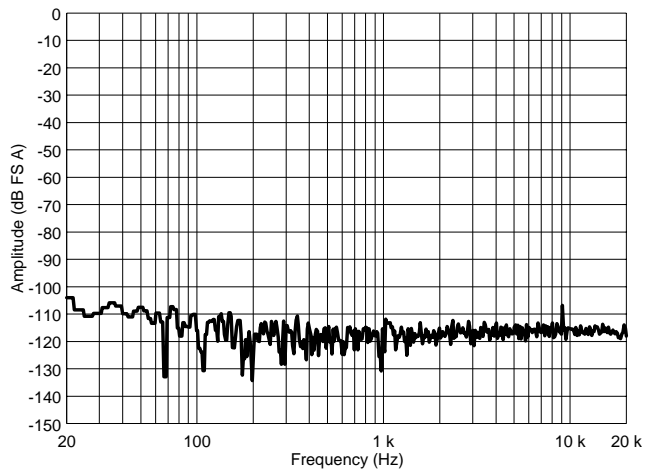

Figure 24. DAC Noise Floor FFT

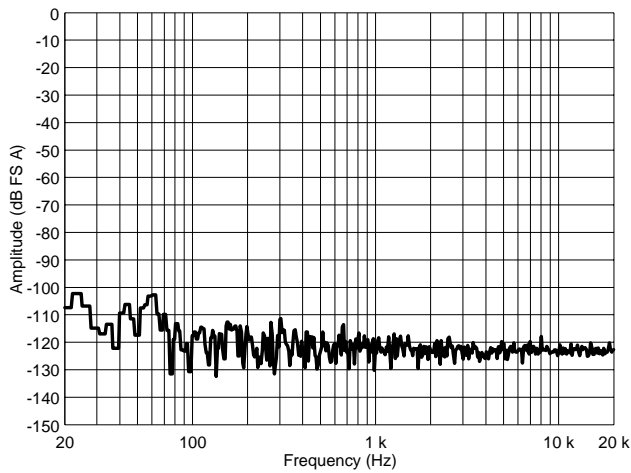

Figure 25. Mixer Noise Floor FFT

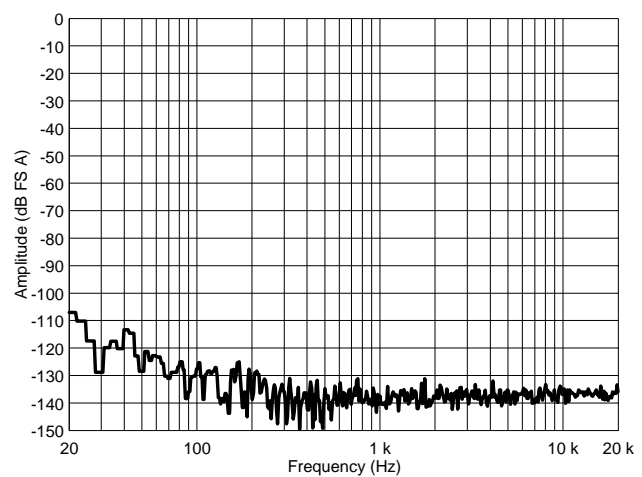
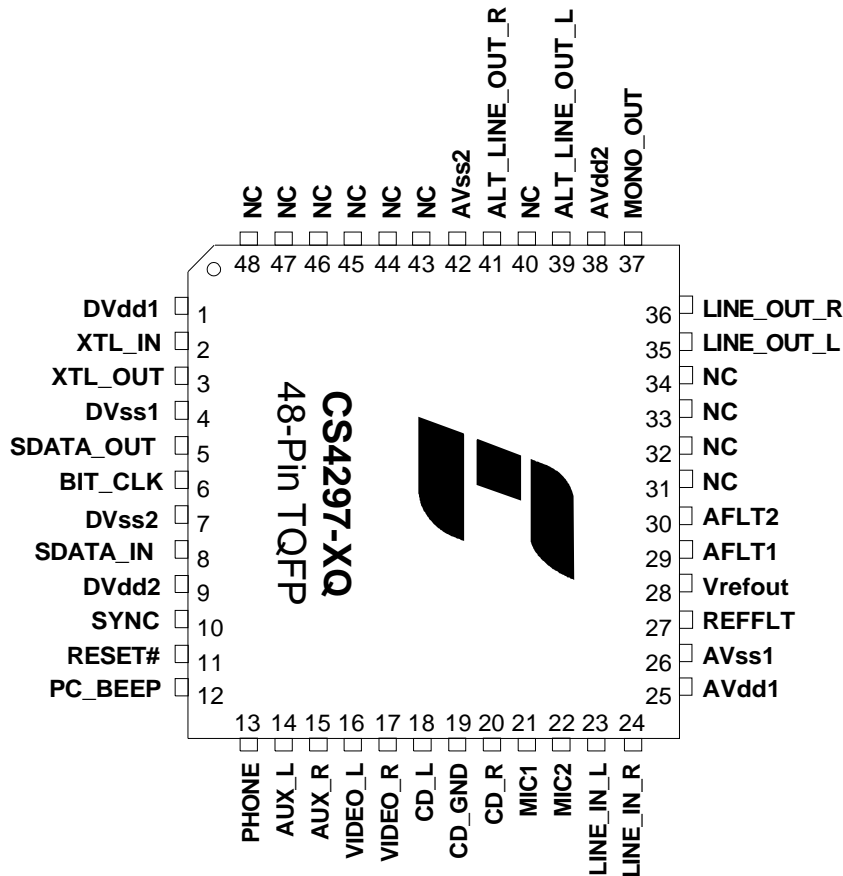

Figure 26. Muted Noise Floor FFT

PIN DESCRIPTIONS



Digital I/O Pins

RESET# - AC'97 Chip Reset, Input

This active low signal is the asynchronous Cold Reset input to the CS4297. The CS4297 must be reset before it can enter normal operating mode.

SYNC - AC-link Serial Port Sync pulse, Input

This signal is the serial port timing signal for the AC-link of the CS4297. Its period is the reciprocal of the sample rate of the CS4297, 48 kHz. This signal is generated by the AC'97 Controller and is synchronous to BIT_CLK. SYNC is also an asynchronous input when the CS4297 is in a Warm Reset state. A series terminating resistor of 47 Ω should be connected on this signal close to the device driving the signal.

BIT_CLK - AC-link Serial Port Master Clock, Output

This output signal controls the master clock timing for the AC-link. It is a 12.288 MHz clock signal which is divided down by two from the XTL_IN input clock. A series terminating resistor of 47 Ω should be connected on this signal close to the CS4297.

SDATA_OUT - AC-link Serial Data Input Stream to AC'97, Input

This input signal transmits the control information and digital audio output streams to be sent to the DACs. The data is clocked into the CS4297 on the falling edge of BIT_CLK. A series terminating resistor of 47 Ω should be connected on this signal close to the device driving the input.

SDATA_IN - AC-link Serial Data Output Stream from AC'97, Output

This output signal transmits the status information and digital audio input streams from the ADCs. The data is clocked out of the CS4297 on the rising edge of BIT_CLK. (See the *Digital Hardware Description* section). A series terminating resistor of 47 Ω should be connected on this signal as close to the CS4297 as possible.

XTL_IN - Crystal Input

This pin accepts either a crystal, with the other pin attached to XTL_OUT, or an external CMOS clock. XTL_IN must have a crystal or clock source attached for proper operation. The crystal frequency must be 24.576 MHz and designed for fundamental mode, parallel resonance operation.

XTL_OUT - Crystal Output

This pin is used for a crystal placed between this pin and XTL_IN. If an external clock is used on XTL_IN, this pin must be left floating with no traces or components connected to it.

Analog I/O Pins**PC_BEEP - Analog Mono Source, Input**

This signal is intended to be used as an internal PC BEEP connection to the audio subsystem. This source is NOT input to the Stereo-to-Mono mixer. The maximum allowable input is 1 V_{RMS} (sinusoidal). This input is internally biased at the Vrefout voltage reference and requires AC coupling to external circuitry. If this input is not used, it should be connected to the Vrefout pin or AC coupled to Analog ground.

PHONE - Analog Mono Source, Input

This signal is intended to be used as a Voice Modem connection to the audio subsystem. This source is NOT input to the Stereo-to-Mono mixer. The maximum allowable input is 1 V_{RMS} (sinusoidal). This input is internally biased at the Vrefout voltage reference and requires AC coupling to external circuitry. If this input is not used, it should be connected to the Vrefout pin or AC coupled to Analog ground.

MIC1 - Analog Mono Source, Input

This analog input is monophonic source to the analog output mixer. It is intended to be used as a desktop microphone connection to the audio subsystem. This input is MUX selectable to the input mixer with the MIC2 input source. The maximum allowable input is 1 V_{RMS} (sinusoidal). This input is internally biased at the Vrefout voltage reference and requires AC coupling to external circuitry. If this input is not used, it should be AC coupled to Analog ground.

MIC2 - Analog Mono Source, Input

This analog input is a monophonic source to the analog output mixer. It is intended to be used as an alternate microphone connection to the audio subsystem. This input is MUX selectable to the input mixer with the MIC1 input source. The maximum allowable input is $1 V_{RMS}$ (sinusoidal). This input is internally biased at the Vrefout voltage reference and requires AC coupling to external circuitry. If this input is not used, it should be AC coupled to Analog ground.

LINE_IN_L and LINE_IN_R- Analog Line Source, Inputs

These inputs form a stereo input pair to the CS4297. The maximum allowable input is $1 V_{RMS}$ (sinusoidal). These inputs are internally biased at the Vrefout voltage reference. AC coupling to external circuitry is required. If these inputs are not used, they should both be connected to the Vrefout pin or both AC coupled, with separate AC coupling caps, to Analog ground.

CD_L and CD_R - Analog CD Source, Inputs

These inputs form a stereo input pair to the CS4297. It is intended to be used for the Redbook CD audio connection to the audio subsystem. The maximum allowable input is $1 V_{RMS}$ (sinusoidal). These inputs are internally biased at the Vrefout voltage reference. AC coupling to external circuitry is required. If these inputs are not used, they should both be connected to the Vrefout pin or both AC coupled, with separate AC coupling caps, to Analog ground.

CD_GND - Analog CD Common Source, Input

This analog input is used to remove common mode noise from Redbook CD audio signals. The impedance on the input signal path should be one half the impedance on the CD_L and CD_R input paths. This pin requires AC coupling to external circuitry. If this input is not used, it should be connected to the Vrefout pin or AC coupled to Analog ground.

VIDEO_L and VIDEO_R - Analog Video Audio Source, Inputs

These inputs form a stereo input pair to the CS4297. It is intended to be used for the audio signal output of a video device. The maximum allowable input is $1 V_{RMS}$ (sinusoidal). These inputs are internally biased at the Vrefout voltage reference. AC coupling to external circuitry is required. If these inputs are not used, they should both be connected to the Vrefout pin or both AC coupled, with separate AC coupling caps, to Analog ground.

AUX_L and AUX_R - Analog Auxiliary Source, Inputs

These inputs form a stereo input pair to the CS4297. The maximum allowable input is $1 V_{RMS}$ (sinusoidal). These inputs are internally biased at the Vrefout voltage reference. AC coupling to external circuitry is required. If these inputs are not used, they should both be connected to the Vrefout pin or both AC coupled, with separate AC coupling caps, to Analog ground.

LINE_OUT_L and LINE_OUT_R - Analog Line Level Outputs

These signals are analog outputs from the stereo output mixer. The full scale output voltage for output is nominally $1 V_{RMS}$ and is internally biased at the Vrefout voltage reference. It is required to either AC couple these pins to external circuitry or DC couple them to a buffer op-amp biased at the Vrefout voltage. These pins need a 680 pF NPO capacitor attached to analog ground.

ALT_LINE_OUT_L and ALT_LINE_OUT_R - Analog Alternate Line Level Outputs

These signals are analog outputs from the stereo output mixer. The full scale output voltage for each output is nominally $1 V_{RMS}$ and is internally biased at the Vrefout voltage reference. It is required to either AC couple these pins to external circuitry or DC couple them to a buffer op-amp biased at the Vrefout voltage. These pins need a 680 pF NPO capacitor attached to analog ground.

MONO_OUT, Analog Mono Line Level Output

This signal is an analog output from the Mono output mixer. This is a left and right channel mix of the output of the stereo input mixer. The full scale output is nominally $1 V_{RMS}$ and is internally biased at the Vrefout voltage reference. AC coupling to external circuitry is required. This pin needs a 680 pF NPO capacitor attached to analog ground.

*Filter and Reference Pins***REFFLT - Internal Reference Voltage, Input**

This is the voltage reference used internal to the part. A 0.1 μF and a 1 μF (must not be larger than 1 μF) capacitor with short, wide traces must be connected to this pin. No other connections should be made to this pin.

Vrefout - Voltage Reference, Output

All analog inputs and outputs are centered around Vrefout which is nominally 2.2 Volts. This pin may be used to level shift external circuitry, however any external loading should be buffered.

AFLT1 - Left Channel Antialiasing Filter Input

This pin needs a 390 pF NPO capacitor attached to analog ground.

AFLT2 - Right Channel Antialiasing Filter Input

This pin needs a 390 pF NPO capacitor attached to analog ground.

Power Supplies

DVdd1, DVdd2 - Digital Supply Voltage

These pins provide the digital supply voltage for the AC-link section of the CS4297. These pins may be tied to +5 V digital or to +3.3 V digital. The CS4297 and digital controller's AC-link should share a common digital supply

DVss1, DVss2 - Digital Ground

These pins are the digital ground connection for the AC-link section of the CS4297. These pins should be isolated from analog ground currents.

AVdd1, AVdd2 - Analog Supply Voltage

These pins provide the analog supply voltage for the analog and mixed signal sections of the CS4297. These pins must be tied to +5 Volt power supply. It is strongly recommended that +5 Volts be generated from a voltage regulator to ensure proper supply currents and noise immunity from the rest of the system.

AVss1, AVss2 - Analog Ground

These pins are the ground connection for the analog, mixed signal, and substrate sections of the CS4297. These pins should be isolated from digital ground currents.

REFERENCES

- 1) Intel, Audio Codec '97 Component Specification, Revision 1.03, September 15, 1996.
<http://developer.intel.com/pc-supp/platform/ac97/>
- 2) Cirrus Logic, CS4610 SoundFusion PCI Audio Accelerator Data Sheet.
<http://www.corp.cirrus.com/products/overviews/cs4610.html>
- 3) Cirrus Logic, CRD4610-1 AC'97 Motherboard Reference Design Data Sheet.
<http://www.cirrus.com/ftp/pubs/4610rd1.pdf>
- 4) Steve Harris, Clif Sanchez, Personal Computer Audio Quality Measurements, Ver 0.5
<http://www.corp.cirrus.com/products/papers/meas/meas.html>
- 5) Microsoft, PC Design Guidelines,
<http://www.microsoft.com/hwdev/desguid/>

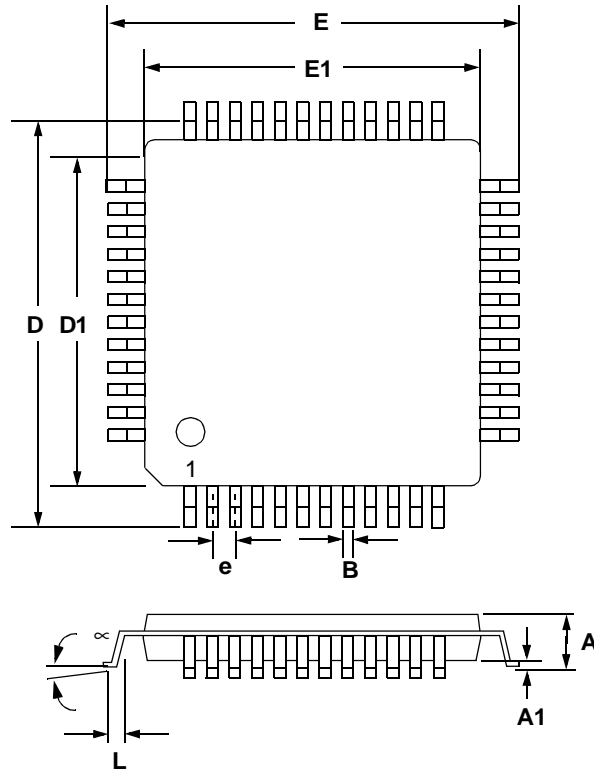
PACKAGE DIMENSIONS
48L TQFP PACKAGE DRAWING

DIM	INCHES		MILLIMETERS	
	MIN	MAX	MIN	MAX
A	----	0.063	----	1.600
A1	0.002	0.006	0.050	0.150
B	0.007	0.011	0.170	0.270
D	0.343	0.366	8.700	9.300
D1	0.272	0.280	6.900	7.100
E	0.343	0.366	8.700	9.300
E1	0.272	0.280	6.900	7.100
e*	0.016	0.024	0.400	0.600
L	0.018	0.030	0.450	0.750
∞	0.000°	7.000°	0.000°	7.000°

* Nominal pin pitch is 0.50 mm

Controlling dimension is mm.

JEDEC Designation: MS026

• **Notes** •

SMART
Analog™

This datasheet has been downloaded from:

www.DatasheetCatalog.com

Datasheets for electronic components.



LittleDiode supplies new, hard to find or obsolete electronic components and semiconductors all over the world.

With over two million different components listed you are sure to find the part you need.

Feel free to visit us today at our online store:

LittleDiode.com

Looking forward to providing you with the best possible service.