

## CrystalClear® SoundFusion™ Audio Codec '97

### Features

- AC '97 2.1 Compatible
- Industry Leading Mixed Signal Technology
- 20-bit Stereo Digital-to-Analog Converters
- 18-bit Stereo Analog-to-Digital Converters
- Sample Rate Converters
- Four Analog Line-level Stereo Inputs for LINE\_IN, CD, VIDEO, and AUX
- Two Analog Line-level Mono Inputs for Modem and Internal PC BEEP
- Dual Stereo Line-level Outputs for LINE\_OUT and ALT\_LINE\_OUT
- Dual Microphone Inputs
- High Quality Pseudo-Differential CD Input
- Extensive Power Management Support

- Meets or Exceeds the Microsoft® PC 99 Audio Performance Requirements
- S/PDIF Digital Audio Output
- CrystalClear® 3D Stereo Enhancement

### Description

The CS4299 is an AC '97 2.1 compatible stereo audio codec designed for PC multimedia systems. Using the industry leading CrystalClear® delta-sigma and mixed signal technology, the CS4299 enables the design of PC 99-compliant desktop, portable, and entertainment PCs.

Coupling the CS4299 with a PCI audio accelerator or core logic supporting the AC '97 interface, implements a cost effective, superior quality, audio solution. The CS4299 surpasses PC 99 and AC '97 2.1 audio quality standards.

### ORDERING INFO

CS4299-KQ	48-pin TQFP	9x9x1.4 mm
CS4299-JQ	48-pin TQFP	9x9x1.4 mm

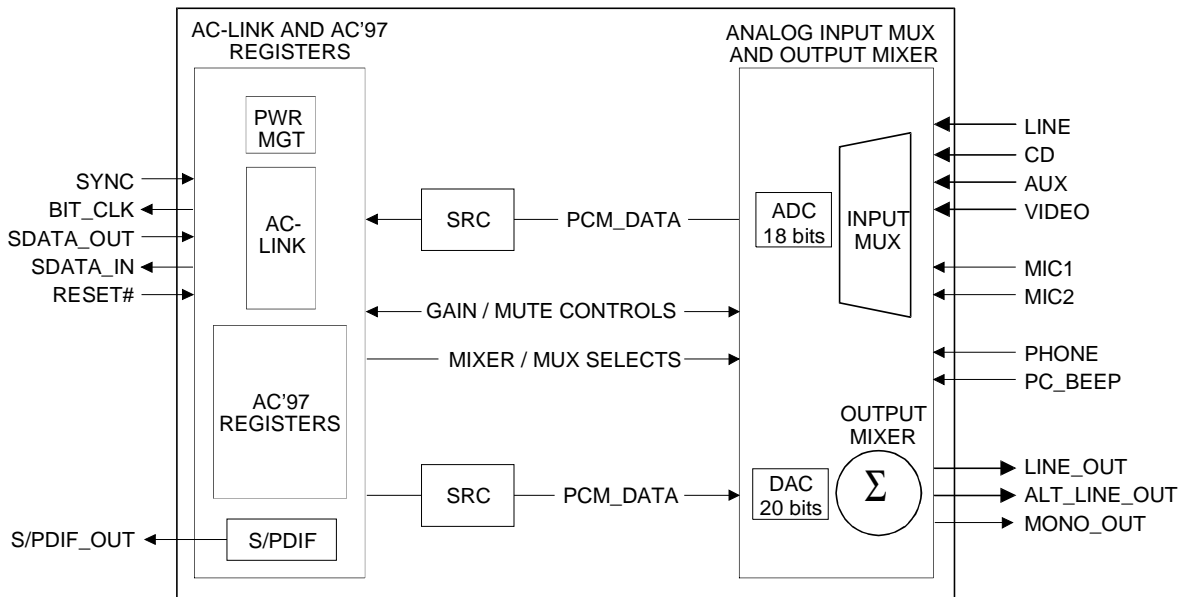

### Preliminary Product Information

This document contains information for a new product. Cirrus Logic reserves the right to modify this product without notice.

---

**TABLE OF CONTENTS**

<b>1. CHARACTERISTICS AND SPECIFICATIONS .....</b>	<b>5</b>
Analog Characteristics .....	5
Mixer Characteristics .....	6
Absolute Maximum Ratings .....	6
Recommended Operating Conditions .....	6
Digital Characteristics .....	6
AC '97 Serial Port Timing.....	7
<b>2. GENERAL DESCRIPTION .....</b>	<b>10</b>
2.1 AC-Link .....	10
2.2 Control registers .....	10
2.3 Sample Rate Converters .....	11
2.4 Output Mixer .....	11
2.5 Input Mux .....	11
2.6 Volume Control .....	11
<b>3. AC LINK FRAME DEFINITION .....</b>	<b>13</b>
3.1 AC-Link Serial Data Output Frame .....	14
3.1.1 Serial Data Output Slot Tags (Slot 0) .....	14
3.1.2 Command Address Port (Slot 1) .....	15
3.1.3 Command Data Port (Slot 2) .....	15
3.1.4 PCM Playback Data (Slots 3-10) .....	15
3.2 AC-Link Audio Input Frame .....	16
3.2.1 Serial Data Input Slot Tag Bits (Slot 0) .....	16
3.2.2 Status Address Port (Slot 1) .....	16
3.2.3 Status Data Port (Slot 2) .....	17
3.2.4 PCM Capture Data (Slot 3-10) .....	17
3.3 AC-Link Protocol Violation - Loss of SYNC .....	18
<b>4. REGISTER INTERFACE .....</b>	<b>19</b>
4.3 Reset Register (Index 00h) .....	20
4.4 Master Volume Register (Index 02h) .....	20
4.5 Alternate Volume Register (Index 04h) .....	21
4.6 Mono Volume Register (Index 06h) .....	21
4.7 PC_BEEP Volume Register (Index 0Ah) .....	22
4.8 Phone Volume Register (Index 0Ch) .....	22

---

**Contacting Cirrus Logic Support**

For a complete listing of Direct Sales, Distributor, and Sales Representative contacts, visit the Cirrus Logic web site at:  
<http://www.cirrus.com/corporate/contacts/sales.cfm>

---

Microsoft is a registered trademark of Microsoft Corporation in the United States and/or other countries.

Intel is a registered trademark of Intel Corporation.

Crystal Clear and Sound Fusion are trademarks of Cirrus Logic.

Preliminary product information describes products which are in production, but for which full characterization data is not yet available. Advance product information describes products which are in development and subject to development changes. Cirrus Logic, Inc. has made best efforts to ensure that the information contained in this document is accurate and reliable. However, the information is subject to change without notice and is provided "AS IS" without warranty of any kind (express or implied). No responsibility is assumed by Cirrus Logic, Inc. for the use of this information, nor for infringements of patents or other rights of third parties. This document is the property of Cirrus Logic, Inc. and implies no license under patents, copyrights, trademarks, or trade secrets. No part of this publication may be copied, reproduced, stored in a retrieval system, or transmitted, in any form or by any means (electronic, mechanical, photographic, or otherwise) without the prior written consent of Cirrus Logic, Inc. Items from any Cirrus Logic website or disk may be printed for use by the user. However, no part of the printout or electronic files may be copied, reproduced, stored in a retrieval system, or transmitted, in any form or by any means (electronic, mechanical, photographic, or otherwise) without the prior written consent of Cirrus Logic, Inc. Furthermore, no part of this publication may be used as a basis for manufacture or sale of any items without the prior written consent of Cirrus Logic, Inc. The names of products of Cirrus Logic, Inc. or other vendors and suppliers appearing in this document may be trademarks or service marks of their respective owners which may be registered in some jurisdictions. A list of Cirrus Logic, Inc. trademarks and service marks can be found at <http://www.cirrus.com>.

4.9	Microphone Volume Register (Index 0Eh) .....	23
4.10	Stereo Analog Mixer Input Gain Registers (Index 10h - 18h) .....	24
4.11	Input Mux Select Register (Index 1Ah) .....	25
4.12	Record Gain Register (Index 1Ch) .....	25
4.13	General Purpose Register (Index 20h) .....	26
4.14	3D Control Register (Index 22h) .....	26
4.15	Powerdown Control/Status Register (Index 26h) .....	27
4.16	Extended Audio ID Register (Index 28h) .....	28
4.17	Extended Audio Status/Control Register (Index 2Ah) .....	28
4.18	PCM Front DAC Rate Register (Index 2Ch) .....	29
4.19	PCM L/R ADC Rate Register (Index 32h) .....	29
4.20	AC Mode Control Register (Index 5Eh) .....	30
4.21	Misc. Crystal Control Register (Index 60h) .....	30
4.22	S/PDIF Control Register (Index 68h) .....	31
4.23	Vendor ID1 Register (Index 7Ch) .....	32
4.24	Vendor ID2 Register (Index 7Eh) .....	32
<b>5.</b>	<b>POWER MANAGEMENT .....</b>	<b>33</b>
5.1	AC '97 Reset Modes .....	33
5.1.1	Cold AC '97 Reset .....	33
5.1.2	Warm AC '97 Reset .....	33
5.1.3	Register AC '97 Reset .....	33
5.2	Powerdown Controls .....	34
<b>6.</b>	<b>ANALOG HARDWARE DESCRIPTION .....</b>	<b>36</b>
6.1	Analog Inputs .....	36
6.1.1	Line-Level Inputs .....	36
6.1.2	CD Input .....	36
6.1.3	Microphone Inputs .....	37
6.1.4	PC Beep Input .....	37
6.1.5	Phone Input .....	38
6.2	Analog Outputs .....	38
6.2.1	Stereo Outputs .....	38
6.2.2	Mono Output .....	38
6.3	Miscellaneous Analog Signals .....	39
6.4	Power Supplies .....	39
6.5	Reference Design .....	39
<b>7.</b>	<b>SONY/PHILIPS DIGITAL INTERFACE (S/PDIF) .....</b>	<b>40</b>
<b>8.</b>	<b>GROUNDING AND LAYOUT .....</b>	<b>40</b>
<b>9.</b>	<b>PIN DESCRIPTIONS .....</b>	<b>42</b>
<b>10.</b>	<b>PARAMETER AND TERM DEFINITIONS .....</b>	<b>47</b>
<b>11.</b>	<b>REFERENCE DESIGN .....</b>	<b>49</b>
<b>12.</b>	<b>REFERENCES .....</b>	<b>50</b>
<b>13.</b>	<b>PACKAGE DIMENSIONS .....</b>	<b>51</b>

## LIST OF FIGURES

Figure 1.	Power Up Timing .....	8
Figure 2.	Codec Ready from Startup or Fault Condition .....	8
Figure 3.	Clocks .....	8
Figure 4.	Data Setup and Hold.....	9
Figure 5.	PR4 Powerdown and Warm Reset .....	9
Figure 6.	Test Mode .....	9
Figure 7.	AC-link Connections .....	10

---

Figure 8. Mixer Diagram .....	12
Figure 9. AC-link Input and Output Framing .....	13
Figure 10. Line Input (Replicate for Video and Aux) .....	36
Figure 11. Differential 2 VRMS CD Input .....	36
Figure 12. Differential 1 VRMS CD Input .....	36
Figure 13. Microphone Input .....	37
Figure 14. Microphone Pre-amplifier .....	37
Figure 15. PC_BEEP Input .....	37
Figure 16. Modem Connection .....	38
Figure 17. Alternate Line Output as Headphone Output .....	38
Figure 18. Stereo Output .....	38
Figure 19. Voltage Regulator .....	39
Figure 20. S/PDIF Output .....	40
Figure 21. Conceptual Layout for the CS4299 .....	41
Figure 22. Pin Locations for the CS4299 .....	42
Figure 23. CS4299 Reference Design .....	49

## LIST OF TABLES

Table 1. Mixer Registers .....	19
Table 2. Analog Mixer Output Attenuation .....	21
Table 3. Microphone Input Gain Values .....	23
Table 4. Analog Mixer Input Gain Values .....	24
Table 5. Stereo Volume Register Index .....	24
Table 6. Input Mux Selection .....	25
Table 7. Standard Sample Rates .....	29
Table 8. Slot Mapping .....	30
Table 9. Device ID with Corresponding Part Number .....	32
Table 10. Revision Values .....	32
Table 11. Powerdown PR Bit Functions .....	34
Table 12. Powerdown PR Function Matrix .....	35
Table 13. Power Consumption by Powerdown Mode .....	35

## 1. CHARACTERISTICS AND SPECIFICATIONS

**ANALOG CHARACTERISTICS** Standard test conditions unless otherwise noted:  $T_{\text{ambient}} = 25^{\circ}\text{C}$ ,  $AV_{\text{dd}} = 5.0\text{ V} \pm 5\%$ ,  $DV_{\text{dd}} = 3.3\text{ V} \pm 5\%$ ; 1 kHz Input Sine wave; Sample Frequency,  $F_s = 48\text{ kHz}$ ;  $Z_{\text{AL}} = 100\text{ k}\Omega / 1000\text{ pF}$  load,  $C_{\text{DL}} = 18\text{ pF}$  load (Note 1); Measurement bandwidth is 20 Hz - 20 kHz, 18-bit linear coding for ADC functions, 20-bit linear coding for DAC functions; Mixer registers set for unity gain.

Parameter (Note 2)	Symbol	Path (Note 3)	CS4299-KQ			CS4299-JQ			Unit
			Min	Typ	Max	Min	Typ	Max	
Full Scale Input Voltage									
Line Inputs		A-D	0.91	1.00	-	0.91	1.00	-	$V_{\text{RMS}}$
Mic Inputs		A-D	0.91	1.00	-	0.91	1.00	-	$V_{\text{RMS}}$
Mic Inputs (20 dB internal gain)		A-D	0.091	0.10	-	0.091	0.10	-	$V_{\text{RMS}}$
Full Scale Output Voltage									
Line, Alternate Line, and Mono Outputs		D-A	0.91	1.0	1.13	0.91	1.0	1.13	$V_{\text{RMS}}$
Frequency Response (Note 4)	FR								
Analog $A_c = \pm 0.5\text{ dB}$		A-A	20	-	20,000	20	-	20,000	Hz
DAC $A_c = \pm 0.5\text{ dB}$		D-A	20	-	20,000	20	-	20,000	Hz
ADC $A_c = \pm 0.5\text{ dB}$		A-D	20	-	20,000	20	-	20,000	Hz
Dynamic Range	DR								
Stereo Analog inputs to LINE_OUT		A-A	90	95	-	-	90	-	dB FS A
Mono Analog inputs to LINE_OUT		A-A	85	90	-	-	85	-	dB FS A
DAC Dynamic Range		D-A	85	90	-	-	87	-	dB FS A
ADC Dynamic Range		A-D	85	90	-	-	85	-	dB FS A
DAC SNR (-20 dB FS input w/ CCIR-RMS filter on output)	SNR	D-A	-	70	-	-	-	-	dB
Total Harmonic Distortion + Noise (-3 dB FS input signal):	THD+N								
Line/Alternate Line Output		A-A	-	-90	-80	-	-	-74	dB FS
DAC		D-A	-	-91	-80	-	-	-74	dB FS
ADC (all inputs except phone/mic)		A-D	-	-88	-80	-	-	-74	dB FS
ADC (phone/mic)		A-D	-	-84	-74	-	-	-74	dB FS
Power Supply Rejection Ratio (1 kHz, 0.5 $V_{\text{RMS}}$ w/ 5 V DC offset)(Note 4)			40	60	-	-	40	-	dB
Interchannel Isolation			70	88	-	-	88	-	dB
Spurious Tone (Note 4)			-	-100	-	-	-100	-	dB FS
Input Impedance (Note 4)			10	-	-	10	-	-	k $\Omega$
External Load Impedance			10	-	-	10	-	-	k $\Omega$
Output Impedance (Note 4)			-	730	-	-	730	-	$\Omega$
Input Capacitance (Note 4)			-	5	-	-	5	-	pF
Vrefout			2.0	2.28	2.5	2.0	2.28	2.5	V

- Notes:
1.  $Z_{\text{AL}}$  refers to the analog output pin loading and  $C_{\text{DL}}$  refers to the digital output pin loading.
  2. Parameter definitions are given in the Section 10, *Parameter and Term Definitions*.
  3. Path refers to the signal path used to generate this data. These paths are defined in the Section 10, *Parameter and Term Definitions*.
  4. This specification is guaranteed by silicon characterization, it is not production tested.

**MIXER CHARACTERISTICS** (for CS4299-KQ only)

Parameter	Min	Typ	Max	Unit
Mixer Gain Range Span Line In, Aux, CD, Video, Mic1, Mic2, Phone, PC Beep Mono Out, Alternate Line Out Line Out	-	46.5	-	dB
	-	46.5	-	dB
	-	94.5	-	dB
Step Size All volume controls except PC Beep PC Beep	-	1.5	-	dB
	-	3.0	-	dB

**ABSOLUTE MAXIMUM RATINGS** (AVss1 = AVss2 = DVss1 = DVss2 = 0 V)

Parameter	Min	Typ	Max	Unit
Power Supplies +3.3 V Digital +5 V Digital Analog	-0.3	-	6.0	V
	-0.3	-	6.0	V
	-0.3	-	6.0	V
Total Power Dissipation (Supplies, Inputs, Outputs)	-	-	1.25	W
Input Current per Pin (Except Supply Pins)	-10	-	10	mA
Output Current per Pin (Except Supply Pins)	-15	-	15	mA
Analog Input voltage	-0.3	-	AVdd+ 0.3	V
Digital Input voltage	-0.3	-	DVdd + 0.3	V
Ambient Temperature (Power Applied)	-55	-	110	°C
Storage Temperature	-65	-	150	°C

**RECOMMENDED OPERATING CONDITIONS** (AVss1 = AVss2 = DVss1 = DVss2 = 0 V)

Parameter	Symbol	Min	Typ	Max	Unit
Power Supplies +3.3 V Digital +5 V Digital Analog	DVdd1, DVdd2 DVdd1, DVdd2 AVdd1, AVdd2	3.135 4.75 4.75	3.3 5 5	3.465 5.25 5.25	V V V
Operating Ambient Temperature		0	-	70	°C

**DIGITAL CHARACTERISTICS** (AVss = DVss = 0 V)

Parameter	Symbol	Min	Typ	Max	Unit
Low level input voltage	V <sub>il</sub>	-	-	0.8	V
High level input voltage	V <sub>ih</sub>	0.65 x DVdd	-	-	V
High level output voltage	V <sub>oh</sub>	0.90 x DVdd	0.99 x DVdd	-	V
Low level output voltage	V <sub>ol</sub>	-	0.03	0.10 x DVdd	V
Input Leakage Current (AC-link inputs)		-10	-	10	µA
Output Leakage Current (Tri-stated AC-link outputs)		-10	-	10	µA
Output buffer drive current BIT_CLK, S/PDIF_OUT SDATA_IN, EAPD (Note 4)		-	24 4	-	mA mA

**AC '97 SERIAL PORT TIMING** Standard test conditions unless otherwise noted:  $T_{\text{ambient}} = 25^{\circ}\text{C}$ ,  
 $AV_{\text{dd}} = 5.0\text{V}$ ,  $DV_{\text{dd}} = 3.3\text{V}$ ;  $C_L = 55\text{pF}$  load.

Parameter	Symbol	Min	Typ	Max	Unit
<b>RESET Timing</b>					
RESET# active low pulse width	$T_{\text{rst\_low}}$	1.0	-	-	$\mu\text{s}$
RESET# inactive to BIT_CLK start-up delay	$T_{\text{rst2clk}}$	-	40.0	-	$\mu\text{s}$
1st SYNC active to CODEC READY set	$T_{\text{sync2crd}}$	-	62.5	-	$\mu\text{s}$
Vdd stable to Reset inactive	$T_{\text{vdd2rst\#}}$	100	-	-	$\mu\text{s}$
<b>Clocks</b>					
BIT_CLK frequency	$F_{\text{clk}}$	-	12.288	-	MHz
BIT_CLK period	$T_{\text{clk\_period}}$	-	81.4	-	ns
BIT_CLK output jitter (depends on XTAL_IN source)		-	-	750	ps
BIT_CLK high pulse width	$T_{\text{clk\_high}}$	36	40.7	45	ns
BIT_CLK low pulse width	$T_{\text{clk\_low}}$	36	40.7	45	ns
SYNC frequency	$F_{\text{sync}}$	-	48	-	kHz
SYNC period	$T_{\text{sync\_period}}$	-	20.8	-	$\mu\text{s}$
SYNC high pulse width	$T_{\text{sync\_high}}$	-	1.3	-	$\mu\text{s}$
SYNC low pulse width	$T_{\text{sync\_low}}$	-	19.5	-	$\mu\text{s}$
<b>Data Setup and Hold</b>					
Output Propagation delay from rising edge of BIT_CLK	$T_{\text{co}}$	-	6	8	ns
Input setup time from falling edge of BIT_CLK	$T_{\text{isetaup}}$	10	-	-	ns
Input hold time from falling edge of BIT_CLK	$T_{\text{ihold}}$	0	-	-	ns
Input Signal rise time	$T_{\text{irise}}$	2	-	6	ns
Input Signal fall time	$T_{\text{ifall}}$	2	-	6	ns
Output Signal rise time (Note 4)	$T_{\text{orise}}$	2	4	6	ns
Output Signal fall time (Note 4)	$T_{\text{ofall}}$	2	4	6	ns
<b>Misc. Timing Parameters</b>					
End of Slot 2 to BIT_CLK, SDATA_IN low (PR4)	$T_{\text{s2\_pdown}}$	-	.28	1.0	$\mu\text{s}$
SYNC pulse width (PR4) Warm Reset	$T_{\text{sync\_pr4}}$	1.0	-	-	$\mu\text{s}$
SYNC inactive (PR4) to BIT_CLK start-up delay	$T_{\text{sync2clk}}$	162.8	285	-	ns
Setup to trailing edge of RESET# (ATE test mode) (Note 4)	$T_{\text{setup2rst}}$	15	-	-	ns
Rising edge of RESET# to Hi-Z delay (Note 4)	$T_{\text{off}}$	-	-	25	ns

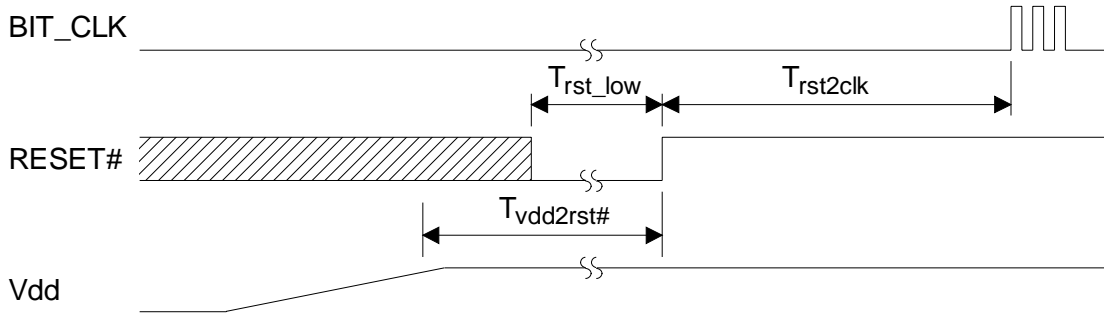

**Figure 1. Power Up Timing**

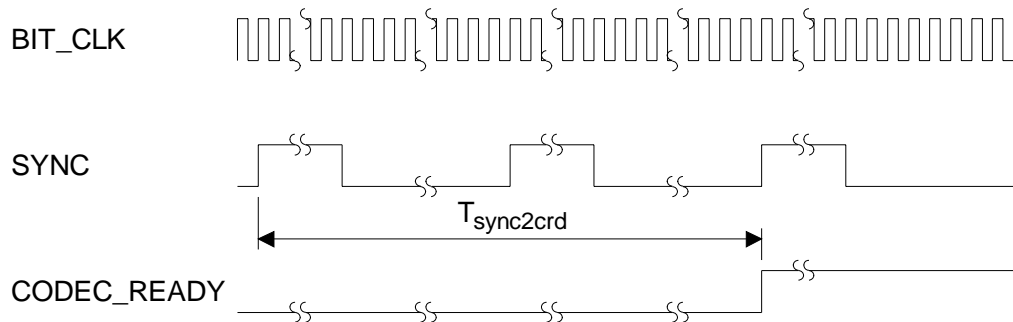

**Figure 2. Codec Ready from Startup or Fault Condition**

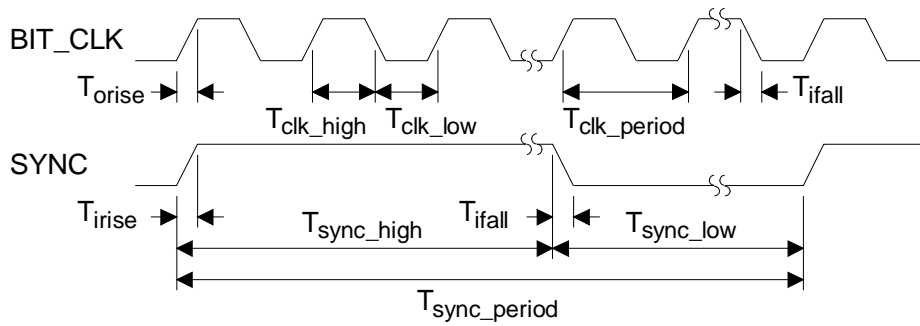

**Figure 3. Clocks**

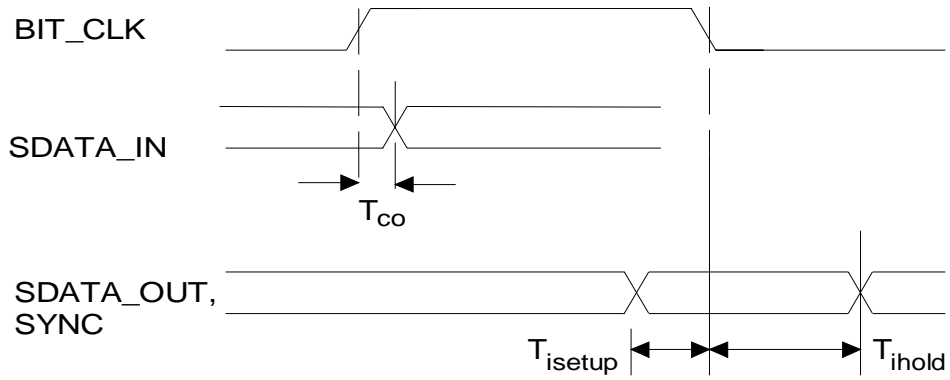

**Figure 4. Data Setup and Hold**

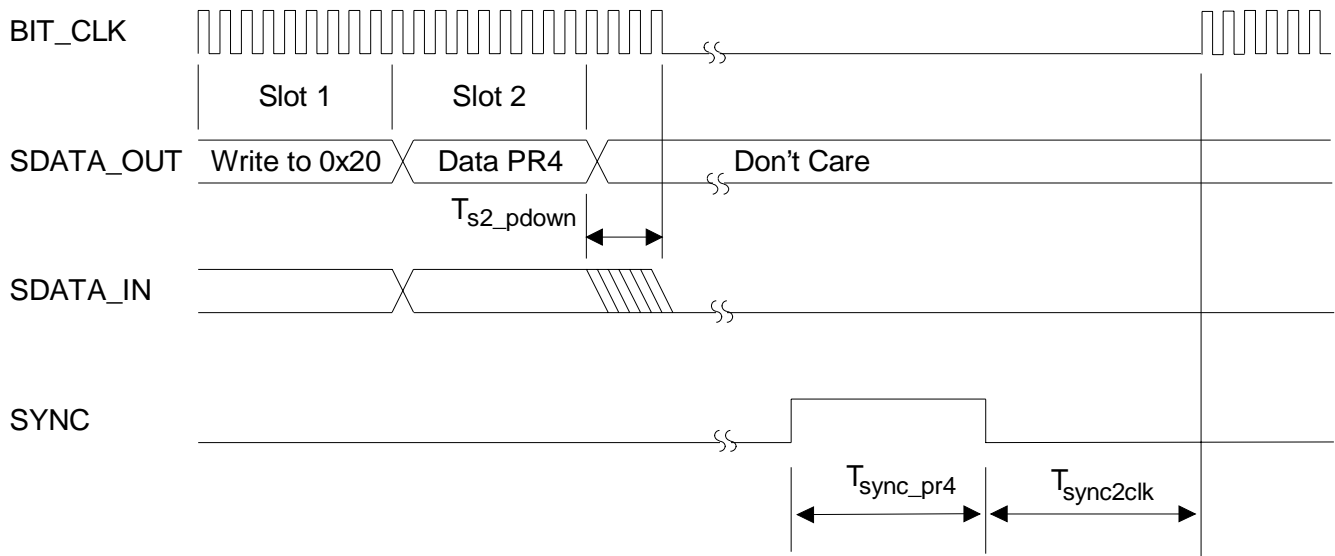

**Figure 5. PR4 Powerdown and Warm Reset**

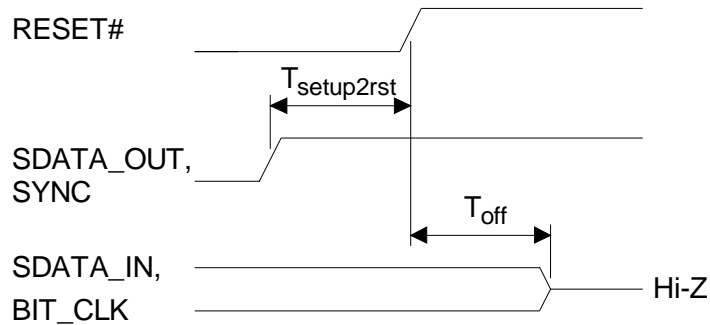

**Figure 6. Test Mode**

## 2. GENERAL DESCRIPTION

The CS4299 is a mixed-signal serial audio Codec compliant to the Intel® *Audio Codec '97 Specification*, revision 2.1 [1]. It is designed to be paired with a digital controller, typically located on the PCI bus or integrated within the system core logic chip set. The controller is responsible for all communications between the CS4299 and the remainder of the system. The CS4299 contains two distinct functional sections: digital and analog. The digital section includes the AC-link interface, S/PDIF interface, serial data port, Sample Rate Converters, and power management support. The analog section includes the analog input multiplexer (mux), stereo output mixer, mono output mixer, stereo Analog-to-Digital Converters (ADCs), stereo Digital-to-Analog Converters (DACs), and their associated volume controls.

### 2.1 AC-Link

All communication with the CS4299 is established with a 5-wire digital interface to the controller, as shown in Figure 7. This interface is called the AC-link. All clocking for the serial communication is synchronous to the BIT\_CLK signal. BIT\_CLK is generated by the primary audio codec and is used to clock the controller and any secondary audio co-

decs. Both input and output AC-link audio frames are organized as a sequence of 256 serial bits forming 13 groups referred to as 'slots'. During each audio frame, data is passed bi-directionally between the CS4299 and the controller. The input frame is driven from the CS4299 on the SDATA\_IN line. The output frame is driven from the controller on the SDATA\_OUT line. The controller is also responsible for issuing reset commands via the RESET# signal. Following a Cold Reset, the CS4299 is responsible for notifying the controller that it is ready for operation after synchronizing its internal functions. The CS4299 AC-link signals must use the same digital supply voltage as the controller chip, either +5 V or +3.3 V. See Section 3, *AC Link Frame Definition*, for detailed AC-link information.

### 2.2 Control registers

The CS4299 contains a set of AC '97 compliant control registers and a set of Cirrus Logic defined control registers. These registers control the basic functions and features of the CS4299. Read accesses of the control registers by the AC '97 controller are accomplished with the requested register index in Slot 1 of a SDATA\_OUT frame. The following SDATA\_IN frame will contain the read data in its

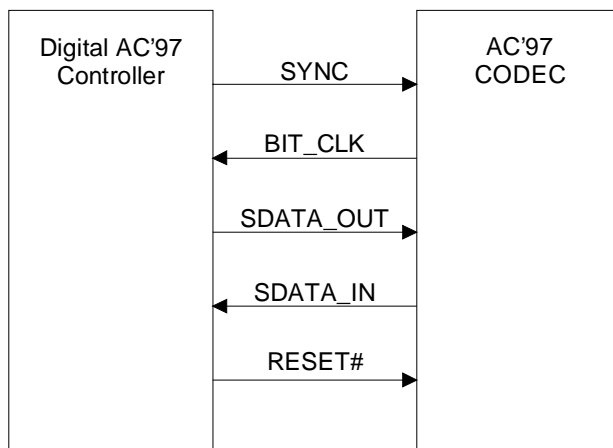

Figure 7. AC-link Connections

Slot 2. Write operations are similar, with the register index in Slot 1 and the write data in Slot 2 of a `SDATA_OUT` frame. The function of each input and output frame is detailed in Section 3, *AC Link Frame Definition*. Individual register descriptions are found in Section 4, *Register Interface*.

### 2.3 Sample Rate Converters

The Sample Rate Converters (SRCs) provide high accuracy digital filters supporting sample frequencies other than 48 kHz to be captured from the CS4299 or played from the controller. AC '97 requires support for two audio rates (44.1 and 48kHz). In addition, the Intel<sup>®</sup> I/O Controller Hub (ICHx) specification requires support for five more audio rates (8, 11.025, 16, 22.05, and 32). The CS4299 supports all these rate, as shown in Table 7 on page 29.

### 2.4 Output Mixer

The CS4299 has two output mixers, illustrated in Figure 8. The stereo output mixer sums together the analog inputs to the CS4299, including the `PC_BEEP` and `PHONE` signals, according to the settings in the volume control registers. The stereo output mix is sent to the `LINE_OUT` and

`ALT_LINE_OUT` pins on the CS4299. The mono output mixer generates a monophonic sum of the left and right channels from the stereo input mixer. The mono output mix is sent to the `MONO_OUT` output pin on the CS4299.

### 2.5 Input Mux

The input multiplexer controls which analog input is sent to the ADCs. The output of the input mux is converted to stereo 18-bit digital PCM data and sent to the controller by means of the AC-link `SDATA_IN` signal.

### 2.6 Volume Control

The CS4299 volume registers control analog input levels to the input mixer and analog output levels, including the master volume level, and the alternate volume level. The `PC_BEEP` volume control uses 3 dB steps with a range of 0 dB to -45 dB attenuation. All other analog volume controls use 1.5 dB steps. The analog inputs have a mixing range of +12 dB signal gain to -34.5 dB signal attenuation. The analog output volume controls have from 0 dB to -94.5 dB attenuation for `LINE_OUT` and from 0 dB to -46.5 dB attenuation for `ALT_LINE_OUT` and `MONO_OUT`.

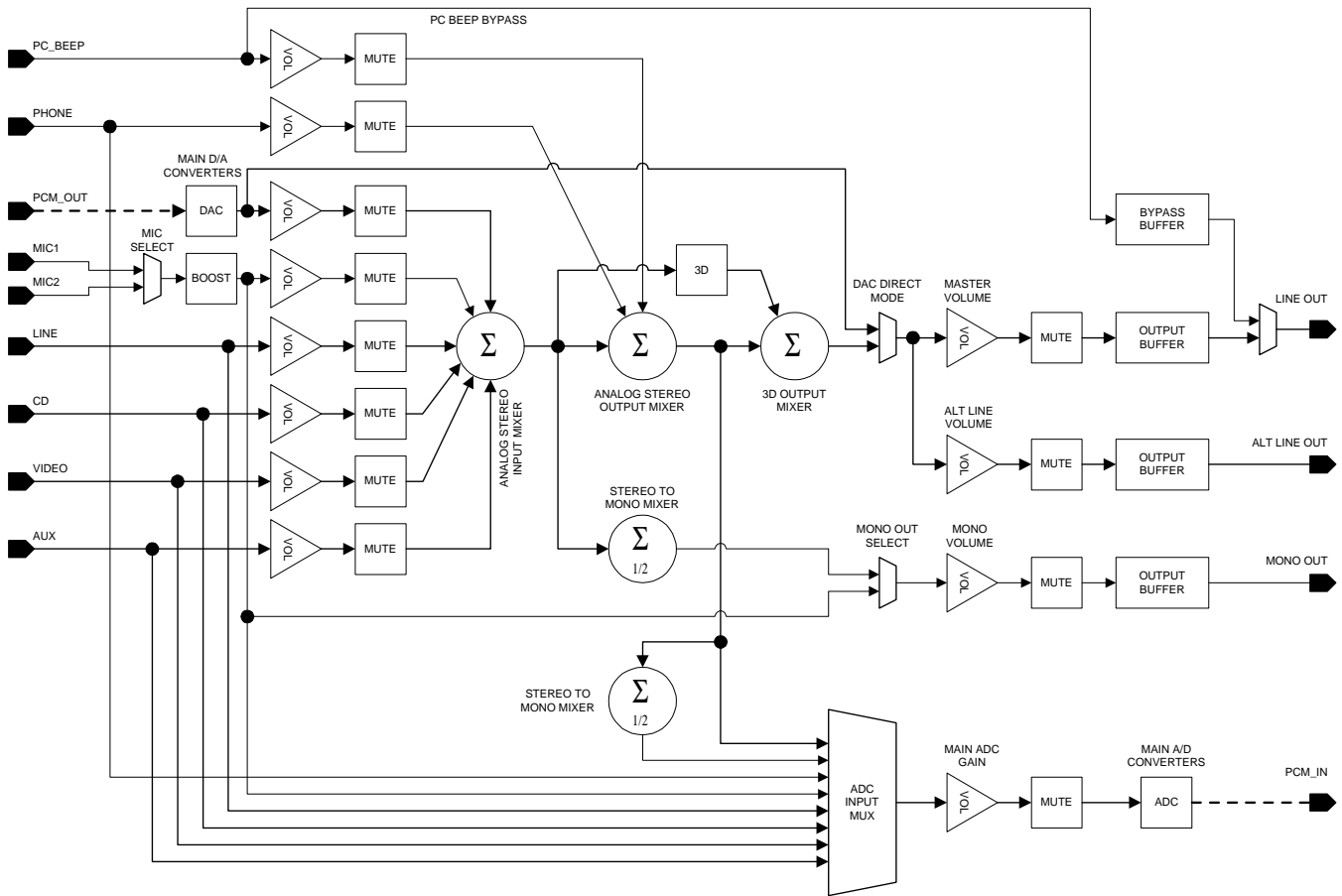

**Figure 8. Mixer Diagram**

### 3. AC LINK FRAME DEFINITION

The AC-link is a bidirectional serial port with data organized into frames consisting of one 16-bit and twelve 20-bit time-division multiplexed slots. The first slot, called the tag slot, contains bits indicating if the CS4299 is ready to receive data (input frame) and which, if any, other slots contain valid data. Slots 1 through 12 contain audio or control/status data. Both the serial data output and input frames are defined from the controller perspective, not from the CS4299 perspective.

The controller synchronizes the beginning of a frame with the assertion of the SYNC signal.

Figure 9 shows the position of each bit location within the frame. The first bit position in a new serial data frame is F0 and the last bit position in the serial data frame is F255. When SYNC goes active (high) and is sampled active by the CS4299 (on the falling edge of BIT\_CLK), both devices are synchronized to a new serial data frame. The data on the SDATA\_OUT pin at this clock edge is the final bit of the previous frame's serial data. On the next rising edge of BIT\_CLK, the first bit of Slot 0 is driven by the controller on the SDATA\_OUT pin. On the next falling edge of BIT\_CLK, the CS4299 latches this data in, as the first bit of the frame.

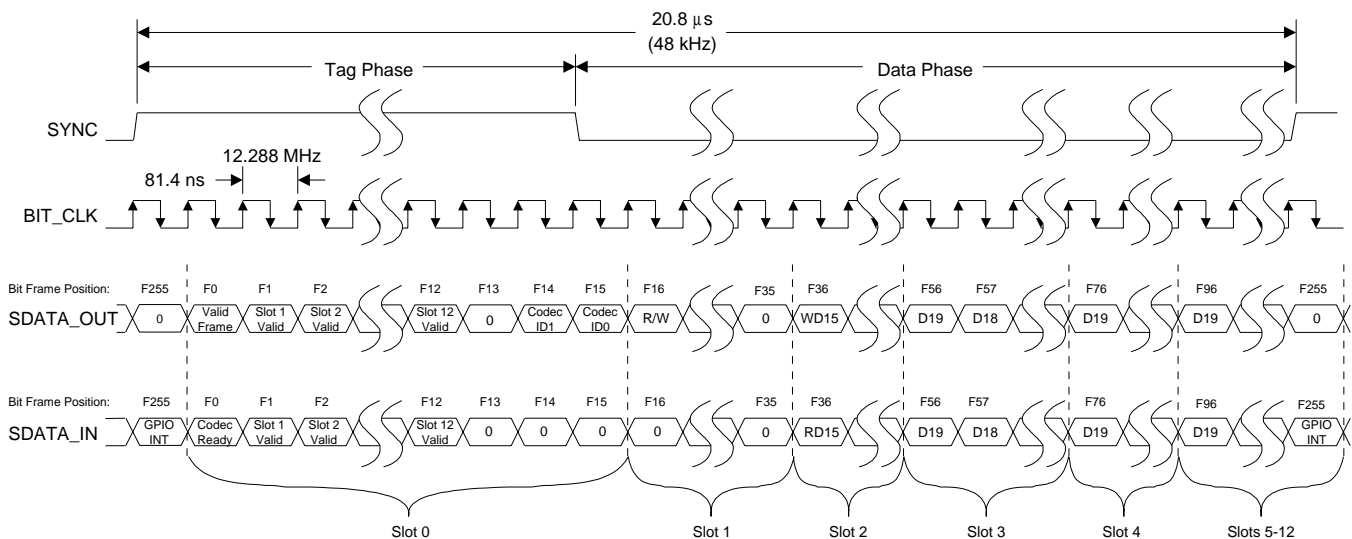

**Figure 9. AC-link Input and Output Framing**

### 3.1 AC-Link Serial Data Output Frame

In the serial data output frame, data is passed on the SDATA\_OUT pin to the CS4299 from the AC '97 controller. Figure 9 illustrates the serial port timing.

The PCM playback data being passed to the CS4299 is shifted out MSB first in the most significant bits of each slot. Any PCM data from the AC '97 controller that is not 20 bits wide should be left justified in its corresponding slot and dithered or zero-padded in the unused bit positions.

Bits that are reserved should always be 'cleared' by the AC '97 controller.

#### 3.1.1 Serial Data Output Slot Tags (Slot 0)

Bit 15	14	13	12	11	10	9	8	7	6	5	4	3	2	1	0
Valid Frame	Slot 1 Valid	Slot 2 Valid	Slot 3 Valid	Slot 4 Valid	Slot 5 Valid	Slot 6 Valid	Slot 7 Valid	Slot 8 Valid	Slot 9 Valid	Slot 10 Valid	Reserved			Codec ID1	Codec ID0

- Valid Frame            The Valid Frame bit determines if any of the following slots contain either valid playback data for the CS4299 DACs or data for read/write operations. When 'set', at least one of the other AC-link slots contain valid data. If this bit is 'clear', the remainder of the frame is ignored.
  
- Slot [1:2] Valid        The Slot [1:2] Valid bits indicate the validity of data in their corresponding serial data output slots. If a bit is 'set', the corresponding output slot contains valid data. If a bit is 'cleared', the corresponding slot will be ignored.
  
- Slot [3:10] Valid      The Slot [3:10] Valid bits indicate Slot [3:10] contains valid playback data for the CS4299. If a Slot Valid bit is 'set', the named slot contains valid audio data. If the bit is 'clear', the slot will be ignored. The CS4299 supports alternate slot mapping as defined in the AC '97 2.1 specification. For more information, see the *AC Mode Control Register (Index 5Eh)*.
  
- Codec ID[1:0]         The Codec ID[1:0] bits display the Codec ID of the audio codec being accessed during the current AC-link frame. Codec ID[1:0] = 00 indicates the primary codec is being accessed. Codec ID[1:0] = 01, 10, or 11 indicates one of three possible secondary codecs is being accessed. A non-zero value of one or more of the Codec ID bits indicates a valid Read or Write Address in Slot 1, and the Slot 1 R/W bit indicates presence or absence of valid Data in Slot 2.

### 3.1.2 Command Address Port (Slot 1)

Bit 19	18	17	16	15	14	13	12	11	10	9	8	7	6	5	4	3	2	1	0
R/W	RI6	RI5	RI4	RI3	RI2	RI1	RI0	0	0	0	0	0	0	0	0	0	0	0	0

**R/W** Read/Write. When this bit is 'set', a read of the AC '97 register specified by the register index bits will occur in the AC '97 2.1 audio codec. When the bit is 'cleared', a write will occur. For any read or write access to occur, the Frame Valid bit (F0) must be 'set' and the Codec ID[1:0] bits (F[14:15]) must match the Codec ID of the AC '97 2.1 audio codec being accessed. Additionally, for a primary codec, the Slot 1 Valid bit (F1) must be 'set' for a read access and both the Slot 1 Valid bit (F1) and the Slot 2 Valid bit (F2) must be 'set' for a write access. For a secondary codec, both the Slot 1 Valid bit (F1) and the Slot 2 Valid bit (F2) must be 'cleared' for read and write accesses. See Figure 9 for bit frame positions.

**RI[6:0]** Register Index. The RI[6:0] bits contain the 7-bit register index to the AC '97 registers in the CS4299. All registers are defined at word addressable boundaries. The RI0 bit must be 'clear' to access CS4299 registers.

### 3.1.3 Command Data Port (Slot 2)

Bit 19	18	17	16	15	14	13	12	11	10	9	8	7	6	5	4	3	2	1	0
WD15	WD14	WD13	WD12	WD11	WD10	WD9	WD8	WD7	WD6	WD5	WD4	WD3	WD2	WD1	WD0	Reserved			

**WD[15:0]** Write Data. The WD[15:0] bits contain the 16-bit value to be written to the register. If an access is a read, this slot is ignored.

**NOTE:** For any write to an AC '97 register, the write is defined to be an 'atomic' access. This means that when the Slot 1 Valid bit in output Slot 0 is 'set', the Slot 2 Valid bit in output slot 0 should always be 'set' during the same audio frame. No write access may be split across 2 frames.

### 3.1.4 PCM Playback Data (Slots 3-10)

Bit 19	18	17	16	15	14	13	12	11	10	9	8	7	6	5	4	3	2	1	0
PD19	PD18	PD17	PD16	PD15	PD14	PD13	PD12	PD11	PD10	PD9	PD8	PD7	PD6	PD5	PD4	PD3	PD2	PD1	PD0

**PD[19:0]** Playback Data. The PD[19:0] bits contain the 20-bit PCM playback (2's complement) data for the left and right DACs and/or the S/PDIF transmitter. Table 8 on page 30 lists a cross reference for each function and its respective slot. The mapping of a given slot to a DAC is determined by the state of the ID[1:0] bits in the *Extended Audio ID Register (Index 28h)* and by the SM[1:0] and AMAP bits in the *AC Mode Control Register (Index 5Eh)*.

### 3.2 AC-Link Audio Input Frame

In the serial data input frame, data is passed on the SDATA\_IN pin from the CS4299 to the AC '97 controller. The data format for the input frame is very similar to the output frame. Figure 9 on page 13 illustrates the serial port timing.

The PCM capture data from the CS4299 is shifted out MSB first in the most significant 18 bits of each slot. The least significant 2 bits in each slot will be 'cleared'. If the host requests PCM data from the AC '97 Controller that is less than 18 bits wide, the controller should dither and round or just round (but not truncate) to the desired bit depth.

Bits that are reserved or not implemented in the CS4299 will always be returned 'cleared'.

#### 3.2.1 Serial Data Input Slot Tag Bits (Slot 0)

Bit 15	14	13	12	11	10	9	8	7	6	5	4	3	2	1	0
Codec Ready	Slot 1 Valid	Slot 2 Valid	Slot 3 Valid	Slot 4 Valid	Slot 5 Valid	Slot 6 Valid	Slot 7 Valid	Slot 8 Valid	Slot 9 Valid	Slot 10 Valid	0	0	0	0	0

**Codec Ready** The Codec Ready bit indicates the readiness of the CS4299 AC-link. Immediately after a Cold Reset this bit will be 'clear'. Once the CS4299 clocks and voltages are stable, this bit will be 'set'. Until the Codec Ready bit is 'set', no AC-link transactions should be attempted by the controller. The Codec Ready bit does not indicate readiness of the DACs, ADCs, Vref, or any other analog function. Those must be checked in the *Powerdown Control/Status Register (Index 26h)* by the controller before any access is made to the mixer registers. Any accesses to the CS4299 while Codec Ready is 'clear' are ignored.

**Slot 1 Valid** When 'set', the Slot 1 Valid bit indicates Slot 1 contains a valid read back address.

**Slot 2 Valid** When 'set', the Slot 2 Valid bit indicates Slot 2 contains valid register read data.

**Slot [3:10] Valid** When 'set', the Slot [3:10] Valid bits indicate Slot [3:10] contains valid capture data from the CS4299 ADCs. Only if a Slot [3:10] Valid bit is 'set' will the corresponding input slot contain valid data.

#### 3.2.2 Status Address Port (Slot 1)

Bit 19	18	17	16	15	14	13	12	11	10	9	8	7	6	5	4	3	2	1	0
0	RI6	RI5	RI4	RI3	RI2	RI1	RI0	SR3	SR4	SR5	SR6	SR7	SR8	SR9	SR10	0	Reserved		

**RI[6:0]** Register Index. The RI[6:0] bits echo the AC '97 register address when a register read has been requested in the previous frame. The CS4299 will only echo the register index for a read access. Write accesses will not return valid data in Slot 1.

**SR[3:10]** Slot Request. If SRx is 'set', this indicates the CS4299 SRC does not need a new sample on the next AC-link frame for that particular slot. If SRx is 'clear', the SRC indicates a new sample is needed on the following frame. If the VRA bit in the *Extended Audio Status/Control Register (Index 2Ah)* is 'clear', the SR[3:10] bits are always 0. When VRA is 'set', the SRC is enabled and the SR[3:10] bits are used to request data.

### 3.2.3 Status Data Port (Slot 2)

Bit 19	18	17	16	15	14	13	12	11	10	9	8	7	6	5	4	3	2	1	0
RD15	RD14	RD13	RD12	RD11	RD10	RD9	RD8	RD7	RD6	RD5	RD4	RD3	RD2	RD1	RD0	Reserved			

**RD[15:0]** Read Data. The RD[15:0] bits contain the register data requested by the controller from the previous read request. All read requests will return the read address in the input Slot 1 and the register data in the input Slot 2 on the following serial data frame.

### 3.2.4 PCM Capture Data (Slot 3-10)

Bit 19	18	17	16	15	14	13	12	11	10	9	8	7	6	5	4	3	2	1	0
CD17	CD16	CD15	CD14	CD13	CD12	CD11	CD10	CD9	CD8	CD7	CD6	CD5	CD4	CD3	CD2	CD1	CD0	0	0

**CD[17:0]** Capture Data. The D[17:0] bits contain 18-bit PCM (2's complement) capture data. The mapping of a given slot to an ADC is determined by the state of the ID[1:0] bits in the *Extended Audio ID Register (Index 28h)* and the SM[1:0] and AMAP bits in the *AC Mode Control Register (Index 5Eh)*. The definition of each slot can be found in Table 8 on page 30.

### 3.3 AC-Link Protocol Violation - Loss of SYNC

The CS4299 is designed to handle SYNC protocol violations. The following are situations where the SYNC protocol has been violated:

- The SYNC signal is not sampled high for exactly 16 BIT\_CLK clock cycles at the start of an audio frame.
- The SYNC signal is not sampled high on the 256th BIT\_CLK clock period after the previous SYNC assertion.
- The SYNC signal goes active high before the 256th BIT\_CLK clock period after the previous SYNC assertion.

Upon loss of synchronization with the controller, the CS4299 will ‘clear’ the Codec Ready bit in the serial data input frame until two valid frames are detected. During this detection period, the CS4299 will ignore all register reads and writes and will discontinue the transmission of PCM capture data. In addition, if the LOSM bit in the *Misc. Crystal Control Register (Index 60h)* is ‘set’ (default), the CS4299 will mute all analog outputs. If the LOSM bit is ‘clear’, the analog outputs will not be muted.

**4. REGISTER INTERFACE**

Reg	Register Name	D15	D14	D13	D12	D11	D10	D9	D8	D7	D6	D5	D4	D3	D2	D1	D0	Default	
00h	Reset	0	SE4	SE3	SE2	SE1	SE0	0	ID8	ID7	0	0	ID4	0	0	0	0	1990h	
02h	Master Volume	Mute	0	ML5	ML4	ML3	ML2	ML1	ML0	0	0	MR5	MR4	MR3	MR2	MR1	MR0	8000h	
04h	Alternate Volume	Mute	0	ML5	ML4	ML3	ML2	ML1	ML0	0	0	MR5	MR4	MR3	MR2	MR1	MR0	8000h	
06h	Mono Volume	Mute	0	0	0	0	0	0	0	0	0	MM5	MM4	MM3	MM2	MM1	MM0	8000h	
0Ah	PC_BEEP Volume	Mute	0	0	0	0	0	0	0	0	0	0	PV3	PV2	PV1	PV0	0	0000h	
0Ch	Phone Volume	Mute	0	0	0	0	0	0	0	0	0	0	GN4	GN3	GN2	GN1	GN0	8008h	
0Eh	Mic Volume	Mute	0	0	0	0	0	0	0	0	20dB	0	GN4	GN3	GN2	GN1	GN0	8008h	
10h	Line In Volume	Mute	0	0	GL4	GL3	GL2	GL1	GL0	0	0	0	GR4	GR3	GR2	GR1	GR0	8808h	
12h	CD Volume	Mute	0	0	GL4	GL3	GL2	GL1	GL0	0	0	0	GR4	GR3	GR2	GR1	GR0	8808h	
14h	Video Volume	Mute	0	0	GL4	GL3	GL2	GL1	GL0	0	0	0	GR4	GR3	GR2	GR1	GR0	8808h	
16h	Aux Volume	Mute	0	0	GL4	GL3	GL2	GL1	GL0	0	0	0	GR4	GR3	GR2	GR1	GR0	8808h	
18h	PCM Out Volume	Mute	0	0	GL4	GL3	GL2	GL1	GL0	0	0	0	GR4	GR3	GR2	GR1	GR0	8808h	
1Ah	Record Select	0	0	0	0	0	SL2	SL1	SL0	0	0	0	0	0	SR2	SR1	SR0	0000h	
1Ch	Record Gain	Mute	0	0	0	GL3	GL2	GL1	GL0	0	0	0	0	GR3	GR2	GR1	GR0	8000h	
20h	General Purpose	0	0	3D	0	0	0	MIX	MS	LPBK	0	0	0	0	0	0	0	0000h	
22h	3D Control	0	0	0	0	0	0	0	0	0	0	0	0	S3	S2	S1	S0	0000h	
26h	Powerdown Ctrl/Stat	EAPD	PR6	PR5	PR4	PR3	PR2	PR1	PR0	0	0	0	0	REF	ANL	DAC	ADC	000Fh	
28h	Extended Audio ID	ID1	ID0	0	0	0	0	AMAP	0	0	0	0	0	0	0	0	0	VRA	0201h
2Ah	Extended Audio Ctrl/Stat	0	0	0	0	0	0	0	0	0	0	0	0	0	0	0	0	VRA	0000h
2Ch	PCM Front DAC Rate	SR15	SR14	SR13	SR12	SR11	SR10	SR9	SR8	SR7	SR6	SR5	SR4	SR3	SR2	SR1	SR0	BB80h	
32h	PCM L/R ADC Rate	SR15	SR14	SR13	SR12	SR11	SR10	SR9	SR8	SR7	SR6	SR5	SR4	SR3	SR2	SR1	SR0	BB80h	
<b>Cirrus Logic Defined Registers:</b>																			
5E	AC Mode Control	0	0	0	0	0	0	0	DDM	AMAP	0	SM1	SM0	0	0	0	0	0080h	
60	Misc. Crystal Control	0	0	0	0	Reserved				0	0	Reserved		0	Reserved			LOSM	0023h
68	S/PDIF Control	SPEN	Val	0	Fs	L	CC6	CC5	CC4	CC3	CC2	CC1	CC0	Emph	Copy	/Audio	Pro	0000h	
7Ch	Vendor ID1(CR)	F7	F6	F5	F4	F3	F4	F1	F0	S7	S6	S5	S4	S3	S2	S1	S0	4352h	
7Eh	Vendor ID2(Y-)	T7	T6	T5	T4	T3	T2	T1	T0	0	DID2	DID1	DID0	0	REV2	REV1	REV0	5931h	

**Table 1. Mixer Registers**

#### 4.1 Reset Register (Index 00h)

D15	D14	D13	D12	D11	D10	D9	D8	D7	D6	D5	D4	D3	D2	D1	D0
0	SE4	SE3	SE2	SE1	SE0	0	ID8	ID7	0	0	ID4	0	0	0	0

- SE[4:0]            Crystal 3D Stereo Enhancement. SE[4:0] = 00110, indicating this feature is present.
- ID8                18-bit ADC Resolution. The ID8 bit is 'set', indicating this feature is present.
- ID7                20-bit DAC resolution. The ID7 bit is 'set', indicating this feature is present.
- ID4                Headphone Output (Alt Line Out). The ID4 bit is 'set', indicating this feature is present.
- Default            1990h. The data in this register is read-only data.

Any write to this register causes a Register Reset to the default state of the audio (*Index 00h - 38h*) and vendor specific (*Index 5Ah - 7Ah*) registers. A read from this register returns configuration information about the CS4299.

#### 4.2 Master Volume Register (Index 02h)

D15	D14	D13	D12	D11	D10	D9	D8	D7	D6	D5	D4	D3	D2	D1	D0
Mute	0	ML5	ML4	ML3	ML2	ML1	ML0	0	0	MR5	MR4	MR3	MR2	MR1	MR0

- Mute                Master Mute. Setting this bit mutes the LINE\_OUT\_L/R output signals.
- ML[5:0]            Master Volume Left. These bits control the left master output volume. Each step corresponds to 1.5 dB gain adjustment, with 00000 = 0 dB. The total range is 0 dB to -94.5 dB attenuation.
- MR[5:0]            Master Volume Right. These bits control the right master output volume. Each step corresponds to 1.5 dB gain adjustment, with 00000 = 0 dB. The total range is 0 dB to -94.5 dB attenuation.
- Default            8000h. This value corresponds to 0 dB attenuation and Mute 'set'.

### 4.3 Alternate Volume Register (Index 04h)

D15	D14	D13	D12	D11	D10	D9	D8	D7	D6	D5	D4	D3	D2	D1	D0
Mute	0	<u>ML5</u>	ML4	ML3	ML2	ML1	ML0	0	0	<u>MR5</u>	MR4	MR3	MR2	MR1	MR0

- Mute** Alternate Mute. Setting this bit mutes the ALT\_LINE\_OUT\_L/R output signals.
- ML[4:0]** Alternate Volume Left. These bits control the left alternate output volume. Each step corresponds to 1.5 dB gain adjustment, with 00000 = 0 dB. The total range is 0 dB to -46.5 dB attenuation. See Table 2 for further attenuation levels.
- ML5** Alternate Volume Left Max Attenuation. Setting ML5 sets the left channel attenuation to -46.5 dB by forcing ML[4:0] to a '1' state. ML[5:0] will read back 011111 when ML5 has been 'set'. Table 2 summarizes this behavior.
- MR[4:0]** Alternate Volume Right. These bits control the right alternate output volume. Each step corresponds to 1.5 dB gain adjustment, with 00000 = 0 dB. The total range is 0 dB to -46.5 dB attenuation. See Table 2 for further attenuation levels.
- MR5** Alternate Volume Right Max Attenuation. Setting MR5 sets the right channel attenuation to -46.5 dB by forcing MR[4:0] to a '1' state. MR[5:0] will read back 011111 when MR5 has been 'set'. Table 2 summarizes this behavior.
- Default** 8000h. This value corresponds to 0 dB attenuation and Mute 'set'.

Mx[5:0] Write	Mx[5:0] Read	Gain Level
000000	000000	0 dB
000001	000001	-1.5 dB
...	...	...
011111	011111	-46.5 dB
100000	011111	-46.5 dB
...	...	...
111111	011111	-46.5 dB

**Table 2. Analog Mixer Output Attenuation**

### 4.4 Mono Volume Register (Index 06h)

D15	D14	D13	D12	D11	D10	D9	D8	D7	D6	D5	D4	D3	D2	D1	D0
Mute	0	0	0	0	0	0	0	0	0	<u>MM5</u>	MM4	MM3	MM2	MM1	MM0

- Mute** Mono Mute. Setting this bit mutes the MONO\_OUT signal.
- MM[5:0]** Mono Volume. These bits control the mono output volume. Each step corresponds to 1.5 dB gain adjustment, with a total available range from 0 dB to -46.5 dB attenuation. See Table 2 for further attenuation levels.
- MM5** Mono Volume Max Attenuation. Setting the MM5 bit sets the mono attenuation to -46.5 dB by forcing MM[4:0] to a '1' state. MM[5:0] will read back 011111 when MM5 has been 'set'. Table 2 summarizes this behavior.
- Default** 8000h. This value corresponds to 0 dB attenuation and Mute 'set'.

#### 4.5 PC\_BEEP Volume Register (Index 0Ah)

D15	D14	D13	D12	D11	D10	D9	D8	D7	D6	D5	D4	D3	D2	D1	D0
Mute	0	0	0	0	0	0	0	0	0	0	PV3	PV2	PV1	PV0	0

**Mute**                      PC\_BEEP Mute. Setting this bit mutes the PC\_BEEP input signal.

**PV[3:0]**                    PC\_BEEP Volume Control. The PV[3:0] bits are used to control the gain levels of the PC\_BEEP input source to the Input Mixer. Each step corresponds to 3 dB gain adjustment, with 0000 = 0 dB. The total range is 0 dB to -45 dB attenuation.

**Default**                    0000h. This value corresponds to 0 dB attenuation and Mute 'clear'.

This register has no effect on the PC\_BEEP volume during RESET#.

#### 4.6 Phone Volume Register (Index 0Ch)

D15	D14	D13	D12	D11	D10	D9	D8	D7	D6	D5	D4	D3	D2	D1	D0
Mute	0	0	0	0	0	0	0	0	0	0	GN4	GN3	GN2	GN1	GN0

**Mute**                      Phone Mute. Setting this bit mutes the Phone input signal.

**GN[4:0]**                    Phone Volume Control. The GN[4:0] bits are used to control the gain levels of the Phone input source to the Input Mixer. Each step corresponds to 1.5 dB gain adjustment, with 01000 = 0 dB. The total range is +12 dB to -34.5 dB gain. See Table 4 on page 24 for further details.

**Default**                    8008h. This value corresponds to 0 dB gain and Mute 'set'.

#### 4.7 Microphone Volume Register (Index 0Eh)

D15	D14	D13	D12	D11	D10	D9	D8	D7	D6	D5	D4	D3	D2	D1	D0
Mute	0	0	0	0	0	0	0	0	20dB	0	GN4	GN3	GN2	GN1	GN0

**Mute** Microphone Mute. Setting this bit mutes the MIC1 or MIC2 signal. The selection of the MIC1 or MIC2 input pin is controlled by the MS bit in the *General Purpose Register (Index 20h)*.

**GN[4:0]** Microphone Volume Control. The GN[4:0] bits are used to control the gain level of the Microphone input source to the Input Mixer. Each step corresponds to 1.5 dB gain adjustment, with 01000 = 0 dB. The total range is +12 dB to -34.5 dB gain. See Table 3 for further details.

**20dB** Microphone 20 dB Boost. When 'set', the 20dB bit enables the +20 dB microphone boost block. This bit allows for variable boost of 0 dB or +20 dB. Table 3 summarizes this behavior.

**Default** 8008h. This value corresponds to 0 dB gain and Mute 'set'.

GN[4:0]	Gain Level	
	20dB = 0	20dB = 1
00000	+12.0 dB	+32.0 dB
00001	+10.5 dB	+30.5 dB
...	...	...
00111	+1.5 dB	+21.5 dB
01000	0.0 dB	+20.0 dB
01001	-1.5 dB	+18.5 dB
...	...	...
11111	-34.5 dB	-14.5 dB

**Table 3. Microphone Input Gain Values**

#### 4.8 Stereo Analog Mixer Input Gain Registers (Index 10h - 18h)

D15	D14	D13	D12	D11	D10	D9	D8	D7	D6	D5	D4	D3	D2	D1	D0
Mute	0	0	GL4	GL3	GL2	GL1	GL0	0	0	0	GR4	GR3	GR2	GR1	GR0

- Mute** Stereo Input Mute. Setting this bit mutes the respective input signal, both right and left inputs.
- GL[4:0]** Left Volume Control. The GL[4:0] bits are used to control the gain level of the left analog input source to the Input Mixer. Each step corresponds to 1.5 dB gain adjustment, with 01000 = 0 dB. The total range is +12 dB to -34.5 dB gain. See Table 4 for further details.
- GR[4:0]** Right Volume Control. The GR[4:0] bits are used to control the gain level of the right analog input source to the Input Mixer. Each step corresponds to 1.5 dB gain adjustment, with 01000 = 0 dB. The total range is +12 dB to -34.5 dB gain. See Table 4 for further details.
- Default** 8808h. This value corresponds to 0 dB gain and Mute 'set'.

The Stereo Analog Mixer Input Gain Registers are listed in Table 5.

Gx[4:0]	Gain Level
00000	+12.0 dB
00001	+10.5 dB
...	...
00111	+1.5 dB
01000	0.0 dB
01001	-1.5 dB
...	...
11111	-34.5 dB

**Table 4. Analog Mixer Input Gain Values**

Register Index	Function
10h	Line In Volume
12h	CD Volume
14h	Video Volume
16h	Aux Volume
18h	PCM Out Volume

**Table 5. Stereo Volume Register Index**

#### 4.9 Input Mux Select Register (Index 1Ah)

D15	D14	D13	D12	D11	D10	D9	D8	D7	D6	D5	D4	D3	D2	D1	D0
0	0	0	0	0	SL2	SL1	SL0	0	0	0	0	0	SR2	SR1	SR0

- SL[2:0]** Left Channel Source. The SL[2:0] bits select the left channel source to pass to the ADCs for recording. See Table 6 for possible values.
- SR[2:0]** Right Channel Source. The SR[2:0] bits select the right channel source to pass to the ADCs for recording. See Table 6 for possible values.
- Default** 0000h. This value selects the Mic input for both channels.

Sx[2:0]	Record Source
000	Mic
001	CD Input
010	Video Input
011	Aux Input
100	Line Input
101	Stereo Mix
110	Mono Mix
111	Phone Input

**Table 6. Input Mux Selection**

#### 4.10 Record Gain Register (Index 1Ch)

D15	D14	D13	D12	D11	D10	D9	D8	D7	D6	D5	D4	D3	D2	D1	D0
Mute	0	0	0	GL3	GL2	GL1	GL0	0	0	0	0	GR3	GR2	GR1	GR0

- Mute** Record Gain Mute. Setting this bit mutes the input to the L/R ADCs.
- GL[3:0]** Left ADC Gain. The GL[3:0] bits control the input gain on the left channel of the analog source, applied after the input mux and before the ADCs. Each step corresponds to 1.5 dB gain adjustment, with 0000 = 0 dB. The total range is 0 dB to +22.5 dB gain.
- GR[3:0]** Right ADC Gain. The GR[3:0] bits control the input gain on the right channel of the analog source, applied after the input mux and before the ADCs. Each step corresponds to 1.5 dB gain adjustment, with 0000 = 0 dB. The total range is 0 dB to +22.5 dB gain.
- Default** 8000h. This value corresponds to 0 dB gain and Mute 'set'.

#### 4.11 General Purpose Register (Index 20h)

D15	D14	D13	D12	D11	D10	D9	D8	D7	D6	D5	D4	D3	D2	D1	D0
0	0	3D	0	0	0	MIX	MS	LPBK	0	0	0	0	0	0	0

- 3D**                      3D Enable. When 'set', the 3D bit enables the CrystalClear™ 3D stereo enhancement. This function is not available in DAC Direct Mode (DDM).
- MIX**                    Mono Output Select. The MIX bit selects the source for the Mono Out output. When 'set', the microphone input is selected. When 'clear', the stereo-to-mono mixer is selected.
- MS**                     Microphone Select. The MS bit determines which of the two Mic inputs are passed to the mixer. When 'set', the MIC2 input is selected. When 'clear', the MIC1 input is selected.
- LPBK**                 Loopback Enable. When 'set', the LPBK bit enables the ADC/DAC Loopback Mode. This bit routes the output of the ADCs to the input of the DACs without involving the AC-link.
- Default**                0000h

#### 4.12 3D Control Register (Index 22h)

D15	D14	D13	D12	D11	D10	D9	D8	D7	D6	D5	D4	D3	D2	D1	D0
0	0	0	0	0	0	0	0	0	0	0	0	S3	S2	S1	S0

- S[3:0]**                 Spacial Enhancement Depth. These bits control the amount of "space" added to the output stereo signal. When S[3:0] = 0000, the minimum amount of spatial enhancement is added. When S[3:0] = 1111, the maximum amount of spatial enhancement is added. The 3D function is enabled and disabled by the 3D bit in the *General Purpose Register (Index 20h)*.
- Default**                0000h. This value corresponds to minimum spatial enhancement added to the output signal.

### 4.13 Powerdown Control/Status Register (Index 26h)

D15	D14	D13	D12	D11	D10	D9	D8	D7	D6	D5	D4	D3	D2	D1	D0
EAPD	PR6	PR5	PR4	PR3	PR2	PR1	PR0	0	0	0	0	REF	ANL	DAC	ADC

EAPD	External Amplifier Power Down. The EAPD pin follows this bit and is generally used to power down external amplifiers.
PR6	Alternate Line Out Powerdown. When 'set', the alternate line out buffer is powered down.
PR5	Internal Clock Disable. When 'set', this bit completely powers down both the analog and digital sections of the CS4299. The only way to recover from setting this bit is through a Cold Reset (driving the RESET# signal active).
PR4	AC-link Powerdown. When 'set', the AC link is powered down (BIT_CLK off). The AC-link can be restarted through a Warm Reset using the SYNC signal, or a Cold Reset using the RESET# signal (primary audio codec only).
PR3	Analog Mixer Powerdown (Vref off). When 'set', the analog mixer and voltage reference are powered down. When clearing this bit, the ANL, ADC, and DAC bits should be checked before writing any mixer registers.
PR2	Analog Mixer Powerdown (Vref on). When 'set', the analog mixer is powered down (the voltage reference is still active). When clearing this bit, the ANL bit should be checked before writing any mixer registers.
PR1	Front DACs Powerdown. When 'set', the DACs are powered down. When clearing this bit, the DAC bit should be checked before sending any data to the DACs.
PR0	L/R ADCs and Input Mux Powerdown. When 'set', the ADCs and the ADC input muxes are powered down. When clearing this bit, no valid data will be sent down the AC link until the ADC bit goes high.
REF	Voltage Reference Ready Status. When 'set', indicates the voltage reference is at a nominal level.
ANL	Analog Ready Status. When 'set', the analog output mixer, input multiplexer, and volume controls are ready. When clear, no volume control registers should be written.
DAC	Front DAC Ready Status. When 'set', the DACs are ready to receive data across the AC link. When clear, the DACs will not accept any valid data.
ADC	L/R ADC Ready Status. When 'set', the ADCs are ready to send data across the AC link. When clear, no data will be sent to the Controller.
Default	0000h. This value indicates all blocks are powered on. The lower four bits will change as the CS4299 finishes an initialization and calibration sequence.

The PR[6:0] and the EAPD bits are powerdown control for different sections of the CS4299 as well as external amplifiers. The REF, ANL, DAC, and ADC bits are read-only status bits which, when 'set', indicate that a particular section of the CS4299 is ready. After the controller receives the Codec Ready bit in input Slot 0, these status bits must be checked before writing to any mixer registers. See Section 5, *Power Management*, for more information on the powerdown functions.

#### 4.14 Extended Audio ID Register (Index 28h)

D15	D14	D13	D12	D11	D10	D9	D8	D7	D6	D5	D4	D3	D2	D1	D0
ID1	ID0	0	0	0	0	AMAP	0	0	0	0	0	0	0	0	VRA

- ID[1:0]**      Codec Configuration ID. When ID[1:0] = 00, the CS4299 is the primary audio codec. When ID[1:0] = 01, 10, or 11, the CS4299 is a secondary audio codec. The state of the ID[1:0] bits is determined at power-up from the ID[1:0]# pins.
- AMAP**      Audio Slot Mapping. The AMAP bit indicates whether the optional AC '97 2.1 compliant AC-link slot to audio DAC mapping is supported. This bit is a shadow of the AMAP bit in the *AC Mode Control Register (Index 5Eh)*. The PCM playback and capture slots are mapped according to Table 8 on page 30.
- VRA**      Variable Rate PCM Audio. The VRA bit indicates whether variable rate PCM audio is supported. This bit always returns '1', indicating that variable rate PCM audio is available.
- Default**      x201h. Where x is determined by the state of ID[1:0]# input pins. The *Extended Audio ID Register (Index 28h)* is a read only register.

#### 4.15 Extended Audio Status/Control Register (Index 2Ah)

D15	D14	D13	D12	D11	D10	D9	D8	D7	D6	D5	D4	D3	D2	D1	D0
0	0	0	0	0	0	0	0	0	0	0	0	0	0	0	VRA

- VRA**      Enable Variable Rate Audio. When 'set', the VRA bit allows access to the *PCM Front DAC Rate Register (Index 2Ch)* and the *PCM L/R ADC Rate Register (Index 32h)*. The bit must be 'set' in order to use variable PCM playback or capture rates. The VRA bit also serves as a powerdown for the DAC and ADC SRC blocks. Clearing VRA will reset the *PCM Front DAC Rate Register (Index 2Ch)* and the *PCM L/R ADC Rate Register (Index 32h)* to their default values. The SRC data path is flushed and the Slot Request bits for the currently active DAC slots will be fixed at '0'.
- Default**      0000h

#### 4.16 PCM Front DAC Rate Register (Index 2Ch)

<b>D15</b>	<b>D14</b>	<b>D13</b>	<b>D12</b>	<b>D11</b>	<b>D10</b>	<b>D9</b>	<b>D8</b>	<b>D7</b>	<b>D6</b>	<b>D5</b>	<b>D4</b>	<b>D3</b>	<b>D2</b>	<b>D1</b>	<b>D0</b>
SR15	SR14	SR13	SR12	SR11	SR10	SR9	SR8	SR7	SR6	SR5	SR4	SR3	SR2	SR1	SR0

SR[15:0] Front DAC Sample Rate. The SR[15:0] bits can only be written when the VRA bit of the *Extended Audio Status/Control Register (Index 2Ah)* is 'set'. If the VRA bit is 'clear', all writes are ignored and the register reads back BB80h; corresponding to a 48 kHz sample rate. If the VRA bit is 'set', seven standard sample rates are available. If a sample rate written to the register is not directly supported, the attempted value to be written will be decoded according to the ranges indicated in Table 7. All register read transactions will reflect the actual value stored (column 2 in Table 7) and not the one attempted to be written.

Default BB80h. This value corresponds to 48 kHz sample rate..

Sample rate (Hz)	SR[15:0]	SR[15:12] Decode Range
8,000	1F40	0 or 1
11,025	2B11	2
16,000	3E80	3
22,050	5622	4 or 5
32,000	7D00	6 or 7
44,100	AC44	8, 9, or Ah
48,000	BB80	Bh, Ch, Dh, Eh, or Fh

**Table 7. Standard Sample Rates**

#### 4.17 PCM L/R ADC Rate Register (Index 32h)

<b>D15</b>	<b>D14</b>	<b>D13</b>	<b>D12</b>	<b>D11</b>	<b>D10</b>	<b>D9</b>	<b>D8</b>	<b>D7</b>	<b>D6</b>	<b>D5</b>	<b>D4</b>	<b>D3</b>	<b>D2</b>	<b>D1</b>	<b>D0</b>
SR15	SR14	SR13	SR12	SR11	SR10	SR9	SR8	SR7	SR6	SR5	SR4	SR3	SR2	SR1	SR0

SR[15:0] Left/Right ADC Sample Rate. The SR[15:0] bits can only be written when the VRA bit of the *Extended Audio Status/Control Register (Index 2Ah)* is 'set'. If the VRA bit is 'clear', all writes are ignored and the register reads back BB80h; corresponding to a 48 kHz sample rate. If the VRA bit is 'set', seven standard sample rates are available. If a sample rate written to the register is not directly supported, the attempted value to be written will be decoded according to the ranges indicated in Table 7. All register read transactions will reflect the actual value stored (column 2 in Table 7) and not the one attempted to be written.

Default BB80h. This value corresponds to 48 kHz sample rate.

#### 4.18 AC Mode Control Register (Index 5Eh)

D15	D14	D13	D12	D11	D10	D9	D8	D7	D6	D5	D4	D3	D2	D1	D0
0	0	0	0	0	0	0	DDM	AMAP	0	SM1	SM0	0	0	0	0

**DDM** DAC Direct Mode. This bit controls the source to the line and alternate line output drivers. When 'set', the L/R DACs directly drive the line and alternate line outputs by bypassing the audio mixer. When 'cleared', the audio mixer is the source for the line and alternate line outputs.

**AMAP** Audio Slot Mapping. This read/write bit controls whether the CS4299 responds to the Codec ID based slot mapping as outlined in the AC '97 2.1 specification. The bit is shadowed in the *Extended Audio ID Register (Index 28h)*. Refer to Table 8 for the slot mapping configurations.

**SM[1:0]** Slot Map. The SM[1:0] bits define the Slot Mapping for the CS4299 when the AMAP bit is 'cleared'. Refer to Table 8 for the slot mapping configurations.

**Default** 0080h

Slot Assignment Mode	Codec ID		Slot Map		AMAP	Slot Assignments			
	ID1	ID0	SM1	SM0		DAC, SPDIF		ADC	
						L	R	L	R
AMAP Mode 0	0	0	X	X	1	3	4	3	4
AMAP Mode 1	0	1	X	X	1	3	4	3	4
AMAP Mode 2	1	0	X	X	1	7	8	7	8
AMAP Mode 3	1	1	X	X	1	6	9	6	9
Slot Map Mode 0	X	X	0	0	0	3	4	3	4
Slot Map Mode 1	X	X	0	1	0	5	6	5	6
Slot Map Mode 2	X	X	1	0	0	7	8	7	8
Slot Map Mode 3	X	X	1	1	0	9	10	9	10

**Table 8. Slot Mapping**

#### 4.19 Misc. Crystal Control Register (Index 60h)

D15	D14	D13	D12	D11	D10	D9	D8	D7	D6	D5	D4	D3	D2	D1	D0
0	0	0	0	Reserved				0	0	Reserved		0	Reserved		LOSM

**LOSM** Loss of SYNC Mute Enable. The LOSM bit controls the loss of SYNC mute function. If this bit is 'set', the CS4299 will mute all analog outputs for the duration of loss of SYNC. If this bit is 'cleared', the mixer will continue to function normally during loss of SYNC. The CS4299 expects to sample SYNC 'high' for 16 consecutive BIT\_CLK periods and then 'low' for 240 consecutive BIT\_CLK periods, otherwise loss of SYNC becomes true.

**Default** 0023h

#### 4.20 S/PDIF Control Register (Index 68h)

D15	D14	D13	D12	D11	D10	D9	D8	D7	D6	D5	D4	D3	D2	D1	D0
SPEN	Val	0	Fs	L	CC6	CC5	CC4	CC3	CC2	CC1	CC0	Emph	Copy	/Audio	Pro

SPEN	S/PDIF Enable. The SPEN bit enables S/PDIF data transmission on the S/PDIF_OUT pin. The SPEN bit routes the left and right channel data from the AC '97 controller, the digital mixer, or the digital effects engine to the S/PDIF transmitter block. The actual data routed to the S/PDIF block is controlled through the AMAP/SM[1:0] configuration in the <i>AC Mode Control Register (Index 5Eh)</i> .
Val	Validity. The V bit is mapped to the V bit (bit 28) of every <i>sub-frame</i> . If this bit is '0', the signal is suitable for conversion or processing.
Fs	Sample Rate. The Fs bit indicates the sampling rate for the S/PDIF data. The inverse of this bit is mapped to bit 25 of the channel status block. When the Fs bit is 'clear', the sampling frequency is 48 kHz. When 'set', the sampling frequency is 44.1 kHz. The actual rate at which S/PDIF data are being transmitted solely depends on the master clock frequency of the CS4299. The Fs bit is merely an indicator to the S/PDIF receiver.
L	Generation Status. The L bit is mapped to bit 15 of the channel status block. For category codes 001xxxx, 0111xxx and 100xxxx, a value of '0' indicates original material and a value of '1' indicates a copy of original material. For all other category codes the definition of the L bit is reversed.
CC[6:0]	Category Code. The CC[6:0] bits are mapped to bits 8-14 of the channel status block.
Emph	Data Emphasis. The Emph bit is mapped to bit 3 of the channel status block. If the Emph bit is '1', 50/15us filter pre-emphasis is indicated. If the bit is '0', no pre-emphasis is indicated.
Copy	Copyright. The Copy bit is mapped to bit 3 of the channel status block. If the Copy bit is '1' copyright is not asserted and copying is permitted.
/Audio	Audio / Non-Audio. The /Audio bit is mapped to bit 1 of the channel status block. If the /Audio bit is '0', the data transmitted over S/PDIF is assumed to be digital audio. If the /Audio bit is '1', non-audio data is assumed.
Pro	Professional/Consumer. The Pro bit is mapped to bit 0 of the channel status block. If the Pro bit is '0', consumer use of the audio control block is indicated. If the bit is '1', professional use is indicated.
Default	0000h

For a further discussion of the proper use of the channel status bits see application note *AN22: Overview of Digital Audio Interface Data Structures* [3].

#### 4.21 Vendor ID1 Register (Index 7Ch)

<b>D15</b>	<b>D14</b>	<b>D13</b>	<b>D12</b>	<b>D11</b>	<b>D10</b>	<b>D9</b>	<b>D8</b>	<b>D7</b>	<b>D6</b>	<b>D5</b>	<b>D4</b>	<b>D3</b>	<b>D2</b>	<b>D1</b>	<b>D0</b>
F7	F6	F5	F4	F3	F2	F1	F0	S7	S6	S5	S4	S3	S2	S1	S0

F[7:0] First Character of Vendor ID. With a value of F[7:0] = 43h, these bits define the ASCII 'C' character.

S[7:0] Second Character of Vendor ID. With a value of S[7:0] = 52h, these bits define the ASCII 'R' character.

Default 4352h. This register contains read-only data.

#### 4.22 Vendor ID2 Register (Index 7Eh)

<b>D15</b>	<b>D14</b>	<b>D13</b>	<b>D12</b>	<b>D11</b>	<b>D10</b>	<b>D9</b>	<b>D8</b>	<b>D7</b>	<b>D6</b>	<b>D5</b>	<b>D4</b>	<b>D3</b>	<b>D2</b>	<b>D1</b>	<b>D0</b>
T7	T6	T5	T4	T3	T2	T1	T0	0	DID2	DID1	DID0	0	REV2	REV1	REV0

T[7:0] Third Character of Vendor ID. With a value of T[7:0] = 59h, these bits define the ASCII 'Y' character.

DID[2:0] Device ID. With a value of DID[2:0] = 011, these bits specify the audio codec is a CS4299.

REV[2:0] Revision. With a value of REV[2:0] = 001, these bits specify the audio codec revision is 'A'.

Default 593xh. This register contains read-only data.

The two Vendor ID registers provide a means to determine the manufacturer of the AC '97 audio codec. The first three bytes of the Vendor ID registers contain the ASCII code for the first three letters of Crystal (CRY). The final byte of the Vendor ID registers is divided into a Device ID field and a Revision field. Table 9 lists the currently defined Device ID's. Table 10 lists the current revisions of the CS4299.

DID[2:0]	Part Name
000	CS4297
001	CS4297A
010	CS4294/CS4298
011	CS4299
100	CS4201
101	CS4205

**Table 9. Device ID with Corresponding Part Number**

REV[2:0]	Revision
001	A
010	B
011	C
100	D, E, F, G, H
101	K
110	L

**Table 10. Revision Values**

## 5. POWER MANAGEMENT

### 5.1 AC '97 Reset Modes

The CS4299 supports three reset methods, as defined in the AC '97 Specification: *Cold AC '97 Reset*, *Warm AC '97 Reset*, *Register AC '97 Reset*. A Cold Reset results in all AC '97 logic (registers included) initialized to its default state. A Warm Reset leaves the contents of the AC '97 register set unaltered. A Register Reset initializes only the AC '97 registers to their default states.

#### 5.1.1 Cold AC '97 Reset

A Cold Reset is achieved by asserting RESET# for a minimum of 1  $\mu$ s after the power supply rails have stabilized. This is done in accordance with the minimum timing specifications in the *AC '97 Serial Port Timing* section on page 7. Once deasserted, all of the CS4299 registers will be reset to their default power-on states and the BIT\_CLK and SDATA\_IN signals will be reactivated.

#### 5.1.2 Warm AC '97 Reset

A Warm Reset allows the AC-link to be reactivated without losing information in the CS4299 registers. A Warm Reset is required to resume from a D3<sub>hot</sub> state, where the AC-link had been halted yet full power had been maintained. A primary codec Warm Reset is initiated when the SYNC signal is driven high for at least 1  $\mu$ s and then driven low in the absence of the BIT\_CLK clock signal. The BIT\_CLK clock will not restart until at least 2 normal BIT\_CLK clock periods (162.8 ns) after the SYNC signal is deasserted. A Warm Reset of the secondary codec is recognized when the primary codec on the AC-link resumes BIT\_CLK generation. The CS4299 will wait for BIT\_CLK to be stable to restore SDATA\_IN activity and/or S/PDIF transmission on the following frame.

#### 5.1.3 Register AC '97 Reset

The third reset mode provides a Register Reset to the CS4299. This is available only when the CS4299 AC-link is active and the Codec Ready bit is 'set'. The audio (including extended audio) registers (*Index 00h - 38h*) and the vendor specific registers (*Index 5Ah - 7Ah*) are reset to their default states by a write of any value to the *Reset Register (Index 00h)*.

## 5.2 Powerdown Controls

The *Powerdown Control/Status Register (Index 26h)* controls the power management functions. The PR[6:0] bits in this register control the internal powerdown states of the CS4299. Powerdown control is available for individual subsections of the CS4299 by asserting any PRx bit or any combination of PRx bits. Most powerdown states can be resumed by clearing the corresponding PRx bit. Table 11 shows the mapping of the power control bits to the functions they manage.

When PR0 is ‘set’, the L/R ADCs and the Input Mux are shut down and the ADC bit in the *Powerdown Control/Status Register (Index 26h)* is ‘cleared’ indicating the ADCs are no longer in a ready state. The same is true for the DACs, the analog mixers, and the reference voltage (Vrefout). When the PR2 or PR3 bit of the mixer is ‘cleared’, the mixer section will begin a power-on process, and the corresponding powerdown status bit will be ‘set’ when the hardware is ready.

Shutting down the AC-link by ‘setting’ PR4 causes the primary Codec to turn off the BIT\_CLK and drive SDATA\_IN low. It also ignores SYNC and

SDATA\_OUT in their normal capacities. Either a Cold Reset or a Warm Reset is required to restore operation to the CS4299. A Cold Reset will restore all mixer registers to their power-on default values. A Warm Reset will not alter the values of any mixer register, except clearing the PR4 bit in *Powerdown Control/Status Register (Index 26h)*.

The PR5 bit powers down all analog and digital subsections of the device. A Cold Reset is the only way to restore operation to the CS4299 after a PR5 global powerdown.

The CS4299 does not automatically mute any input or output when the powerdown bits are ‘set’. The software driver controlling the AC ’97 device must manage muting the input and output analog signals before putting the part into any power management state. The definition of each PRx bit may affect a single subsection or a combination of subsections within the CS4299. Table 12 on page 35 contains the matrix of subsections affected by the respective PRx function. Table 13 on page 35 shows the different operating power consumptions levels for different powerdown functions.

PR Bit	Function
PR0	L/R ADCs and Input Mux Powerdown
PR1	Front DACs Powerdown
PR2	Analog Mixer Powerdown (Vref on)
PR3	Analog Mixer Powerdown (Vref off)
PR4	AC-link Powerdown (BIT_CLK off)*
PR5	Internal Clock Disable
PR6	Alternate Line Out Powerdown
* Applies only to primary codec	

**Table 11. Powerdown PR Bit Functions**

PR Bit	ADCs	DACs	Mixer	Alternate Line Out	Analog Reference	AC Link	Internal Clock Off
PR0	•						
PR1		•					
PR2		•	•	•			
PR3	•	•	•	•	•		
PR4						•	
PR5	•	•	•	•	•	•	•
PR6				•			

**Table 12. Powerdown PR Function Matrix**

Power State	I <sub>DVdd</sub> (mA) [DVdd=3.3 V]	I <sub>DVdd</sub> (mA) [DVdd=5 V]	I <sub>AVdd</sub> (mA)
Full Power + SRC's	29.1	50.2	37.9
Full Power + S/PDIF <sup>1</sup>	30.1	49.4	37.9
Full Power	24.5	43.4	37.9
ADCs off (PR0)	21.0	38.1	29.0
DACs off (PR1)	22.1	39.6	31.3
Audio off (PR2)	22.1	39.9	10.7
Vref off (PR3)	18.9	34.8	45 μA
AC-Link off (PR4)	19.3	35.5	37.9
Internal Clocks off (PR5)	11 μA	27 μA	45 μA
Alt line out off (PR6)	24.5	43.4	36.2
RESET	11 μA	27 μA	450 μA

**Table 13. Power Consumption by Powerdown Mode**

<sup>1</sup> Assuming standard resistive load for transformer coupled coaxial S/PDIF output (Rload = 292 Ohm, DVdd = 3.3 V) (Rload = 415 Ohm, DVdd = 5 V).  
 General: I<sub>DVdd S/PDIF</sub> = I<sub>DVdd</sub> + DVdd/Rload/2

## 6. ANALOG HARDWARE DESCRIPTION

The analog line-level input hardware consists of four stereo inputs (LINE\_IN\_L/R, CD\_L/GND/R, VIDEO\_L/R, and AUX\_L/R), two selectable mono microphone inputs (MIC1 and MIC2), and two mono inputs (PC\_BEEP and PHONE). The analog line-level output hardware consists of a mono output (MONO\_OUT), and dual stereo line outputs (LINE\_OUT\_L/R and ALT\_LINE\_OUT\_L/R). This section describes the analog hardware needed to interface with these pins. The designs presented in this section comply with specifications detailed in Chapter 17 of the Microsoft® *PC Design Guidelines* [7] (referred to as PC 99). For EMI reduction techniques refer to the application note *NI65: CS4297A/CS4299 EMI Reduction Techniques* [5].

### 6.1 Analog Inputs

All analog inputs to the CS4299, including CD\_GND, should be capacitively coupled to the input pins. Unused analog inputs should be tied together and connected through a capacitor to analog ground or tied to the Vrefout pin directly. The maximum allowed voltage for analog inputs, except the microphone input, is 1 V<sub>RMS</sub>. For the microphone input the maximum allowed voltage depends on the selected boost setting.

#### 6.1.1 Line-Level Inputs

Figure 10 shows circuitry for a line-level stereo input. Replicate this circuit for the Line, Video and Aux inputs. This design attenuates the input by 6 dB, bringing the signal from the PC 99 specified 2 V<sub>RMS</sub>, to the CS4299 maximum allowed 1 V<sub>RMS</sub>.

#### 6.1.2 CD Input

The CD line-level input has an extra pin, CD\_GND, providing a pseudo-differential input for both CD\_L and CD\_R. This pin takes the common-mode noise out of the CD inputs when

connected to the CD analog source ground. Following the reference designs in Figure 11 and Figure 12 provides extra attenuation of common mode noise coming from the CD-ROM drive, thereby producing a higher quality signal. One percent resistors are recommended since closely matched resistor values provide better common-mode attenuation of unwanted signals. The circuit shown in Figure 11 can be used to attenuate a 2 V<sub>RMS</sub> CD input signal by 6 dB. The circuit shown in Figure 12 can be used for a 1 V<sub>RMS</sub> CD input signal.

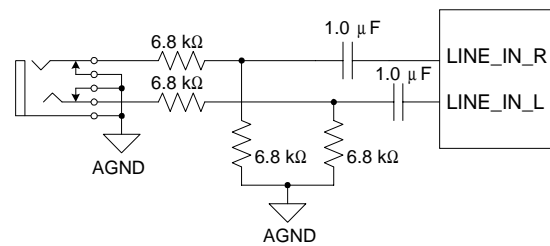

**Figure 10. Line Input (Replicate for Video and Aux)**

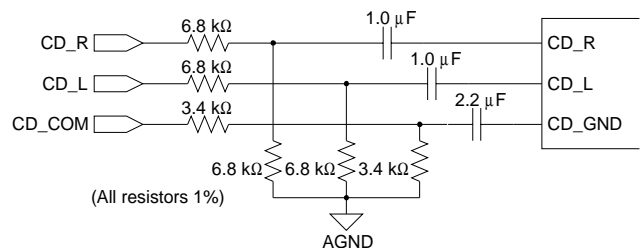

**Figure 11. Differential 2 V<sub>RMS</sub> CD Input**

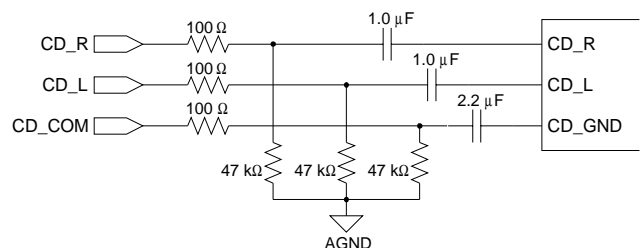

**Figure 12. Differential 1 V<sub>RMS</sub> CD Input**

**6.1.3 Microphone Inputs**

Figure 13 illustrates an input circuit suitable for dynamic and electret microphones. Electret, or phantom-powered, microphones use the right channel (ring) of the jack for power. The design also supports the recommended advanced frequency response for voice recognition as specified in PC 99. Note the microphone input to the CS4299 has an integrated pre-amplifier. Using the 20dB bit in the *Microphone Volume Register (Index 0Eh)* the pre-amplifier gain can be set to 0 dB or 20 dB. Figure 14 shows an external pre-amplifier circuit for an additional 18 dB gain.

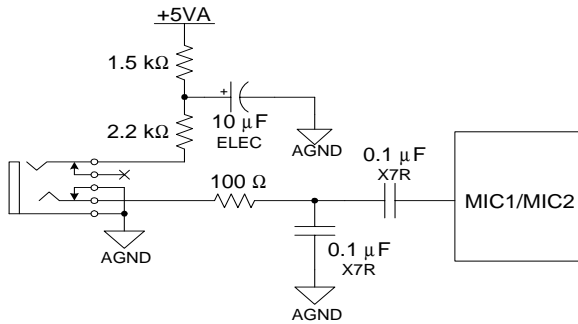

**Figure 13. Microphone Input**

**6.1.4 PC Beep Input**

The PC\_BEEP input is useful for mixing the output of the “beeper” (timer chip), provided in most PCs, with the other audio signals. When the CS4299 is held in reset, PC\_BEEP is passed directly to the line output. This allows the system sounds or “beeps” to be available before the AC ’97 interface has been activated. Figure 15 illustrates a typical input circuit for the PC\_BEEP input. If PC\_BEEP is driven from a CMOS gate, the 4.7 kΩ resistor should be tied to analog ground instead of +5VA. Although this input is described for a low-quality “beeper”, it is of the same high-quality as all other analog inputs and may be used for other purposes.

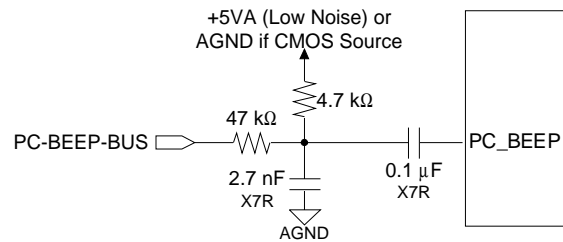

**Figure 15. PC\_BEEP Input**

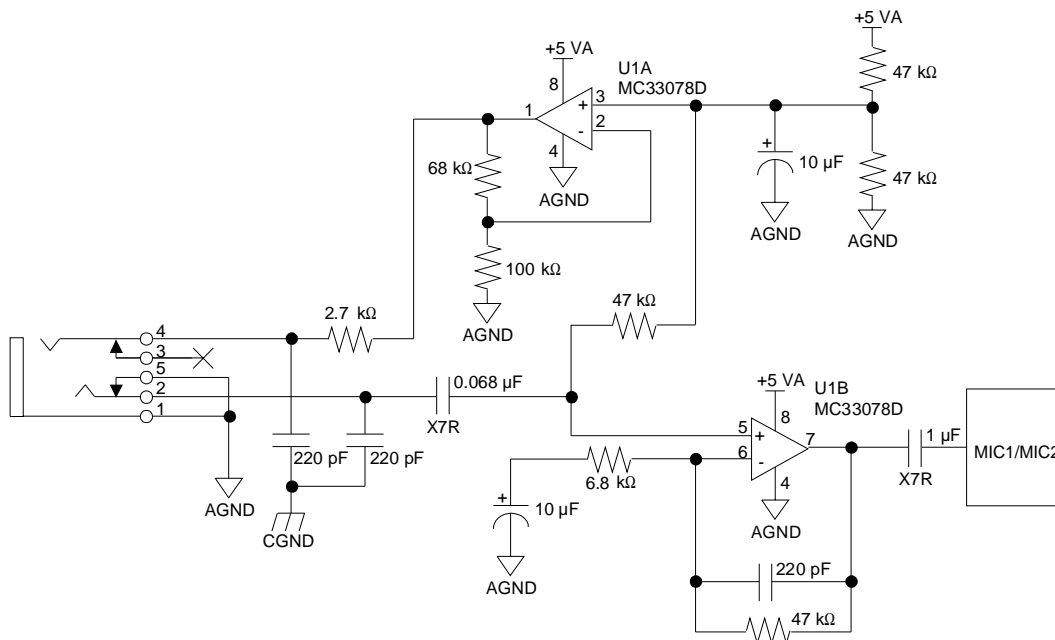

**Figure 14. Microphone Pre-amplifier**

**6.1.5 Phone Input**

One application of the PHONE input is to interface to the output of a modem analog front end (AFE) device so that modem dialing signals and protocol negotiations may be monitored through the audio system. Figure 16 shows a design for a modem connection where the output is fed from the CS4299 MONO\_OUT pin through a divider. The divider ratio shown does not attenuate the signal, providing an output voltage of 1 V<sub>RMS</sub>. If a lower output voltage is desired, the resistors can be replaced with appropriate values, as long as the total load on the output is kept greater than 10 kΩ. The PHONE input is divided by 6 dB to accommodate a line-level source of 2 V<sub>RMS</sub>.

**6.2 Analog Outputs**

The analog line-level output section provides two stereo outputs and a mono output. The LINE\_OUT\_L/R, ALT\_LINE\_OUT\_L/R, and

MONO\_OUT pins require 680 pF to 1000 pF NPO capacitors between the corresponding pin and analog ground. Each analog output is DC-biased up to the Vrefout signal reference, nominally 2.3 V. This requires the outputs be AC-coupled to external circuitry (AC load must be greater than 10 kΩ) or DC coupled to a buffer op-amp biased at Vrefout.

**6.2.1 Stereo Outputs**

See Figure 18 for a line-level stereo output reference design. See Figure 17 for a recommended headphone stereo output reference design.

**6.2.2 Mono Output**

The mono output, MONO\_OUT, can be either a sum of the left and right output channels, attenuated by 6 dB to prevent clipping at full scale, or the selected Mic signal. The mono out channel can drive the PC internal mono speaker using an appropriate buffer circuit

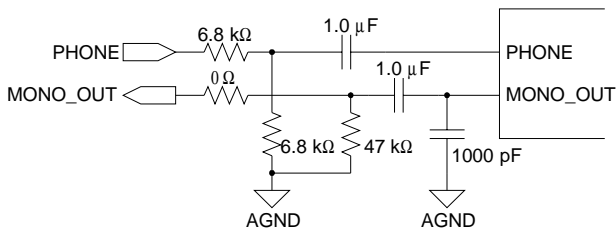

**Figure 16. Modem Connection**

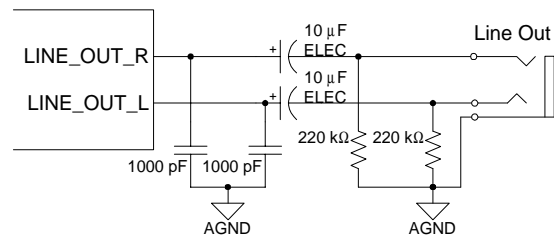

**Figure 18. Stereo Output**

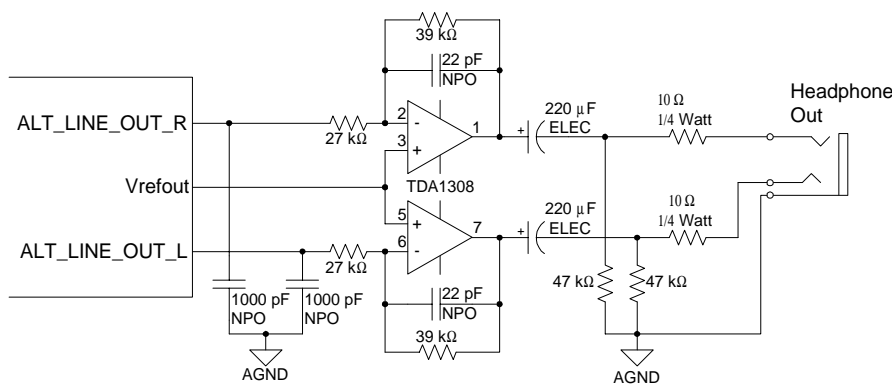

**Figure 17. Alternate Line Output as Headphone Output**

### 6.3 Miscellaneous Analog Signals

The AFLT1 and AFLT2 pins must have a 1000 pF NPO capacitor to analog ground. These capacitors provide a single-pole low-pass filter at the inputs to the ADCs. This makes low-pass filters at each analog input pin unnecessary.

The REFFLT pin must have a 1  $\mu\text{F}$  and a 0.1  $\mu\text{F}$  capacitor connected to analog ground with a short, wide trace to this pin (see Figure 21 in Section 8, *Grounding and Layout*, for an example). The 1  $\mu\text{F}$  capacitor must not be replaced with any value higher than 1  $\mu\text{F}$ . No other connection should be made, as any coupling onto this pin will degrade the analog performance of the CS4299. Likewise, digital signals should be kept away from REFFLT for similar reasons.

The Vrefout pin is typically 2.3 V and provides a common mode signal for single-supply external circuits. Vrefout only supports light DC loads and should be buffered if AC loading is needed. For typical use the Vrefout pin should have a 1  $\mu\text{F}$  and a 0.1  $\mu\text{F}$  capacitor connected to analog ground.

### 6.4 Power Supplies

The power supplies providing analog power should be as clean as possible to minimize coupling into the analog section which could degrade analog performance. The analog power pins, AVdd1 and AVdd2, supply power to all the analog circuitry on the CS4299. The +5 V analog supply should be generated from a linear voltage regulator (7805 type) connected to a +12 V supply. This helps isolate the analog circuitry from noise typically found on +5 V digital supplies. A typical voltage regulator circuit for analog power using a MC78M05CDT +5 V regulator is shown in Figure 19. The digital power pins, DVdd1 and DVdd2, should be connected to the same digital supply as the controller AC-link interface. The digital interface on the CS4299 may operate at either +3.3 V or +5 V and proper connection of these pins will depend on the digital power supply of the controller.

### 6.5 Reference Design

See Section 11 for a CS4299 reference design.

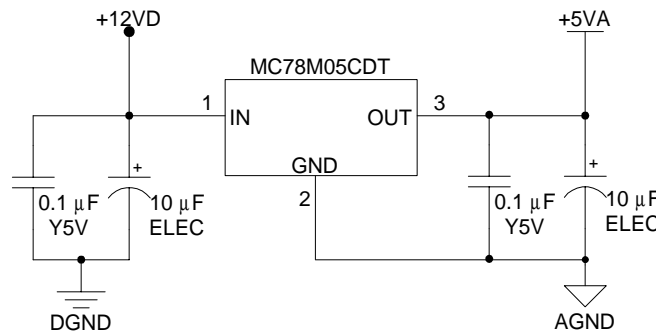

**Figure 19. Voltage Regulator**

## 7. SONY/PHILIPS DIGITAL INTERFACE (S/PDIF)

The S/PDIF digital output is used to interface the CS4299 to consumer audio equipment external to the PC. This output provides an interface for storing digital audio data or playing digital audio data to digital speakers. Figure 20 illustrates the circuits necessary for implementing the IEC-958 optical or consumer interface. For further information on S/PDIF operation see application note *AN22: Overview of Digital Audio Interface Data Structures* [3]. For further information on S/PDIF recommended transformers see application note *AN134: AES and S/PDIF Recommended Transformers* [4].

## 8. GROUNDING AND LAYOUT

Figure 21 on page 41 shows the conceptual layout for the CS4299. The decoupling capacitors should be located physically as close to the pins as possible. Also note the connection of the REFFLT decoupling capacitors to the ground return trace connected directly to the ground return pin, AVss1.

It is strongly recommended that separate analog and digital ground planes be used. Separate ground planes keep digital noise and return currents from modulating the CS4299 ground potential and degrading performance. The digital ground pins should be connected to the digital ground plane and kept separate from the analog ground connections of the CS4299 and any other external analog cir-

cuitry. All analog components and traces should be located over the analog ground plane and all digital components and traces should be located over the digital ground plane.

The common connection point between the two ground planes (required to maintain a common ground voltage potential) should be located under the CS4299. The AC-link digital interface connection traces should be routed such that the digital ground plane lies underneath these signals (on the internal ground layer). This applies along the entire length of these traces from the AC '97 controller to the CS4299.

Refer to the Application Note *AN18: Layout and Design Rules for Data Converters and Other Mixed Signal Devices* [2] for more information on layout and design rules.

### Schematic & Layout Review Service

**Confirm Optimum  
Schematic & Layout  
Before Building Your Board.**

**For Our Free Review Service  
Call Applications Engineering.**

Call: ( 5 1 2 ) 4 4 5 - 7 2 2 2

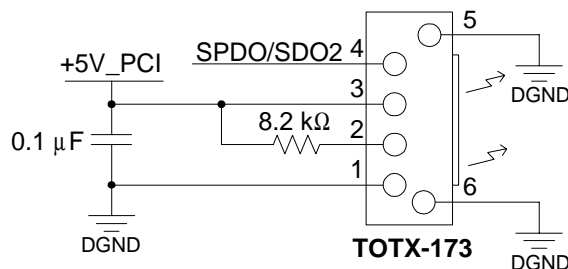
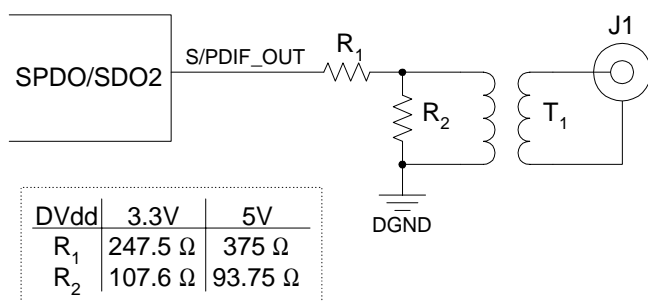

**Figure 20. S/PDIF Output**

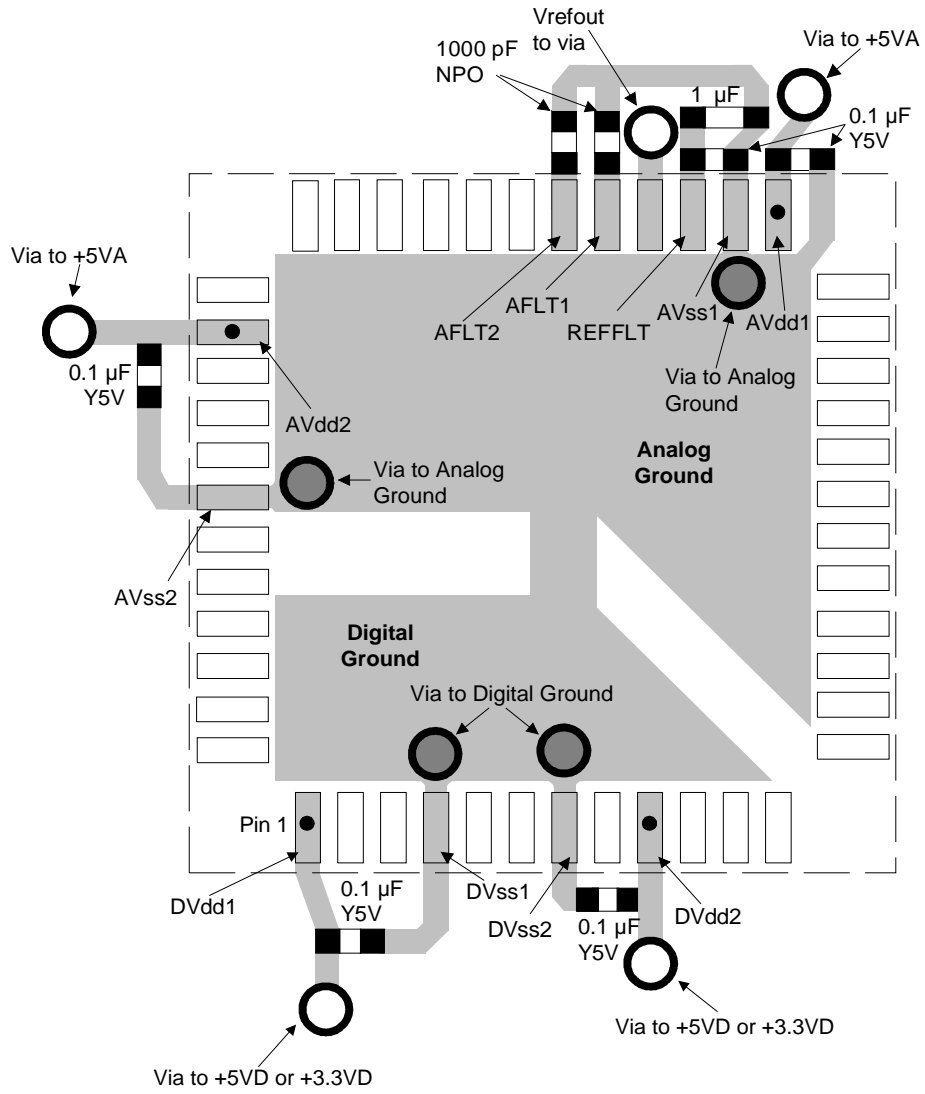

**Figure 21. Conceptual Layout for the CS4299**

**9. PIN DESCRIPTIONS**

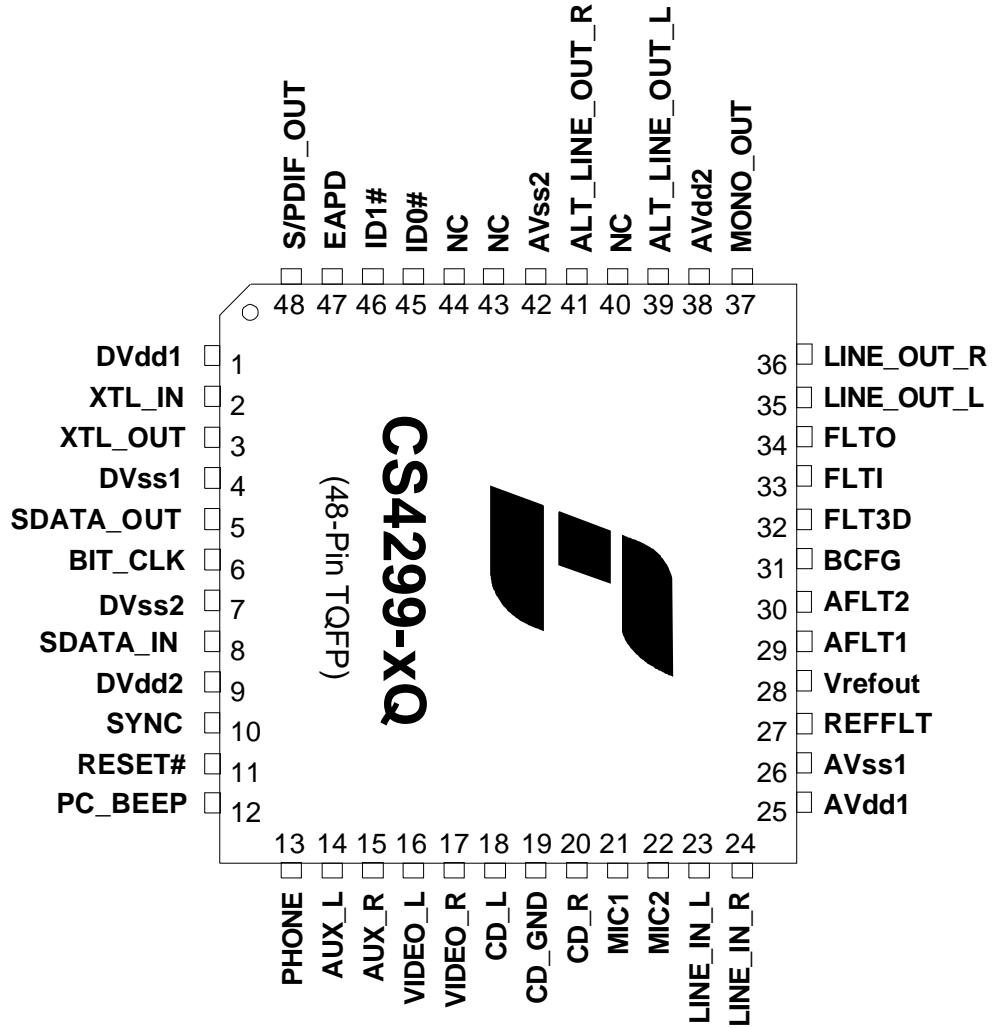

Figure 22. Pin Locations for the CS4299

---

## Audio I/O

### **PC\_BEEP - Analog Mono Source, Input, Pin 12**

The PC\_BEEP input is intended to allow the PC system POST (Power On Self-Test) tones to pass through to the audio subsystem. The PC\_BEEP input has two connections: the first connection is to the analog output mixer, the second connection is directly to the LINE\_OUT stereo outputs. While the RESET# pin is actively being asserted and the BCFG pin is left floating, the PC\_BEEP bypass path to the LINE\_OUT outputs is enabled. While the CS4299 is in normal operation mode, with RESET# deasserted or BCFG grounded, PC\_BEEP is a monophonic source to the analog output mixer. The maximum allowable input is  $1 V_{RMS}$  (sinusoidal). This input is internally biased at the Vrefout voltage reference and requires AC-coupling to external circuitry. If this input is not used, it should be connected to the Vrefout pin or AC-coupled to analog ground.

### **PHONE - Analog Mono Source, Input, Pin 13**

This analog input is a monophonic source to the analog output mixer. It is intended to be used as a modem subsystem input to the audio subsystem. The maximum allowable input is  $1 V_{RMS}$  (sinusoidal). This input is internally biased at the Vrefout voltage reference and requires AC-coupling to external circuitry. If this input is not used, it should be connected to the Vrefout pin or AC-coupled to analog ground.

### **MIC1 - Analog Mono Source, Input, Pin 21**

This analog input is a monophonic source to the analog output mixer. It is intended to be used as a desktop microphone connection to the audio subsystem. The CS4299 internal mixer's microphone input is MUX selectable with either MIC1 or MIC2 as the input. The maximum allowable input is  $1 V_{RMS}$  (sinusoidal). This input is internally biased at the Vrefout voltage reference and requires AC-coupling to external circuitry. If this input is not used, it should be connected to the Vrefout pin or AC-coupled to analog ground.

### **MIC2 - Analog Mono Source, Input, Pin 22**

This analog input is a monophonic source to the analog output mixer. It is intended to be used as an alternate microphone connection to the audio subsystem. The CS4299 internal mixer's microphone input is MUX selectable with either MIC1 or MIC2 as the input. The maximum allowable input is  $1 V_{RMS}$  (sinusoidal). This input is internally biased at the Vrefout voltage reference and requires AC-coupling to external circuitry. If this input is not used, it should be connected to the Vrefout pin or AC-coupled to analog ground.

### **LINE\_IN\_L, LINE\_IN\_R - Analog Line Source, Inputs, Pins 23 and 24**

These inputs form a stereo input pair to the CS4299. The maximum allowable input is  $1 V_{RMS}$  (sinusoidal). These inputs are internally biased at the Vrefout voltage reference and require AC-coupling to external circuitry. If these inputs are not used, they should both be connected to the Vrefout pin or both AC-coupled, with separate AC-coupling caps, to analog ground.

### **CD\_L, CD\_R - Analog CD Source, Inputs, Pins 18 and 20**

These inputs form a stereo input pair to the CS4299. It is intended to be used for the Red Book CD audio connection to the audio subsystem. The maximum allowable input is  $1 V_{RMS}$  (sinusoidal). These inputs are internally biased at the Vrefout voltage reference and require AC-coupling to external circuitry. If these inputs are not used, they should both be connected to the Vrefout pin or both AC-coupled, with separate AC-coupling caps, to analog ground.

### **CD\_GND - Analog CD Common Source, Input, Pin 19**

This analog input is used to remove common mode noise from Red Book CD audio signals. The impedance on the input signal path should be one half the impedance on the CD\_L and CD\_R input paths. This pin requires AC-coupling to external circuitry. If this input is not used, it should be connected to the Vrefout pin or AC-coupled to analog ground.

**VIDEO\_L, VIDEO\_R - Analog Video Audio Source, Inputs, Pins 16 and 17**

These inputs form a stereo input pair to the CS4299. It is intended to be used for the audio signal output of a video device. The maximum allowable input is  $1 V_{RMS}$  (sinusoidal). These inputs are internally biased at the Vrefout voltage reference and require AC-coupling to external circuitry. If these inputs are not used, they should both be connected to the Vrefout pin or both AC-coupled, with separate AC-coupling caps, to analog ground.

**AUX\_L, AUX\_R - Analog Auxiliary Source, Inputs, Pins 14 and 15**

These inputs form a stereo input pair to the CS4299. The maximum allowable input is  $1 V_{RMS}$  (sinusoidal). These inputs are internally biased at the Vrefout voltage reference and require AC-coupling to external circuitry. If these inputs are not used, they should both be connected to the Vrefout pin or both AC-coupled, with separate AC-coupling caps, to analog ground.

**LINE\_OUT\_L, LINE\_OUT\_R - Analog Line-Level, Outputs, Pins 35 and 36**

These signals are analog outputs from the stereo output mixer. The full-scale output voltage for each output is nominally  $1 V_{RMS}$  (sinusoidal). These outputs are internally biased at the Vrefout voltage reference and require either AC-coupling to external circuitry or DC-coupling to a buffer op-amp biased at the Vrefout voltage. These pins need a 680-1000 pF NPO capacitor attached to analog ground.

**ALT\_LINE\_OUT\_L, ALT\_LINE\_OUT\_R - Analog Alternate Line-Level, Outputs, Pins 39 and 41**

These signals are analog outputs from the stereo output mixer. The full-scale output voltage for each output is nominally  $1 V_{RMS}$  (sinusoidal). These outputs are internally biased at the Vrefout voltage reference and require either AC-coupling to external circuitry or DC-coupling to a buffer op-amp biased at the Vrefout voltage. These pins need a 680-1000 pF NPO capacitor attached to analog ground.

**MONO\_OUT - Analog Mono Line-Level, Output, Pin 37**

This signal is an analog output from the stereo-to-mono mixer or MIC1/2. The full-scale output voltage for this output is nominally  $1 V_{RMS}$  (sinusoidal). This output is internally biased at the Vrefout voltage reference and requires either AC-coupling to external circuitry or DC-coupling to a buffer op-amp biased at the Vrefout voltage. This pin needs a 680-1000 pF NPO capacitor attached to analog ground.

*Clock and Configuration***XTL\_IN - Crystal Input/Clock Input, Pin 2**

In primary mode this pin requires either a 24.576 MHz crystal, with the other pin attached to XTL\_OUT, or an external CMOS clock. The crystal frequency must be 24.576 MHz and designed for fundamental mode, parallel resonance operation. If an external CMOS clock is used to drive this pin, it must run at 24.576 MHz. In secondary mode all timing is derived from the BIT\_CLK input signal and this pin should be left floating.

**XTL\_OUT - Crystal Output, Pin 3**

This pin is used when a crystal is placed between XTL\_OUT and XTL\_IN. If an external 24.576 MHz clock is used on XTL\_IN, this pin must be left floating with no traces or components connected to it. In secondary mode this pin should be left floating.

**ID1#, ID0# - Codec ID, Inputs, Pins 45 and 46**

These pins select the Codec ID and mode of operation for the CS4299. They are only sampled after the rising edge of RESET#. These pins are internally pulled up to the digital supply voltage and should be left floating for logic '0' or tied to digital ground for logic '1'. When both pins are left floating the CS4299 is the primary codec. If either or both pins are tied to ground the CS4299 is a secondary codec.

---

### Analog Reference, Filters, and Configuration

#### **REFFLT - Internal Reference Voltage, Input, Pin 27**

This signal is the voltage reference used internal to the CS4299. A 0.1  $\mu$ F and a 1.0  $\mu$ F (must not be larger than 1  $\mu$ F) capacitor with short, wide traces must be connected to this pin. No other connections should be made to this pin.

#### **Vrefout - Voltage Reference, Output, Pin 28**

All analog inputs and outputs are centered around Vrefout, nominally 2.3 Volts. This pin may be used to level shift external circuitry. This pin cannot drive any DC loads, thus any external loading must be buffered.

#### **AFLT1 - Left ADC Channel Antialiasing Filter, Input, Pin 29**

This pin needs a 1000 pF NPO capacitor connected to analog ground.

#### **AFLT2 - Right ADC Channel Antialiasing Filter, Input, Pin 30**

This pin needs a 1000 pF NPO capacitor connected to analog ground.

#### **FLTI, FLTO - 3D Filter, Input, Pin 33 and 34**

A 1000 pF capacitor must be connected between FLTI and FLTO if the 3D function is used.

#### **FLT3D - 3D Filter, Input, Pin 32**

A 0.01  $\mu$ F capacitor must be connected from this pin to AGND if the 3D function is used.

#### **BCFG - Beep Configuration, Input, Pin 31**

This pin is the configuration control for the PC\_BEEP bypass path. If this pin is grounded, the bypass path is disabled. If this pin is left floating, the PC\_BEEP bypass path is enabled.

### Misc. Digital Interfaces

#### **S/PDIF\_OUT - Sony/Philips Digital Interface, Output, Pin 48**

This pin generates the S/PDIF digital output from the CS4299 when the SPEN bit in the *S/PDIF Control Register (Index 68h)* is 'set'. This output may be used to directly drive a resistive divider and coupling transformer to an RCA-type connector for use with consumer audio equipment.

#### **EAPD - External Amplifier Powerdown, Output, Pin 47**

This pin is used to control the powerdown state of an audio amplifier external to the CS4299. The output is controlled by the EAPD bit in the *Powerdown Ctrl/Stat Register (Index 26h)*. It is driven as a normal CMOS output and defaults low ('0') upon power-up.

---

### AC-Link

#### **RESET# - AC '97 Chip Reset, Input, Pin 11**

This active low signal is the asynchronous Cold Reset input to the CS4299. The CS4299 must be reset before it can enter normal operating mode.

#### **SYNC - AC-Link Serial Port Sync pulse, Input, Pin 10**

This signal is the serial port timing signal for the AC-link. Its period is the reciprocal of the maximum sample rate, 48 kHz. The signal is generated by the controller, synchronous to BIT\_CLK. SYNC is an asynchronous input when the CS4299 is configured as a primary audio codec and is in a PR4 powerdown state. A series terminating resistor of 47  $\Omega$  should be connected on the signal near the SYNC source.

#### **BIT\_CLK - AC-Link Serial Port Master Clock, Input/Output, Pin 6**

This input/output signal controls the master clock timing for the AC-link. In primary mode, this signal is a 12.288 MHz output clock derived from a 24.576 MHz crystal on the XTL\_IN input clock. When the CS4299 is in secondary mode, this signal is an input which controls the AC-link serial interface and generates all internal clocking including the AC-link serial interface timing and the analog sampling clocks. A series terminating resistor of 47  $\Omega$  should be connected on this signal close to the CS4299 in primary mode or close to the BIT\_CLK source in secondary mode.

#### **SDATA\_OUT - AC-Link Serial Data Input Stream to AC '97, Input, Pin 5**

This input signal receives the control information and digital audio output streams. The data is clocked into the CS4299 on the falling edge of BIT\_CLK. A series terminating resistor of 47  $\Omega$  should be connected on this signal near the controller.

#### **SDATA\_IN - AC-Link Serial Data Output Stream from AC '97, Output, Pin 8**

This output signal transmits the status information and digital audio input streams from the ADCs. The data is clocked out of the CS4299 on the rising edge of BIT\_CLK. A series terminating resistor of 47  $\Omega$  should be connected on this signal as close to the CS4299 as possible.

### Power Supplies

#### **DVdd1, DVdd2 - Digital Supply Voltage, Pins 1 and 9**

Digital supply voltage for the AC-link section of the CS4299. These pins can be tied to +5 V digital or to +3.3 V digital. The CS4299 and controller AC-link should share a common digital supply

#### **DVss1, DVss2 - Digital Ground, Pins 4 and 7**

Digital ground connection for the AC-link section of the CS4299. These pins should be isolated from analog ground currents.

#### **AVdd1, AVdd2 - Analog Supply Voltage, Pins 25 and 38**

Analog supply voltage for the analog and mixed signal sections of the CS4299. These pins must be tied to the analog +5 V power supply. It is strongly recommended that +5 V be generated from a voltage regulator to ensure proper supply currents and noise immunity from the rest of the system.

#### **AVss1, AVss2 - Analog Ground, Pins 26 and 42**

Ground connection for the analog, mixed signal, and substrate sections of the CS4299. These pins should be isolated from digital ground currents.

---

## 10. PARAMETER AND TERM DEFINITIONS

### AC '97 Specification

Refers to the *Audio Codec '97 Component Specification Ver 2.1* published by the Intel<sup>®</sup> Corporation [6].

### AC '97 Controller or Controller

Refers to the control chip which interfaces to the audio codec AC-link. This has been also called *DC '97* for Digital Controller '97 [6].

### AC '97 Registers or Codec Registers

Refers to the 64-field register map defined in the AC '97 Specification.

### ADC

Refers to a single Analog-to-Digital converter in the CS4299. "ADCs" refers to the stereo pair of Analog-to-Digital converters. The CS4299 ADCs have 18-bit resolution.

### Codec

Refers to the chip containing the ADCs, DACs, and analog mixer. In this data sheet, the codec is the CS4299.

### DAC

Refers to a single Digital-to-Analog converter in the CS4299. "DACs" refers to the stereo pair of Digital-to-Analog converters. The CS4299 DACs have 20-bit resolution.

### dB FS A

dB FS is defined as dB relative to full-scale. The "A" indicates an A weighting filter was used.

### Differential Nonlinearity

The worst case deviation from the ideal code width. Units in LSB.

### Dynamic Range (DR)

DR is the ratio of the RMS full-scale signal level divided by the RMS sum of the noise floor, in the presence of a signal, available at any instant in time (no change in gain settings between measurements). Measured over a 20 Hz to 20 kHz bandwidth with units in dB FS A.

### FFT

Fast Fourier Transform.

### Frequency Response (FR)

FR is the deviation in signal level verses frequency. The 0 dB reference point is 1 kHz. The amplitude corner,  $A_c$ , lists the maximum deviation in amplitude above and below the 1 kHz reference point. The listed minimum and maximum frequencies are guaranteed to be within the  $A_c$  from minimum frequency to maximum frequency inclusive.

### Fs

Sampling Frequency.

### Interchannel Gain Mismatch

For the ADCs, the difference in input voltage to get an equal code on both channels. For the DACs, the difference in output voltages for each channel when both channels are fed the same code. Units are in dB.

**Interchannel Isolation**

The amount of 1 kHz signal present on the output of the grounded AC-coupled line input channel with 1 kHz, 0 dB, signal present on the other line input channel. Units are in dB.

**Line-level**

Refers to a consumer equipment compatible, voltage driven interface. The term implies a low driver impedance and a minimum 10 k $\Omega$  load impedance.

**Paths**

A-D: Analog in, through the ADCs, onto the serial link.

D-A: Serial interface inputs through the DACs to the analog output.

A-A: Analog in to Analog out (analog mixer).

**PC 99**

Refers to the *PC 99 System Design Guide* published by the Microsoft<sup>®</sup> Corporation [7].

**PLL**

Phase Lock Loop. Circuitry for generating a desired clock from an external clock source.

**Resolution**

The number of bits in the output words to the DACs, and in the input words to the ADCs.

**Signal to Noise Ratio (SNR)**

SNR, similar to DR, is the ratio of an arbitrary sinusoidal input signal to the RMS sum of the noise floor, in the presence of a signal. It is measured over a 20 Hz to 20 kHz bandwidth with units in dB.

**S/PDIF**

Sony/Phillips Digital Interface. This interface was established as a means of digitally interconnecting consumer audio equipment. The documentation for S/PDIF has been superseded by the IEC-958 consumer digital interface document.

**SRC**

Sample Rate Converter. Converts data derived at one sample rate to a differing sample rate. The CS4299 operates at a fixed sample frequency of 48 kHz. The internal sample rate converters are used to convert digital audio streams playing back at other frequencies to 48 kHz.

**Total Harmonic Distortion plus Noise (THD+N)**

THD+N is the ratio of the RMS sum of all non-fundamental frequency components, divided by the RMS full-scale signal level. It is tested using a -3 dB FS input signal and is measured over a 20 Hz to 20 kHz bandwidth with units in dB FS.

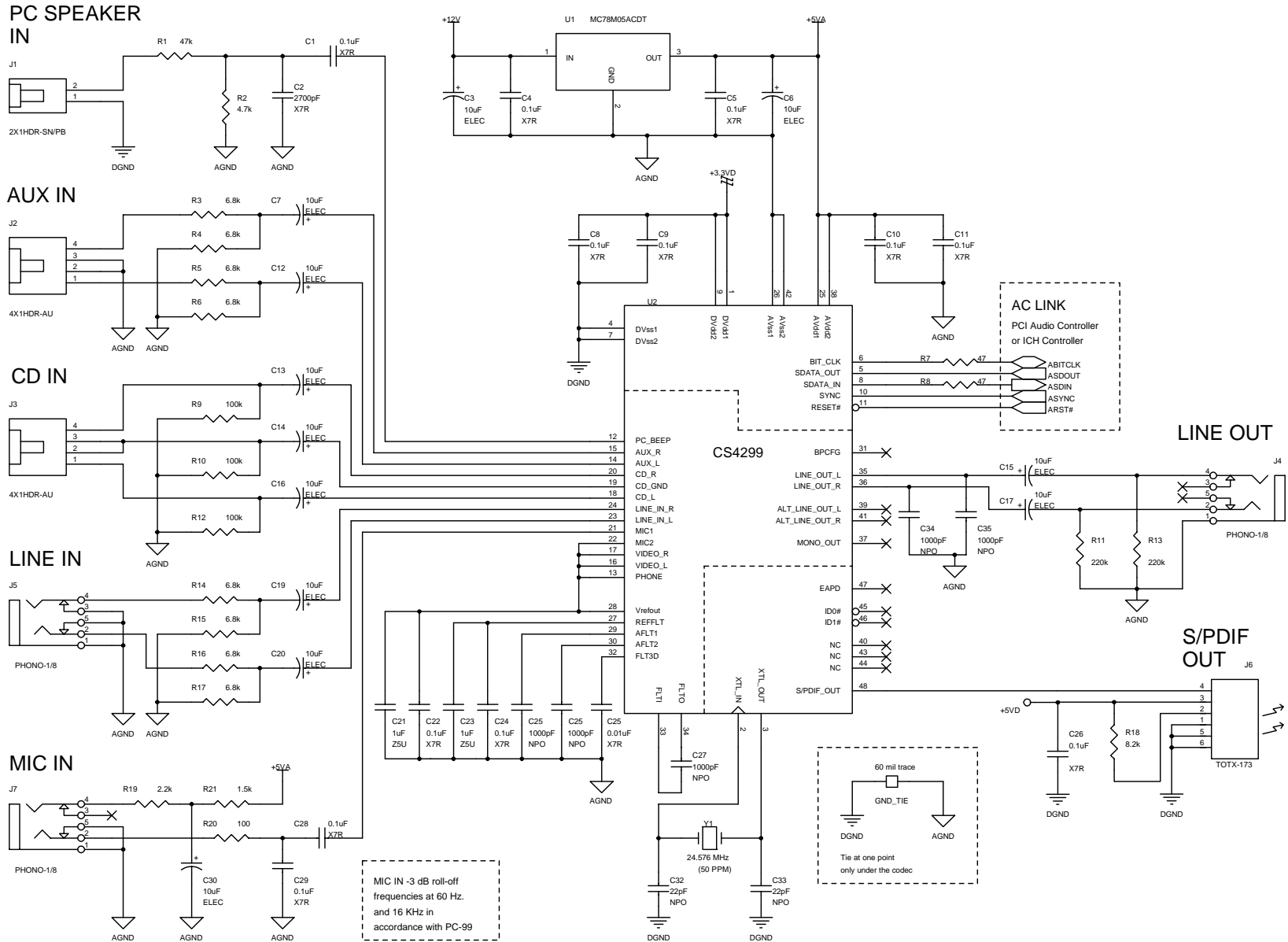

Figure 23. CS4299 Reference Design

**12. REFERENCES**

- 1) Cirrus Logic, Audio Quality Measurement Specification, Version 1.0, 1997  
*<http://www.cirrus.com/products/papers/meas/meas.html>*
- 2) Cirrus Logic, AN18: Layout and Design Rules for Data Converters and Other Mixed Signal Devices, Version 6.0, February 1998
- 3) Cirrus Logic, AN22: Overview of Digital Audio Interface Data Structures, Version 2.0, February 1998
- 4) Cirrus Logic, AN134: AES and S/PDIF Recommended Transformers, Version 2, April 1999
- 5) Cirrus Logic, AN165: CS4297A/CS4299 EMI Reduction Techniques, Version 1.0, September 1999
- 6) Intel<sup>®</sup>, Audio Codec '97 Component Specification, Revision 2.1, May 1998  
*<http://developer.intel.com/ial/scalableplatforms/audio/index.htm>*
- 7) Microsoft<sup>®</sup>, PC 99 System Design Guide, Version 1.0, July 1999  
*<http://www.microsoft.com/hwdev/desguid/>*
- 8) Intel<sup>®</sup>, 82801AA (ICH) and 82801AB (ICH0) I/O Controller Hub, June 1999  
*<http://developer.intel.com/design/chipsets/datashts/290655.htm>*

13. PACKAGE DIMENSIONS

48L LQFP PACKAGE DRAWING

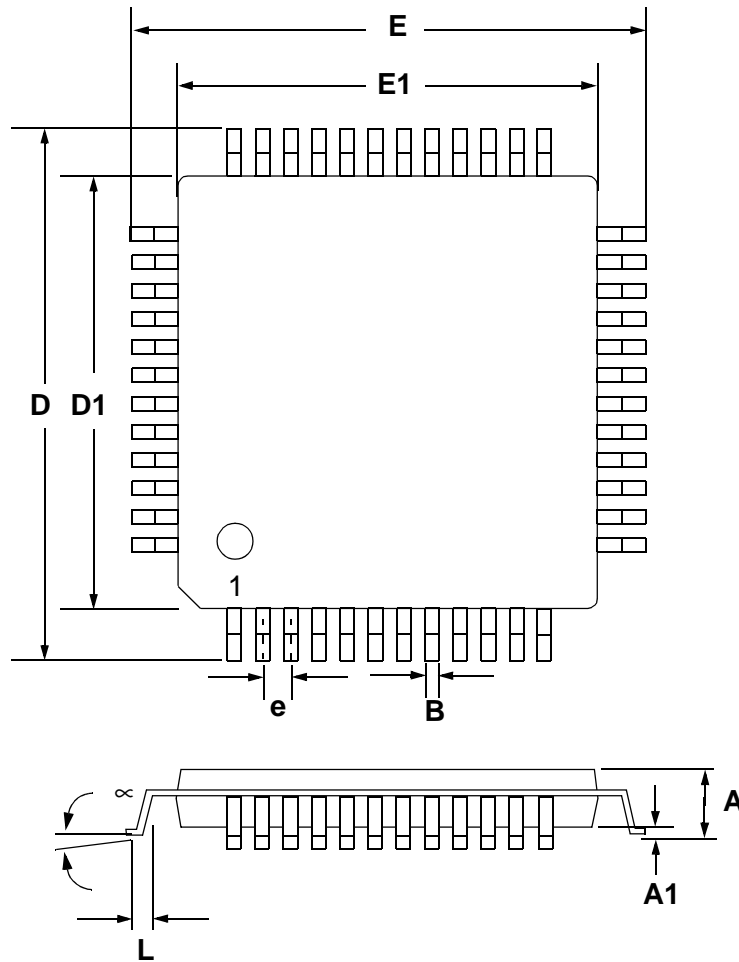

DIM	INCHES			MILLIMETERS		
	MIN	NOM	MAX	MIN	NOM	MAX
A	---	0.055	0.063	---	1.40	1.60
A1	0.002	0.004	0.006	0.05	0.10	0.15
B	0.007	0.009	0.011	0.17	0.22	0.27
D	0.343	0.354	0.366	8.70	9.0 BSC	9.30
D1	0.272	0.28	0.280	6.90	7.0 BSC	7.10
E	0.343	0.354	0.366	8.70	9.0 BSC	9.30
E1	0.272	0.28	0.280	6.90	7.0 BSC	7.10
e*	0.016	0.020	0.024	0.40	0.50 BSC	0.60
L	0.018	0.24	0.030	0.45	0.60	0.75
∞	0.000°	4°	7.000°	0.00°	4°	7.00°

\* Nominal pin pitch is 0.50 mm

Controlling dimension is mm.  
JEDEC Designation: MS022

SMART  
Analog™



LittleDiode supplies new, hard to find or obsolete electronic components and semiconductors all over the world.

With over two million different components listed you are sure to find the part you need.

Feel free to visit us today at our online store:

[LittleDiode.com](http://LittleDiode.com)

Looking forward to providing you with the best possible service.