



1A Adjustable Linear Regulator

Description

The CS5201-1 linear regulator provides 1A with an output voltage accuracy of $\pm 1\%$. The device uses two external resistors to set the output voltage within a 1.25V to 5.5V range.

This regulator is intended for use as a post regulator and microprocessor supply. The fast loop response and low dropout voltage make this regulator ideal for applications where low voltage operation and good transient response are important.

The circuit is designed to operate with dropout voltages less than 1.2V at 1A output current. Device protection includes over-current and thermal shutdown.

The CS5201 is pin compatible with the LT1086 family of linear regulators.

The regulator is available in TO-220, surface mount D², and SOT-223 packages.

Features

- Output Current to 1A
- Output Accuracy to $\pm 1\%$ over Temperature
- Dropout Voltage (typical) 1.0V @ 1A
- Fast Transient Response
- Fault Protection
 - Current Limit
 - Thermal Shutdown

Application Diagram

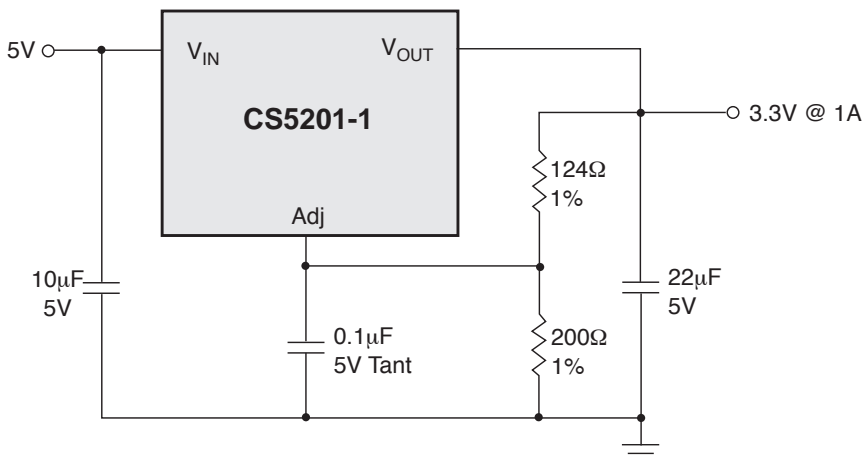

Package Options

3L TO-220
Tab (V_{OUT})

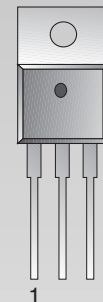

3L D²PAK
Tab (V_{OUT})

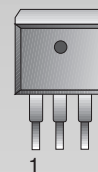

3L SOT-223
Tab (V_{OUT})

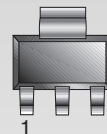

- CS5201 -1
- 1 Adj
 - 2 V_{OUT}(Tab)
 - 3 V_{IN}

Consult factory for fixed output voltage versions.



Absolute Maximum Ratings

Supply Voltage, V_{CC}7V
Operating Temperature Range	-40°C to 70°C
Junction Temperature	150°C
Storage Temperature Range	-60°C to 150°C
Lead Temperature Soldering	
Wave Solder (through hole styles only)10 sec. max, 260°C peak
Reflow (SMD styles only)60 sec. max above 183°C, 230°C peak
ESD Damage Threshold (Human Body Model)2kV

Electrical Characteristics: $C_{IN} = 10\mu\text{F}$, $C_{OUT} = 22\mu\text{F}$ Tantalum, $V_{OUT} + V_{DROPOUT} < V_{IN} < 7\text{V}$, $0^\circ\text{C} \leq T_A \leq 70^\circ\text{C}$, $T_J \leq +150^\circ\text{C}$, unless otherwise specified, $I_{full\ load} = 1\text{A}$.

PARAMETER	TEST CONDITIONS	MIN	TYP	MAX	UNIT
■ Adjustable Output Voltage					
Reference Voltage (Notes 1 and 2)	$V_{IN}-V_{OUT}=1.5\text{V}$; $V_{Adj} = 0\text{V}$ $10\text{mA} \leq I_{OUT} \leq 1\text{A}$	1.241 (-1%)	1.254	1.266 (+1%)	V
Line Regulation	$1.5\text{V} \leq V_{IN}-V_{OUT} \leq 5.75\text{V}$; $I_{OUT}=10\text{mA}$		0.02	0.20	%
Load Regulation (Notes 1 and 2)	$V_{IN}-V_{OUT}=1.5\text{V}$; $10\text{mA} \leq I_{OUT} \leq 1\text{A}$		0.04	0.4	%
Dropout Voltage (Note 3)	$I_{OUT}=1\text{A}$		1.0	1.2	V
Current Limit	$V_{IN}-V_{OUT}=3\text{V}$; $T_J \geq 25^\circ\text{C}$	1.1	3.1		A
Minimum Load Current (Note 4)	$V_{IN}=7\text{V}$; $V_{Adj}=0$		0.6	2.0	mA
Adjust Pin Current	$V_{IN}-V_{OUT}=3\text{V}$; $I_{OUT}=10\text{mA}$		50	100	μA
Thermal Regulation (Note 5)	30ms pulse; $T_A=25^\circ\text{C}$		0.002	0.020	%/W
Ripple Rejection (Note 5)	$f=120\text{Hz}$; $I_{OUT}=1\text{A}$; $V_{IN}-V_{OUT}=3\text{V}$; $V_{RIPPLE}=1\text{V}_{PP}$		80		dB
Thermal Shutdown (Note 6)		150	180	210	$^\circ\text{C}$
Thermal Shutdown Hysteresis (Note 6)			25		$^\circ\text{C}$

Note 1: Load regulation and output voltage are measured at a constant junction temperature by low duty cycle pulse testing. Changes in output voltage due to temperature changes must be taken into account separately.

Note 2: Specifications apply for an external Kelvin sense connection at a point on the output pin 1/4" from the bottom of the package.

Note 3: Dropout voltage is a measurement of the minimum input/output differential at full load.

Note 4: The minimum load current is the minimum current required to maintain regulation. Normally the current in the resistor divider used to set the output voltage is selected to meet the minimum load requirement.

Note 5: Guaranteed by design, not 100% tested in production.

Note 6: Thermal shutdown is 100% functionally tested in production.

Package Pin Description

PACKAGE PIN #			PIN SYMBOL	FUNCTION
D ² PAK	TO-220	SOT-223		
1	1	1	Adj	Adjust pin (low side of the internal reference).
2	2	2	V_{OUT}	Regulated output voltage (case).
3	3	3	V_{IN}	Input voltage.

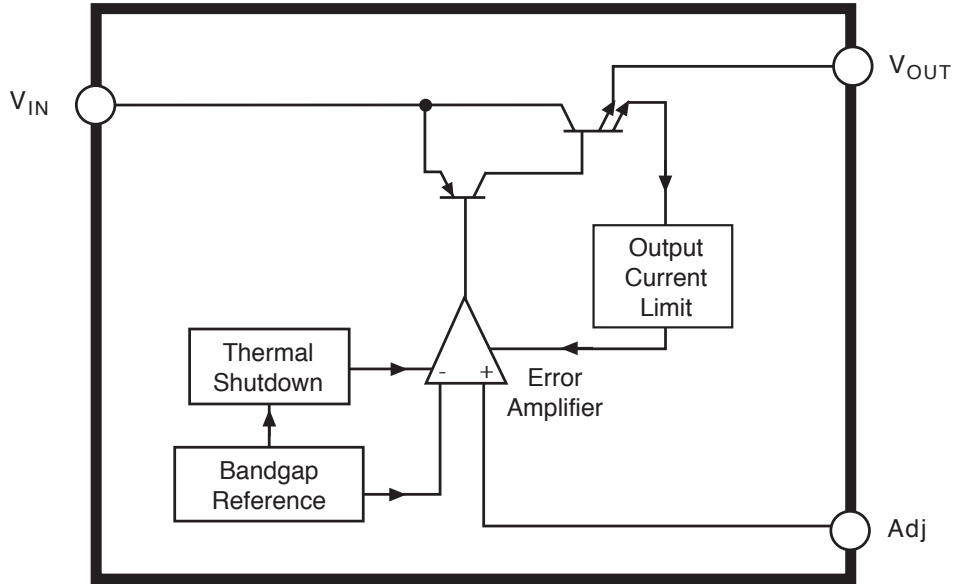

Typical Performance Characteristics

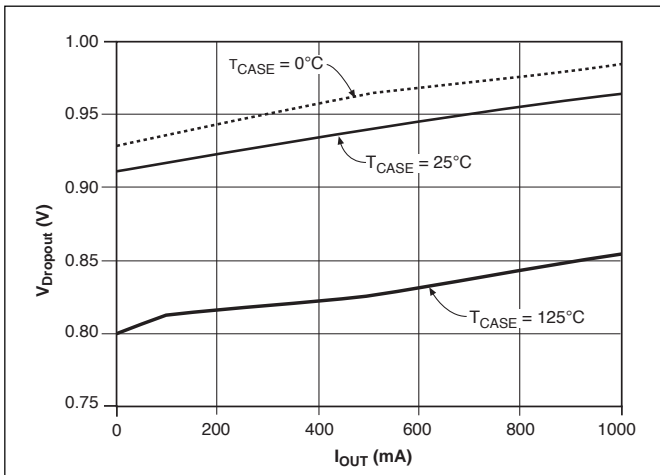

Dropout Voltage vs. Output Current

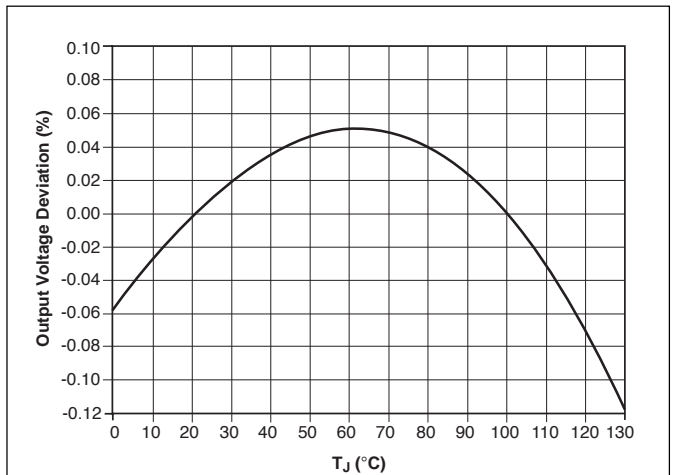

Reference Voltage vs. Temperature

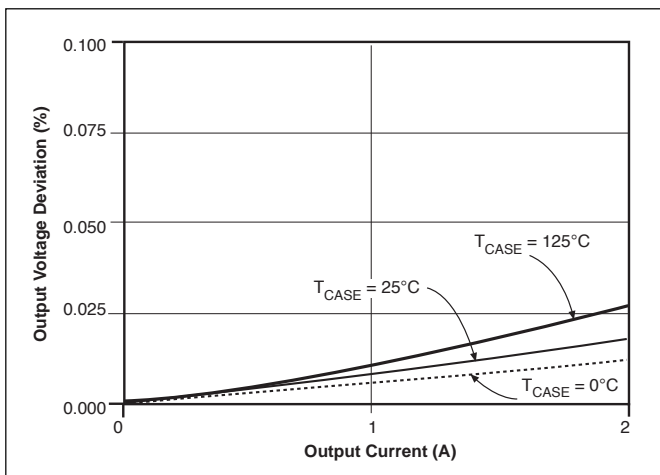

Load Regulation vs. Output Current

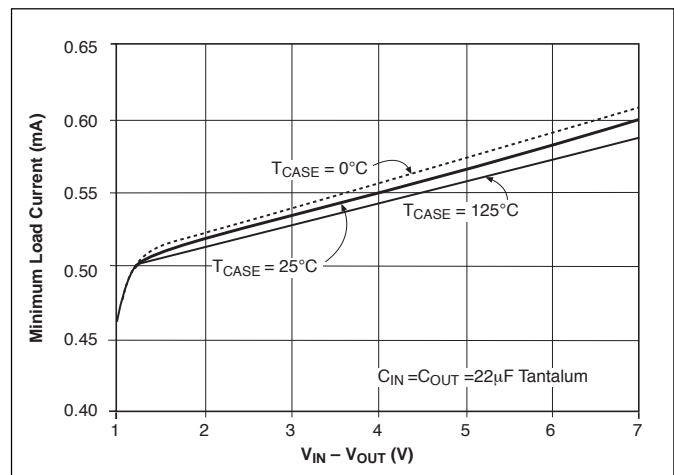

Minimum Load Current vs $V_{IN} - V_{OUT}$

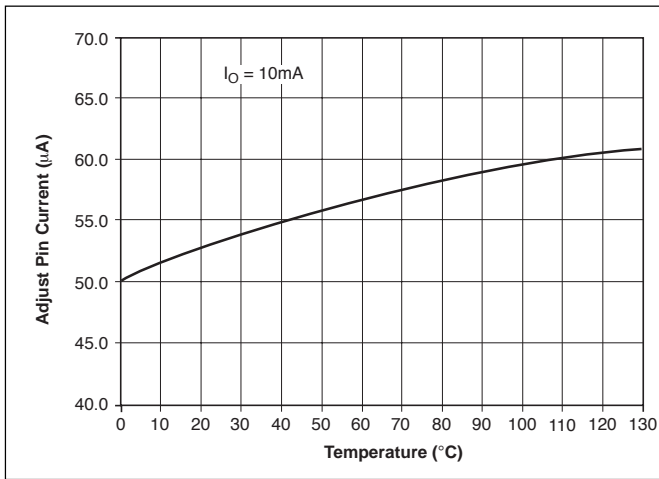

Adjust Pin Current vs. Temperature

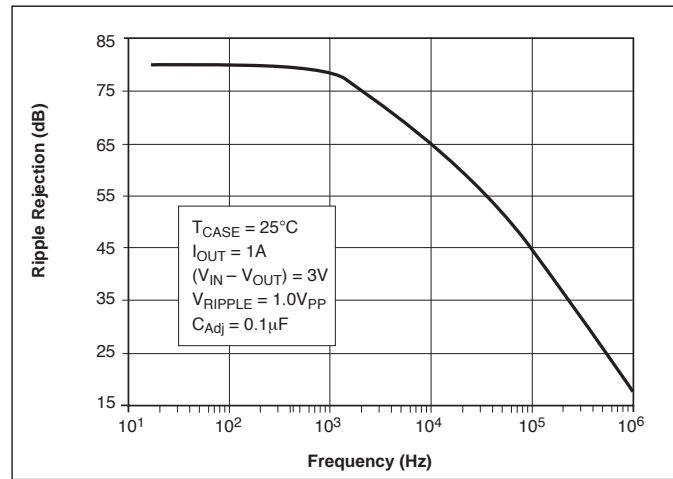

Ripple Rejection vs. Frequency

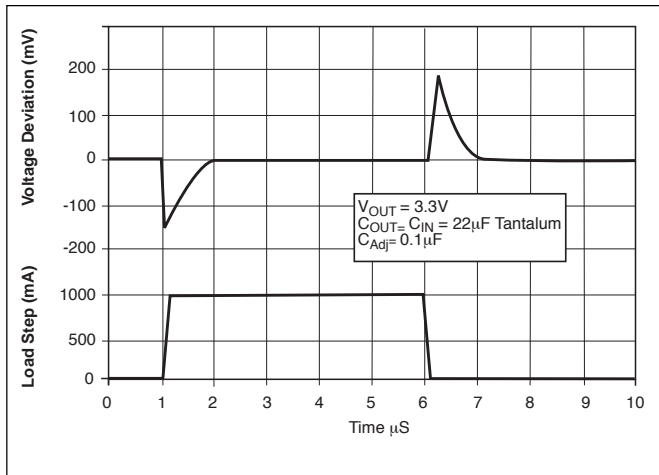

Transient Response

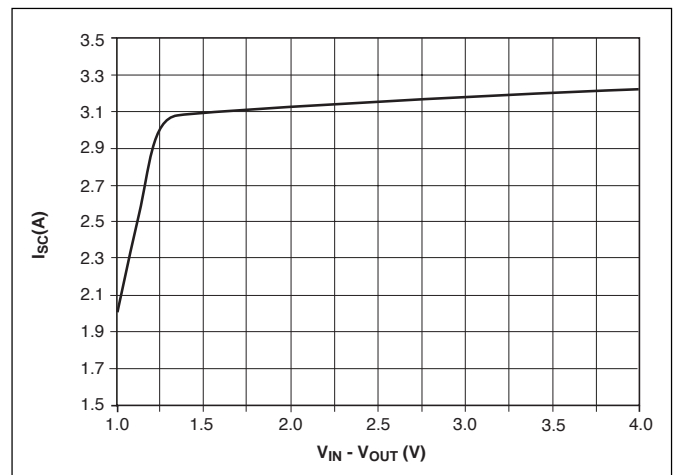
Short Circuit Current vs. $V_{IN} - V_{OUT}$

Applications Information

The CS5201-1 linear regulator provides adjustable voltages at currents up to 1A. The regulator is protected against overcurrent conditions and includes thermal shutdown.

The CS5201-1 has a composite PNP-NPN output transistor and requires an output capacitor for stability. A detailed procedure for selecting this capacitor is included in the Stability Considerations section.

Adjustable Operation

The CS5201-1 has an output voltage range of 1.25V to 5.5V. An external resistor divider sets the output voltage as shown in Figure 1. The regulator maintains a fixed 1.25V (typical) reference between the output pin and the adjust pin.

A resistor divider network R1 and R2 causes a fixed current to flow to ground. This current creates a voltage across R2 that adds to the 1.25V across R1 and sets the overall output voltage. The adjust pin current (typically

50µA) also flows through R2 and adds a small error that should be taken into account if precise adjustment of V_{OUT} is necessary.

The output voltage is set according to the formula:

$$V_{OUT} = V_{REF} \times \left(\frac{R1 + R2}{R1} \right) + I_{Adj} \times R2$$

The term $I_{Adj} \times R2$ represents the error added by the adjust pin current.

$R1$ is chosen so that the minimum load current is at least 2mA. R1 and R2 should be the same type, e.g. metal film for best tracking over temperature. While not required, a bypass capacitor from the adjust pin to ground will improve ripple rejection and transient response. A 0.1µF tantalum capacitor is recommended for "first cut" design. Type and value may be varied to obtain optimum performance vs. price.

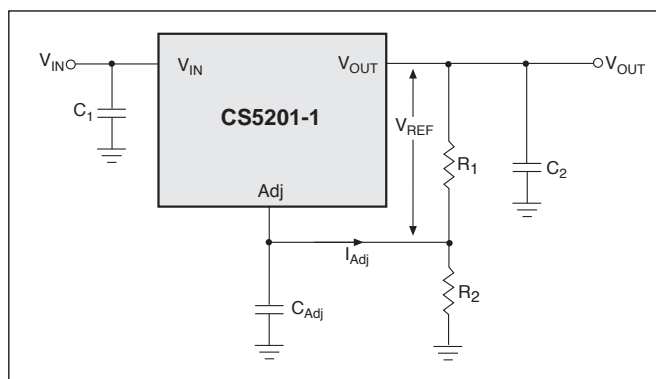

Figure 1. Resistor divider scheme.

Short Circuit Protection

The CS5201-1 linear regulator has an absolute maximum specification of 7V for the voltage difference between V_{IN} and V_{OUT} . However, the IC may be used to regulate voltages in excess of 7V. The main considerations in such a design are power-up and short circuit capability.

In most applications, ramp-up of the power supply to V_{IN} is fairly slow, typically on the order of several tens of milliseconds, while the regulator responds in less than one microsecond. In this case, the linear regulator begins charging the load as soon as the V_{IN} to V_{OUT} differential is large enough that the pass transistor conducts current. The load at this point is essentially at ground, and the supply voltage is on the order of several hundred millivolts, with the result that the pass transistor is in dropout. As the supply to V_{IN} increases, the pass transistor will remain in dropout, and current is passed to the load until V_{OUT} reaches the point at which the IC is in regulation. Further increase in the supply voltage brings the pass transistor out of dropout. The result is that the output voltage follows the power supply ramp-up, staying in dropout until the regulation point is reached. In this manner, any output voltage may be regulated. There is no theoretical limit to the regulated voltage as long as the V_{IN} to V_{OUT} differential of 7V is not exceeded.

However, the possibility of destroying the IC in a short circuit condition is very real for this type of design. Short circuit conditions will result in the immediate operation of the pass transistor outside of its safe operating area. Over-voltage stresses will then cause destruction of the pass transistor before overcurrent or thermal shutdown circuitry can become active. Additional circuitry may be required to clamp the V_{IN} to V_{OUT} differential to less than 7V if fail-safe operation is required. One possible clamp circuit is illustrated in figure 2; however, the design of clamp circuitry must be done on an application by application basis. Care must be taken to ensure the clamp actually protects the design. Components used in the clamp design must be able to withstand the short circuit condition indefinitely while protecting the IC.

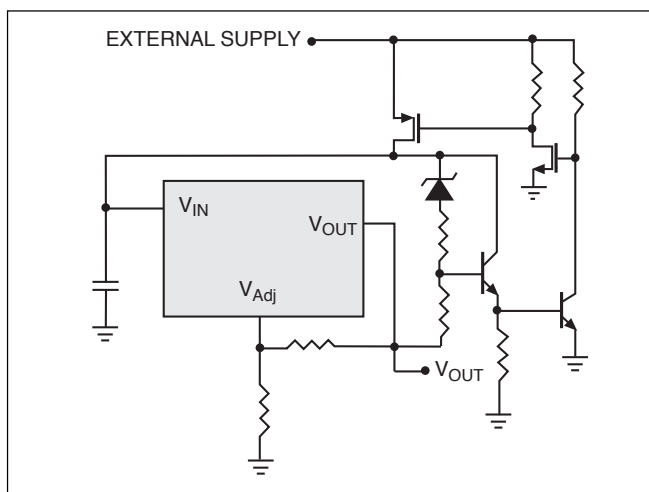

Figure 2. Short Circuit Protection Circuit for High Voltage Application.

Stability Considerations

The output or compensation capacitor helps determine three main characteristics of a linear regulator: start-up delay, load transient response and loop stability.

The capacitor value and type is based on cost, availability, size and temperature constraints. A tantalum or aluminum electrolytic capacitor is best, since a film or ceramic capacitor with almost zero ESR can cause instability. The aluminum electrolytic capacitor is the least expensive solution. However, when the circuit operates at low temperatures, both the value and ESR of the capacitor will vary considerably. The capacitor manufacturers' data sheet provides this information.

A 22 μ F tantalum capacitor will work for most applications, but with high current regulators such as the CS5201 the transient response and stability improve with higher values of capacitance. The majority of applications for this regulator involve large changes in load current so the output capacitor must supply the instantaneous load current. The ESR of the output capacitor causes an immediate drop in output voltage given by:

$$\Delta V = \Delta I \times \text{ESR}$$

For microprocessor applications it is customary to use an output capacitor network consisting of several tantalum and ceramic capacitors in parallel. This reduces the overall ESR and reduces the instantaneous output voltage drop under load transient conditions. The output capacitor network should be as close as possible to the load for the best results.

Protection Diodes

When large external capacitors are used with a linear regulator it is sometimes necessary to add protection diodes. If the input voltage of the regulator gets shorted, the output capacitor will discharge into the output of the regulator. The discharge current depends on the value of the capacitor, the output voltage and the rate at which V_{IN} drops. In the CS5201-1 linear regulator, the discharge path is through a large junction and protection diodes are not usually needed. If the regulator is used with large values of output capacitance and the input voltage is instantaneously shorted to ground, damage can occur. In this case, a diode connected as shown in Figure 3 is recommended.

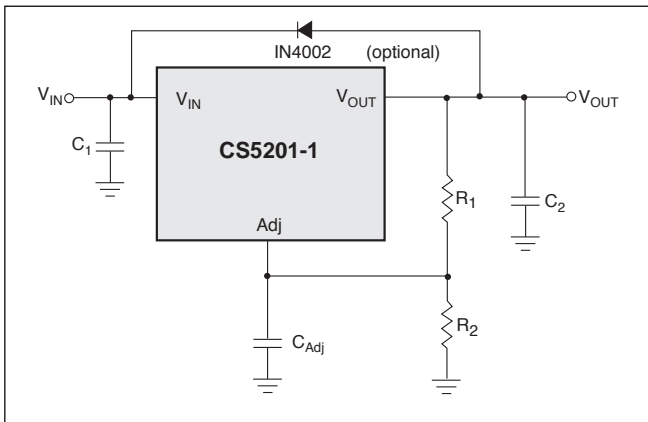

Figure 3. Protection diode for large output capacitors.

Output Voltage Sensing

Since the CS5201-1 is a three terminal regulator, it is not possible to provide true remote load sensing. Load regulation is limited by the resistance of the conductors connecting the regulator to the load.

For the adjustable regulator, the best load regulation occurs when R1 is connected directly to the output pin of the regulator as shown in Figure 4. If R1 is connected to the load, R_C is multiplied by the divider ratio and the effective resistance between the regulator and the load becomes

$$R_C \times \left(\frac{R_1 + R_2}{R_1} \right)$$

R_C = conductor parasitic resistance

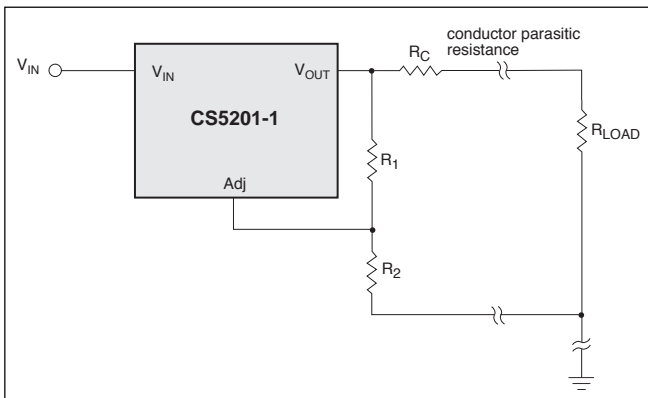

Figure 4. Grounding scheme for the adjustable output regulator to minimize parasitic resistance effects.

Calculating Power Dissipation and Heat Sink Requirements

The CS5201-1 linear regulator includes thermal shutdown and current limit circuitry to protect the device. High power regulators such as these usually operate at high junction temperatures so it is important to calculate the power dissipation and junction temperatures accurately to ensure that an adequate heat sink is used.

The case is connected to V_{OUT} on the CS5201-1, and electrical isolation may be required for some applications. Thermal compound should always be used with high current regulators such as these.

The thermal characteristics of an IC depend on the following four factors:

1. Maximum Ambient Temperature T_A (°C)
2. Power dissipation P_D (Watts)
3. Maximum junction temperature T_J (°C)
4. Thermal resistance junction to ambient R_{θJA} (C/W)

These four are related by the equation

$$T_J = T_A + P_D \times R_{\theta JA} \quad (1)$$

The maximum ambient temperature and the power dissipation are determined by the design while the maximum junction temperature and the thermal resistance depend on the manufacturer and the package type.

The maximum power dissipation for a regulator is:

$$P_{D(max)} = \{V_{IN(max)} - V_{OUT(min)}\} I_{OUT(max)} + V_{IN(max)} I_Q \quad (2)$$

where

V_{IN(max)} is the maximum input voltage,

V_{OUT(min)} is the minimum output voltage,

I_{OUT(max)} is the maximum output current, for the application

I_Q is the maximum quiescent current at I_{OUT(max)}.

A heat sink effectively increases the surface area of the package to improve the flow of heat away from the IC and into the surrounding air.

Each material in the heat flow path between the IC and the outside environment has a thermal resistance. Like series electrical resistances, these resistances are summed to determine R_{θJA}, the total thermal resistance between the junction and the surrounding air.

1. Thermal Resistance of the junction to case, R_{θJC} (°C/W)
2. Thermal Resistance of the case to Heat Sink, R_{θCS} (°C/W)
3. Thermal Resistance of the Heat Sink to the ambient air, R_{θSA} (°C/W)

These are connected by the equation:

$$R_{\theta JA} = R_{\theta JC} + R_{\theta CS} + R_{\theta SA} \quad (3)$$

The value for R_{θJA} is calculated using equation (3) and the result can be substituted in equation (1).

The value for R_{θJC} is 3.5°C/W for a given package type based on an average die size. For a high current regulator such as the CS5201-1 the majority of the heat is generated in the power transistor section. The value for R_{θSA} depends on the heat sink type, while R_{θCS} depends on factors such as package type, heat sink interface (is an insulator and thermal grease used?), and the contact area between the heat sink and the package. Once these calculations are complete, the maximum permissible value of R_{θJA} can be calculated and the proper heat sink selected. For further discussion on heat sink selection, see application note "Thermal Management for Linear Regulators."

PACKAGE DIMENSIONS IN mm (INCHES)

3 Lead TO-220 (T) Straight

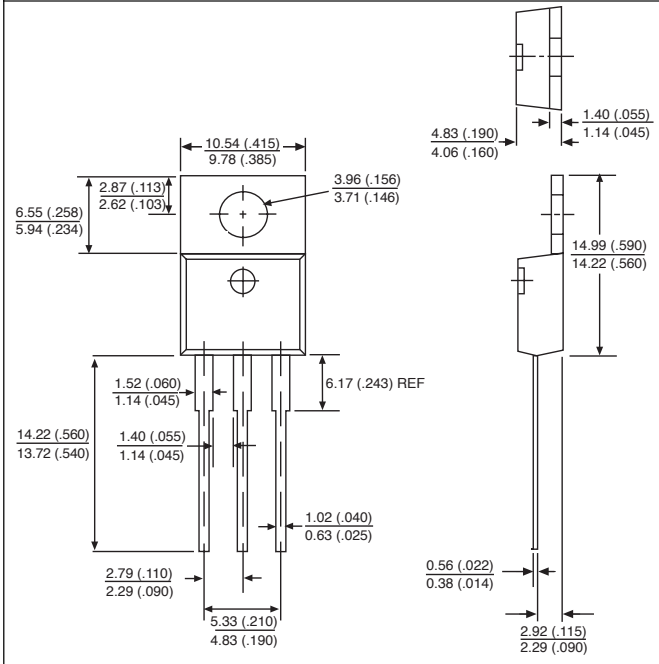

3 Lead D²PAK (DP)

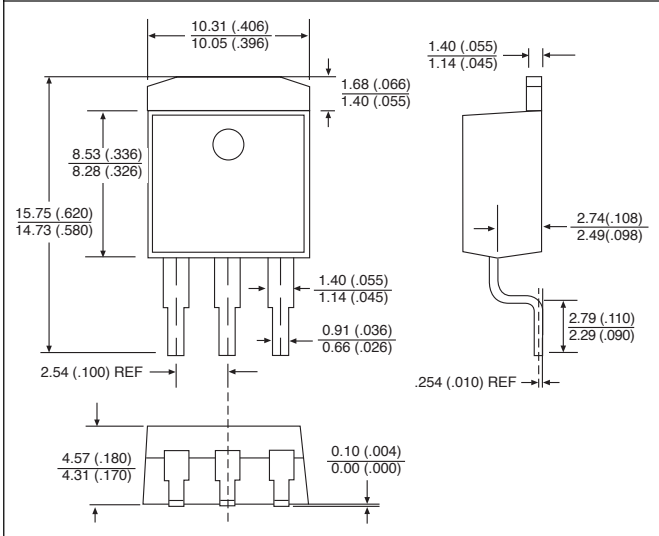

PACKAGE THERMAL DATA

Thermal Data		3L TO-220	3L D ² PAK	3L SOT-223	
R _{θJC}	typ	3.5	3.5	15	°C/W
R _{θJA}	typ	50	10 - 50*	156	°C/W

*Depending on thermal properties of substrate. R_{θJA} = R_{θJC} + R_{θCA}

3 Lead SOT-223 (ST)

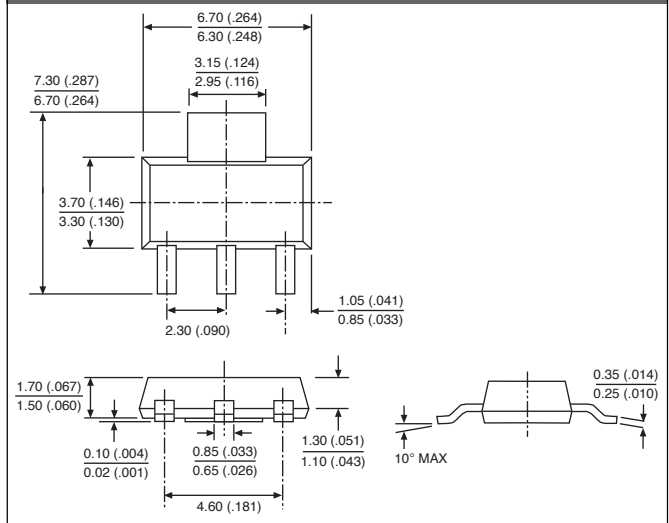

Ordering Information

Part Number	Type	Description
CS5201-1GT3	1A, adj. output	3 L TO-220 Straight
CS5201-1GDP3	1A, adj. output	3 L D ² PAK
CS5201-1GDPR3	1A, adj. output	3 L D ² PAK (tape & reel)
CS5201-1GST3	1A, adj. output	3 L SOT-223
CS5201-1GSTR3	1A, adj. output	3 L SOT-223 (tape & reel)

Cherry Semiconductor Corporation reserves the right to make changes to the specifications without notice. Please contact Cherry Semiconductor Corporation for the latest available information.



LittleDiode supplies new, hard to find or obsolete electronic components and semiconductors all over the world.

With over two million different components listed you are sure to find the part you need.

Feel free to visit us today at our online store:

LittleDiode.com

Looking forward to providing you with the best possible service.