

7A Adjustable Linear Regulator

Description

The CS5207-1 linear regulator provides 7A at adjustable voltages with an accuracy of $\pm 1.5\%$. Two external resistors are used to set the output voltage within a 1.25V to 13V range.

The regulator is intended for use as post regulator and microprocessor supply. The fast loop response and low dropout voltage make this regulator ideal for applications where low voltage operation and good transient response are important.

The circuit is designed to operate

with dropout voltages as low as 1V depending on the output current level. The maximum quiescent current is only 10mA at full load.

The regulator is fully protected against overload conditions with protection circuitry for Safe Operating Area (SOA), overcurrent and thermal shutdown.

The regulator is available in a TO-220 package. A 3.3V, fixed version is also available. Please consult factory for more information.

Features

- Output Current to 7A
- Output Trimmed to $\pm 1.5\%$
- Dropout Voltage
1.4V @ 7A
- Fast Transient Response
- Fault Protection Circuitry
Thermal Shutdown
Overcurrent Protection
Safe Area Protection
- 3.3V Fixed Version Available

Block Diagram

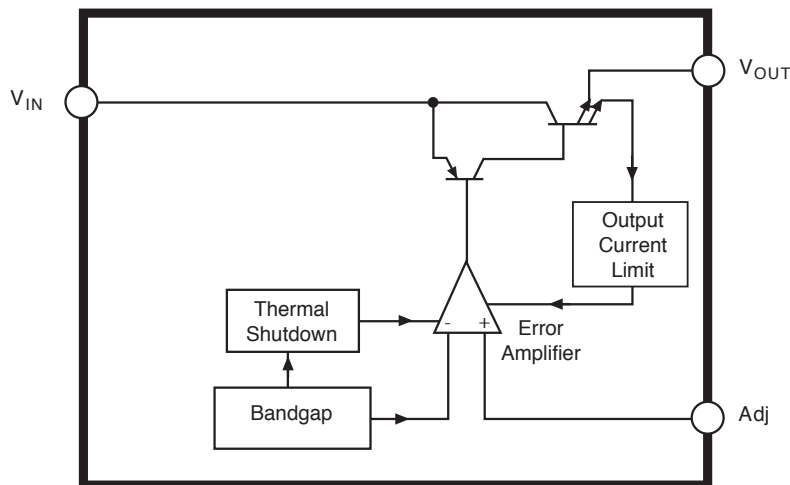

Package Options

3L TO-220
Tab (V_{OUT})

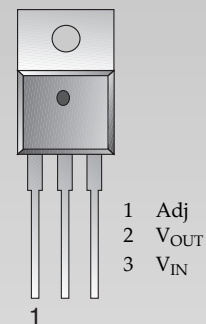

A 3.3V fixed version is also available.
*Consult factory.

Absolute Maximum Ratings

Supply Voltage, V_{CC}	17V
Operating Temperature Range	-40°C to 70°C
Junction Temperature	150°C
Storage Temperature Range	-60°C to 150°C
Lead Temperature Soldering	
Wave Solder (through hole styles only)	10 sec. max, 260°C peak

Electrical Characteristics: $C_{IN} = 10\mu\text{F}$, $C_{OUT} = 22\mu\text{F}$ Tantalum, $V_{IN} - V_{OUT} = 3\text{V}$, $V_{IN} \leq 15\text{V}$, $0^\circ\text{C} \leq T_A \leq 70^\circ\text{C}$, $T_J \leq +150^\circ\text{C}$, unless otherwise specified, $I_{full\ load} = 7\text{A}$.

PARAMETER	TEST CONDITIONS	MIN	TYP	MAX	UNIT
Adjustable Output Voltage					
Reference Voltage (Notes 1 and 2)	$V_{IN} - V_{OUT} = 1.6\text{V}$; $V_{Adj} = 0\text{V}$ $10\text{mA} \leq I_{OUT} \leq 7\text{A}$	1.235 (-1.5%)	1.254	1.272 (+1.5%)	V
Line Regulation	$1.6\text{V} \leq V_{IN} - V_{OUT} \leq 6\text{V}$; $I_{OUT} = 10\text{mA}$		0.04	0.20	%
Load Regulation (Notes 1 and 2)	$V_{IN} - V_{OUT} = 1.6\text{V}$; $10\text{mA} \leq I_{OUT} \leq 7\text{A}$		0.13	0.5	%
Dropout Voltage (Note 3)	$I_{OUT} = 7\text{A}$		1.4	1.55	V
Current Limit	$V_{IN} - V_{OUT} = 3\text{V}$; $T_J \geq 25^\circ\text{C}$	7.1	8.5		A
	$V_{IN} - V_{OUT} = 9\text{V}$		1.0		A
Minimum Load Current	$V_{IN} - V_{OUT} = 7\text{V}$		1.2	6	mA
Adjust Pin Current			50	100	μA
Adjust Pin Current Change	$1.6\text{V} \leq V_{IN} - V_{OUT} \leq 4\text{V}$; $10\text{mA} \leq I_{OUT} \leq 7\text{A}$		0.2	5.0	μA
Thermal Regulation	30ms pulse; $T_A = 25^\circ\text{C}$		0.003		%W
Ripple Rejection	$f = 120\text{Hz}$; $C_{Adj} = 25\mu\text{F}$; $I_{OUT} = 7\text{A}$		80		dB
Temperature Stability			0.5		%
RMS Output Noise	$10\text{Hz} \leq f \leq 10\text{kHz}$; $T_A = 25^\circ\text{C}$		0.003		% V_{OUT}
Thermal Shutdown		150	180		$^\circ\text{C}$
Thermal Shutdown Hysteresis			25		$^\circ\text{C}$

Note 1: Load regulation and output voltage are measured at a constant junction temperature by low duty cycle pulse testing. Changes in output voltage due to thermal gradients or temperature changes must be taken into account separately.

Note 2: Specifications apply for an external Kelvin sense connection at a point on the output pin 1/4" from the bottom of the package.

Note 3: Dropout voltage is a measurement of the minimum input/output differential at full load.

Package Pin Description

PACKAGE PIN #	PIN SYMBOL	FUNCTION
3L TO-220		
1	Adj	Adjust pin (low side of the internal reference).
2	V_{OUT}	Regulated output voltage (case).
3	V_{IN}	Input voltage.

Typical Performance Characteristics

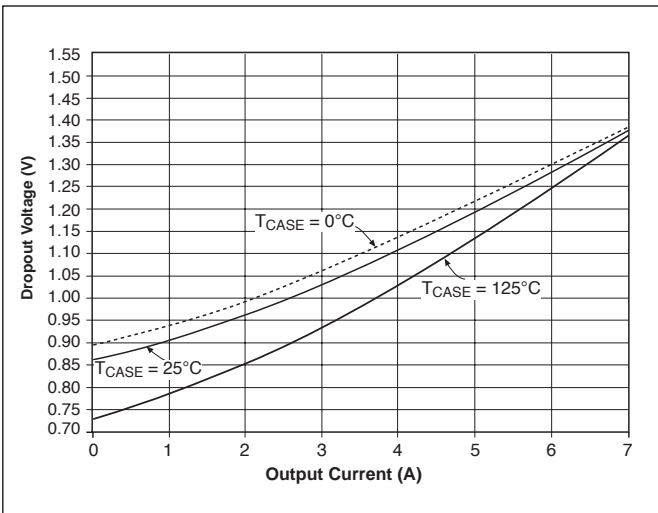

Dropout Voltage vs. Output Current

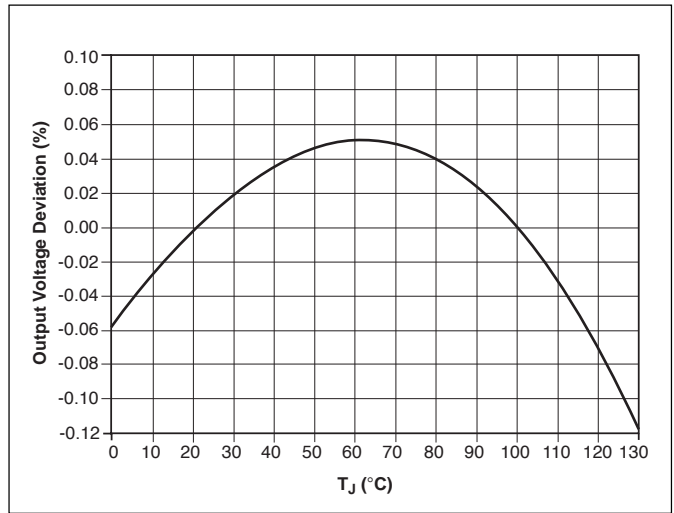

Reference Voltage vs. Temperature

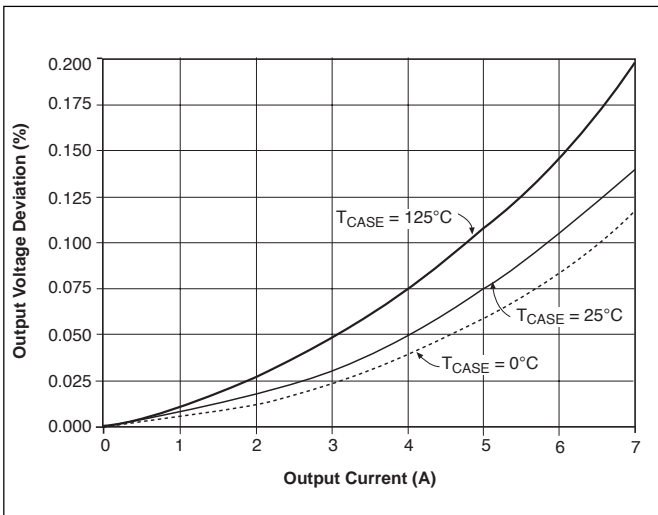

Load Regulation vs. Output Current

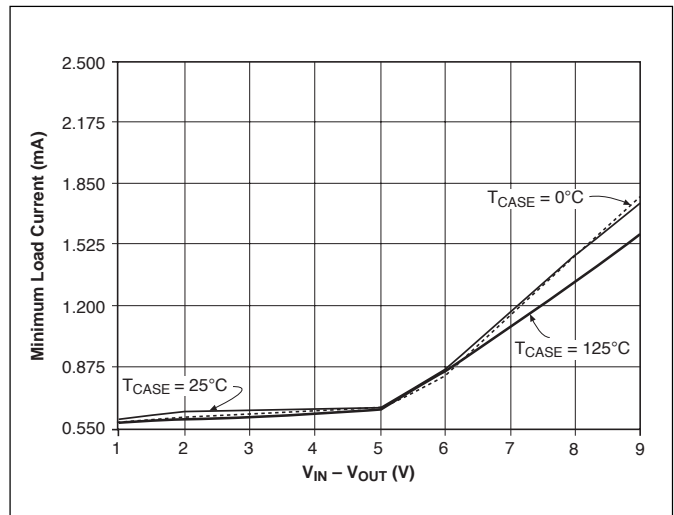

Minimum Load Current

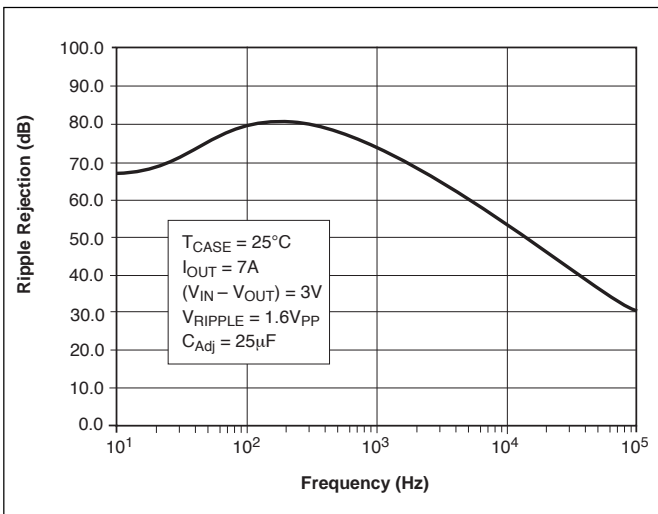

Ripple Rejection vs. Frequency

The CS5207-1 linear regulator provides adjustable voltages at currents up to 7A. The regulator is protected against short circuit, and include thermal shutdown and safe area protection (SOA) circuitry. The SOA protection circuitry decreases the maximum available output current as the input-output differential voltage increases.

The CS5207-1 has a composite PNP-NPN output transistor and requires an output capacitor for stability. A detailed procedure for selecting this capacitor is included in the Stability Considerations section.

Adjustable Operation

The adjustable regulator has an output voltage range of 1.25V to 13V. An external resistor divider sets the output voltage as shown in Figure 1. The regulator maintains a fixed 1.25V (typical) reference between the output pin and the adjust pin.

A resistor divider network R1 and R2 causes a fixed current to flow to ground. This current creates a voltage across R2 that adds to the 1.25V across R1 and sets the overall output voltage. The adjust pin current (typically 50 μ A) also flows through R2 and adds a small error that should be taken into account if precise adjustment of V_{OUT} is necessary.

The output voltage is set according to the formula:

$$V_{OUT} = V_{REF} \times \left(\frac{R1 + R2}{R1} \right) + I_{Adj} \times R2$$

The term $I_{Adj} \times R2$ represents the error added by the adjust pin current.

R1 is chosen so that the minimum load current is at least 10mA. R1 and R2 should be the same type, e.g. metal film for best tracking over temperature. The adjust pin is bypassed to improve the transient response and ripple rejection of the regulator.

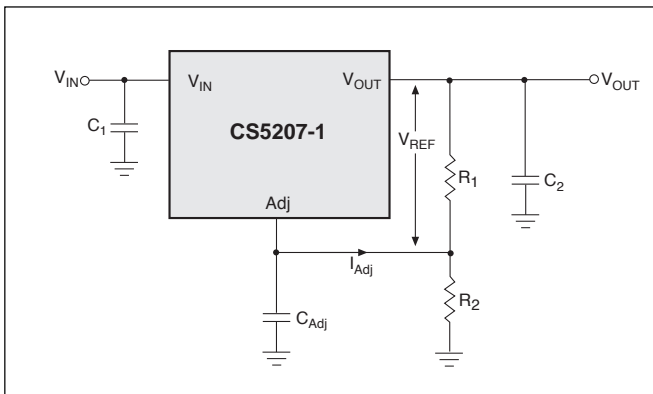

Figure 1. Resistor divider scheme for the adjustable version.

Stability Considerations

The output or compensation capacitor helps determine three main characteristics of a linear regulator: start-up delay, load transient response and loop stability.

The capacitor value and type is based on cost, availability, size and temperature constraints. A tantalum or aluminum electrolytic capacitor is best, since a film or ceramic capaci-

tor with almost zero ESR, can cause instability. The aluminum electrolytic capacitor is the least expensive solution. However, when the circuit operates at low temperatures, both the value and ESR of the capacitor will vary considerably. The capacitor manufacturers data sheet provides this information.

A 22 μ F tantalum capacitor will work for most applications, but with high current regulators such as the CS5207-1 the transient response and stability improve with higher values of capacitor. The majority of applications for this regulator involve large changes in load current so the output capacitor must supply the instantaneous load current. The ESR of the output capacitor causes an immediate drop in output voltage given by:

$$\Delta V = \Delta I \times ESR$$

For microprocessor applications it is customary to use an output capacitor network consisting of several tantalum and ceramic capacitors in parallel. This reduces the overall ESR and reduces the instantaneous output voltage drop under load transient conditions. The output capacitor network should be as close as possible to the load for the best results.

Protection Diodes

When large external capacitors are used with a linear regulator it is sometimes necessary to add protection diodes. If the input voltage of the regulator gets shorted, the output capacitor will discharge into the output of the regulator. The discharge current depends on the value of the capacitor, the output voltage and the rate at which V_{IN} drops. In the CS5207-1 regulator, the discharge path is through a large junction and protection diodes are not usually needed. If the regulator is used with large values of output capacitance and the input voltage is instantaneously shorted to ground, damage can occur. In this case, a diode connected as shown in Figure 2 is recommended.

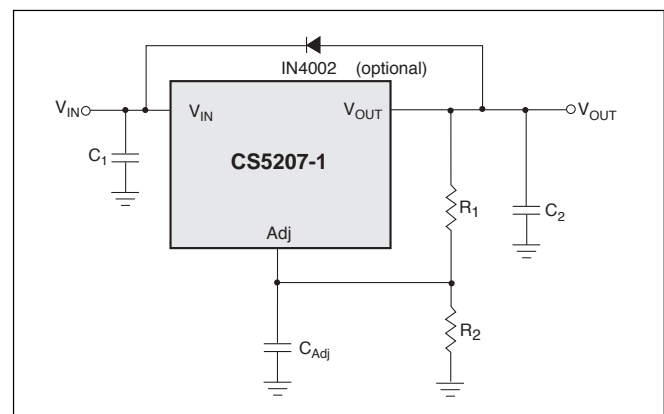

Figure 2. Protection diode scheme for adjustable output regulator.

Output Voltage Sensing

Since the CS5207-1 is a three terminal regulator, it is not possible to provide true remote load sensing. Load regulation is limited by the resistance of the conductors connecting the regulator to the load.

Best load regulation occurs when R1 is connected directly to the output pin of the regulator as shown in Figure 3. If R1 is connected to the load, R_C is multiplied by the divider ratio and the effective resistance between the regulator and the load becomes

$$R_C \times \left(\frac{R_1 + R_2}{R_1} \right)$$

R_C = conductor parasitic resistance

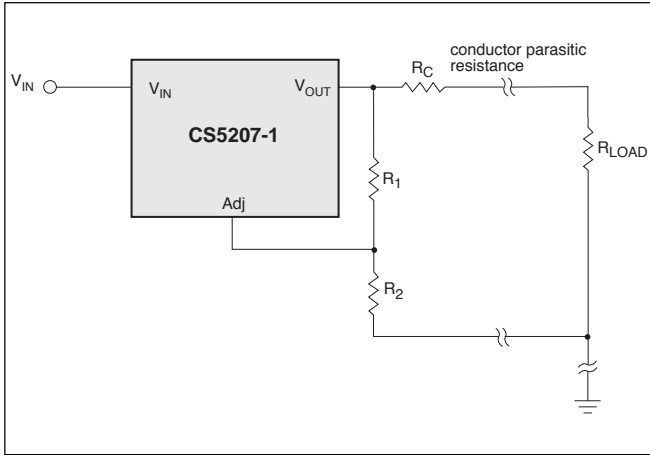

Figure 3. Grounding scheme for the adjustable output regulator to minimize parasitics.

Calculating Power Dissipation and Heat Sink Requirements

The CS5207-1 linear regulator includes thermal shutdown and safe operating area circuitry to protect the device. High power regulators such as this usually operate at high junction temperatures so it is important to calculate the power dissipation and junction temperatures accurately to ensure that an adequate heat sink is used.

The case is connected to V_{OUT} on the CS5207-1, electrical isolation may be required for some applications. Thermal compound should always be used with high current regulators such as these.

The thermal characteristics of an IC depend on the following four factors:

1. Maximum Ambient Temperature T_A (°C)
2. Power dissipation P_D (Watts)
3. Maximum junction temperature T_J (°C)
4. Thermal resistance junction to ambient R_{θJA} (C/W)

These four are related by the equation

$$T_J = T_A + P_D \times R_{\theta JA} \tag{1}$$

The maximum ambient temperature and the power dissipation are determined by the design while the maximum junction temperature and the thermal resistance depend on the manufacturer and the package type.

The maximum power dissipation for a regulator is:

$$P_{D(max)} = (V_{IN(max)} - V_{OUT(min)}) I_{OUT(max)} + V_{IN(max)} I_Q \tag{2}$$

where

V_{IN(max)} is the maximum input voltage,

V_{OUT(min)} is the minimum output voltage,

I_{OUT(max)} is the maximum output current, for the application

I_Q is the maximum quiescent current at I_{OUT(max)}.

A heat sink effectively increases the surface area of the package to improve the flow of heat away from the IC and into the surrounding air.

Each material in the heat flow path between the IC and the outside environment has a thermal resistance. Like series electrical resistances, these resistances are summed to determine R_{θJA}, the total thermal resistance between the junction and the surrounding air.

1. Thermal Resistance of the junction to case, R_{θJC} (°C/W)
2. Thermal Resistance of the case to Heat Sink, R_{θCS} (°C/W)
3. Thermal Resistance of the Heat Sink to the ambient air, R_{θSA} (°C/W)

These are connected by the equation:

$$R_{\theta JA} = R_{\theta JC} + R_{\theta CS} + R_{\theta SA} \tag{3}$$

The value for R_{θJA} is calculated using equation (3) and the result can be substituted in equation (1).

The value for R_{θJC} is normally quoted as a single figure for a given package type based on an average die size. For a high current regulator such as the CS5207-1 the majority of the heat is generated in the power transistor section. The value for R_{θSA} depends on the heat sink type, while R_{θCS} depends on factors such as package type, heat sink interface (is an insulator and thermal grease used?), and the contact area between the heat sink and the package. Once these calculations are complete, the maximum permissible value of R_{θJA} can be calculated and the proper heat sink selected. For further discussion on heat sink selection, see application note "Thermal Management for Linear Regulators."

Package Specification

PACKAGE DIMENSIONS IN mm(INCHES)

PACKAGE THERMAL DATA

Thermal Data		3L TO-220	
$R_{\theta JC}$	typ	1.6	$^{\circ}C/W$
$R_{\theta JA}$	typ	50	$^{\circ}C/W$

3 Lead TO-220 (T) Straight

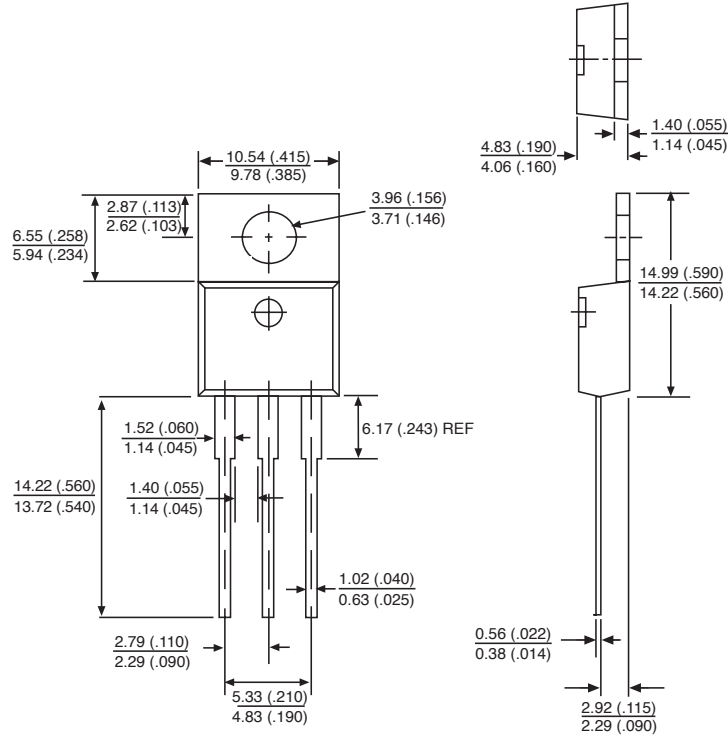

Ordering Information

Part Number	Type	Description
CS5207-1GT3	7A, adj. output	3 L TO-220 Straight
CS5207-3GT3	7A, fixed output	3L TO-220 Straight

Cherry Semiconductor Corporation reserves the right to make changes to the specifications without notice. Please contact Cherry Semiconductor Corporation for the latest available information.



LittleDiode supplies new, hard to find or obsolete electronic components and semiconductors all over the world.

With over two million different components listed you are sure to find the part you need.

Feel free to visit us today at our online store:

LittleDiode.com

Looking forward to providing you with the best possible service.