

CDB5510/11/12/13 Evaluation Board and Software

Features

- Supports the CS5510, CS5511, CS5512, and CS5513 8-pin ADCs
- On-board Oscillator (CS5510/12)
- RS-232 Serial Communication with PC
- On-board Microcontroller
- On-board Voltage Reference
- LabWindows®/CVI® Evaluation Software
 - Chip Control and Data Capture
 - FFT Analysis
 - Time Domain Analysis
 - Noise Histogram Analysis
- Includes CDB551x, CS551X sample, and Software

General Description

The CDB5510/11/12/13 is an inexpensive tool designed to evaluate the performance of the CS5510/11/12/13 8-pin Analog to Digital Converters. This document, as well as the CS5510/11/12/13 data sheet should be read thoroughly before using the CDB5510/11/12/13 Evaluation System.

The evaluation system consists of a CDB5510 Board and PC software which allows the user to easily capture and analyze data. The provided analysis functions in the software include Time Domain Analysis, Histogram Analysis, and Frequency Domain Analysis.

ORDERING INFORMATION:

CDB5510/11/12/13	Evaluation System
Includes CDB5510 and One Sample	

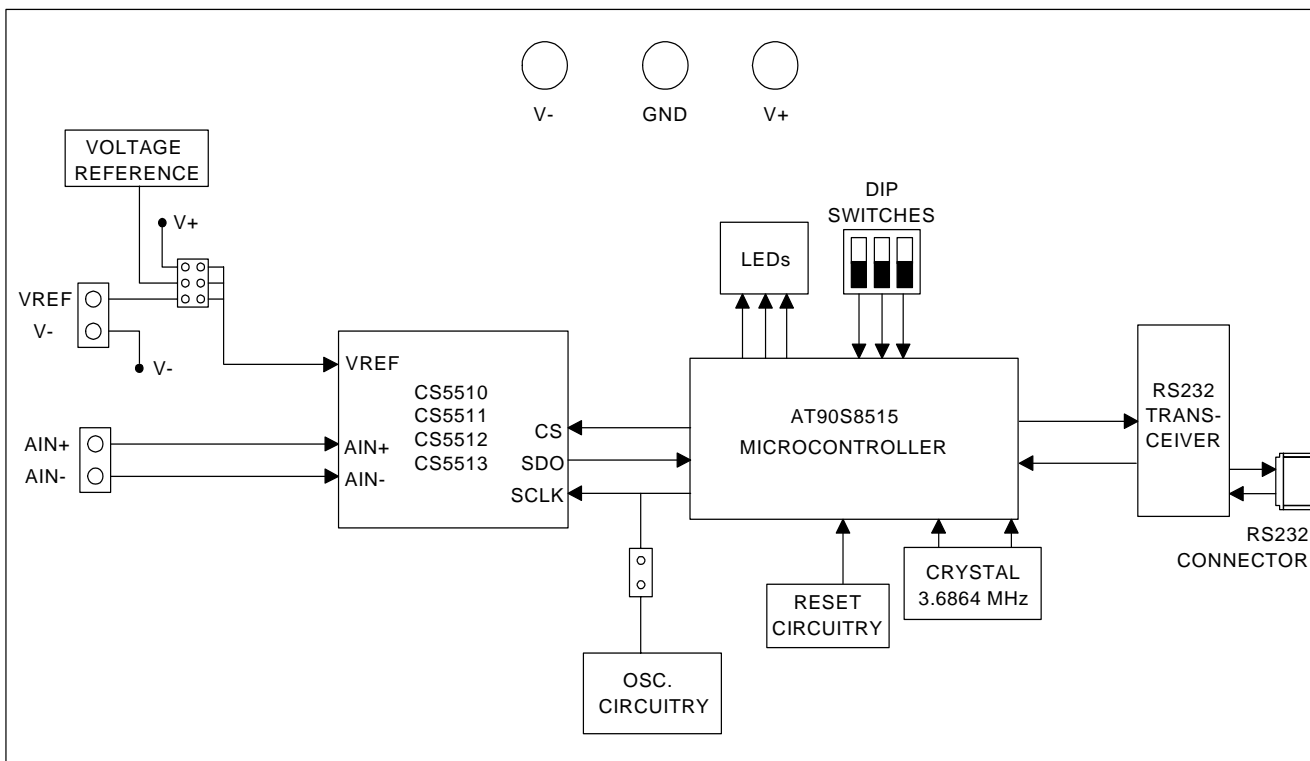

Preliminary Product Information

This document contains information for a new product. Cirrus Logic reserves the right to modify this product without notice.

TABLE OF CONTENTS

1. HARDWARE	3
1.1 Introduction	3
1.2 Power Supply Options	3
1.3 Analog Inputs	3
1.4 Voltage Reference Options	3
1.5 Clocking Options	4
1.6 PC Interface	5
1.7 Adding an Amplifier to the CDB5510	5
1.8 Interfacing to an External Controller	5
2. SOFTWARE	6
2.1 Installation Procedure	6
2.2 Using the Software	6
2.2.1 Selecting the COM Port and Part	6
2.2.2 Setup Window Functions	6
2.3 Data Collection Window Overview	8
2.3.1 Histogram Plots	9
2.3.2 Frequency Domain (FFT) Plots	9
2.3.3 Time Domain Plots	10
3. SCHEMATICS	14

LIST OF FIGURES

Figure 1. Title Screen	10
Figure 2. Setup Window	11
Figure 3. Frequency Domain Analysis	12
Figure 4. Configuration Panel.....	12
Figure 5. Time Domain Analysis	13
Figure 6. Histogram Analysis	13
Figure 7. CDB5510 Power Supply Schematic.....	14
Figure 8. CDB5510 Reference and ADC Schematic.....	15
Figure 9. CDB5510 Amplifier Schematic (not populated).....	16
Figure 10. CDB5510 Microcontroller Schematic	17
Figure 11. CDB5510 RS232 and Oscillator Schematic.....	18
Figure 12. CDB5510 Silkscreen Layout	19
Figure 13. CDB5510 Top Side Layout	20
Figure 14. CDB5510 Bottom Side Layout	21

Contacting Cirrus Logic Support

For a complete listing of Direct Sales, Distributor, and Sales Representative contacts, visit the Cirrus Logic web site at:
<http://www.cirrus.com/corporate/contacts>

LabWindows and CVI are registered trademarks of National Instruments Corporation, MICROWIRE is a trademark of National Semiconductor Corporation, SPI is a registered trademark of International Business Machines Corporation, Windows 95 is a registered trademark of Microsoft Corporation.

Preliminary product information describes products which are in production, but for which full characterization data is not yet available. Advance product information describes products which are in development and subject to development changes. Cirrus Logic, Inc. has made best efforts to ensure that the information contained in this document is accurate and reliable. However, the information is subject to change without notice and is provided "AS IS" without warranty of any kind (express or implied). No responsibility is assumed by Cirrus Logic, Inc. for the use of this information, nor for infringements of patents or other rights of third parties. This document is the property of Cirrus Logic, Inc. and implies no license under patents, copyrights, trademarks, or trade secrets. No part of this publication may be copied, reproduced, stored in a retrieval system, or transmitted, in any form or by any means (electronic, mechanical, photographic, or otherwise) without the prior written consent of Cirrus Logic, Inc. Items from any Cirrus Logic website or disk may be printed for use by the user. However, no part of the printout or electronic files may be copied, reproduced, stored in a retrieval system, or transmitted, in any form or by any means (electronic, mechanical, photographic, or otherwise) without the prior written consent of Cirrus Logic, Inc. Furthermore, no part of this publication may be used as a basis for manufacture or sale of any items without the prior written consent of Cirrus Logic, Inc. The names of products of Cirrus Logic, Inc. or other vendors and suppliers appearing in this document may be trademarks or service marks of their respective owners which may be registered in some jurisdictions. A list of Cirrus Logic, Inc. trademarks and service marks can be found at <http://www.cirrus.com>.

1. HARDWARE

1.1 Introduction

The CDB5510/11/12/13 evaluation system provides a quick means of testing the CS5510/11/12/13 Analog-to-Digital Converters (ADCs). The CDB5510 evaluation board accepts any of the four converters via an 8-pin SOIC socket, and interfaces directly to a PC running through an RS-232 serial interface.

The included analysis software allows the user to control the various functions of the CS5510/11/12/13, as well as capture and save data. The software also provides data analysis tools to display the time domain, frequency domain, and noise histogram performance for a captured set of data.

1.2 Power Supply Options

The CS5510/11/12/13 ADCs are designed to operate from a supply voltage difference of 5 to 6 V between V+ and V-. The parts may be run from a single 5 V supply, or any combination of voltages that produce a 5 V span, such as +3 V and -2 V or ± 2.5 V. The CDB5510 evaluation board supports both single and dual supply configurations. For a single supply, both the V- and GND posts should be connected to 0 V, and the V+ post should be connected to the positive supply voltage. For dual supply configurations, the GND post should be connected to 0 V, the positive supply should be connected to the V+ post, and the negative supply should be connected to the V- post. Because the RS-232 transceiver used on the board requires at least 3 V for its supply voltage, it is recommended that the V+ post always be at least 3 V for proper operation of the evaluation board. If a different microcontroller is interfaced to the CS5510/11/12/13 through HDR6, other supply voltages may be used.

1.3 Analog Inputs

Analog input signals can be connected to the converter's inputs via the CDB5510's AIN+ and AIN- inputs (connector J3). Note that a simple RC network filters the input to reduce broadband noise. Both of the analog inputs can also be tied to the V-supply by changing the position of HDR4 and HDR5, or to the output of the amplifier section as shown in Table 1. For a differential input the jumpers should be set to the "Direct Differential Input" setting, and for a single-ended input on AIN+, the jumpers should be set to the "Direct Single-Ended Input" setting. The jumpers can also be set to configure an amplifier input, if it is installed on the evaluation board. The amplifier section of the board is discussed in more detail in section 1.7.

Input	HDR4	HDR5
Direct Differential Input	AIN+ <input checked="" type="checkbox"/> <input type="checkbox"/> AIN+ AMP+ <input type="checkbox"/> <input type="checkbox"/> AIN+ V- <input type="checkbox"/> <input type="checkbox"/> AIN+	AIN- <input type="checkbox"/> <input checked="" type="checkbox"/> AIN- AMP- <input type="checkbox"/> <input type="checkbox"/> AIN- V- <input type="checkbox"/> <input type="checkbox"/> AIN-
Direct Single-Ended Input	AIN+ <input checked="" type="checkbox"/> <input type="checkbox"/> AIN+ AMP+ <input type="checkbox"/> <input type="checkbox"/> AIN+ V- <input type="checkbox"/> <input type="checkbox"/> AIN+	AIN- <input type="checkbox"/> <input type="checkbox"/> AIN- AMP- <input type="checkbox"/> <input type="checkbox"/> AIN- V- <input type="checkbox"/> <input checked="" type="checkbox"/> AIN-
Differential Amplifier Input	AIN+ <input type="checkbox"/> <input type="checkbox"/> AIN+ AMP+ <input checked="" type="checkbox"/> <input checked="" type="checkbox"/> AIN+ V- <input type="checkbox"/> <input type="checkbox"/> AIN+	AIN- <input type="checkbox"/> <input type="checkbox"/> AIN- AMP- <input checked="" type="checkbox"/> <input checked="" type="checkbox"/> AIN- V- <input type="checkbox"/> <input type="checkbox"/> AIN-
Single-Ended Amplifier Input	AIN+ <input type="checkbox"/> <input type="checkbox"/> AIN+ AMP+ <input checked="" type="checkbox"/> <input checked="" type="checkbox"/> AIN+ V- <input type="checkbox"/> <input type="checkbox"/> AIN+	AIN- <input type="checkbox"/> <input type="checkbox"/> AIN- AMP- <input type="checkbox"/> <input type="checkbox"/> AIN- V- <input type="checkbox"/> <input checked="" type="checkbox"/> AIN-

Table 1. Analog Input Selection With HDR4 and HDR5

1.4 Voltage Reference Options

The evaluation system provides three voltage reference options. The VREF pin can be connected to the on-board 2.5V reference, to the positive supply rail, or to an external voltage reference source via HDR3, as shown in Table 2. When the HDR3 jumper on the CDB5510 is in the "V+" position, the eval board's supply voltage is selected. When this jumper is in the "LT1019" position, the on-board reference provides an absolute voltage level of 2.5 volts (the LT1019 was chosen for its low drift, typ-

ically 5ppm/°C). By setting HDR3's jumper to the "REF" position, the user can supply an external voltage reference to J1's REF input. V- is also provided at connector J1 to allow an easy connection to the negative supply. (Application Note 4 on Cirrus Logic's web site details various voltage references).

Reference	Description	HDR3
V+	Selects Analog Power Supply	V+ <input checked="" type="checkbox"/> VREF LT1019 <input type="checkbox"/> VREF REF <input type="checkbox"/> VREF
LT1019	Selects on board LT1019 Reference (5ppm/°C)	V+ <input type="checkbox"/> VREF LT1019 <input checked="" type="checkbox"/> VREF REF <input type="checkbox"/> VREF
EXTERNAL	Selects external reference source connected to J1	V+ <input type="checkbox"/> VREF LT1019 <input type="checkbox"/> VREF REF <input checked="" type="checkbox"/> VREF

Table 2. Voltage Reference Selection Using HDR3

1.5 Clocking Options

The CS5510/11/12/13 are very simple ADCs, intended to continuously convert and output data when not in sleep mode. The CS5510 and CS5512 require an external clock signal on the SCLK input pin to run properly. The CDB5510 evaluation board provides three options for this clock source:

1) The microcontroller can be used to generate a clock for the CS5510/12. The microcontroller's clock can be selected by removing the jumper from HDR7 on the CDB5510 board, and selecting the "CS5510/12 Clock from microcontroller" option in the software. The DIP switches on the evaluation board should be set as shown in the "CS5510/12 Clock from 8515" section of Table 3. The clock frequency can be selected by changing the "Oscillator Frequency" box in the software. Note that the frequency options are limited by the microcontroller's counter/timer circuitry, which divides the 3.6864 MHz clock by integer values to produce the clock output.

2) The 32 kHz on-board oscillator circuit (shown in Figure 11) can be used by connecting HDR7 on the CDB5510 board and selecting the "On-board or external clock source" option in the software. The DIP switches on the evaluation board should be set as shown in the "CS5510/12 External Clock" section of Table 3.

3) An external clock can be provided by the user, and connected to the SCLK post on HDR7. The "On-board or external clock source" option in the software should be selected when using an external clock source, and the DIP switches on the evaluation board should be set as shown in the "CS5510/12 External Clock" section of Table 3.

The CS5511 and CS5513 include an internal oscillator, and as such, need no external oscillator to run. When using the CS5511 or CS5513, HDR7 on the CDB5510 board should be left disconnected, and the "CS5511/13 Internally Clocked" option should be selected in the software. Likewise, the

Eval Board Mode	SW1 Settings
CS5511/13 Internally Clocked X is OPEN A is OPEN B is OPEN	
CS5510/12 Clock From 8515 X is OPEN A is CLOSED B is CLOSED	
CS5510/12 External Clock X is OPEN A is OPEN B is CLOSED	
RS-232 Test Mode X is CLOSED A is CLOSED B is CLOSED	

Table 3. DIP Switch Settings

DIP switches on the CDB5510 should be set to the “CS5511/13 Internally Clocked” section of Table 3.

1.6 PC Interface

The evaluation system comes with software and an RS-232 cable to link the evaluation board to the PC. The executable software was developed with LabWindows/CVI and meant to run under Windows® 95 or 98. After installing the software, read the readme.txt file for any last minute changes in the software. Additionally, *Section 2.0: Software* in this document further details how to install and use the software.

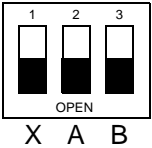
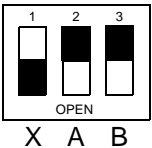
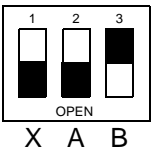
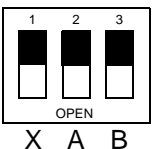
1.7 Adding an Amplifier to the CDB5510

The CDB5510 is laid out so that a standard 8-pin SOIC dual op-amp of the user's choosing can be installed on the board to allow evaluation of the CS5510/11/12/13's performance with an op-amp front-end. If an op-amp front-end is desired, the additional components such as feedback resistors and bypass capacitors must also be installed on the board. A schematic of the amplifier section including some typical component values is shown in Figure 9. The amplifier is configured to operate in either a single non-inverting, or a dual differential configuration. The mode of operation can be selected by changing the jumper on HDR2. Using the components shown in Figure 9, the gain of the am-

plifier will be 10 in the single configuration, or 21 in the dual configuration. Different gain values can be achieved by changing the value of resistors R6, R17, and R18.

1.8 Interfacing to an External Controller

The ADC serial interface is *SPI*® and *MICROWIRE*™ compatible. The interface control lines (\overline{CS} , SDO, and SCLK) are connected to the 8515 microcontroller on the CDB5510. The ADCs can be interfaced to an external microcontroller through HDR6 on the CDB5510. To accomplish this, the CDB5510 board must be modified in one of three ways: 1) remove the microcontroller from its socket, 2) remove resistors R20-R22, or 3) cut the interface control traces between the microcontroller and the header.

Schematic & Layout Review Service

Confirm Optimum
Schematic & Layout
Before Building Your Board.

For Our Free Review Service
Call Applications Engineering.



C a l l : (5 1 2) 4 4 5 - 7 2 2 2

2. SOFTWARE

2.1 Installation Procedure

- 1) Turn on the PC, running Windows 95 or 98.
- 2) Insert the Installation Diskette #1 into the PC.
- 3) Select the Run option from the Start menu.
- 4) At the prompt, type: A:\SETUP.EXE <enter>.
- 5) The program will begin installation.
- 6) If it has not already been installed on the PC, the user will be prompted to enter the directory in which to install the CVI Run-Time Engine. The Run-Time Engine manages executables created with LabWindows/CVI. If the default directory is acceptable, select OK and the Run-Time Engine will be installed there.
- 7) After the Run-Time Engine is installed, the user is prompted to enter the directory in which to install the Eval5510/11/12/13 software. Select OK to accept the default directory, or choose an alternate directory.
- 8) Once the program is installed, it can be run by double clicking on the Eval5510/11/12/13 icon, or through the Start menu.

Note: The software is written to run with 640 x 480 resolution; however, it will work with 1024 x 768 resolution. If the user interface seems to be a little small, the user might consider setting the display settings to 640 x 480. (640 x 480 was chosen to accommodate a variety of computers).

2.2 Using the Software

At start-up, the title screen appears first (Figure 1). This window contains information concerning the software's title, revision number, copyright date, etc. Additionally, at the top of the screen is a menu bar which displays user options. Notice, the menu bar item *Window* is initially disabled. This eliminates any conflicts with the mouse or concurrent use of modems. Before proceeding any further, the

user is prompted to select the serial communication port.

2.2.1 Selecting the COM Port and Part

To initialize a port, pull down option *ComPorts* from the menu bar and select either COM1 or COM2. Next, the user is prompted to select the appropriate part under the *Parts* menu. After a port is initialized and the correct part is selected, it is a good idea to test the RS-232 link between the PC and the evaluation board. To do this, pull down the *Setup* menu from the menu bar and select the option TESTRS232. The user is then prompted to set the evaluation board's test switches to 111 and then reset the board. Once this is done, proceed with the test. If the test fails, check the hardware connection and repeat again. Otherwise, set the test switches back to the correct mode as specified in this document, and press reset again.

2.2.2 Setup Window Functions

To make sure that the software and evaluation board are set up correctly, it is recommended that the user proceed to the Setup Window and test the functionality of the part before proceeding (Figure 2). To access the Setup Window, the user can pull down the Window menu item, or press F1 on the keyboard. The following describes the various options and indicators in the Setup Window.

Clocking Options: This pull-down menu allows the user to select the type of clock that will be used with the ADC, so that the software knows what to expect from the microcontroller. Selecting from this menu also gives the user the DIP switch options that they must set on the evaluation board. There are three options available on this menu:

CS5511/13 Internally Clocked - This option means that a CS5511 or CS5513 is being used, and the microcontroller will only provide an SCLK when clocking data from the ADC. Be sure that no jumper is installed on HDR7 of the CDB5510 when this

option is selected, or the board will not function properly.

CS5510/12 Clock from Microcontroller - This option tells the software that a CS5510 or CS5512 is being used, and that the microcontroller will provide the ADC with a master clock. The microcontroller's clock frequency is user-selectable from the Setup Window. The clock frequency is limited to integer sub-multiples of the microcontroller's 3.6864 MHz master clock ($3.6864 \text{ MHz} / N$). Be sure that no jumper is installed on HDR7 of the CDB5510 when this option is selected, to avoid contention with the on-board oscillator.

CS5510/12 On-Board or External Clock Source - This option tells the software that a CD5510 or CS5512 is being used, and that the master clock from the part will be coming from an outside source. If the on-board 32 kHz oscillator is to be used as the clock source, a jumper should be installed on HDR7 of the CDB5510. If a different clock source is to be used, no jumper should be installed, and the clock source should be connected to the pin labeled SCLK (the top pin) of HDR7 or to the pin labeled SCLK (the lower-left pin) on HDR6.

Oscillator Frequency: This box displays the frequency of the oscillator that the ADC is running on. When using an external clock source, the user can type in the frequency of the clock source, and the FFT plots will scale accordingly. When using the microcontroller as a clock source, the user should adjust this value until it is close to the desired frequency. The value in this box will automatically be adjusted to a frequency that the microcontroller can provide. When using a CS5511 or CS5513, the "Get Internal Freq." option should be used to determine the converter's internal oscillator frequency.

Sampling Frequency: This box displays the computed sampling frequency for the specified oscillator frequency. This number is used when performing FFT analysis.

Sleep Mode: This button allows the user to put the ADC in sleep mode. The microcontroller will set SCLK high, and the ADC will power down according to the data sheet specifications. If an external clock or the on-board oscillator is used, this option should remain off.

Get Internal Freq.: This button is only visible when the CS5511 or CS5513 is being used. When pressed, the microcontroller will time the conversion cycle of the ADC and the PC software will compute the sampling rate and oscillator frequency based on the results. This button should be pressed when using a CS5511 or CS5513 before collecting data to ensure that any FFT plots are scaled properly.

Acquire: When this button is pressed, the microcontroller will begin collecting conversions from the ADC and sending them to the PC. The PC stores the conversions as a small sample set. From the sample set collected, the high, the low, peak-to-peak, average, and standard deviation, are computed (the size of the data set is set by the "Num To Average" box) and then the display icons are updated. The most recent conversion will be displayed in the Last Conversion box in hexadecimal format. This process continues until the STOP button is pressed, or until another window is selected.

Num To Average: Input icon that sets the size of the data conversion set referred to when the Acquire button is pressed.

OF and OD: These two icons represent the OF and OD flags that are part of the ADC's output word. If one or both of these flags are set, the appropriate icon will light up.

Software Calibration Features: Because the CS5510/11/12/13 have no built-in calibration features, any calibration functionality must be implemented in software. The following functions, found in the *Software Calibration Box*, allow the user to perform software-based calibrations on the ADCs.

Offset Cal - This button allows the user to perform a software offset calibration. To do so, the user should connect analog inputs AIN+ and AIN- to a zero point, and press the Offset Cal Button. The microcontroller will then obtain a number of conversions from the ADC (dictated by the Cals to Avg. Box) and average these conversions together. The result will be stored in memory and displayed in the Offset Box.

Gain Cal - This button allows the user to perform a software gain calibration. To do this, the user should connect the analog inputs AIN+ and AIN- to a full-scale value (at least 10% less than the maximum full scale of the part, to maintain accuracy) and press the Gain Cal Button. The microcontroller will then obtain a number of conversions from the ADC (dictated by the Cals to Avg. Box), subtract out the contents of the Offset Box, and average the results together. From this, a gain factor is computed, stored in memory, and displayed in the Gain Factor Box.

Multiply Gain - The Multiply Gain (2x and 1/2) Buttons allow the user to easily divide or multiply the gain factor by 2. This feature can be used to digitally scale the output of the part in software by factors of two.

Cal On/Cal Off - This switch allows the user to apply the calibration values to the data collected in the Setup Window. When the switch is in the Off position, the collected results will reflect the raw conversion data from the ADC. When the switch is in the On position, the value in the Offset Box will be subtracted from the conversions, and the result will be multiplied by the value in the Gain Factor Box. The collected results will reflect the value after the calibration data has been applied.

2.3 Data Collection Window Overview

The Data Collection Window is used to collect and analyze data sets using the evaluation board. The software supports Time Domain, Frequency Domain (FFT) and Histogram analysis of collected

data sets. To go to the Data Collection Window, pull down the *Window* menu item and select “Data Collection Window”, or press F2 on the keyboard. The following controls and indicators are present in the Data Collection Window regardless of what test is being performed.

COLLECT: Initiates the data conversion collection process. COLLECT has two modes of operation: collect from file or collect from converter. To collect from a file, a previously saved file from the ComPorts->DISK menu bar option must be selected. Once a file is selected, its content will displayed on the graph when the COLLECT button is pressed. If the user is collecting conversions from the evaluation board to analyze, the appropriate COM port must be selected. The user is then free to collect the preset number of conversions (preset by the CONFIG pop-up menu discussed below). Notice, there is a significant acquisition time difference between collecting from a file and collecting from the evaluation board. Data can only be collected from the evaluation board at the converter’s current sampling frequency, and will take much longer than retrieving previously collected data from a file.

CANCEL: This button allows the user to exit from the COLLECT algorithm during a collection. It is recommended that the user reset the evaluation board after pressing this button, so that the evaluation board will stop collecting data and wait for the next command.

OUTPUT: This button calls up a pop-up window which allows the user to save the collected data set to a file or print out the information on the screen. Two printing options are available: printing only the plot data, and printing the entire screen including the calculated statistics for the current analysis mode.

ZOOM: Pressing this button allows the user to zoom in on a specific portion of the current graph. To zoom, click on the ZOOM icon, then click on the

graph to select one corner of the desired Zoom area. When prompted, click on the graph again to select the opposite corner of the desired zoom area. Once an area has been zoomed to, the printing functions can be used to print a hard copy of that region. Click on RESTORE when done with the zoom function to display the entire data set graph. A region can also be magnified further by clicking on the ZOOM button again.

RESTORE: Restores the display of the graph after zoom has been entered. No matter how far in the user has magnified the data plot, the RESTORE button will return to the fully zoomed-out data plot.

TIME DOMAIN / FFT / HISTOGRAM Selector: This pull-down menu selects between time domain, frequency domain, and histogram mode to perform and display the appropriate analysis of the data set.

Cal On/Cal Off: This switch allows the user to apply the calibration values to the data set as it is collected. When the switch is in the Off position, the collected results will reflect the raw conversion data from the ADC. When the switch is in the On position, the calibration values from the Setup Window will be applied to the data as it is collected. This switch must be set to the desired value before data is collected, since the calibration values can only be applied during the collection process.

CONFIG: Opens a pop-up panel (Figure 4) to configure how much data is to be collected, and how to process the data once it is collected. The following are controls and indicators associated with the CONFIG panel.

SAMPLES: Allows the user to select the number of conversions to collect, between 16 and 32,768.

WINDOW: Used in the Power Spectrum Window to calculate the FFT. Windowing algorithms include the Blackman, Blackman-Harris, Hanning, 5-term Hodia, and 7-term Hodia. The 5-term Hodia and 7-term Hodia are windowing algorithms devel-

oped at Cirrus Logic. If information concerning these algorithms is needed, call technical support.

AVERAGE: Sets the number of consecutive FFT's to perform and average.

LIMITED NOISE BANDWIDTH: Limits the amount of noise in the converters bandwidth. Default is 0 Hz.

OK: Accept the changes and close the window

2.3.1 Histogram Plots

The following is a description of the indicators associated with Histogram analysis (Figure 6).

BIN: Displays the x-axis value of the cursor on the Histogram. This represents the output code from the part.

MAGNITUDE: Displays the y-axis value of the cursor on the Histogram. This represents the number of times a certain output code occurred in the collected data set.

MAXIMUM: Indicator for the maximum value of the collected data set.

MEAN: Indicator for the mean (average) of the data sample set.

MINIMUM: Indicator for the minimum value of the collected data set.

STD. DEV.: Indicator for the Standard Deviation of the collected data set.

VARIANCE: Indicates the Variance for the current data set.

2.3.2 Frequency Domain (FFT) Plots

The following describe the indicators associated with Frequency Domain (FFT) analysis (Figure 3).

FREQUENCY: Displays the x-axis value of the cursor on the FFT display. This represents the center frequency of the currently selected bin in Hz.

MAGNITUDE: Displays the y-axis value of the cursor on the FFT display. This represents the total power in dB contained in the selected bin.

S/D: Indicator for the Signal-to-Distortion Ratio, in dB. This is the ratio of the signal magnitude to the magnitude of the first four harmonics.

S/N+D: Indicator for the Signal-to-Noise + Distortion Ratio in dB. This is the ratio of the signal magnitude to the magnitude of the first four harmonics and the noise.

SNR: Indicator for the Signal-to-Noise Ratio in dB. This is the ratio of the signal magnitude to the magnitude of the noise (an average noise value is included in place of the first four harmonics).

S/PN: Indicator for the Signal-to-Peak Noise Ratio in dB. This is the ratio of the signal magnitude to the magnitude of the highest noise component not included in the harmonics of the signal.

of AVG: Displays the number of FFT's averaged in the current display.

2.3.3 Time Domain Plots

The following indicators are associated with Time Domain analysis (Figure 5).

COUNT: Displays current x-position of the cursor on the time domain display. This represents the position of the code within the collected sample set.

MAGNITUDE: Displays current y-position of the cursor on the time domain display. This represents the actual code from the converter.

MAXIMUM: Indicator for the maximum value of the collected data set.

MINIMUM: Indicator for the minimum value of the collected data set.

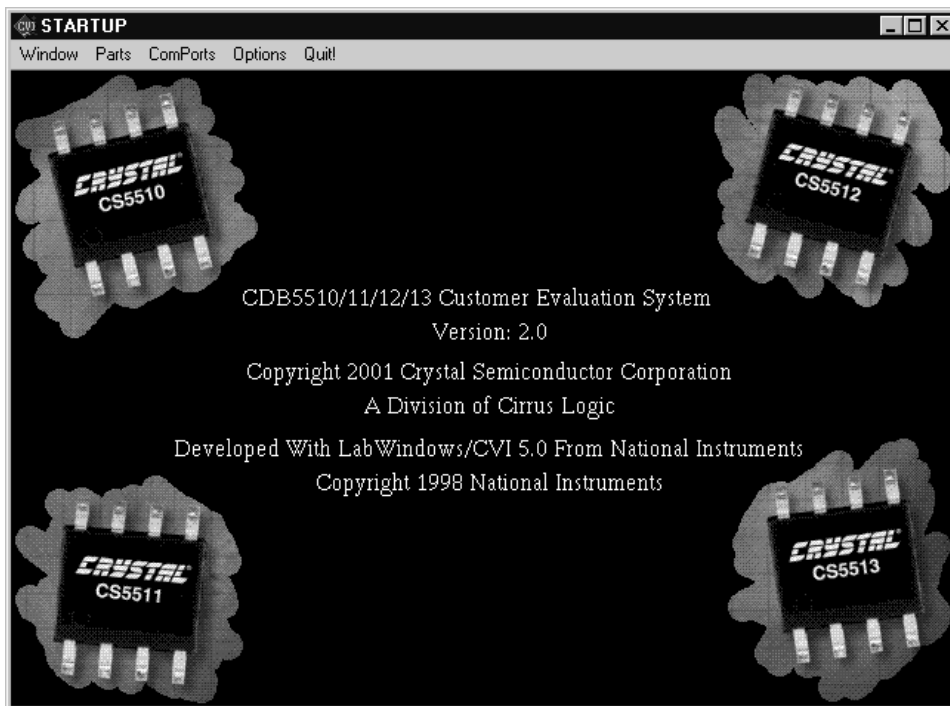

Figure 1. Title Screen

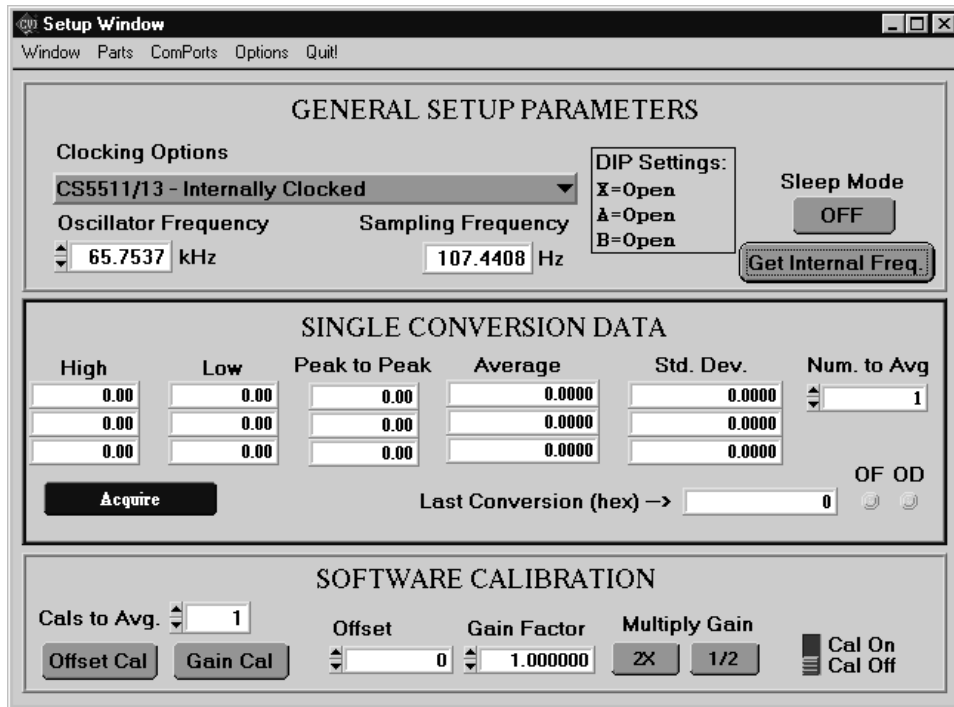

Figure 2. Setup Window

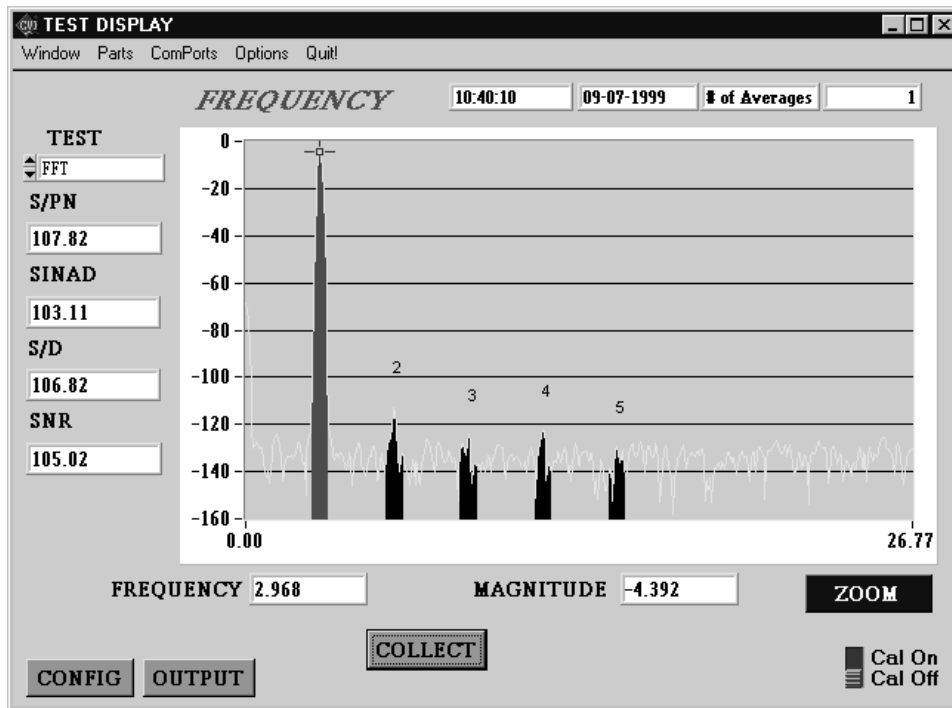

Figure 3. Frequency Domain Analysis

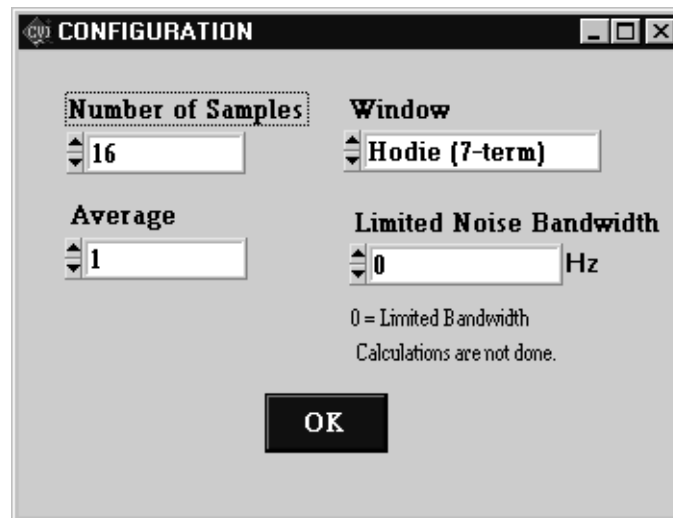

Figure 4. Configuration Panel

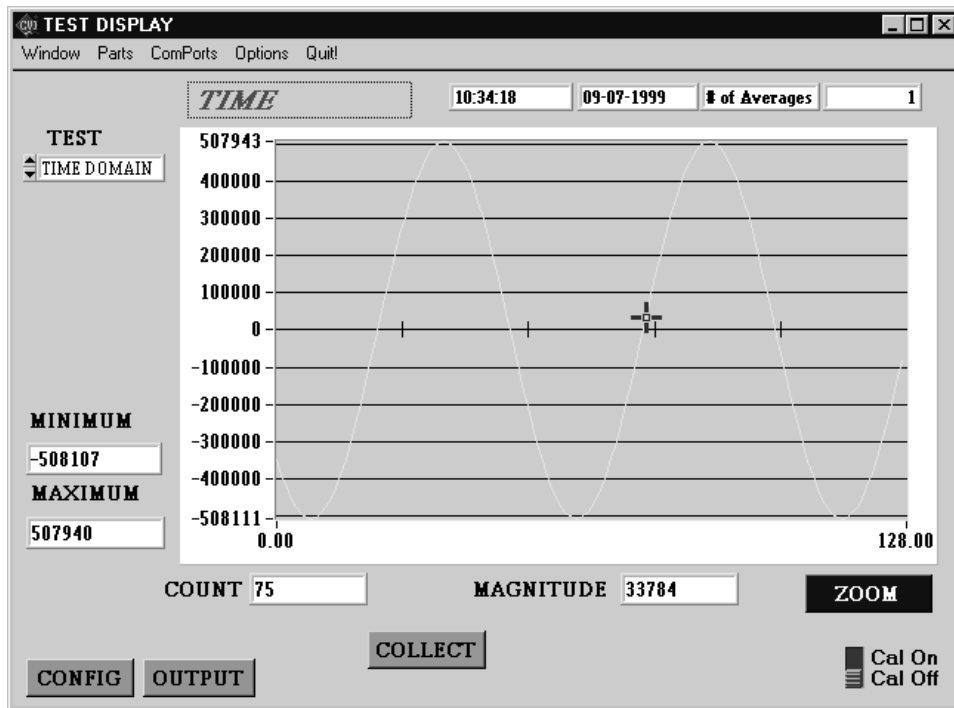

Figure 5. Time Domain Analysis

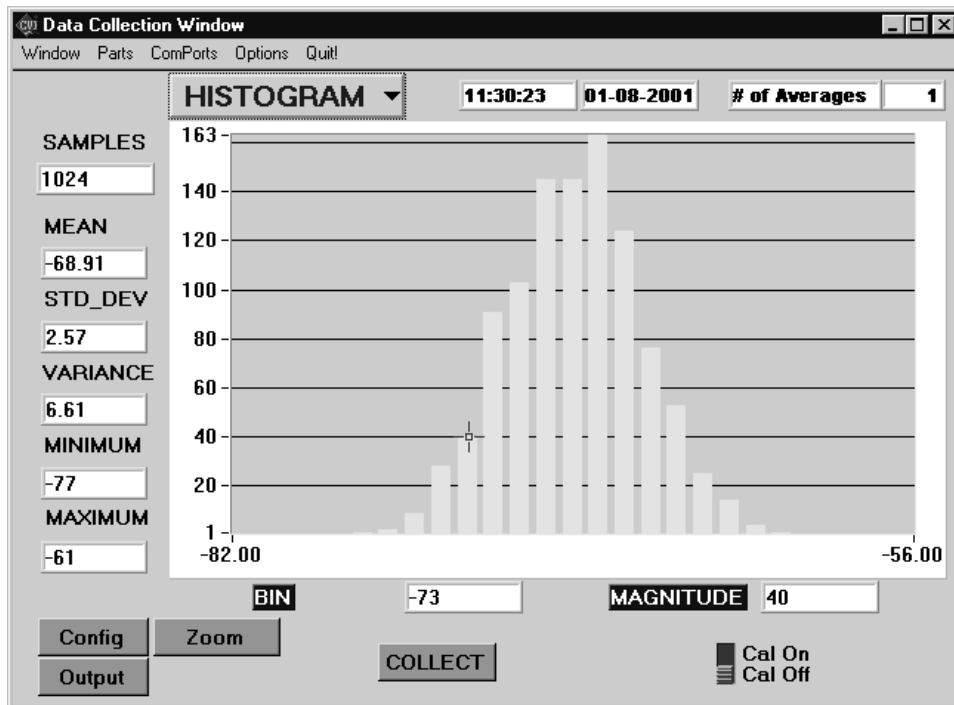
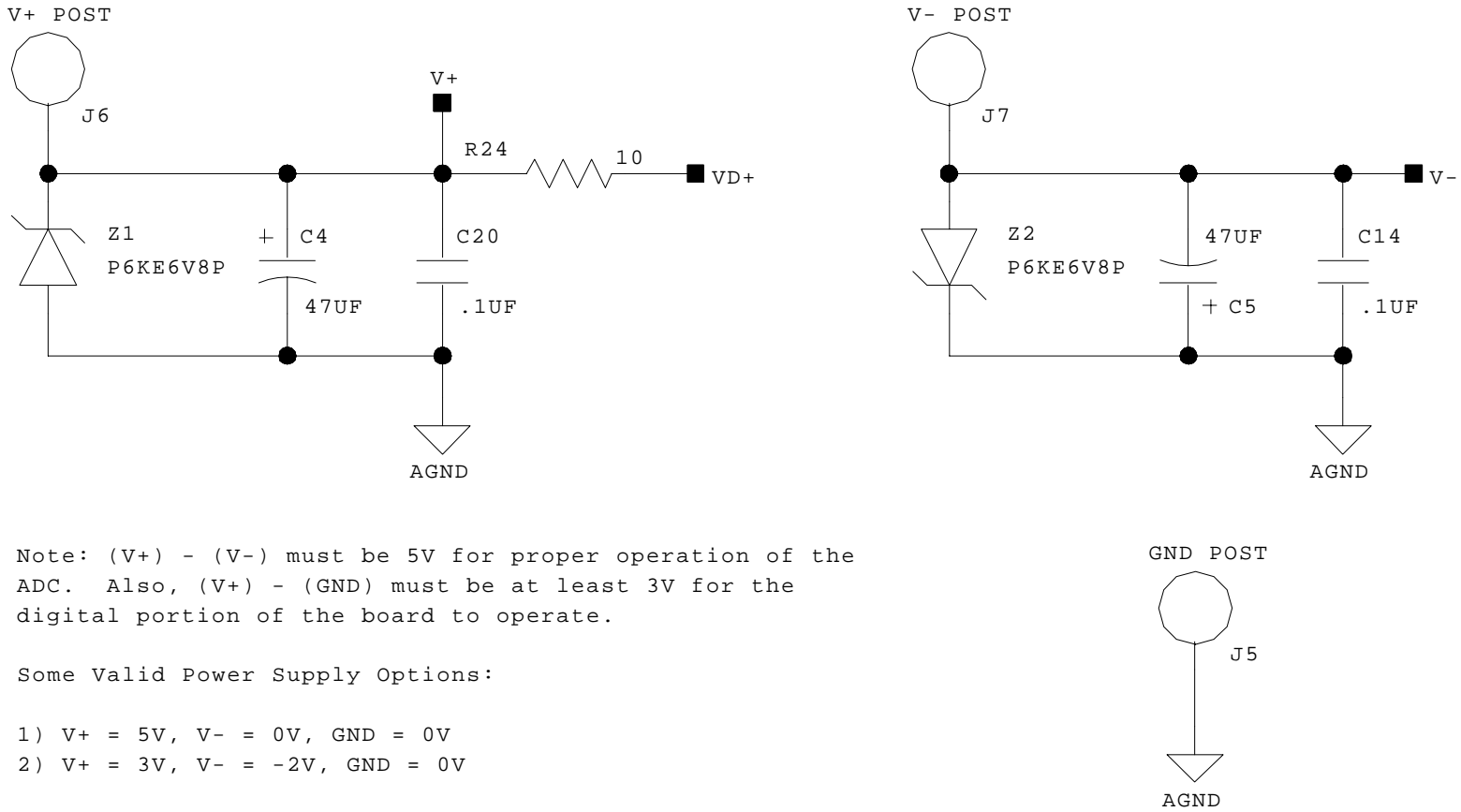

Figure 6. Histogram Analysis



3. SCHEMATICS



Note: (V+) - (V-) must be 5V for proper operation of the ADC. Also, (V+) - (GND) must be at least 3V for the digital portion of the board to operate.

Some Valid Power Supply Options:

- 1) V+ = 5V, V- = 0V, GND = 0V
- 2) V+ = 3V, V- = -2V, GND = 0V

Figure 7. CDB5510 Power Supply Schematic

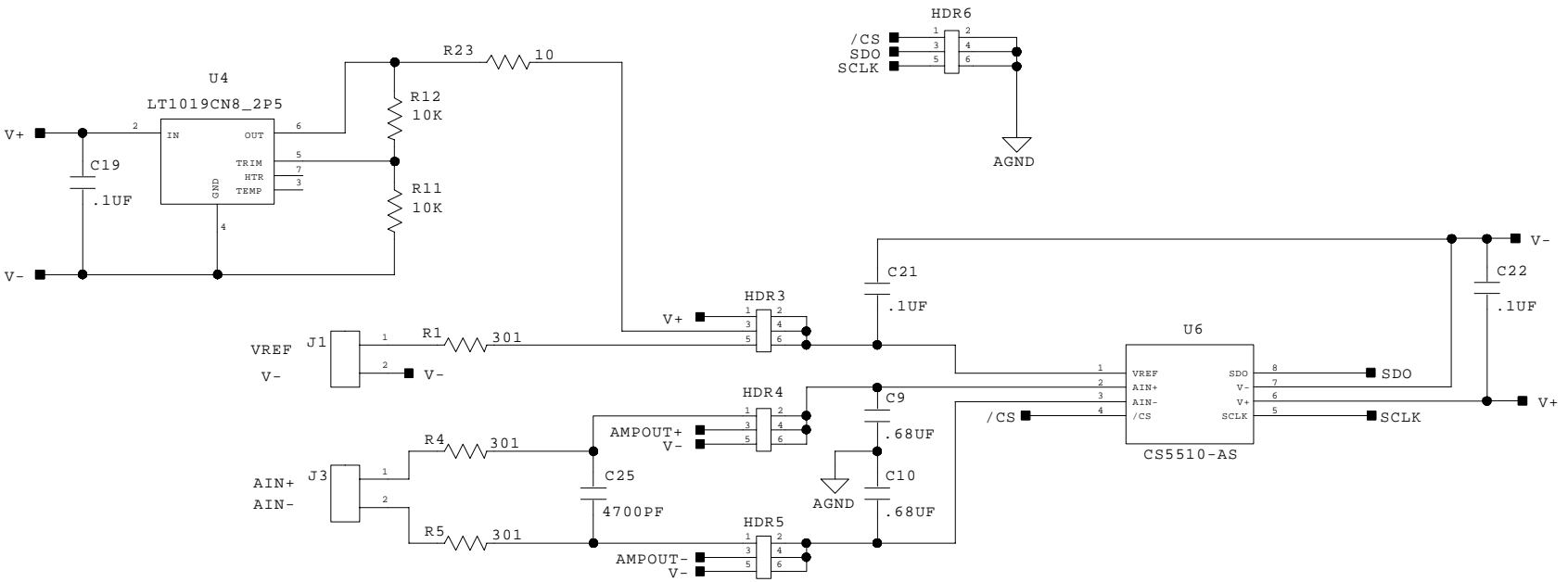

Figure 8. CDB5510 Reference and ADC Schematic

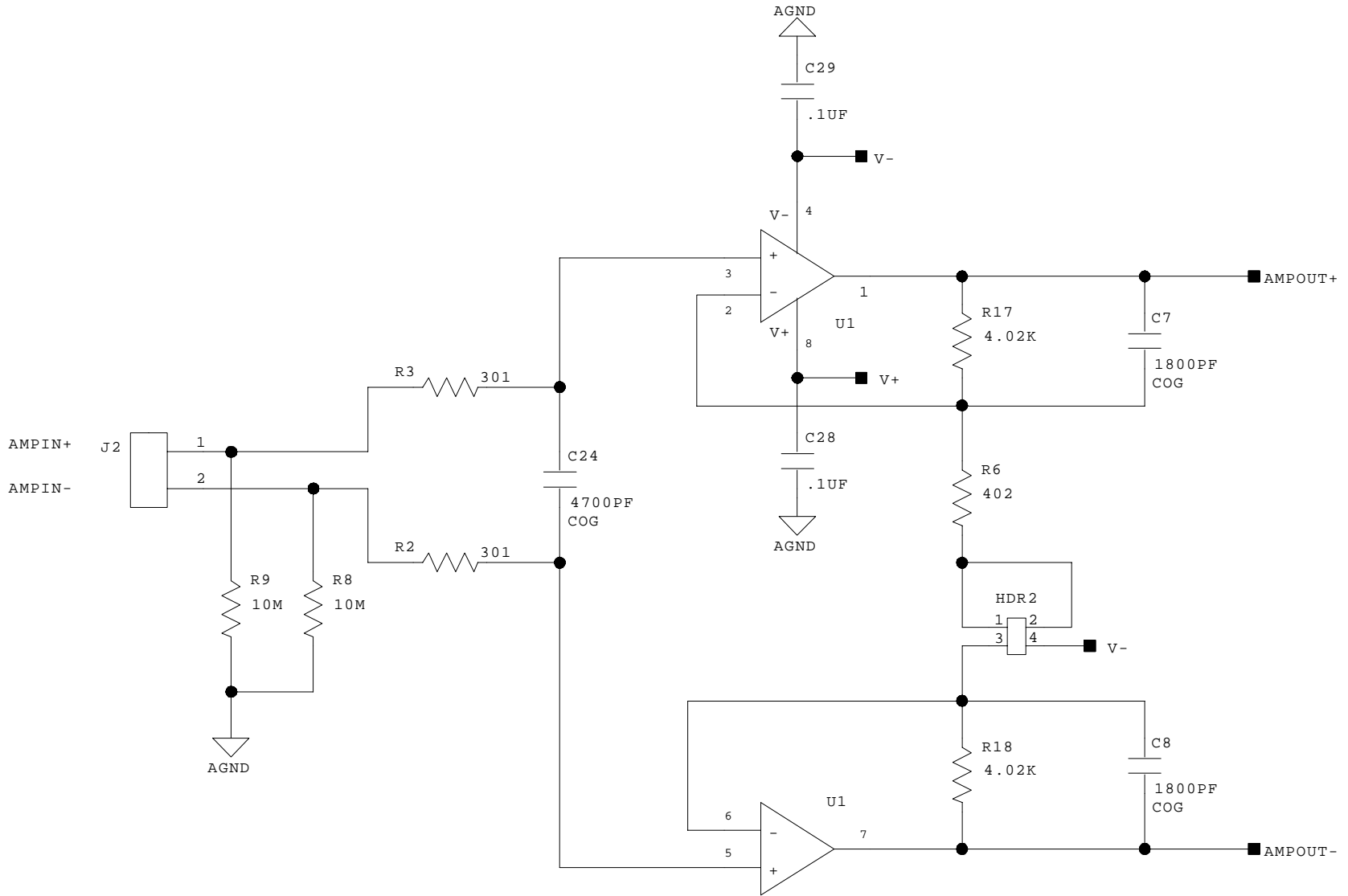

Figure 9. CDB5510 Amplifier Schematic (not populated)

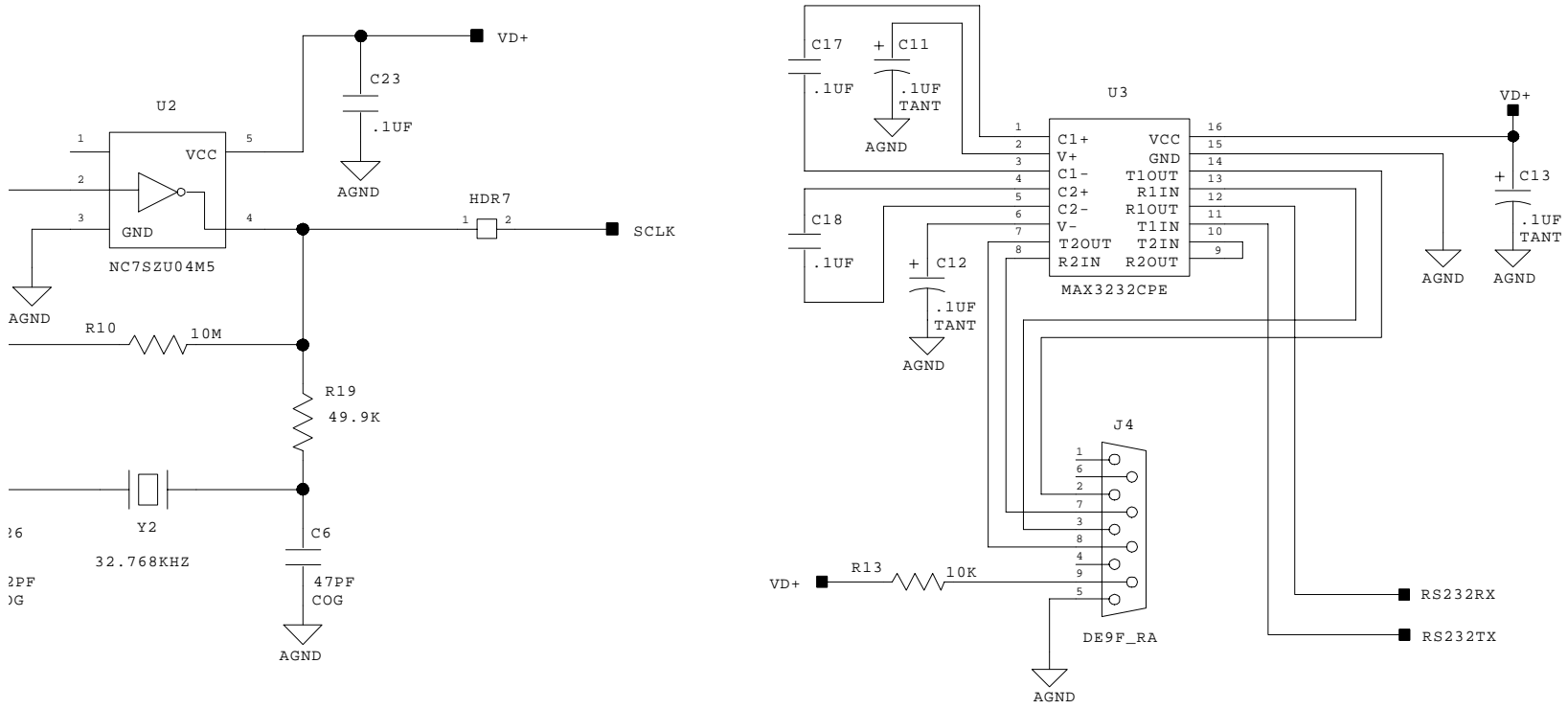

Figure 11. CDB5510 RS232 and Oscillator Schematic



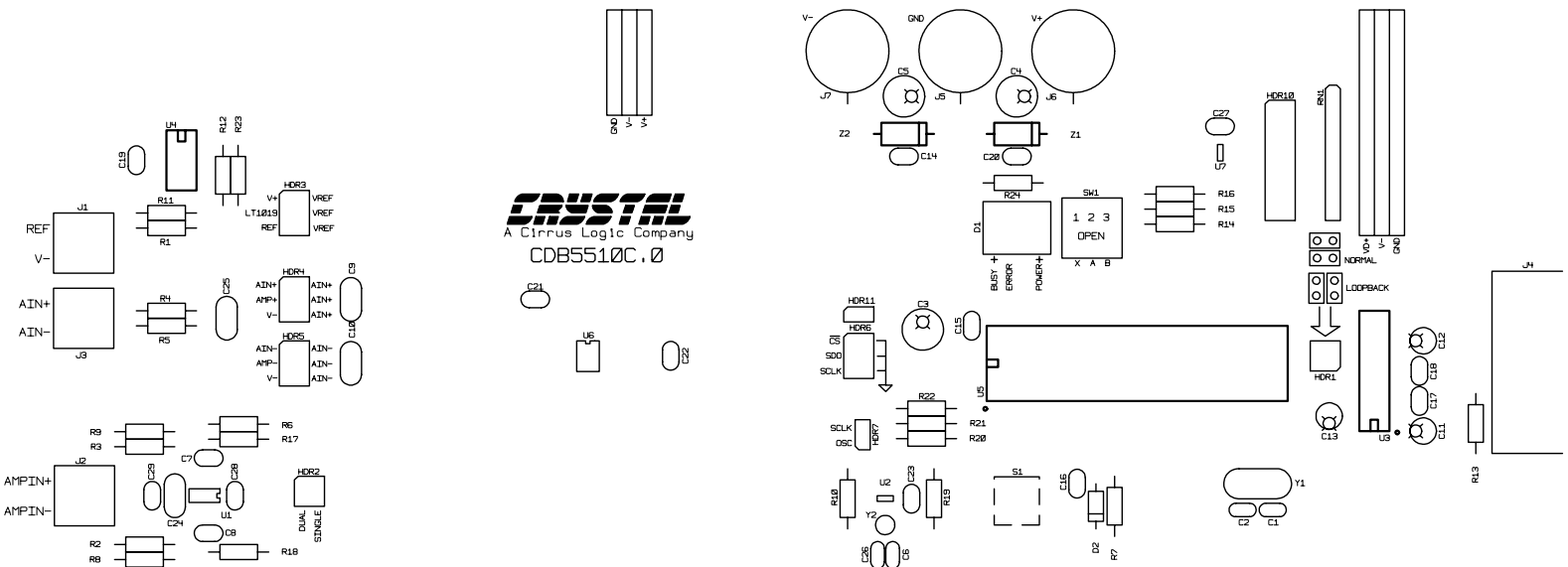
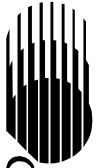

Figure 12. CDB5510 Silkscreen Layout

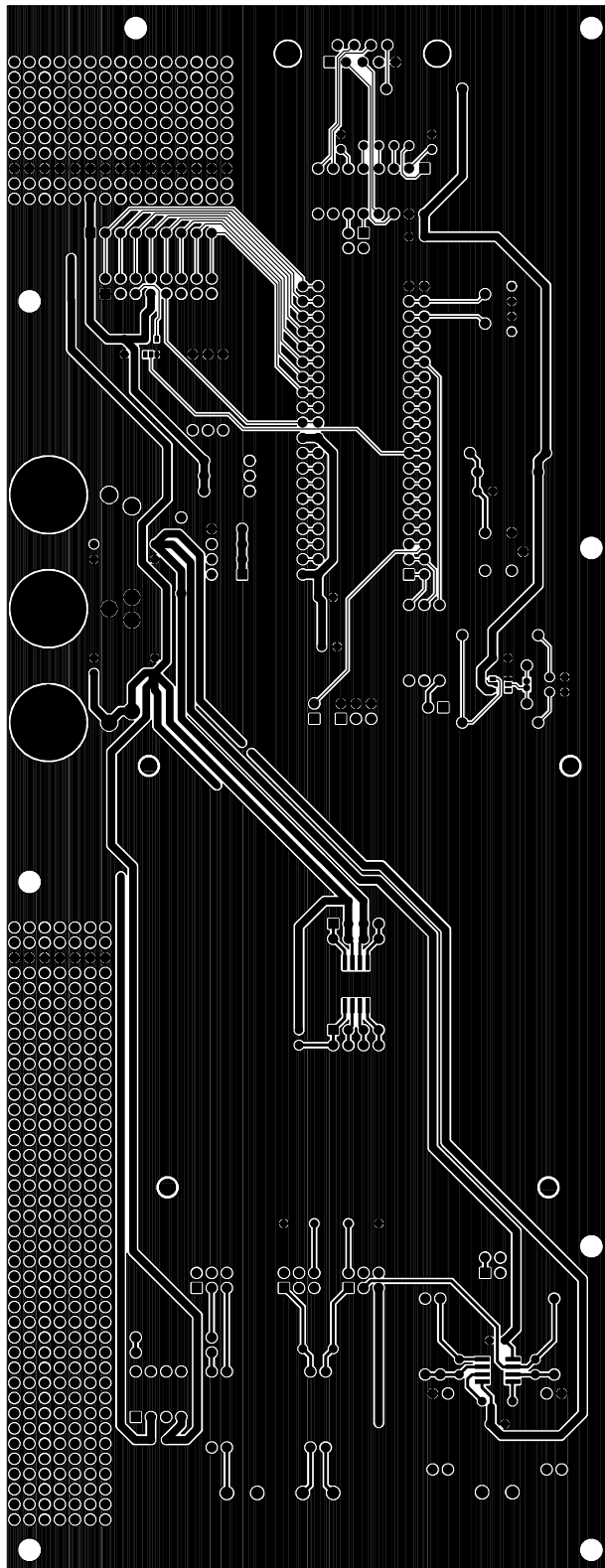

Figure 13. CDB5510 Top Side Layout

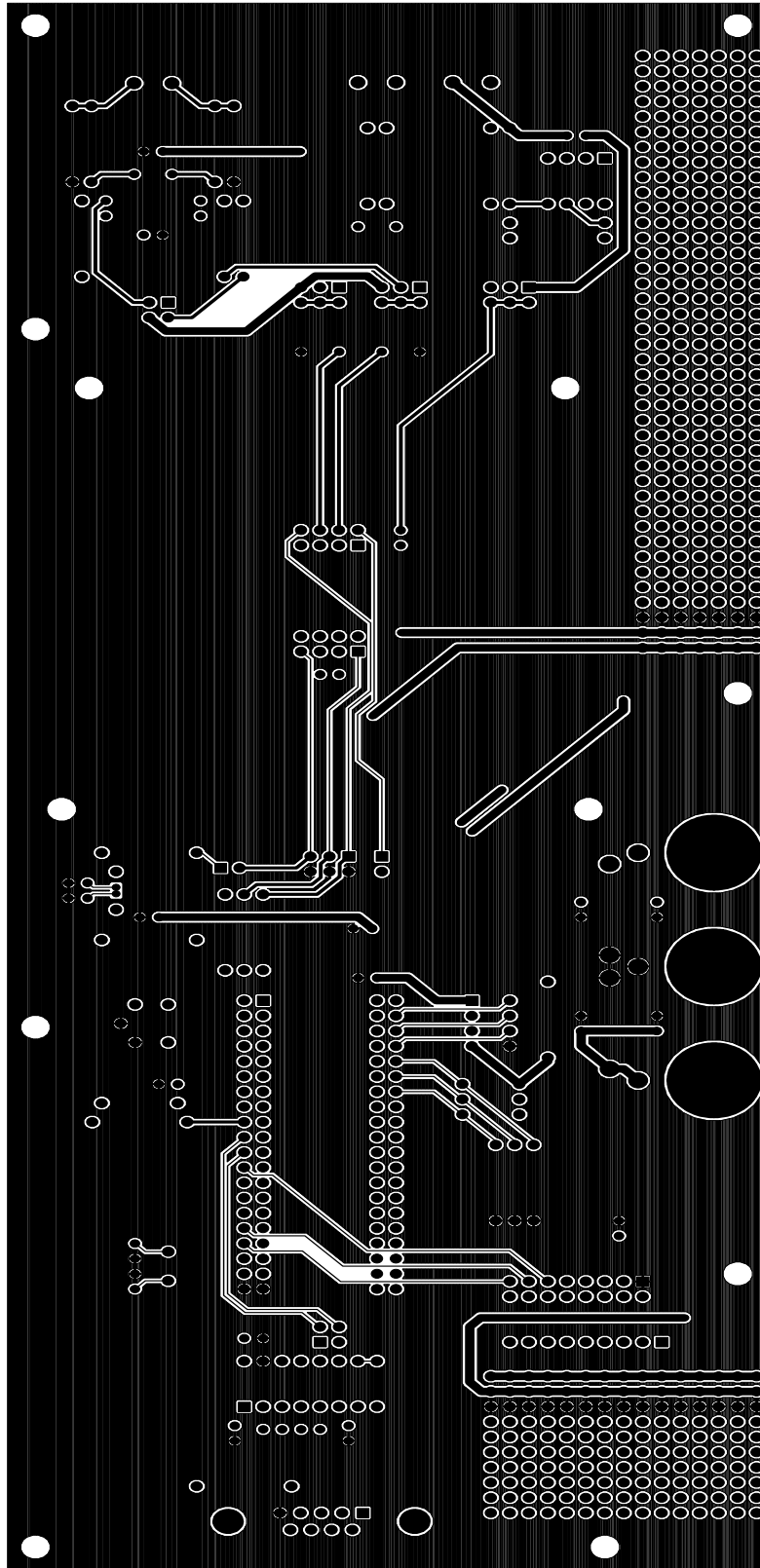
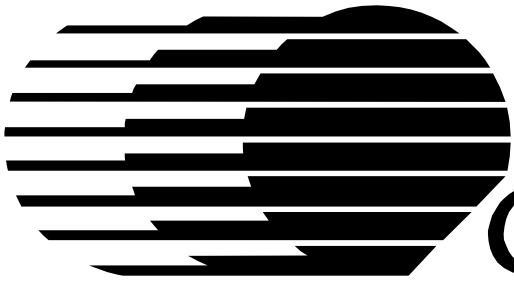

Figure 14. CDB5510 Bottom Side Layout



CIRRUS LOGIC[®]



LittleDiode supplies new, hard to find or obsolete electronic components and semiconductors all over the world.

With over two million different components listed you are sure to find the part you need.

Feel free to visit us today at our online store:

LittleDiode.com

Looking forward to providing you with the best possible service.