



12V, 5V Low Dropout Dual Regulator with ENABLE

Description

The CS8156 is a low dropout 12V/5V dual output linear regulator. The 12V $\pm 5\%$ output sources 750mA and the 5V $\pm 2.0\%$ output sources 100mA.

The on board ENABLE function controls the regulator's two outputs. When the ENABLE lead is low, the regulator is placed in SLEEP mode. Both outputs are disabled and the regulator draws only 200nA of quiescent current.

The regulator is protected against over-voltage conditions. Both outputs are protected against short circuit and thermal runaway conditions.

The CS8156 is packaged in a 5 lead TO-220 with copper tab. The copper tab can be connected to a heat sink if necessary.

Features

- Two regulated outputs
 - 12V $\pm 5.0\%$; 750mA
 - 5V $\pm 2.0\%$; 100mA
- Very low SLEEP mode current drain 200nA
- Fault Protection
 - Reverse Battery
 - +60V, -50V Peak Transient Voltage
 - Short Circuit
 - Thermal Shutdown
- CMOS Compatible ENABLE

Absolute Maximum Ratings

Input Voltage

Operating Range-0.5V to 26V

Peak Transient Voltage (Load Dump = 46V)60V

Internal Power DissipationInternally Limited

Operating Temperature Range.....-40°C to +125°C

Junction Temperature Range.....-40°C to +150°C

Storage Temperature Range-65°C to +150°C

Lead Temperature Soldering

Wave Solder (through hole styles only).....10 sec. max, 260°C peak

Block Diagram

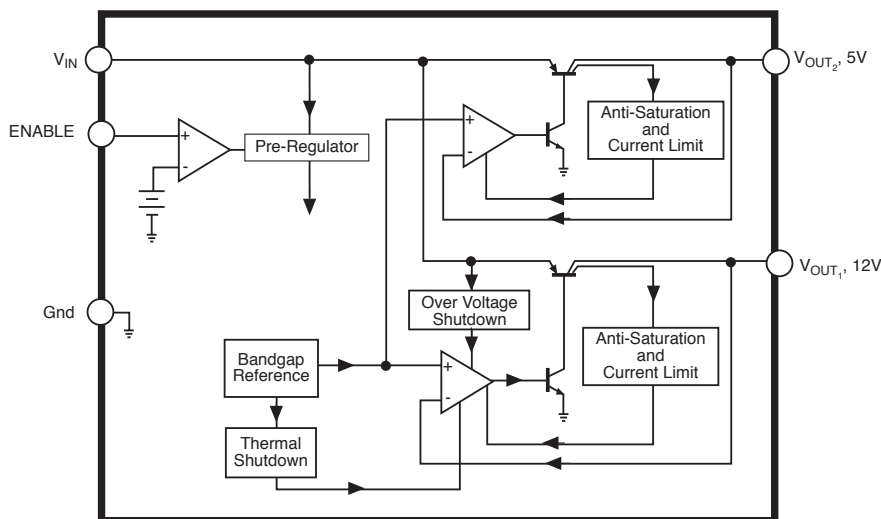

Package Options

5 Lead TO-220

Tab (Gnd)

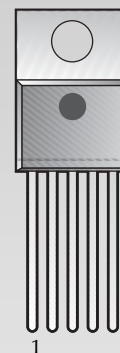

- 1 V_{IN}
- 2 V_{OUT1}
- 3 Gnd
- 4 ENABLE
- 5 V_{OUT2}



Cherry Semiconductor Corporation
 2000 South County Trail, East Greenwich, RI 02818
 Tel: (401)885-3600 Fax: (401)885-5786
 Email: info@cherry-semi.com
 Web Site: www.cherry-semi.com

Electrical Characteristics for V_{OUT} : $V_{IN} = 14.5V$, $I_{OUT1} = 5mA$, $I_{OUT2} = 5mA$, $-40^{\circ}C \leq T_J \leq +150^{\circ}C$, $-40^{\circ}C \leq T_C \leq +125^{\circ}C$ unless otherwise specified

PARAMETER	TEST CONDITIONS	MIN	TYP	MAX	UNIT
■ Output Stage(V_{OUT1})					
Output Voltage, V_{OUT1}	$13V \leq V_{IN} \leq 16V$, $I_{OUT1} \leq 750mA$	11.2	12.0	12.8	V
Dropout Voltage	$I_{OUT1} = 500mA$		0.4	0.6	V
	$I_{OUT1} = 750mA$		0.6	1.0	V
Line Regulation	$13V \leq V_{IN} \leq 16V$, $5mA \leq I_{OUT} < 100mA$		15	80	mV
Load Regulation	$5mA \leq I_{OUT1} \leq 500mA$		15	80	mV
Quiescent Current	$I_{OUT1} \leq 500mA$, No Load on Standby		45	125	mA
	$I_{OUT1} \leq 750mA$, No Load on Standby		100	250	mA
Sleep Mode	ENABLE = Low		200		nA
Ripple Rejection	$f = 120Hz$, $I_{OUT} = 5mA$, $V_{IN} = 1.5V_{PP}$ at $15.5V_{DC}$	42	70		dB
Current Limit		0.75	1.20	2.50	A
Maximum Line Transient	$V_{OUT1} \leq 13V$	60	90		V
Reverse Polarity Input Voltage, DC	$V_{OUT1} \geq -0.6V$, 10Ω Load	-18	-30		V
Reverse Polarity Input Voltage, Transient	1% Duty Cycle, $t = 100ms$, $V_{OUT} \geq -6V$, 10Ω Load	-50	-80		V
Output Noise Voltage	10Hz - 100kHz			500	μV_{rms}
Output Impedance	500mA DC and 10mA rms, 100Hz		0.2	1.0	Ω
Over-voltage Shutdown		28	34	45	V

■ Standby Output (V_{OUT2})

Output Voltage, (V_{OUT2})	$9V \leq V_{IN} \leq 16V$, $1mA \leq I_{OUT2} \leq 100mA$	4.90	5.00	5.10	V
Dropout Voltage	$I_{OUT2} \leq 100mA$			0.60	V
Line Regulation	$6V \leq V_{IN} \leq 26V$; $1mA \leq I_{OUT} \leq 100mA$		5	50	mV
Load Regulation	$1mA \leq I_{OUT2} \leq 100mA$; $9V \leq V_{IN} \leq 16V$		5	50	mV
Quiescent Current	V_{OUT1} OFF, V_{OUT2} OFF, $V_{ENABLE} = 0.8V$		1	350	μA
Ripple Rejection	$f = 120Hz$; $I_{OUT} = 100mA$, $V_{IN} = 1.5V_{PP}$ at $14.5V_{DC}$	42	70		dB
Current Limit		100	200		mA

■ ENABLE Function (ENABLE)

Input ENABLE Threshold	V_{OUT1} Off		1.25	0.80	V
	V_{OUT1} On	2.00	1.25		V
Input ENABLE Current	$V_{ENABLE} \leq V_{THRESHOLD}$	-10	0	10	μA

Package Lead Description

PACKAGE LEAD #	LEAD SYMBOL	FUNCTION
5 Lead TO-220		
1	V_{IN}	Supply voltage, usually direct from battery.
2	V_{OUT1}	Regulated output 12V, 750mA (typ)
3	Gnd	Ground connection.
4	ENABLE	CMOS compatible input lead; switches outputs on and off. When ENABLE is high V_{OUT1} and V_{OUT2} are active.
5	V_{OUT2}	Regulated output 5V, 100mA (typ).

Dropout Voltage vs I_{OUT2}

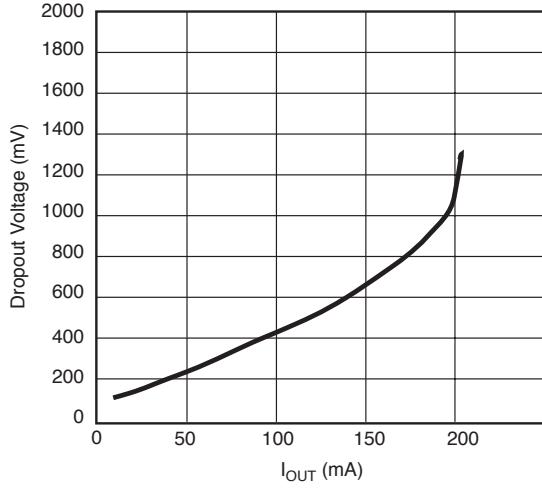

V_{OUT1} vs. Input Voltage

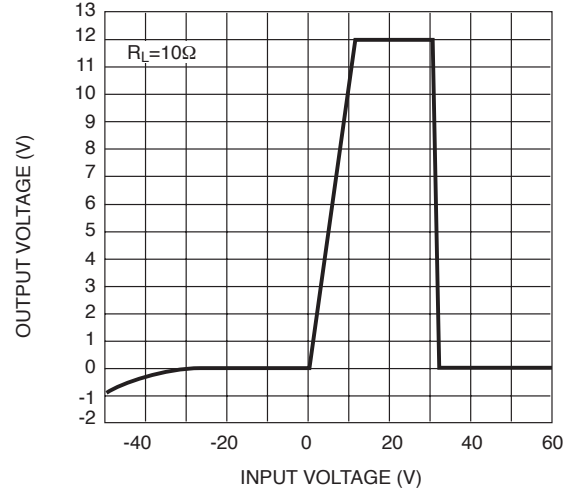

V_{OUT1} vs. Temperature

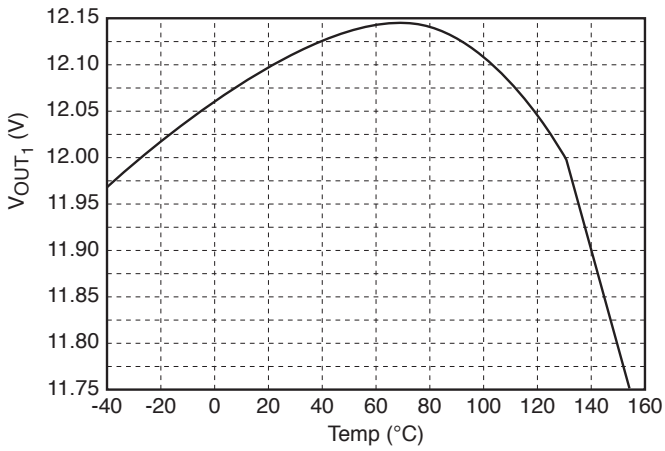

V_{OUT2} vs. Temperature

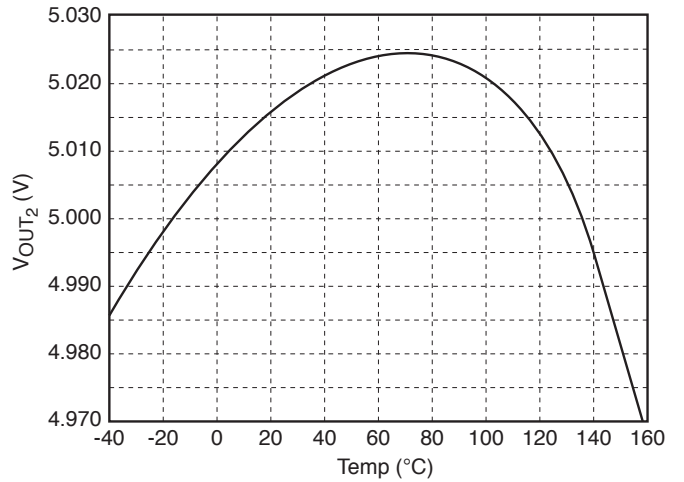

ENABLE Current vs. ENABLE Voltage

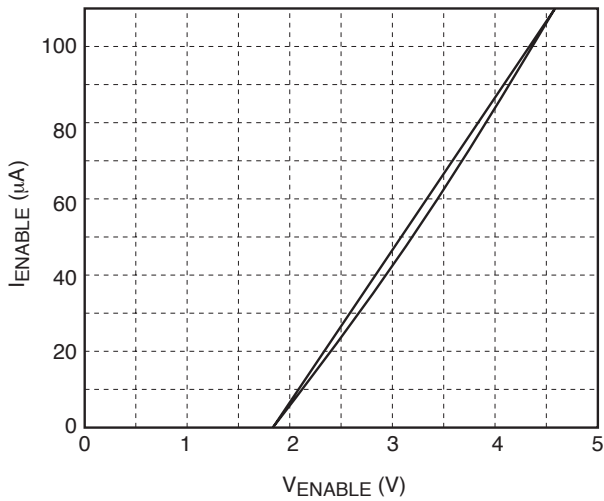

ENABLE Current vs. ENABLE Voltage

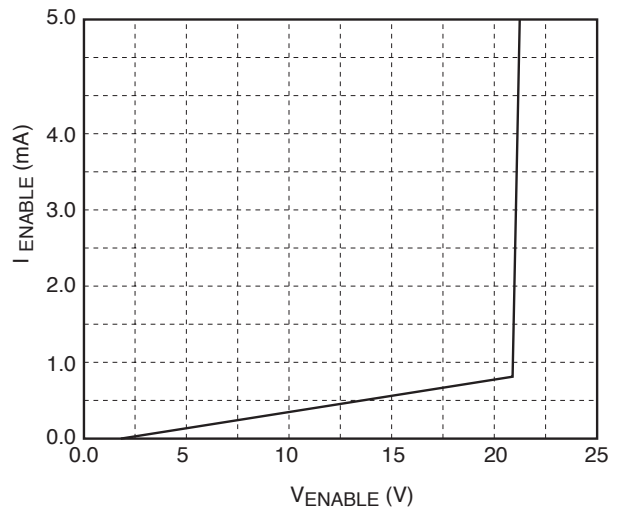

Typical Performance Characteristics: continued

Line Transient Response (V_{OUT1})

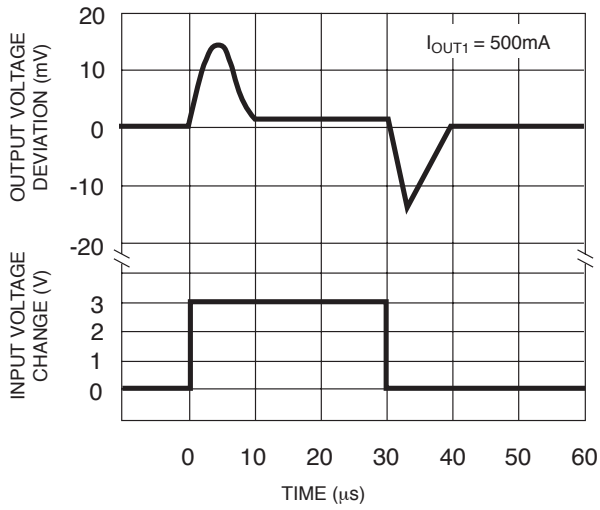

Line Transient Response (V_{OUT2})

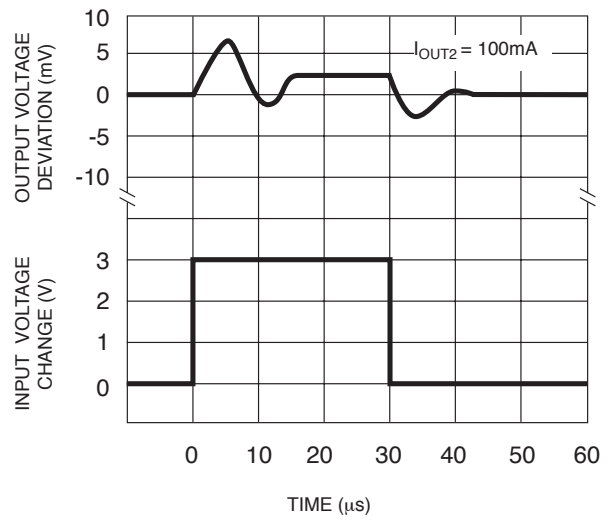

Load Transient Response (V_{OUT1})

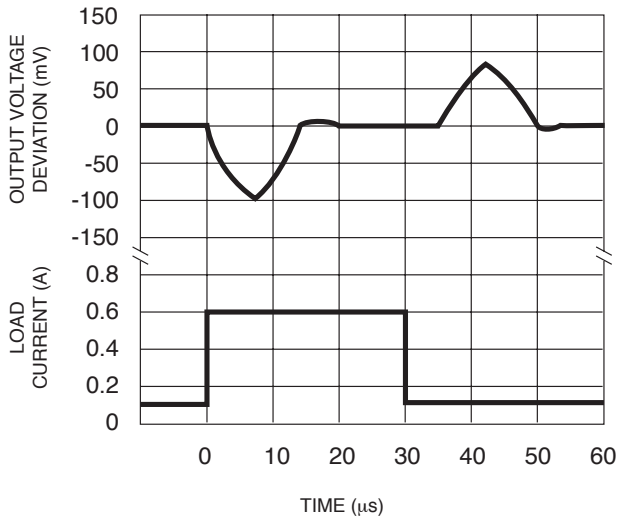

Load Transient Response (V_{OUT2})

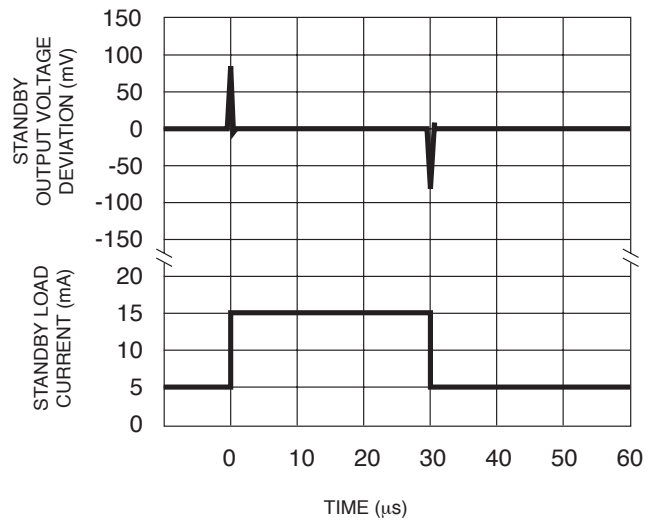

Maximum Power Dissipation (TO-220)

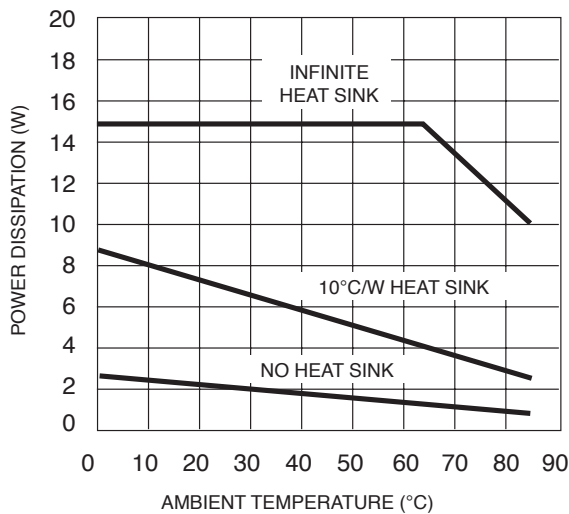

Quiescent Current vs Output Current for V_{OUT2}

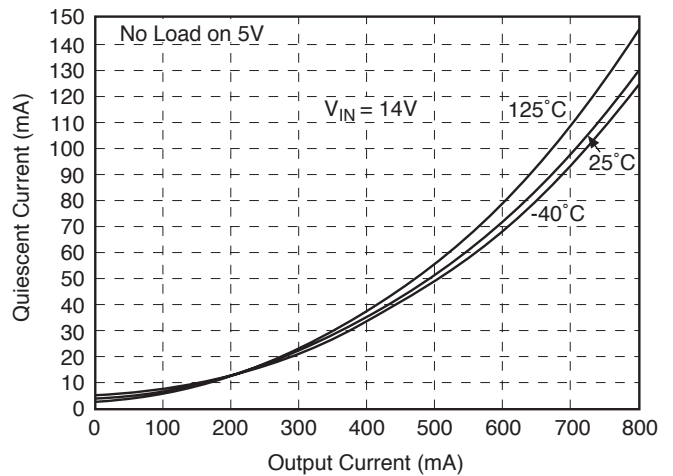

Quiescent Current vs Output Current for V_{OUT1}

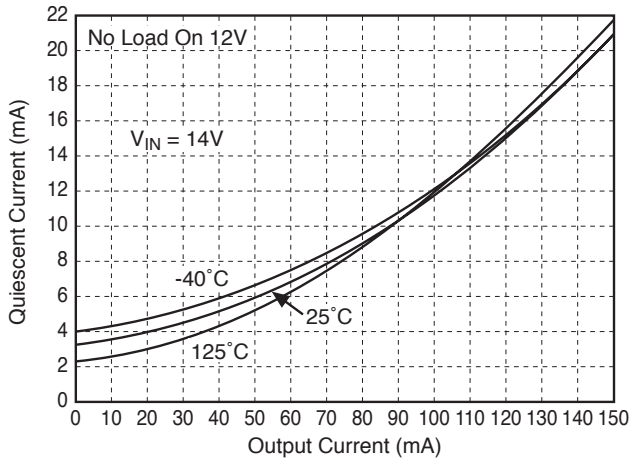

Line Regulation vs Output Current for V_{OUT2}

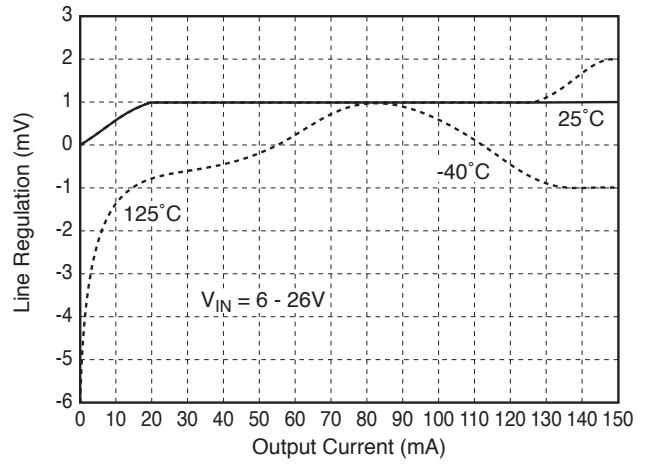

Load Regulation vs Output Current for V_{OUT2}

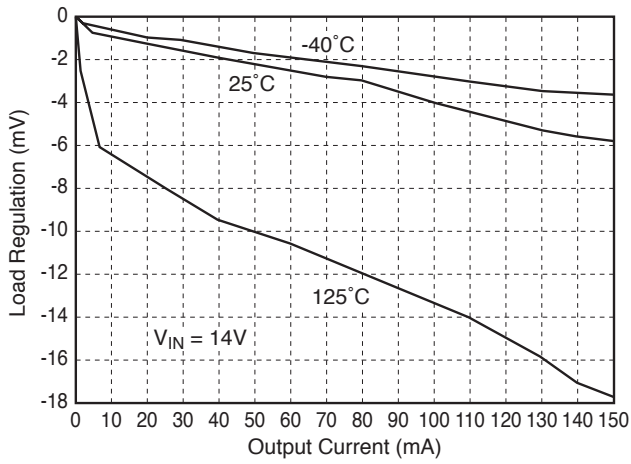

Line Regulation vs Output Current for V_{OUT1}

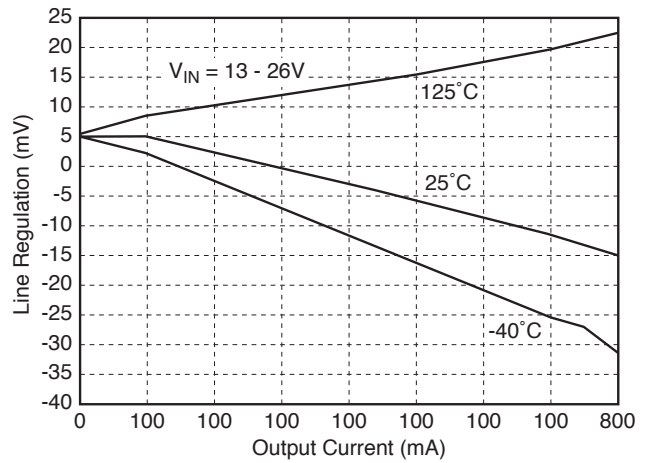

Load Regulation vs Output Current for V_{OUT1}

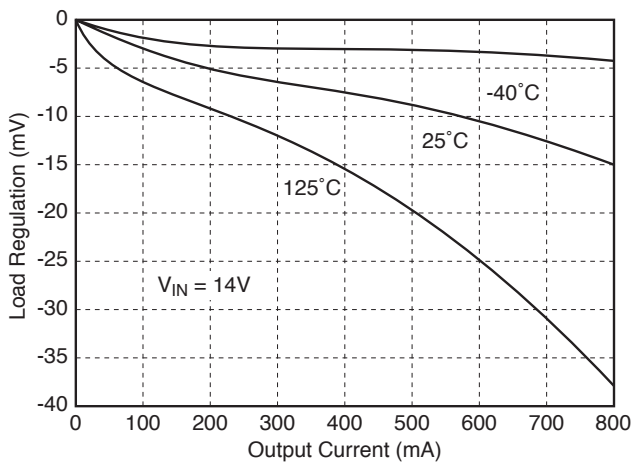

Dropout Voltage

The input-output voltage differential at which the circuit ceases to regulate against further reduction in input voltage. Measured when the output voltage has dropped 100mV from the nominal value obtained at 14V input, dropout voltage is dependent upon load current and junction temperature.

Input Voltage

The DC voltage applied to the input terminals with respect to ground.

Input Output Differential

The voltage difference between the unregulated input voltage and the regulated output voltage for which the regulator will operate.

Line Regulation

The change in output voltage for a change in the input voltage. The measurement is made under conditions of low dissipation or by using pulse techniques such that the average chip temperature is not significantly affected.

Load Regulation

The change in output voltage for a change in load current at constant chip temperature.

Long Term Stability

Output voltage stability under accelerated life-test conditions after 1000 hours with maximum rated voltage and junction temperature.

Output Noise Voltages

The rms AC voltage at the output, with constant load and no input ripple, measured over a specified frequency range.

Quiescent Current

The part of the positive input current that does not contribute to the positive load current. i.e., the regulator ground lead current.

Ripple Rejection

The ratio of the peak-to-peak input ripple voltage to the peak-to-peak output ripple voltage.

Temperature Stability of V_{OUT}

The percentage change in output voltage for a thermal variation from room temperature to either temperature extreme.

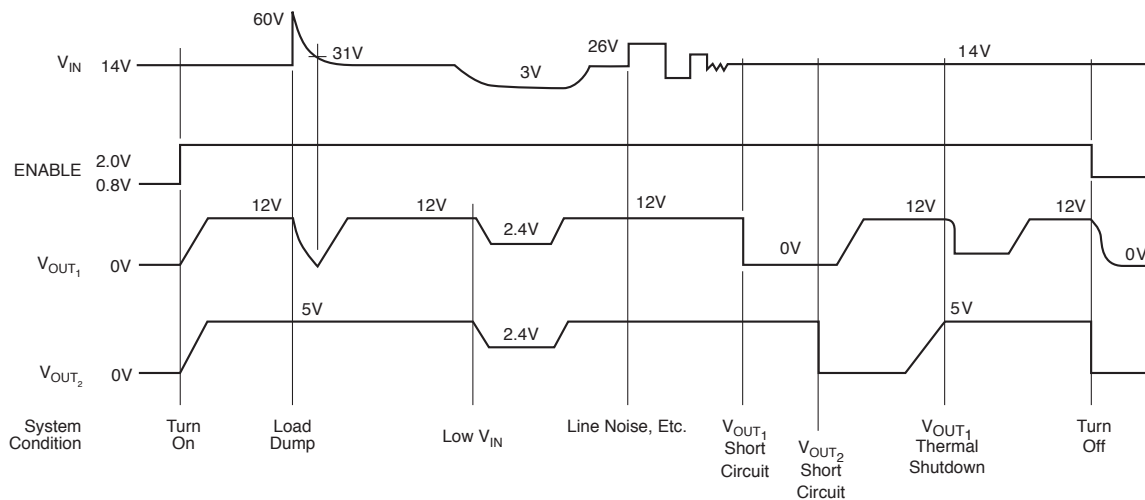
Typical Circuit Waveform**Application Notes****Stability Considerations**

The output or compensation capacitor helps determine three main characteristics of a linear regulator: start-up delay, load transient response and loop stability.

The capacitor value and type should be based on cost, availability, size and temperature constraints. A tantalum or aluminum electrolytic capacitor is best, since a film or ceramic capacitor with almost zero ESR can cause instability. The aluminum electrolytic capacitor is the cheapest solution, but, if the circuit operates at low temperatures (-25°C to -40°C), both the value and ESR of the capacitor will vary considerably. The capacitor manufacturers data sheet usually provides this information.

The value for the output capacitors C2 and C3 shown in the test and applications circuit should work for most applications, however it is not necessarily the best solution.

To determine acceptable values for C2 and C3 for a particular application, start with a tantalum capacitor of the recommended value and work towards a less expensive alternative part for each output.

Step 1: Place the completed circuit with the tantalum capacitors of the recommended value in an environmental chamber at the lowest specified operating temperature and monitor the outputs with an oscilloscope. A decade box connected in series with capacitor C₂ will simulate the higher ESR of an aluminum capacitor. Leave the decade box outside the chamber, the small resistance added by the longer leads is negligible.

Step 2: With the input voltage at its maximum value, increase the load current slowly from zero to full load on the output under observation. Look for any oscillations on the output. If no oscillations are observed, the capacitor is large enough to ensure a stable design under steady state conditions.

Step 3: Increase the ESR of the capacitor from zero using the decade box and vary the load current until oscillations appear. Record the values of load current and ESR that cause the greatest oscillation. This represents the worst case load conditions for the output at low temperature.

Step 4: Maintain the worst case load conditions set in step 3 and vary the input voltage until the oscillations increase. This point represents the worst case input voltage conditions.

Step 5: If the capacitor is adequate, repeat steps 3 and 4 with the next smaller valued capacitor. A smaller capacitor will usually cost less and occupy less board space. If the output oscillates within the range of expected operating conditions, repeat steps 3 and 4 with the next larger standard capacitor value.

Step 6: Test the load transient response by switching in various loads at several frequencies to simulate its real working environment. Vary the ESR to reduce ringing.

Step 7: Remove the unit from the environmental chamber and heat the IC with a heat gun. Vary the load current as instructed in step 5 to test for any oscillations.

Once the minimum capacitor value with the maximum ESR is found for each output, a safety factor should be added to allow for the tolerance of the capacitor and any variations in regulator performance. Most good quality aluminum electrolytic capacitors have a tolerance of +/- 20% so the minimum value found should be increased by at least 50% to allow for this tolerance plus the variation which will occur at low temperatures. The ESR of the capacitors should be less than 50% of the maximum allowable ESR found in step 3 above.

Repeat steps 1 through 7 with C₃, the capacitor on the other output.

Calculating Power Dissipation in a Dual Output Linear Regulator

The maximum power dissipation for a dual output regulator (Figure 1) is:

$$P_{D(max)} = \{V_{IN(max)} - V_{OUT1(min)}\}I_{OUT1(max)} + \{V_{IN(max)} - V_{OUT2(min)}\}I_{OUT2(max)} + V_{IN(max)}I_Q \quad (1)$$

Where:

V_{IN(max)} is the maximum input voltage,

V_{OUT1(min)} is the minimum output voltage from V_{OUT1},

V_{OUT2(min)} is the minimum output voltage from V_{OUT2},

I_{OUT1(max)} is the maximum output current for the application,

I_{OUT2(max)} is the maximum output current for the application, and

I_Q is the quiescent current the regulator consumes at I_{OUT(max)}.

Once the value of P_{D(max)} is known, the maximum permissible value of R_{θJA} can be calculated:

$$R_{\theta JA} = \frac{150^{\circ}\text{C} - T_A}{P_D} \quad (2)$$

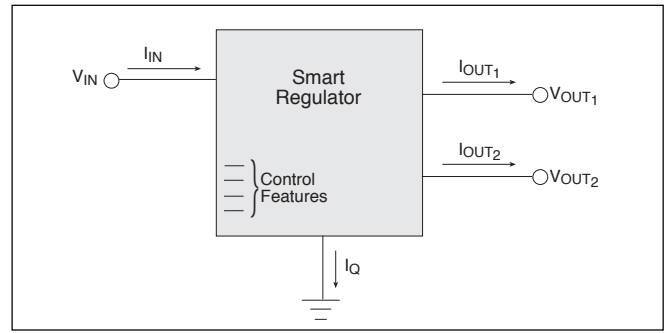

Figure 1: Dual output regulator with key performance parameters labeled.

The value of R_{θJA} can then be compared with those in the package section of the data sheet. Those packages with R_{θJA}'s less than the calculated value in equation 2 will keep the die temperature below 150°C.

In some cases, none of the packages will be sufficient to dissipate the heat generated by the IC, and an external heatsink will be required.

Heat Sinks

A heat sink effectively increases the surface area of the package to improve the flow of heat away from the IC and into the surrounding air.

Each material in the heat flow path between the IC and the outside environment will have a thermal resistance. Like series electrical resistances, these resistances are summed to determine the value of R_{θJA}:

$$R_{\theta JA} = R_{\theta JC} + R_{\theta CS} + R_{\theta SA} \quad (3)$$

where

R_{θJC} = the junction-to-case thermal resistance,

R_{θCS} = the case-to-heatsink thermal resistance, and

R_{θSA} = the heatsink-to-ambient thermal resistance.

R_{θJC} appears in the package section of the data sheet. Like R_{θJA}, it too is a function of package type. R_{θCS} and R_{θSA} are functions of the package type, heatsink and the interface between them. These values appear in heat sink data sheets of heat sink manufacturers.

Test & Application Circuit

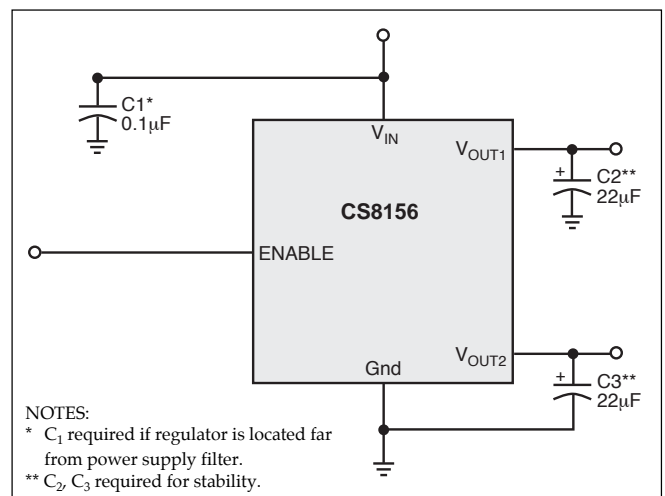

PACKAGE DIMENSIONS IN mm(INCHES)

5 Lead TO-220 (T) Straight

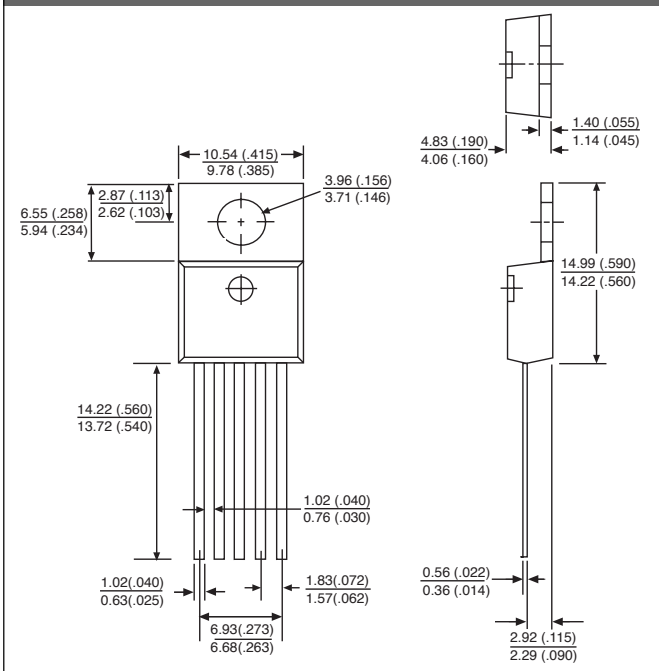

5 Lead TO-220 (TVA) Vertical

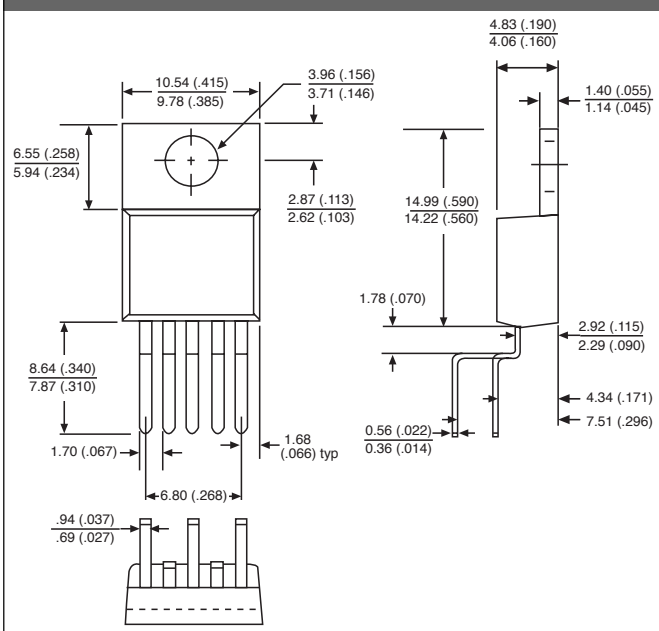

PACKAGE THERMAL DATA

Thermal Data		5 Lead TO-220	
$R_{\theta JC}$	typ	2.0	$^{\circ}C/W$
$R_{\theta JA}$	typ	50	$^{\circ}C/W$

5 Lead TO-220 (THA) Horizontal

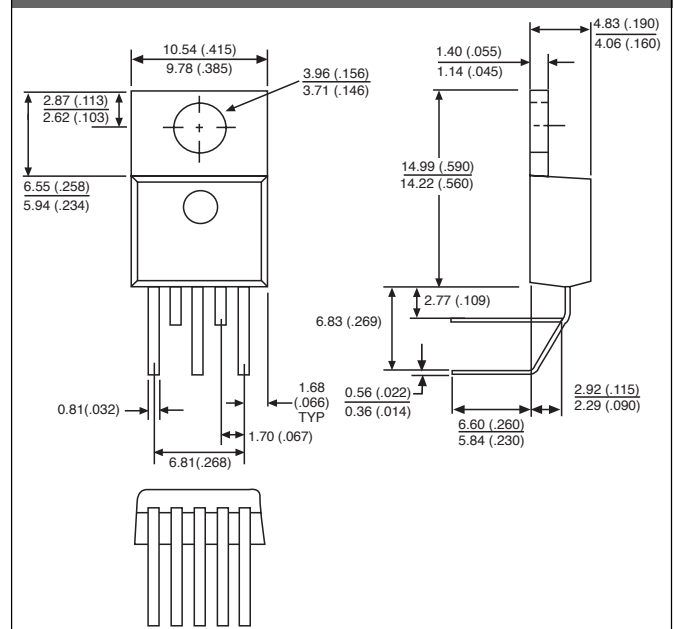

Ordering Information

Part Number	Description
CS8156YT5	5 Lead TO-220 Straight
CS8156YTVA5	5 Lead TO-220 Vertical
CS8156YTHA5	5 Lead TO-220 Horizontal

Cherry Semiconductor Corporation reserves the right to make changes to the specifications without notice. Please contact Cherry Semiconductor Corporation for the latest available information.



LittleDiode supplies new, hard to find or obsolete electronic components and semiconductors all over the world.

With over two million different components listed you are sure to find the part you need.

Feel free to visit us today at our online store:

LittleDiode.com

Looking forward to providing you with the best possible service.