



2.5V - 2.6V PHASE LOCKED LOOP DIFFERENTIAL 1:10 SDRAM CLOCK DRIVER

IDTCSPT857C

FEATURES:

- 1 to 10 differential clock distribution
- Optimized for clock distribution in DDR (Double Data Rate) SDRAM applications
- Operating frequency: 60MHz to 220MHz
- Very low skew:
 - <100ps for PC1600 - PC2700
 - <75ps for PC3200
- Very low jitter:
 - <75ps for PC1600 - PC2700
 - <50ps for PC3200
- 2.5V AV_{DD} and 2.5V V_{DDQ} for PC1600-PC2700
- 2.6V AV_{DD} and 2.6V V_{DDQ} for PC3200
- CMOS control signal input
- Test mode enables buffers while disabling PLL
- Low current power-down mode
- Tolerant of Spread Spectrum input clock
- Available in 48-pin TSSOP and TVSOP, 40-pin VFQFPN, and 56-pin VFBGA packages

APPLICATIONS:

- Meets or exceeds JEDEC standard JESD 82-1A for registered DDR clock driver
- Meets proposed DDR1-400 specification
- For all DDR1 speeds: PC1600 (DDR200), PC2100 (DDR266), PC2700 (DDR333), PC3200 (DDR400)
- Along with SSTV16857, SSTVF16857, SSTV16859, SSTVM16859, SSTVF16859, DDR1 register, provides complete solution for DDR1 DIMMs

DESCRIPTION:

The CSPT857C is a PLL based clock driver that acts as a zero delay buffer to distribute one differential clock input pair (CLK, $\overline{\text{CLK}}$) to 10 differential output pairs (Y_[0:9], $\overline{\text{Y}}_{[0:9]}$) and one differential pair of feedback clock output (FBOUT, $\overline{\text{FBOUT}}$). External feedback pins (FBIN, $\overline{\text{FBIN}}$) for synchronization of the outputs to the input reference is provided. A CMOS Enable/Disable pin is available for low power disable. When the input frequency falls below approximately 20MHz, the device will enter power down mode. In this mode, the receivers are disabled, the PLL is turned off, and the output clock drivers are tristated, resulting in a current consumption of less than 200 μ A.

The CSPT857C requires no external components and has been optimised for very low I/O phase error, skew, and jitter, while maintaining frequency and duty cycle over the operating voltage and temperature range. The CSPT857C, designed for use in both module assemblies and system motherboard based solutions, provides an optimum high-performance clock source.

The CSPT857C is available in Commercial Temperature Range (0°C to +70°C) and Industrial Temperature Range (-40°C to +85°C). See Ordering Information for details.

FUNCTIONAL BLOCK DIAGRAM

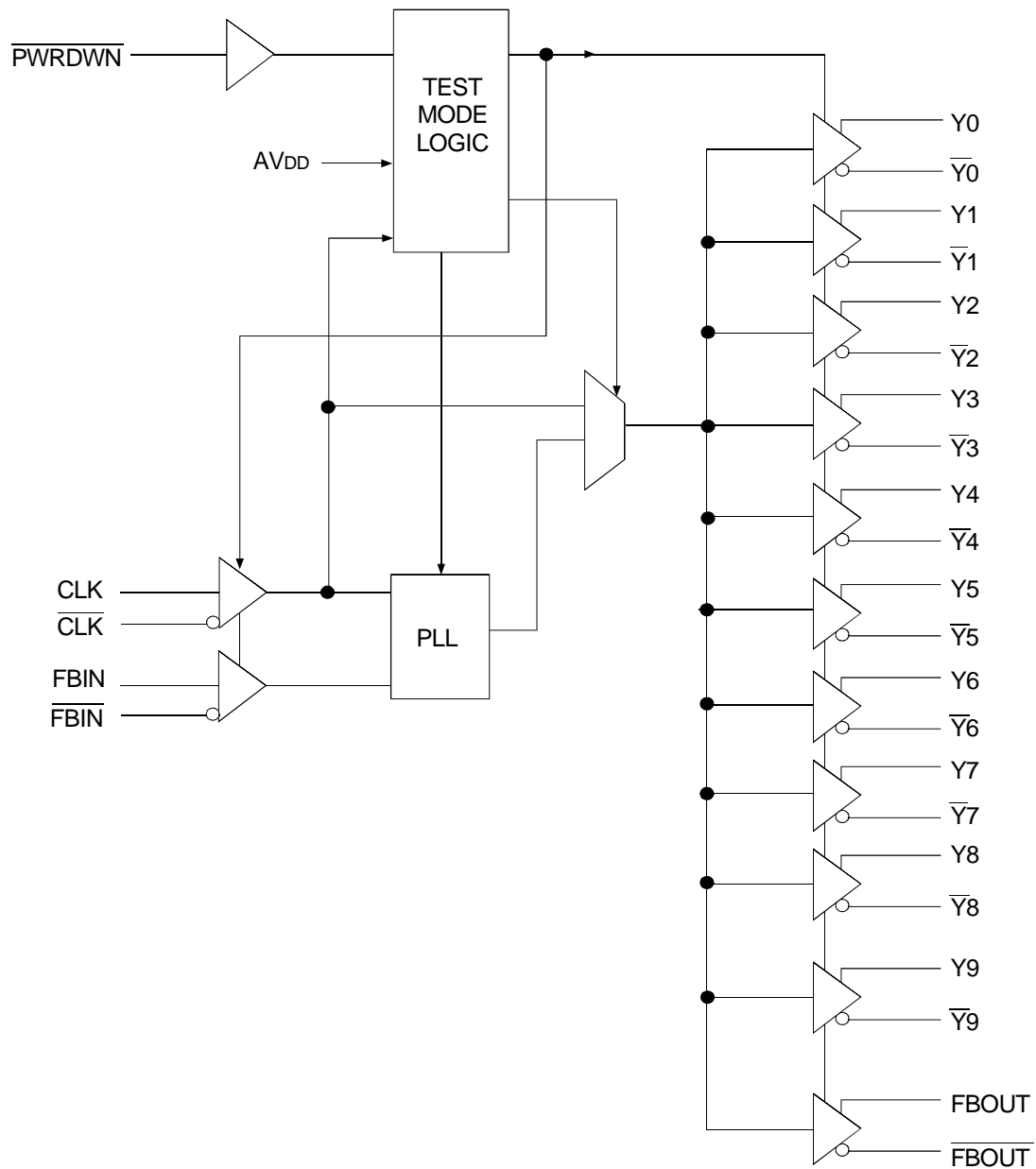

PIN CONFIGURATIONS

6	Y5	$\overline{Y6}$	GND	Y7	$\overline{PWR/DWN}$	FBIN	VDDQ	FBOUT	$\overline{Y8}$	Y9
5	$\overline{Y5}$	Y6	GND	$\overline{Y7}$	VDDQ	\overline{FBIN}	\overline{FBOUT}	GND	Y8	$\overline{Y9}$
4	GND	VDDQ	NC	NC			NC	NC	VDDQ	GND
3	GND	VDDQ	NC	NC			NC	NC	VDDQ	GND
2	$\overline{Y0}$	Y1	GND	$\overline{Y2}$	VDDQ	\overline{CLK}	AVDD	GND	Y3	$\overline{Y4}$
1	Y0	$\overline{Y1}$	GND	Y2	VDDQ	CLK	VDDQ	AGND	$\overline{Y3}$	Y4
	A	B	C	D	E	F	G	H	J	K

VFBGA
TOP VIEW

56 BALL VFBGA PACKAGE LAYOUT

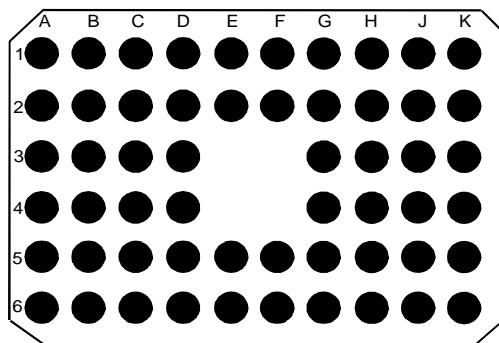
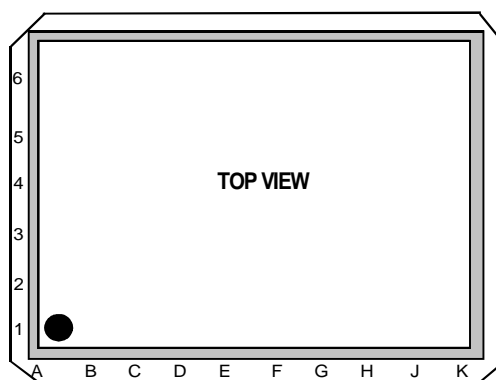
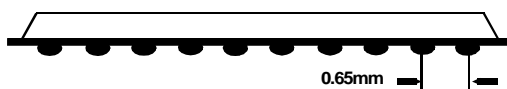

RECOMMENDED OPERATING CONDITIONS

Symbol	Parameter	Min.	Typ.	Max.	Unit	
AV _{DD}	Supply Voltage	V _{DDO} -0.12	V _{DDO}	2.7	V	
V _{DDO}	I/O Supply Voltage	PC1600-PC2700	2.3	2.5	2.7	V
		PC3200	2.5	2.6	2.7	
T _A	Operating Free-Air Temperature	-40	—	+85	°C	

PIN DESCRIPTION (TSSOP/TVSOP)

Pin Name	Pin Number	Description
AGND	17	Ground for analog supply
AV _{DD}	16	Analog supply
CLK, $\overline{\text{CLK}}$	13, 14	Differential clock input
$\overline{\text{FBIN}}$, FBIN	35, 36	Feedback differential clock input
FBO _{UT} , $\overline{\text{FBOU}}\overline{\text{T}}$	32, 33	Feedback differential clock output
GND	1, 7, 8, 18, 24, 25, 31, 41, 42, 48	Ground
$\overline{\text{PWRDWN}}$	37	Output enable for Y and $\overline{\text{Y}}$
V _{DDO}	4, 11, 12, 15, 21, 28, 34, 38, 45	I/O supply
Y _[0:9]	3, 5, 10, 20, 22, 27, 29, 39, 44, 46	Buffered output of input clock, CLK
$\overline{\text{Y}}_{[0:9]}$	2, 6, 9, 19, 23, 26, 30, 40, 43, 47	Buffered output of input clock, $\overline{\text{CLK}}$

PIN DESCRIPTION (VFBGA)

Pin Name	Pin Number	Description
AGND	H1	Ground for analog supply
AV _{DD}	G2	Analog supply
CLK, $\overline{\text{CLK}}$	F1, F2	Differential clock input
$\overline{\text{FBIN}}$, FBIN	F5, F6	Feedback differential clock input
FBO _{UT} , $\overline{\text{FBOU}}\overline{\text{T}}$	H6, G5	Feedback differential clock output
GND	A3, A4, C1, C2, C5, C6, H2, H5, K3, K4	Ground
$\overline{\text{PWRDWN}}$	E6	Output enable for Y and $\overline{\text{Y}}$
V _{DDO}	B3, B4, E1, E2, E5, G1, G6, J3, J4	I/O supply
Y _[0:9]	A1, A6, B2, B5, D1, D6, J2, J5, K1, K6	Buffered output of input clock, CLK
$\overline{\text{Y}}_{[0:9]}$	A2, A5, B1, B6, D2, D5, J1, J6, K2, K5	Buffered output of input clock, $\overline{\text{CLK}}$

PIN DESCRIPTION (MLF)

Pin Name	Pin Number	Description
AGND	9	Ground for analog supply
AV _{DD}	8	Analog supply
CLK, $\overline{\text{CLK}}$	5, 6	Differential clock input
$\overline{\text{FBIN}}$, FBIN	25, 26	Feedback differential clock input
FBO _{UT} , $\overline{\text{FBOU}}\overline{\text{T}}$	21, 22	Feedback differential clock output
GND	1, 10	Ground
$\overline{\text{PWRDWN}}$	27	Output enable for Y and $\overline{\text{Y}}$
V _{DDO}	4, 7, 13, 18, 23, 24, 28, 33, 38	I/O supply
Y _[0:9]	3, 12, 14, 17, 19, 29, 32, 34, 37, 39	Buffered output of input clock, CLK
$\overline{\text{Y}}_{[0:9]}$	2, 11, 15, 16, 20, 30, 31, 35, 36, 40	Buffered output of input clock, $\overline{\text{CLK}}$

FUNCTION TABLE⁽¹⁾

INPUTS				OUTPUTS				
AVDD	PWRDWN	CLK	CLK	Y	Y	FBOUT	FBOUT	PLL
GND	H	L	H	L	H	L	H	Bypassed/OFF
GND	H	H	L	H	L	H	L	Bypassed/OFF
X	L	L	H	Z	Z	Z	Z	OFF
X	L	H	L	Z	Z	Z	Z	OFF
Nominal ⁽²⁾	H	L	H	L	H	L	H	ON
Nominal ⁽²⁾	H	H	L	H	L	H	L	ON
Nominal ^(2,3)	X	<20MHz	<20MHz	Z	Z	Z	Z	OFF

NOTES:

- H = HIGH Voltage Level
L = LOW Voltage Level
Z = High-Impedance OFF-State
X = Don't Care
- AVDD nominal is 2.5V for PC1600, PC2100, and PC2700. AVDD nominal is 2.6V for PC3200.
- Additional feature that senses when the clock input is less than approximately 20MHz and places the part in sleep mode. Receiver inputs and PLL are turned off and outputs = tristate.

DC ELECTRICAL CHARACTERISTICS OVER OPERATING RANGE FOR PC1600 - PC2700

Following Conditions Apply Unless Otherwise Specified:

Commercial: TA = 0°C to +70°C; Industrial: TA = -40°C to +85°C

Symbol	Parameter	Conditions	Min.	Typ.	Max.	Unit
V _{IK}	Input Clamp Voltage (All Inputs)	V _{DDQ} = 2.3V, I _I = -18mA	—	—	-1.2	V
V _{IL(dc)}	Static Input LOW Voltage	PWRDWN	-0.3	—	0.7	V
V _{IH(dc)}	Static Input HIGH Voltage	PWRDWN	1.7	—	V _{DDQ} + 0.3	V
V _{IL(ac)}	Dynamic Input LOW Voltage	CLK, CLK, FBIN, FBIN	—	—	0.7	V
V _{IH(ac)}	Dynamic Input HIGH Voltage	CLK, CLK, FBIN, FBIN	1.7	—	V _{DDQ}	V
V _{OL}	Output LOW Voltage	AVDD/VDDQ = Min., I _{OL} = 100μA	—	—	0.1	V
		AVDD/VDDQ = Min., I _{OL} = 12mA	—	—	0.6	V
V _{OH}	Output HIGH Voltage	AVDD/VDDQ = Min., I _{OH} = -100μA	V _{DDQ} - 0.1	—	—	V
		AVDD/VDDQ = Min., I _{OH} = -12mA	1.7	—	—	V
V _{IX}	Input Differential Cross Voltage		V _{DDQ} /2 - 0.2	—	V _{DDQ} /2 + 0.2	V
V _{ID(DC)} ⁽¹⁾	DC Input Differential Voltage		0.36	—	V _{DDQ} + 0.6	V
V _{ID(AC)} ⁽¹⁾	AC Input Differential Voltage		0.7	—	V _{DDQ} + 0.6	V
I _{IN}	Input Current	V _{DDQ} = 2.7V, V _I = 0V to 2.7V	—	—	±10	μA
I _{DDP}	Power-Down Current on VDDQ and AVDD	AVDD/VDDQ = Max., CLK = 0MHz or PWRDWN = L	—	100	200	μA
I _{DDQ}	Dynamic Power Supply Current on VDDQ	AVDD/VDDQ = Max., CLK = 200MHz, 120Ω/14pF	—	320	360	mA
		AVDD/VDDQ = Max., CLK = 170MHz, 120Ω/14pF	—	250	300	mA
I _{ADD}	Dynamic Power Supply Current on AVDD	AVDD/VDDQ = Max., CLK = 170MHz	—	—	12	mA

NOTE:

- V_{ID} is the magnitude of the difference between the input level on CLK and the input level on CLK.

DC ELECTRICAL CHARACTERISTICS OVER OPERATING RANGE FOR PC3200

Following Conditions Apply Unless Otherwise Specified:

Commercial: TA = 0°C to +70°C; Industrial: TA = -40°C to +85°C

Symbol	Parameter	Conditions	Min.	Typ.	Max.	Unit
V _{IK}	Input Clamp Voltage (All Inputs)	V _{DDQ} = 2.5V, I _I = -18mA	—	—	-1.2	V
V _{IL(dc)}	Static Input LOW Voltage	$\overline{\text{PWRDWN}}$	-0.3	—	0.7	V
V _{IH(dc)}	Static Input HIGH Voltage	$\overline{\text{PWRDWN}}$	1.7	—	V _{DDQ} + 0.3	
V _{IL(ac)}	Dynamic Input LOW Voltage	CLK, $\overline{\text{CLK}}$, FBIN, $\overline{\text{FBIN}}$	—	—	0.7	V
V _{IH(ac)}	Dynamic Input HIGH Voltage	CLK, $\overline{\text{CLK}}$, FBIN, $\overline{\text{FBIN}}$	1.7	—	V _{DDQ}	
V _{OL}	Output LOW Voltage	Av _{DD} /V _{DDQ} = Min., I _{OL} = 100μA	—	—	0.1	V
		Av _{DD} /V _{DDQ} = Min., I _{OL} = 12mA	—	—	0.6	
V _{OH}	Output HIGH Voltage	Av _{DD} /V _{DDQ} = Min., I _{OH} = -100μA	V _{DDQ} - 0.1	—	—	V
		Av _{DD} /V _{DDQ} = Min., I _{OH} = -12mA	1.7	—	—	
V _{IX}	Input Differential Cross Voltage		V _{DDQ} /2 - 0.2	—	V _{DDQ} /2 + 0.2	V
V _{ID(DC)} ⁽¹⁾	DC Input Differential Voltage		0.36	—	V _{DDQ} + 0.6	V
V _{ID(AC)} ⁽¹⁾	AC Input Differential Voltage		0.7	—	V _{DDQ} + 0.6	V
I _{IN}	Input Current	V _{DDQ} = 2.7V, V _I = 0V to 2.7V	—	—	±10	μA
I _{DDP}	Power-Down Current on V _{DDQ} and Av _{DD}	Av _{DD} /V _{DDQ} = Max., CLK = 0MHz or $\overline{\text{PWRDWN}} = \text{L}$	—	100	200	μA
I _{DDQ}	Dynamic Power Supply Current on V _{DDQ}	Av _{DD} /V _{DDQ} = Max., CLK = 200MHz, 120Ω/14pF	—	320	360	mA
		Av _{DD} /V _{DDQ} = Max., CLK = 200MHz, 120Ω/14pF	—	250	300	
I _{ADD}	Dynamic Power Supply Current on Av _{DD}	Av _{DD} /V _{DDQ} = Max., CLK = 200MHz	—	—	12	mA

NOTE:

1. V_{ID} is the magnitude of the difference between the input level on CLK and the input level on $\overline{\text{CLK}}$.

TIMING REQUIREMENTS FOR PC1600 - PC2700

Symbol	Parameter	Min.	Max.	Unit
f _{CLK}	Operating Clock Frequency ^(1,2)	60	200	MHz
	Application Clock Frequency ^(1,3)	60	200	MHz
t _{DC}	Input Clock Duty Cycle	40	60	%
t _L	Stabilization Time ⁽⁴⁾	—	100	μs

NOTES:

- The PLL will track a spread spectrum clock input.
- Operating clock frequency is the range over which the PLL will lock, but may not meet all timing specifications.
- Application clock frequency is the range over which timing specifications apply.
- Stabilization time is the time required for the integrated PLL circuit to obtain phase lock of its feedback signal to its reference signal after power up.

TIMING REQUIREMENTS FOR PC3200

Symbol	Parameter	Min.	Max.	Unit
f _{CLK}	Operating Clock Frequency ^(1,2)	60	220	MHz
	Application Clock Frequency ^(1,3)	60	220	MHz
t _{DC}	Input Clock Duty Cycle	40	60	%
t _L	Stabilization Time ⁽⁴⁾	—	100	μs

NOTES:

- The PLL will track a spread spectrum clock input.
- Operating clock frequency is the range over which the PLL will lock, but may not meet all timing specifications.
- Application clock frequency is the range over which timing specifications apply.
- Stabilization time is the time required for the integrated PLL circuit to obtain phase lock of its feedback signal to its reference signal after power up.

SWITCHING CHARACTERISTICS FOR PC1600 - PC2700

Symbol	Description	Test Conditions	Min.	Typ. ⁽¹⁾	Max.	Unit
t _{PLH} ⁽¹⁾	LOW to HIGH Level Propagation Delay Time	Test mode, CLK to any output		4.5		ns
t _{PHL} ⁽¹⁾	HIGH to LOW Level Propagation Delay Time	Test mode, CLK to any output		4.5		ns
t _{JIT(PER)}	Jitter (period), see figure 6	66MHz	-90		90	ps
		100/ 133/ 167/ 200 MHz	-75		75	
t _{JIT(CC)}	Jitter (cycle-to-cycle), see figure 3	66MHz	-180		180	ps
		100/ 133/ 167/ 200 MHz	-75		75	
t _{JIT(HPER)}	Half-Period Jitter, see figure 7	66MHz	-160		160	ps
		100/ 133/ 167/ 200 MHz	-100		100	
t _{SLR(O)}	Output Clock Slew Rate (Single-Ended)	100/ 133/ 167/ 200 MHz (20% to 80%)	1		2.5	V/ns
t _{SLR(I)}	Input Clock Slew Rate		1		4	V/ns
t(∅)	Static Phase Offset, see figure 4 ^(2,3)	66/ 100/ 133/ 167/ 200 MHz	-50		50	ps
t _{SK(O)}	Output Skew, see figure 5				75	ps
t _{R, F}	Output Rise and Fall Times (20% to 80%)	Load: 120Ω / 14pF	650		900	ps
V _{OX} ⁽⁵⁾	Output Differential Voltage	Differential outputs are terminated with 120Ω	V _{DDO} /2 -0.15		V _{DDO} /2 +0.15	V
The PLL on the CSPT857 will meet all the above test parameters while supporting SSC synthesizers ⁽⁴⁾ with the following parameters:						
SSC	Modulation Frequency	—	30	—	50	KHz
SSC	Clock Input Frequency Deviation	—	0	—	-0.5	%
f _{3dB}	PLL Loop Bandwidth	—	—	5	—	MHz

NOTES:

1. Refers to transition of non-inverting output.
2. Static phase offset does not include jitter.
3. t(∅) is measured with input clock slew rate t_{SLR(I)} = 2V/ns and an input differential voltage V_{ID} of 1.75V.
4. The SSC requirements meet the Intel PC100 SDRAM Registered DIMM specification.
5. V_{OX} is specified at the SDRAM clock input or test load.

SWITCHING CHARACTERISTICS FOR PC3200

Symbol	Description	Test Conditions	Min.	Typ. ⁽¹⁾	Max.	Unit
t _{PLH} ⁽¹⁾	LOW to HIGH Level Propagation Delay Time	Test mode, CLK to any output		4.5		ns
t _{PHL} ⁽¹⁾	HIGH to LOW Level Propagation Delay Time	Test mode, CLK to any output		4.5		ns
t _{JIT(PER)}	Jitter (period), see figure 6	66MHz	-90		90	ps
		200 MHz	-50		50	
t _{JIT(CC)}	Jitter (cycle-to-cycle), see figure 3	66MHz	-180		180	ps
		200 MHz	-75		75	
t _{JIT(HPER)}	Half-Period Jitter, see figure 7	66MHz	-160		160	ps
		200 MHz	-75		75	
t _{SLR(O)}	Output Clock Slew Rate (Single-Ended)	200 MHz (20% to 80%)	1		2.5	V/ns
t _{SLR(I)}	Input Clock Slew Rate		1		4	V/ns
t(∅)	Static Phase Offset, see figure 4 ^(2,3)	200 MHz	-50		50	ps
t _{SK(O)}	Output Skew, see figure 5				75	ps
t _{R,TF}	Output Rise and Fall Times (20% to 80%)	Load: 120Ω / 14pF	650		900	ps
V _{OX} ⁽⁵⁾	Output Differential Voltage	Differential outputs are terminated with 120Ω	V _{DDO} /2 -0.15		V _{DDO} /2 +0.15	V
The PLL on the CSPT857 will meet all the above test parameters while supporting SSC synthesizers ⁽⁴⁾ with the following parameters:						
SSC	Modulation Frequency	—	30	—	50	KHz
SSC	Clock Input Frequency Deviation	—	0	—	-0.5	%
f _{3dB}	PLL Loop Bandwidth	—	—	5	—	MHz

NOTES:

1. Refers to transition of non-inverting output.
2. Static phase offset does not include jitter.
3. t(∅) is measured with input clock slew rate t_{SLR(I)} = 2V/ns and an input differential voltage V_{ID} of 1.75V.
4. The SSC requirements meet the Intel PC100 SDRAM Registered DIMM specification.
5. V_{OX} is specified at the SDRAM clock input or test load.

TEST CIRCUIT AND SWITCHING WAVEFORMS

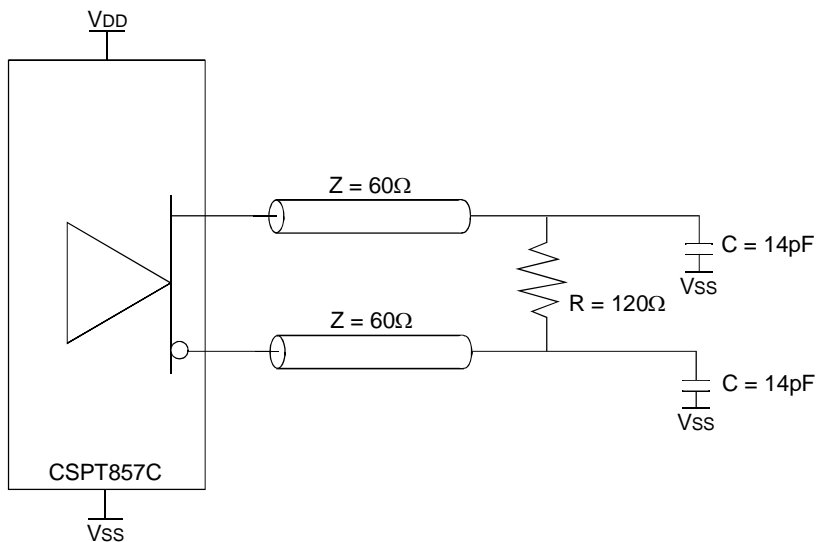

Figure 1. Output Load

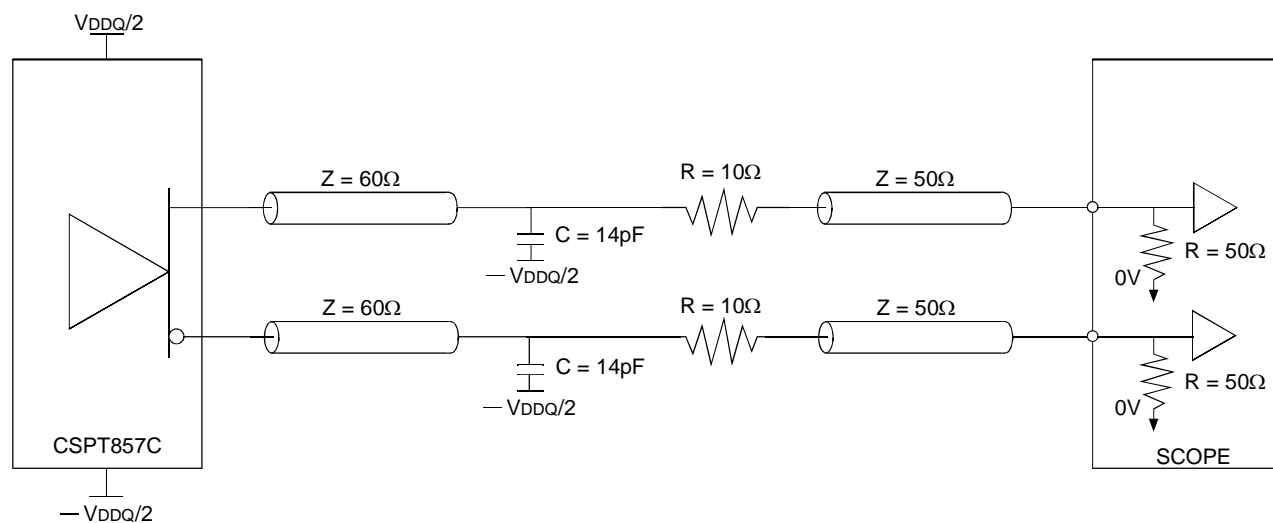
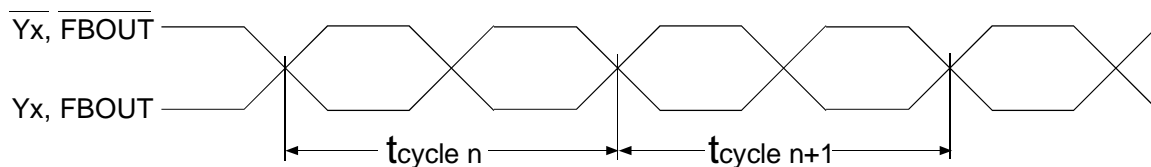

Figure 2. Output Load Test Circuit

TEST CIRCUIT AND SWITCHING WAVEFORMS



$$t_{jit(cc)} = t_{cycle\ n} - t_{cycle\ n+1}$$

Figure 3. Cycle-to-Cycle jitter

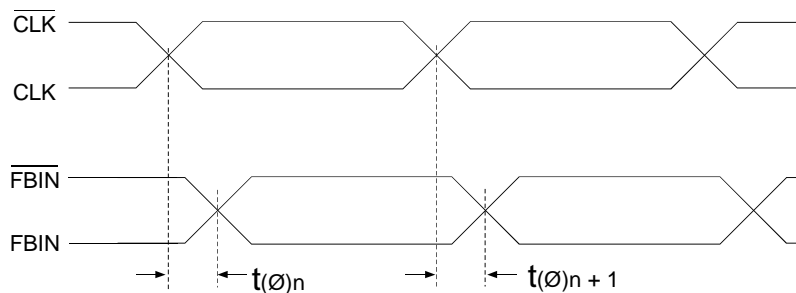

$$t(\emptyset) = \frac{\sum_{n=1}^{n=N} t(\emptyset)_n}{N} \quad (N \text{ is a large number of samples})$$

Figure 4. Static Phase Offset

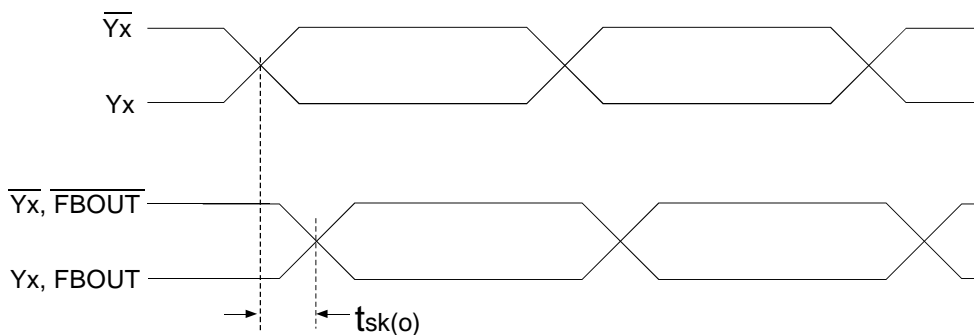
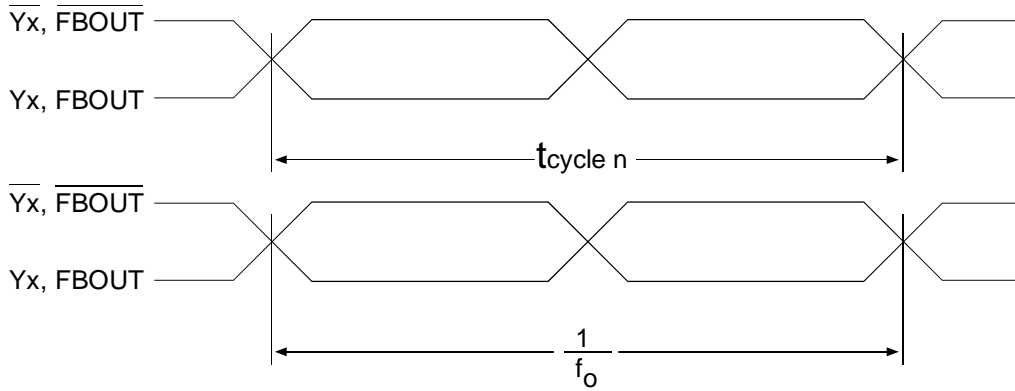

Figure 5. Output Skew

TEST CIRCUIT AND SWITCHING WAVEFORMS



$$t_{\text{jit(per)}} = t_{\text{cycle } n} - \frac{1}{f_0}$$

Figure 6. Period jitter

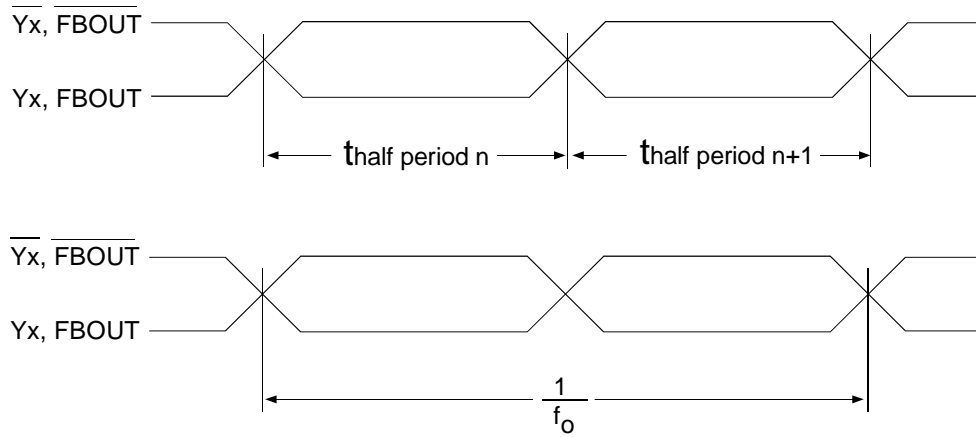

$$t_{\text{jit(hper)}} = t_{\text{half period } n} - \frac{1}{2 \cdot f_0}$$

Figure 7. Half-Period jitter

TEST CIRCUIT AND SWITCHING WAVEFORMS



Figure 8. Input and Output Slew Rates

APPLICATION INFORMATION

Clock Structure	# of SDRAM Loads per Clock	Clock Loading on the PLL outputs (pF)	
		Min.	Max.
#1	2	4	7
#2	4	8	14

APPLICATION INFORMATION

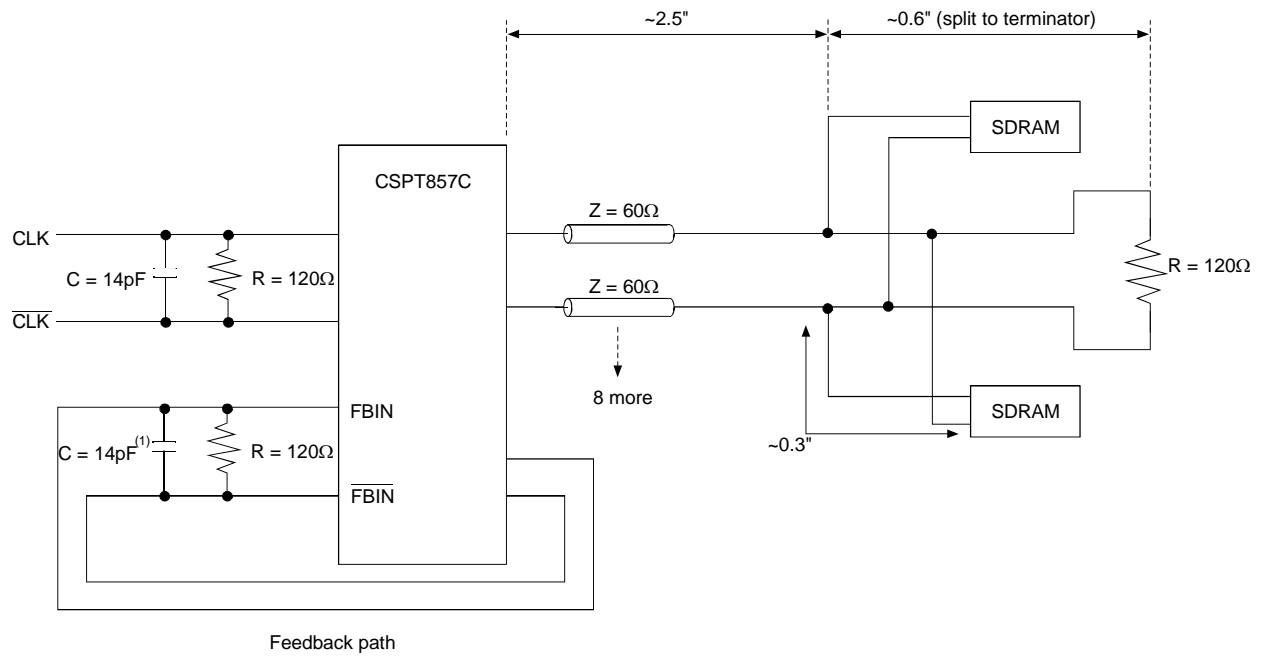

Figure 9. Clock Structure 1

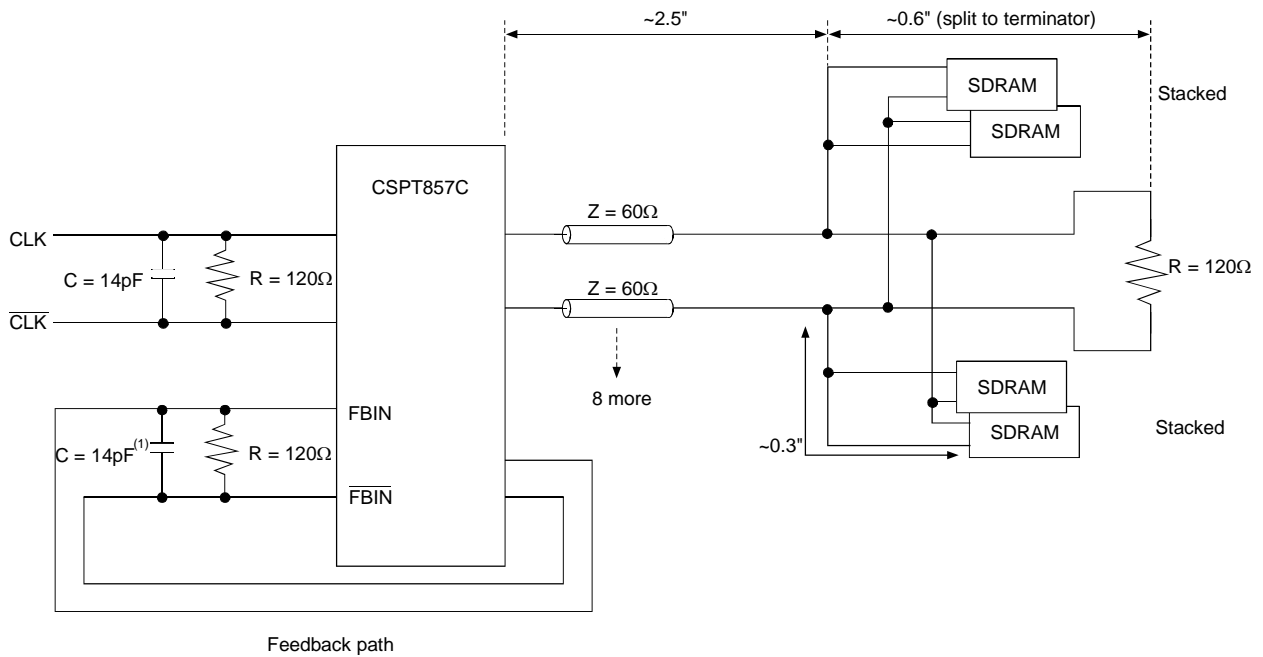

Figure 10. Clock Structure 2

NOTE:

1. Memory module vendors may need to adjust the feedback capacitive load in order to meet DDR SDRAM registered DIMM timing requirements.

ORDERING INFORMATION

IDTCSPT	XXXXX	XX	X		
	Device Type	Package	Process		
			I	Blank	0°C to +70°C (Commercial) -40°C to +85°C (Industrial)
			PA	Thin Shrink Small Outline Package	
			PAG	TSSOP - Green	
			PF	Thin Very Small Outline Package	
			BV	Very Fine Pitch Ball Grid Array	
			NL	Thermally-Enhanced Plastic Very Fine Pitch	
			NLG	Flat No Lead Package	
				MLF - Green	
			857C	2.5V - 2.6V PLL Differential 1:10 SDRAM Clock Driver	



CORPORATE HEADQUARTERS
2975 Stender Way
Santa Clara, CA 95054

for SALES:
800-345-7015 or 408-727-6116
fax: 408-492-8674
www.idt.com

for Tech Support:
logichelp@idt.com
(408) 654-6459



LittleDiode supplies new, hard to find or obsolete electronic components and semiconductors all over the world.

With over two million different components listed you are sure to find the part you need.

Feel free to visit us today at our online store:

LittleDiode.com

Looking forward to providing you with the best possible service.