

FEATURES

- Bandwidth 65MHz
- Rise/Fall Time..... <6.0ns
- Swing 50 V_{P-P}
- Supply Voltage..... 80V
- Pin to Pin Compatible with CVA2416 and LM2416

APPLICATIONS

- CRT Driver for VGA and SVGA Color Monitors

DESCRIPTION

The CVA2415 contains three wide bandwidth, large signal amplifiers designed specially to drive VGA and SVGA color monitors. The device is a low cost CRT driver designed especially to replace discrete solutions.

The part is housed in the industry standard 11-lead TO-220 molded power package. The heat sink is floating and may be grounded for ease of manufacturing and RFI shielding.

ORDERING INFORMATION

Part	Package	Temperature
CVA2415T	T11A	-20°C to +100°C

CONNECTION DIAGRAM

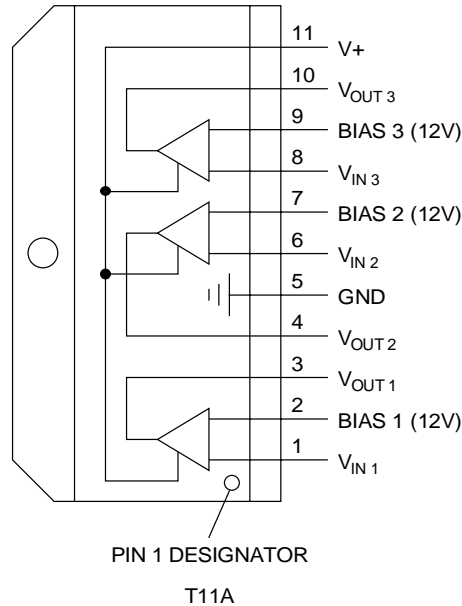

ABSOLUTE MAXIMUM RATINGS

Supply Voltage 85V Operating Temperature -20°C to +100°C
 Storage Temperature -25°C to +100°C Lead Temperature +300°C

DC ELECTRICAL CHARACTERISTICS $V_S = 80V, C_L = 12pF, V_{bias} = 12V, V_{in} = 3.6V, T_{case} = +25^\circ C$. See Figure 1.

SYMBOL	CHARACTERISTICS	MIN	TYP	MAX	UNITS
I _{cc}	Supply Current @ 1MHz	18	22	26	mA
I _{cc}	Supply Current @ 50MHz		40		mA
V _{outDC}	Output DC Level	38	42	46	V
A _v	Voltage Gain	11	13	15	V
	Gain Matching		0.2		dB

AC ELECTRICAL CHARACTERISTICS $V_S = 80V, C_L = 12pF, V_{bias} = 12V, T_{case} = +25^\circ C$. See Figure 1.

SYMBOL	CHARACTERISTICS	MIN	TYP	MAX	UNITS
t _r	Rise Time		5.6	7.0	ns
t _f	Fall Time		4.5	6.0	ns
BW	Bandwidth		65		MHz
Le	Linearity		8		%
OS	Overshoot		0		%

FIGURE 1. APPLICATION AND TEST CIRCUIT

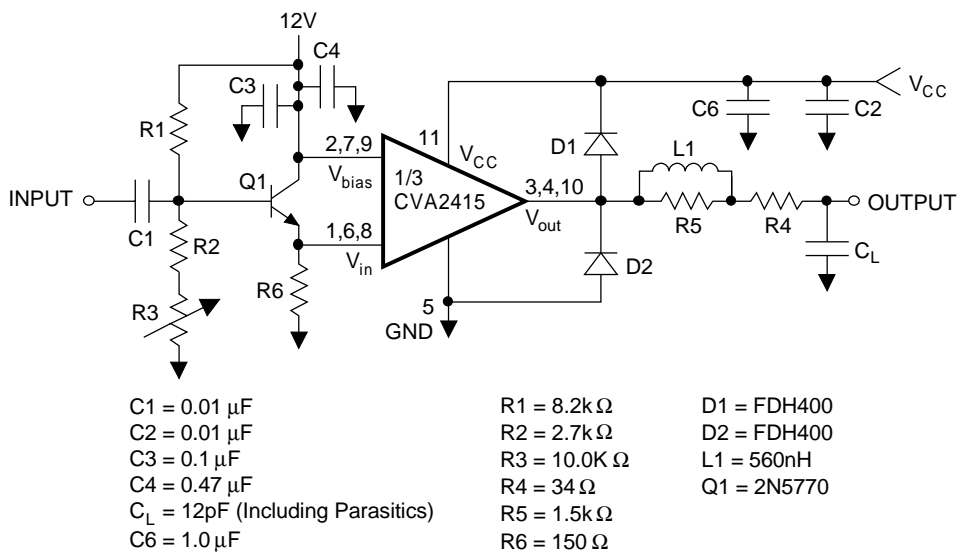

APPLICATION INFORMATION

The CVA2415 is a high voltage triple CRT driver suitable for VGA, Super VGA, IBM® 8514 1024 x 768 non-interlaced display applications. The CVA2415 features 80V operation and low power dissipation. The part is housed in the industry standard 11 lead TO-220 molded power package. The heat sink is floating and may be grounded for ease of manufacturing and RFI shielding.

Thermal Considerations

The transfer characteristics of the amplifier are shown in *Figure 2*. Since this is a class A input stage, power supply current increases as the input signal increases and consequently power dissipation also increases. Average power dissipation per stage is 1.8W, increasing to 3.2W at minimum output voltage.

The CVA2415 cannot be used without heat sinking. *Figure 2* shows the power dissipated in each channel over the operating voltage range of the device, Typical "average" power dissipation with the device output voltage at one half the supply voltage is 1.8W per channel for a total dissipation of 5.4W package dissipation. Under white screen conditions, i.e.: 15V output, dissipation increases to 3W per channel or 9W total. The CVA2415 case temperature must be maintained below +100°C. If the maximum expected ambient temperature is +50°C, then a heat sink is needed with thermal resistance equal to or less than:

$$R_{th} = \frac{(100 - 50^{\circ}C)}{9W} = 5.5^{\circ}C/W$$

FIGURE 2. CVA2415 DC Characteristics

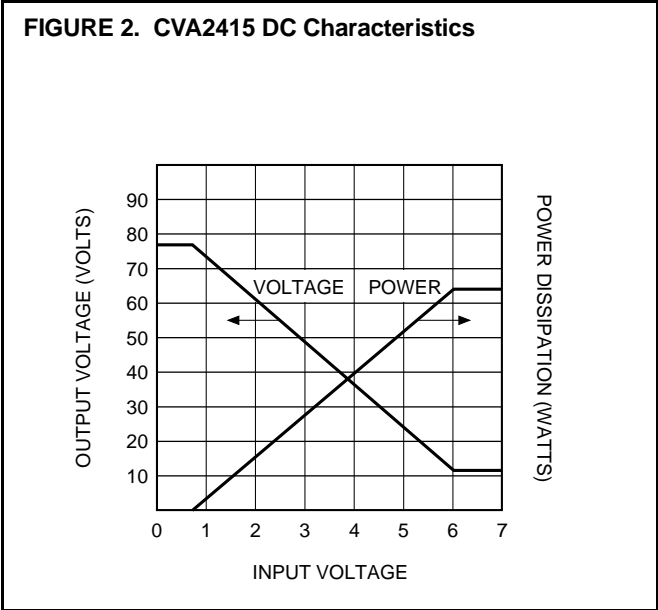

The Thermalloy #6400 is one example of a heatsink that meets this requirement.

The output of CVA2415 is not short circuit proof. Any resistance to V⁺ or Ground should be > 600Ω.

FIGURE 3.

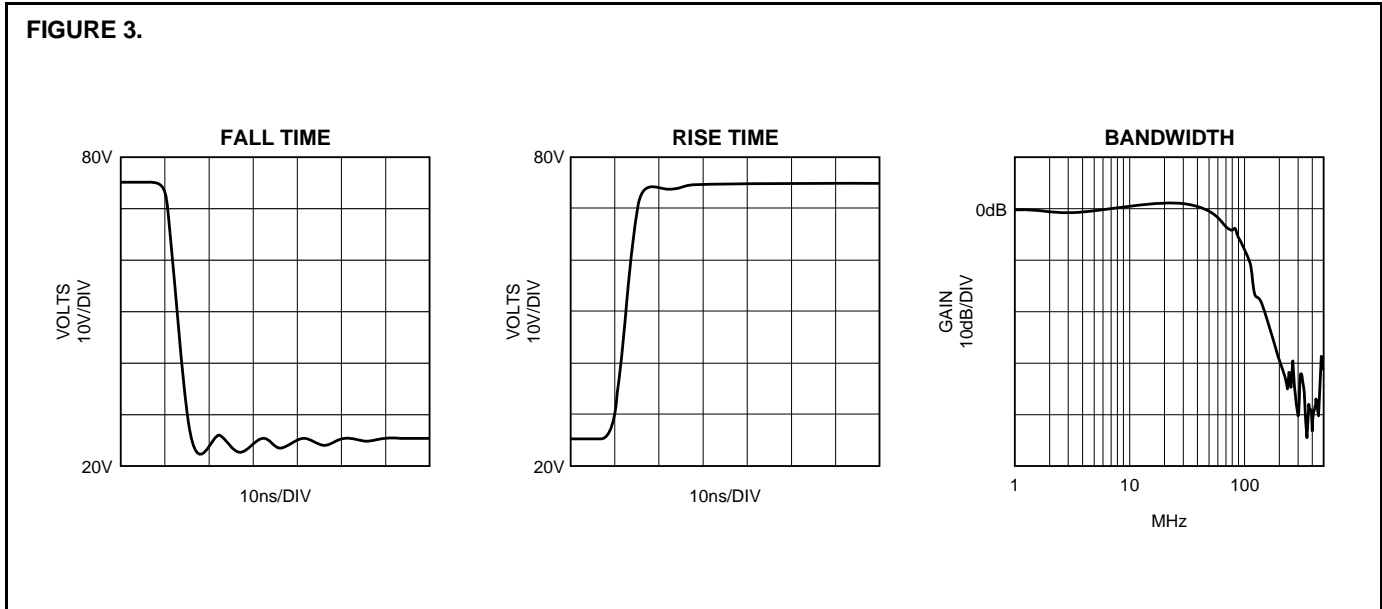

TYPICAL APPLICATION

A typical application of the CVA2415 is shown in *Figure 4*. Used in conjunction with a CVA1203, a complete video channel from monitor input to CRT cathode is shown. In this application, feedback is local to the CVA1203. An alternative

scheme would be feedback from the output of the CVA2415 to the positive clamp inputs of the CVA1203. This would provide slightly better black level control of the system.

FIGURE 4. Typical Application CVA1203 - CVA2415 Application

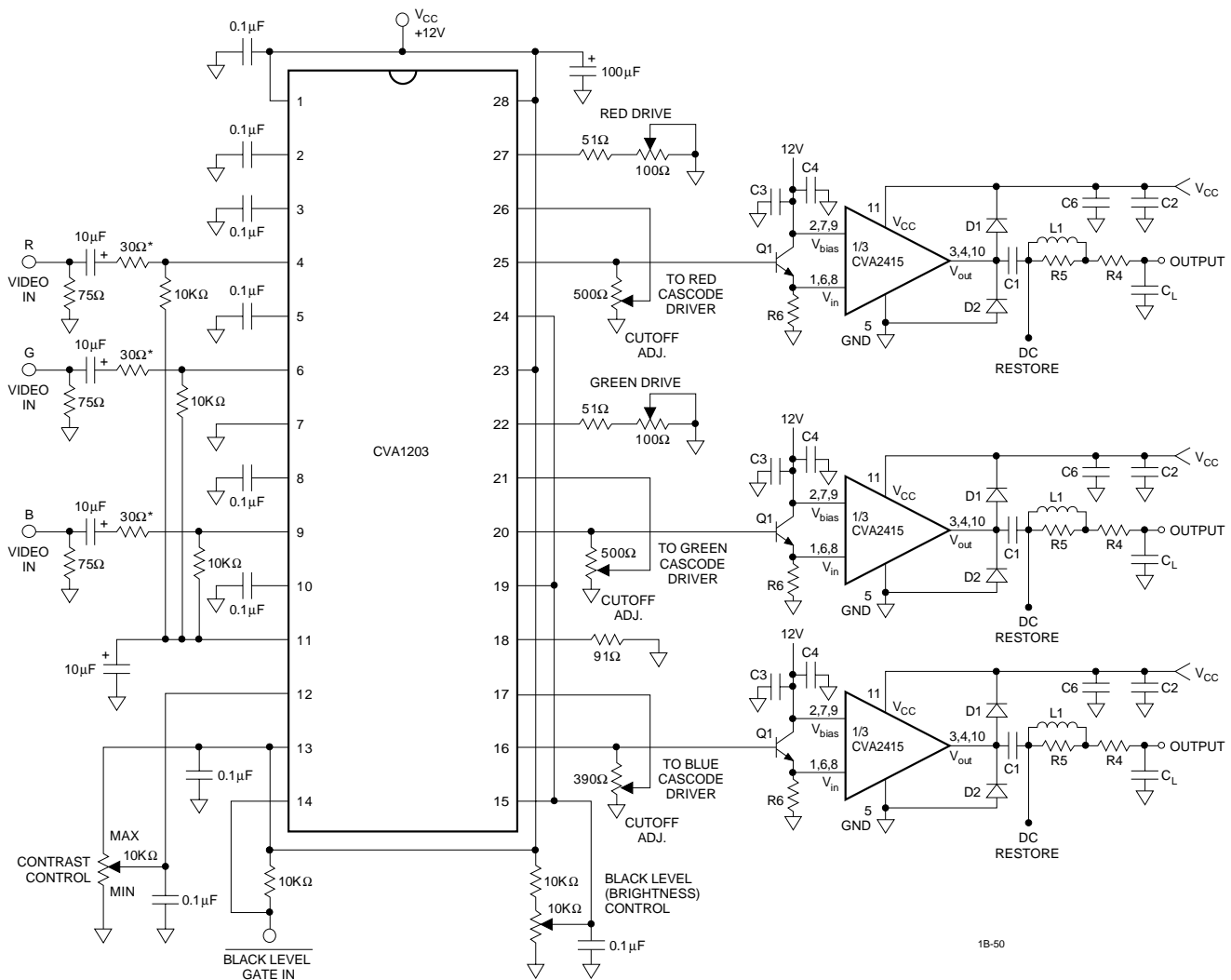

	C1 μF	C2 μF	C3 μF	C4 μF	CL* pF	C6 μF	R4 Ω	R5 KΩ	R6 Ω	D1	D2	L1 nH	Q1
CVA2415	1.0	0.01	0.1	0.47	12	1.0	34	1.5	150	FDH400	FDH400	560	2N5770

This datasheet has been downloaded from:

www.DatasheetCatalog.com

Datasheets for electronic components.



LittleDiode supplies new, hard to find or obsolete electronic components and semiconductors all over the world.

With over two million different components listed you are sure to find the part you need.

Feel free to visit us today at our online store:

LittleDiode.com

Looking forward to providing you with the best possible service.