

FEATURES

- Rise/Fall Time..... 3ns
- Swing 70V_{P-P}
- Symmetrical Rise and Fall Time
- Excellent Gray Scale Linearity

APPLICATION

- CRT Driver for up to 90khz Monitors with Resolution upto 1600 x 1280 (Non-Interlaced).

DESCRIPTION

The CVA6627S contains three wideband amplifiers designed specifically to drive high resolution CRTs. It features excellent gray scale linearity and high load capacitance driving capability. This device can drive monitors with resolution of 1600 x 1280 (non-interlaced) with pixel frequency of 300MHz.

The part is housed in 12L Ceramic package with heat sink grounded.

ORDERING INFORMATION

Part	Package	Temperature
CVA6627S	CY12B	-20°C to +100°C

CONNECTION DIAGRAM AND SIMPLIFIED SCHEMATIC

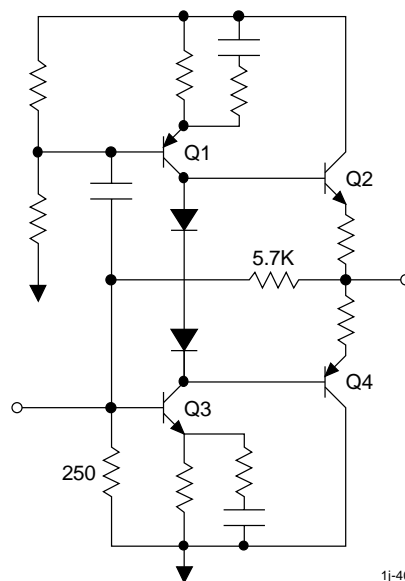
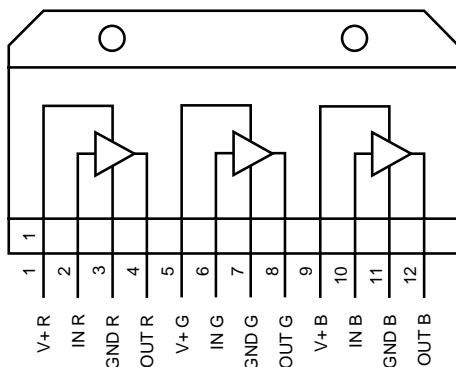

1j-40

ABSOLUTE MAXIMUM RATINGS

Supply Voltage 85V Operating Temperature -20°C to +100°C
 Storage Temperature -25°C to +125°C Lead Temperature +300°C

DC ELECTRICAL CHARACTERISTICS $V_S = 80V$, $C_L = 10pF$, $V_{OUT} = 50VP-P$, $T_{CASE} = +25°C$. See Figure 1.

SYMBOL	CHARACTERISTICS	MIN	TYP	MAX	UNITS
I_{CC}	Supply Current		26	32	mA
V_{INDC}	Input DC Level	1.4	1.6	1.8	V
V_{OUTDC}	Output DC Level	34	38	42	V
A_V	Voltage Gain	11	13	15	V
	Gain Matching		0.2		dB

AC ELECTRICAL CHARACTERISTICS $V_S = 80V$, $C_L = 10pF$, $V_{OUT} = 50VP-P$, $T_{CASE} = +25°C$. See Figure 1.

SYMBOL	CHARACTERISTICS	MIN	TYP	MAX	UNITS
t_r	Rise Time		3.1	4.0	ns
t_f	Fall Time		3.1	4.0	ns
BW	Bandwidth		140		MHz
Le	Linearity		5		%
OS	Overshoot		4		%

FIGURE 1. TEST CIRCUIT

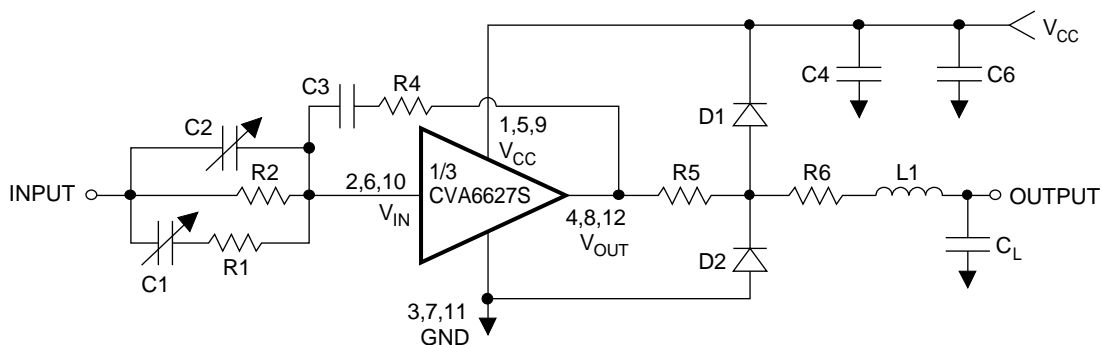

- R1 = 15 Ω R4 = 200k C1 = VARIABLE 20 TO 150pF C4 = 10 μf/160V D1 = DS464
- R2 = 430 Ω R5 = 22 Ω C2 = VARIABLE 4 TO 20pF C6 = 0.01 μf/160V D2 = DS464
- R6 = 22 Ω C3 = 75pF C_L = 10pF L1 = 150nH

APPLICATION INFORMATION

The CVA6627S is a transimpedance amplifier with two stage feedback configurations. Any change in input current will be reflected as change in output voltage swing. A resistor in series with the input will change the CVA6627S into a voltage amplifier. The output is emitter follower with load(capacitive) driven capability.

With a true Class AB output stage, the rise and fall time is symmetric.

CVA6627S has an internal feedback resistor of 5.7K Ω . In the absence of any input signal, the V_{OUT} DC is set by

$$V_{OUT}(DC) = (1 + \frac{R_F}{R_B}) V_{IN}(DC); R_B = 250\Omega.$$

An input resistor R_G will set the gain as

$$V_{OUT} = (\frac{R_F}{R_G}) V_{IN}; R_G = \text{gain resistor.}$$

Input and Transfer Characteristics

An input current swing of $\pm 4.4\text{mA}$ causes the output to change by $\pm 25\text{V}$. A resistor of 430 Ω will set the gain to -13. Input pins are internal DC feedback nodes and thus have low impedance. These pins must be fed from a series RC network for high frequency emphasis.

The following section will explain how to overcome some of the problems that are typical.

1) Input drive: CVA6627S gives best results when the amplifier is driven by a fast pulse with proper voltage level. Since all pre-amplifiers have output from 0 to 8V, a level shifter is required. Also, most pre-amplifiers cannot drive a large capacitive load.

2) Smear: For a box pattern with white background, a shadow after the black is called smear. It is due to the tilt of the white level. It can easily be adjusted by adding an RC feedback network (R_4 , C_3). The value of R_4 will affect the gain, for CVA6627S, the typical value is 200K.

3) Streaks and overshoot: For a cross-hatch pattern with white background, a whitish line will appear just after the black line, this is called streak. Looking at the waveform it is due to undershoot of the waveform. For a Box pattern with white background, a dark black area just after white is a sign of overshoot. It is due to overshoot of the waveform. Adjusting the value of C_2 , R_1 , C_1 will get the optimum result. The value of C_2 should be kept at minimum for less overshoot, typical is <20pF. Value of R_1 should be less than 47 ohms otherwise rise and fall time will suffer. First adjust the overshoot to minimum, keeping value of C_1 and R_2 to minimum, then adjust the undershoot (Streak) by adjusting C_3 again. Since both need to be adjusted together, this may need a few iteration to get to the optimum result.

It should be noted here that the output peaking with L_1 and R_3 is only to overcome the affect of stray capacitance. Keep the value of L_1 to minimum, typ 150nH and R , to be 820 Ω . The value of L_1 depends on the associated capacitance with the board and the cable(if any). CVA6627S is specifically designed to handle extra capacitance associated with the cable(typ. 10pF) assuming the driver is not part of the neck board. The value of R_3 should be less than 1K to damped the resonant ringing.

The output of CVA6627S is not short circuit proof. Precaution is required.

Thermal Characteristics

Under normal operating conditions the CVA6627S will dissipate up to 11W. The maximum allowed case temperature is +100 $^{\circ}\text{C}$. To calculate maximum heatsink thermal resistance use the following equation:

$$R_{th} = \frac{(100 - 50^{\circ})}{11\text{W}} = 4.5^{\circ}\text{C/W}$$

The Thermalloy #11699 is one example of a heatsink that meets this requirement.



LittleDiode supplies new, hard to find or obsolete electronic components and semiconductors all over the world.

With over two million different components listed you are sure to find the part you need.

Feel free to visit us today at our online store:

LittleDiode.com

Looking forward to providing you with the best possible service.