

CX-16F

SMD

■Features

- Compact, thickness 1.6mm or less.
- Leadless, ceramic package.
- Automatic mounting.
- Emboss tapping specification.
- Re-flow soldering.
- Low cost.
- The oscillation circuit can obtain sufficient output at the inverter stage.

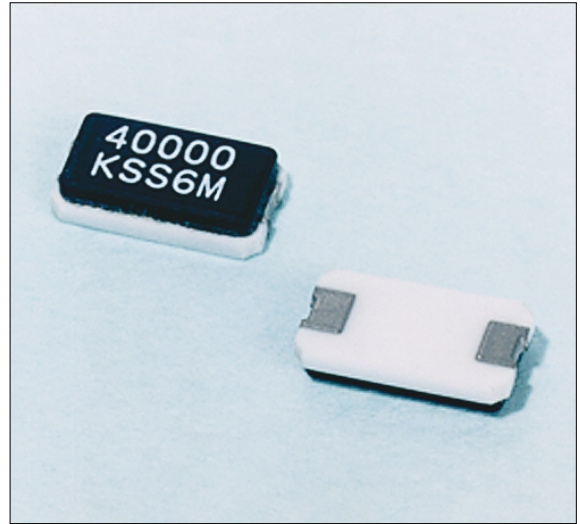

■Specifications

Type		CX-16F		
Frequency Range		12~30MHz	30.1~50MHz	30.1~70MHz
Standard Frequency		Table 1		
Overtone mode		Fundamental		3rd. O.T.
Operating Temp. Range		-10~+70°C		
Storage Temp. Range		-30~+85°C		
Frequency Tolerance	at 25°C	±50, ±100		
	Over The Oper. Temp. Range	±50, ±100×10 ⁻⁶	±100×10 ⁻⁶	±50, ±100×10 ⁻⁶
		(referred to 25°C)		
Load Capacitance		12pF *1		
Equivalent Series Resistance		50Ω MAX.		150Ω MAX.
Shock		Three drops onto a hard wood board from the height of 75cm		
Vibration		10~55Hz, amplitude 1.5mm, each to 3 directions, 30 minutes each		

■Table 1 Standard Frequencies

Standard Frequency (MHz)	
12.0000	27.0000
13.5000	29.4912
14.31818	30.0000
14.7456	32.0000
15.0000	33.0000
16.0000	33.3333
16.9344	33.8688
17.7344	36.0000
18.0000	39.3216
18.4320	40.0000
19.6608	40.3200
20.0000	48.0000
22.1184	49.1520
23.0400	50.0000
24.0000	60.0000
24.5760	66.6670
25.0000	

*1 Please inquire about load capacitance other than the above.

* Taping packaging : 1,000 or 3,000 pieces per reel

■Outline

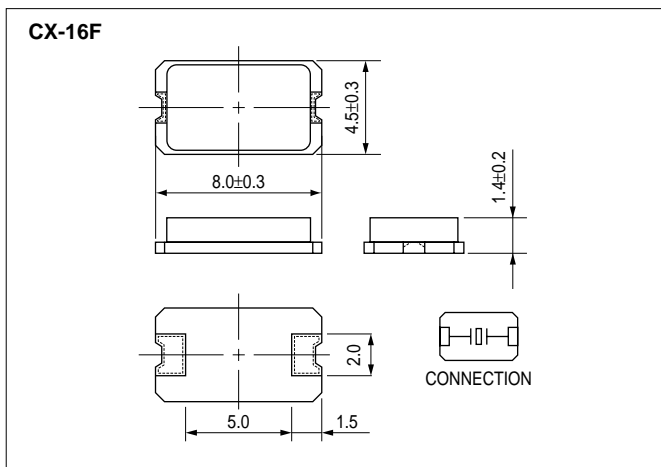

■Land Pattern(reference)

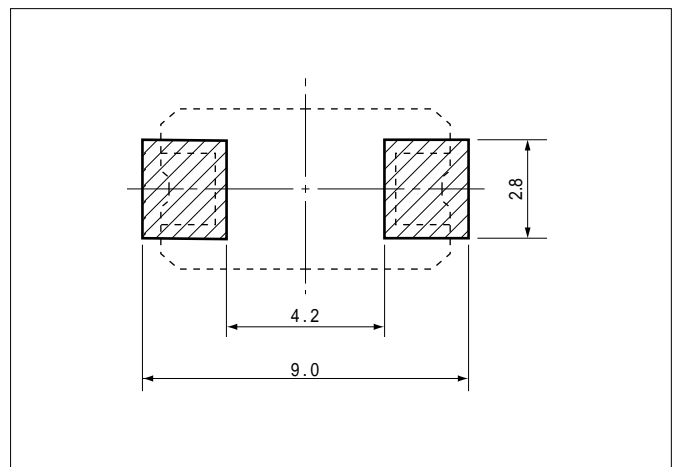



LittleDiode supplies new, hard to find or obsolete electronic components and semiconductors all over the world.

With over two million different components listed you are sure to find the part you need.

Feel free to visit us today at our online store:

LittleDiode.com

Looking forward to providing you with the best possible service.