

Capstan Motor Drive

Description

The CX20036 is a bipolar IC designed for the brushless motor drive of a 3-phase bidirectional conducting system and has the following components:

Hole element amp., Conducting angle switching circuit, Motor driver, Hole element power supply input amp., Control amp., PWM control circuit, Current limiter circuit, Voltage limiter circuit, Power saving circuit and Rotational direction switching circuit.

28 pin SOP (Plastic)

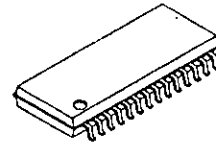

Features

- Low power consumption
- Maximum motor current: 850 mA
- PWM control circuit incorporated
- Operating power supply voltage: 4 to 9V
- Built-in current limiter
- Built-in hole element power supply
- Power saving function incorporated

Structure

Bipolar silicon monolithic IC

Absolute Maximum Ratings (Ta=25°C)

- Power supply voltage Vcc 10 V
- Operating temperature Topr -20 to +75 °C
- Storage temperature Tstg -55 to +150 °C
- Allowable power dissipation Pd 1.0 W

Recommended Operating Condition

4 to 9 V

Sony reserves the right to change products and specifications without prior notice. This information does not convey any license by any implication or otherwise under any patents or other right. Application circuits shown, if any, are typical examples illustrating the operation of the devices. Sony cannot assume responsibility for any problems arising out of the use of these circuits.

Block Diagram

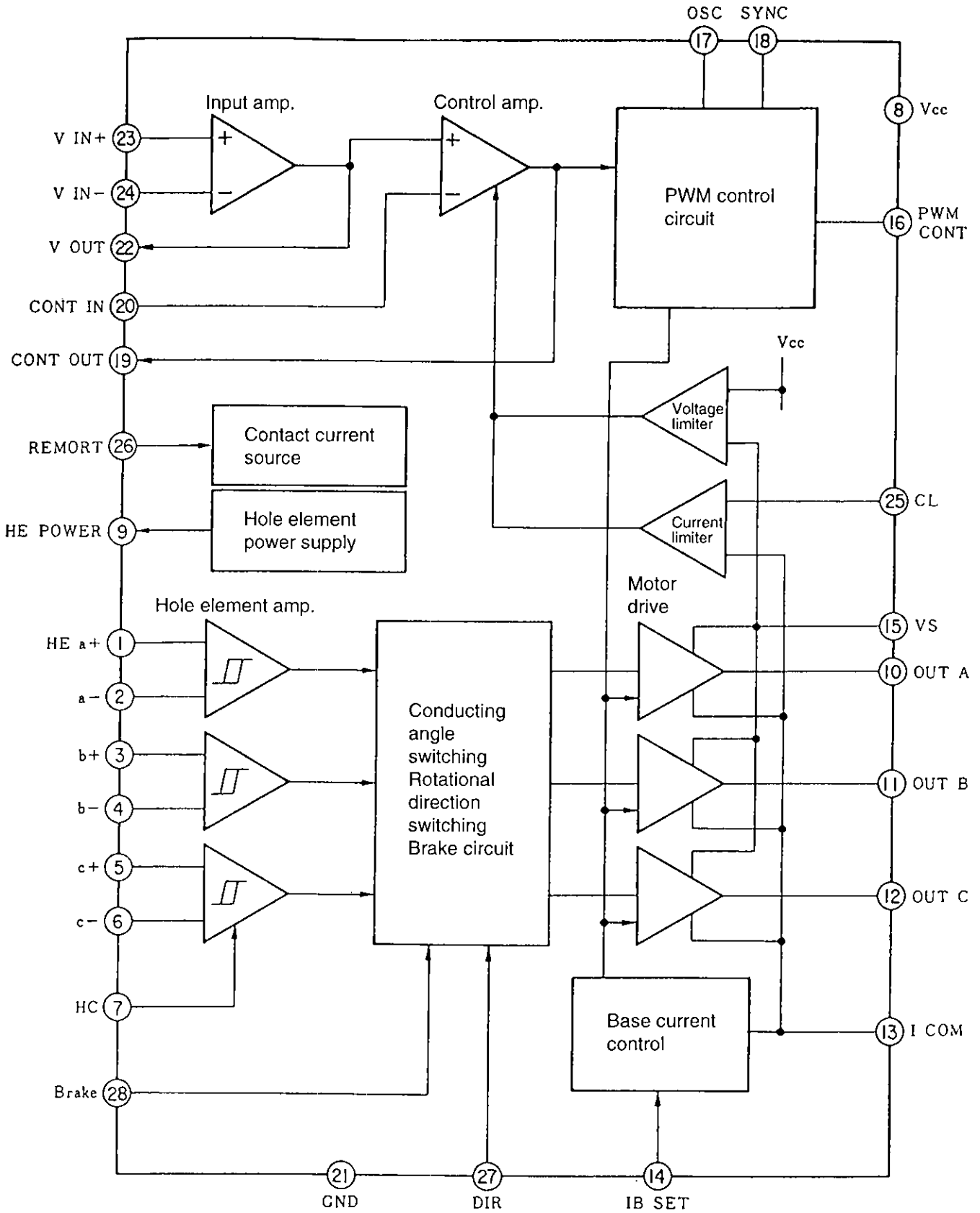

Pin Description and Equivalent Circuit

No.	Name	Function
1	HE a ⁺	Hole element amplifier input terminal with 3-phase differential input
2	HE a ⁻	
3	HE b ⁺	
4	HE b ⁻	
5	HE c ⁺	
6	HE c ⁻	
7	HC	Hysteresis cancelling terminal. Cancel by connecting to Vcc. Usually set to open.
8	Vcc	
9	HE POWER	Hole element power supply. It switches off in the power saving mode (Pin 26 → GND). Current limiter incorporated.
10	OUTPUT A	Terminal for motor connection
11	OUTPUT B	
12	OUTPUT C	
13	I COM	Monitor terminal for the motor current Voltage for setting the base current of power Tr, and current limiter
14	IB SET	Terminal for setting the base current of power Tr. $R_{14} = 1.35 \times 10^4 \text{ REF}'$, RNF': Pin 13 external resistor +50 mΩ (IC internal resistance)
15	VS	Motor input voltage terminal. Voltage after passing the PWM output through LPF is added.
16	PWMCONT	Output terminal of the PWM control signal. Power control Tr is input externally.
17	OSC	Capacitor connection terminal for setting the oscillation frequency of a PWM oscillator. Oscillation range: 50 to 200 kHz. $c = \frac{1}{f_s} \times 6.8 \times 10^7 \text{ (pF)} \quad f_s = \text{Oscillation frequency}$
18	SYNC	Input/output terminal for synchronizing the PWM oscillation frequency with an external signal or oscillation frequency
19	CONT OUT	Input/output terminal for setting the PWM loop gain with an external resistor
20	CONT IN	
21	GND	
22	V OUT	Servo signal buffer to set the servo gain with an external resistor
23	V IN ⁺	
24	V IN ⁻	

No.	Name	Function
25	CL	Maximum motor current setting terminal to input voltage externally $V_{CL} = R_{NF'} I_{ML}$ V_{CL} • Input voltage $R_{NF'}$ • Pin-13 external resistor + 50 m Ω I_{ML} • Maximum motor current
26	REMORT	Usually connected to Vcc for normal circuit operation. When connected to GND, the standby mode saves power.
27	DIR	Motor rotational direction control terminal. When connected to GND, the motor turns in reverse. Usually kept open.
28	BRAKE	Brake terminal. Current only flows in one phase and is locked. Operates when the input is at the high level. Set so that about 50 μ A is input.

Electrical Characteristics

(Ta = 25°C, Vcc = 6V. See Measurement Circuit Diagram.)

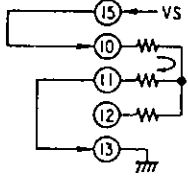
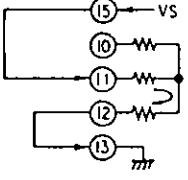
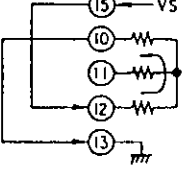
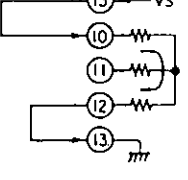
No.	Measuring item	Symbol	Measuring contents	Min.	Typ.	Max.	Unit	
1	Circuit current 1	Icc1	Current when REMOTE 26 is set to High.	3.8	5.2	6.6	mA	
2	Standby current	IccL	Standby current when REMOTE 26 is set to Low		0	6.0	μA	
3	Circuit current 2	Icc2	Circuit current when output Tr is in operation	22	33	45	mA	
4	Output saturation voltage 1U	Vsat1U	Output characteristics when one of the three phases is in operation 		300	410	mV	
5	Output saturation voltage 1L	Vsat1L				250	350	mV
6	Output current 1	IOUT1			420	470	515	mA
7	Leakage current 1	I LEAK1				0	1.6	mA
8	Common current 1	I COM1			460	500	540	mA
9	Output saturation voltage 2U	Vsat2U	Output characteristics when another phase is in operation after input signal switching 		300	410	mV	
10	Output saturation voltage 2L	Vsat2L				250	350	mV
11	Output current 2	IOUT2			420	470	515	mA
12	Leakage current 2	I LEAK2				0	1.6	mA
13	Common current 2	I COM2			460	500	540	mA
14	Output saturation voltage 3U	Vsat3U	Characteristics for each combination are as follows: 		300	410	mV	
15	Output saturation voltage 3L	Vsat3L				250	350	mV
16	Output current 3	IOUT3			420	470	515	mA
17	Leakage current 3	I LEAK3				0	1.6	mA
18	Common current 3	I COM3			460	500	540	mA
19	Output saturation voltage 4U	Vsat4U			300	410	mV	
20	Output saturation voltage 4L	Vsat4L				250	350	mV
21	Output current 4	IOUT4			420	470	515	mA
22	Leakage current 4	I LEAK4				0	1.6	mA
23	Common current 4	I COM4			460	500	540	mA

No.	Measuring item	Symbol	Measuring contents	Min.	Typ.	Max.	Unit	
24	Output saturation voltage 5U	Vsat5U			300	410	mV	
25	Output saturation voltage 5L	Vsat5L				250	350	mV
26	Output current 5	IOUT5			420	470	515	mA
27	Leakage current 5	ILEAK5				0	1.6	mA
28	Common current 5	ICOM5			460	500	540	mA
29	Output saturation voltage 6U	Vsat6U			300	410	mV	
30	Output saturation voltage 6L	Vsat6L				250	350	mV
31	Output current 6	IOUT6			420	470	515	mA
32	Leakage current 6	ILEAK6				0	1.6	mA
33	Common current 6	ICOM6			460	500	540	mA
34	Output saturation voltage difference 1	ΔV_{sat1}	$V_{sat1U} - V_{sat2U}$	-20	7	+30	mV	
35	Output saturation voltage difference 2	ΔV_{sat2}	$V_{sat2U} - V_{sat3U}$	-20	13	+30	mV	
36	Output saturation voltage difference 3	ΔV_{sat3}	$V_{sat3L} - V_{sat1L}$	-20	13	+30	mV	
37	Output saturation voltage difference 4	ΔV_{sat4}	$V_{sat1L} - V_{sat2L}$	-20	7	+30	mV	
38	Output saturation voltage 7U	Vsat7U	<p>With DIR terminal 27 set low, check the mode when the direction of rotation reverses. Input condition is same as T24 to 28 but the current is reversed.</p>		300	410	mV	
39	Output saturation voltage 7L	Vsat7L				250	350	mV
40	Output current 7	IOUT7			420	470	515	mA
41	Leakage current 7	ILEAK7				0	1.6	mA
42	Common current 7	ICOM7			460	500	540	mA

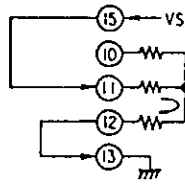
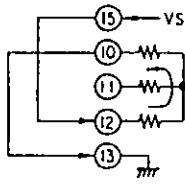
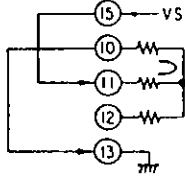
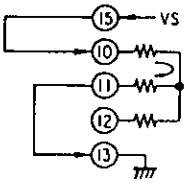
No.	Measuring item	Symbol	Measuring contents	Min.	Typ.	Max.	Unit	
43	Output saturation voltage 8U	Vsat8U	As above. Input condition same as T29 to 33. 		300	410	mV	
44	Output saturation voltage 8L	Vsat8L			250	350	mV	
45	Output current 8	IOUT8			420	470	515	mA
46	Leakage current 8	I LEAK8			0	1.6	mA	
47	Common current 8	I COM8			460	500	540	mA
48	Output saturation voltage 9U	Vsat9U	As above. Input condition same as T19 to 23. 		300	410	mV	
49	Output saturation voltage 9L	Vsat9L			250	350	mV	
50	Output current 9	IOUT9			420	470	515	mA
51	Leakage current 9	I LEAK9			0	1.6	mA	
52	Common current 9	I COM9			460	500	540	mA
53	Output saturation voltage 10UB	Vsat10UB	When BRAKE terminal pin-28 is set to Low, current only flows in one phase in any input condition. 		300	410	mV	
54	Output saturation voltage 10LB	Vsat10LB			250	350	mV	
55	Output current 10B	IOUT10B			420	470	515	mA
56	Leakage current 10B	I LEAK10B			0	1.6	mA	
57	Common current 10B	I COM10B			460	500	540	mA
58	Output saturation voltage 11UB	Vsat11UB	As above. DIR terminal low. 		300	410	mV	
59	Output saturation voltage 11LB	Vsat11LB			250	350	mV	
60	Output current 11B	IOUT11B			420	470	515	mA
61	Leakage current 11B	I LEAK11B			0	1.6	mA	
62	Common current 11B	I COM11B			460	500	540	mA
63	PWM amp test 1	TPWM1	PWM amplifier DC gain	0.90	1.00	1.10	V	
64	PWM amp test 2	TPWM2		2.70	3.00	3.40	V	
65	PWM amp test 3	TPWM3		2.00	2.20	2.45	V	
66	PWM amp test 4	TPWM4		1.60	1.87	2.10	V	

No.	Measuring item	Symbol	Measuring contents	Min.	Typ.	Max.	Unit
67	PWM amp test 5	T_{PWM5}	OSC2 100 Hz 200 mVp-p AC gain	180	200	220	mVp-p
68	PWM amp test 6	T_{PWM6}		1.90	2.10	2.30	Vp-p
69	PWM amp test 7	T_{PWM7}		360	410	440	mVp-p
70	PWM drive current 1	I_{D1}	PWM maximum drive current	31	40	58	mA
71	PWM drive current 2	I_{D2}	PWM drive off		0	10	μ A
72	PWM drive current 3	I_{D3}	Check the protection circuit when the external C is shorted.		0	10	μ A
73	PWM oscillation frequency	f_{SW}	Check OSC frequency.	70	85	110	kHz
74	Current limiter	I_{CL}	Check the current limiter operation (maximum motor current).	333	385	423	mA
75	Voltage limiter	V_L	Check the voltage limiter (when V_S is higher than V_{CC}).	5.15	5.50	5.90	V
76	HE power supply saturation voltage	V_{Hsat}	Check the saturation voltage of hole element power supply.		135	210	mV
77	HE power supply current limiter	I_{HCL}	Check the current limiter when the hole element is shorted.	9.5	16	21	mA
78	Bias current 26	I_{H26}	Pin-26 remote terminal drive current	240	305	400	μ A
79	Bias current 28	I_{L28}	Pin-28 brake terminal maximum current	0.75	1.0	1.4	mA
80	Bias current 27	I_{L27}	Pin-27 DIR drive current	-81	-62	-42	μ A
81	Bias current 25	I_{H25}	Pin-25 current limiter leakage current	-2.0	0	2.0	μ A
82	Hysteresis current A	1HA	Hole element amplifier hysteresis current A	7.8	9.7	12.5	μ A
83	Hysteresis current B	1HB	Hole element amplifier hysteresis current B	7.8	8.2	12.5	μ A
84	Hysteresis current C ₁	1HC1	Hole element amplifier hysteresis current C	7.8	8.2	12.5	μ A
85	Hysteresis current C ₂	1HC2	Hysteresis cancel operation check C	-2.0	0	2.0	μ A

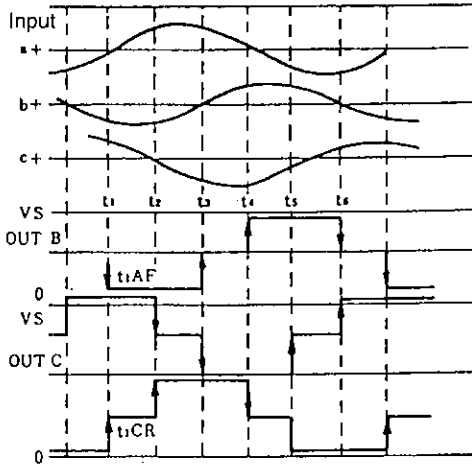
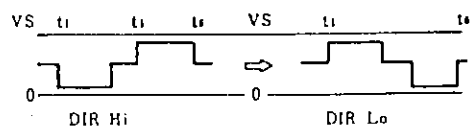
Item	Measuring item	Symbol	Measuring contents	Min.	Typ.	Max.	Unit	
86	Phase characteristics 1AF	t_{1AF}	 <p>T_{1AF} is the delay time against t₁.</p>	-15		15	μS	
87	Phase characteristics 1CR	t_{1CR}		-15		15	μS	
88	Phase characteristics 2BF	t_{2BF}		40	70	100	μS	
89	Phase characteristics 2CR	t_{2CR}		40	70	100	μS	
90	Phase characteristics 3AR	t_{3AR}		-15		15	μS	
91	Phase characteristics 3BF	t_{3BF}		-15		15	μS	
92	Phase characteristics 4AR	t_{4AR}		40	70	100	μS	
93	Phase characteristics 4CF	t_{4CF}		40	70	100	μS	
94	Phase characteristics 5BR	t_{5BR}		-15		15	μS	
95	Phase characteristics 5CF	t_{5CF}		-15		15	μS	
96	Phase characteristics 6AF	t_{6AF}		40	70	100	μS	
97	Phase characteristics 6BF	t_{6BF}		40	70	100	μS	
98	Phase characteristics 1AR	t_{1AR}		<p>Phase characteristics when reversed with DIR terminal Pin-27 set low. TIME CHART will be changed as follows by the output voltage of T86 to 97.</p> 	-15		+15	μS
99	Phase characteristics 2AR	t_{2AR}			40	70	100	μS
100	Phase characteristics 3BF	t_{3BF}	-15			+15	μS	
101	Phase characteristics 4AF	t_{4AF}	40		70	100	μS	
102	Phase characteristics 5AF	t_{5AF}	-15			15	μS	
103	Phase characteristics 6BR	t_{6BR}	40		70	100	μS	

Electrical Characteristics Measurement Condition

No.	Symbol	SW condition															Bias voltage					Mea- sure- ment point	
		1	2	3	4	5	6	7	8	9	10	11	12	13	14	15	16	E1	E2	E3	E4		E5
1	Icc1	b	b	b	b	b	a	b	b	a	a	a	a	t	a	b	1V	0V	0V	-	-	I11	
2	Iccl	↓	↓	↓	↓	↓	↓	↓	↓	↓	↓	↓	↓	b	↓	↓	↓	↓	↓	↓	↓	↓	
3	Icc2	↓	a	↓	↓	↓	↓	c	↓	↓	↓	↓	↓	a	↓	↓	↓	↓	↓	↓	↓	↓	
4	Vsat1U																					V1	
5	Vsat1L																					V5	
6	IOUT1																					V7	
7	Ileak1																					I9	
8	Icom1																					I6	
9	Vsat2U	b	b	a																			V2
10	Vsat2L																					V6	
11	IOUT2																					I8	
12	Ileak2																					I7	
13	Icom2																					I6	
14	Vsat3U	a	b	b																			V3
15	Vsat3L																					V4	
16	IOUT3																					I9	
17	Ileak3																					I8	
18	Icom3																					I6	
19	Vsat4U	b	a	a																			V1
20	Vsat4L																					V6	
21	IOUT4																					I7	
22	Ileak4																					I8	
23	Icom4																					I6	
24	Vsat5U	a	b	a																			V2
25	Vsat5L																					V4	
26	IOUT5																					I8	
27	Ileak5																					I9	
28	Icom5																					I6	
29	Vsat6U	a	a	b																			V3
30	Vsat6L																					V5	
31	IOUT6																					I9	
32	Ileak6																					I7	
33	Icom6																					I6	

No.	Symbol	SW condition																Bias voltage					Mea- sure- ment point
		1	2	3	4	5	6	7	8	9	10	11	12	13	14	15	16	E1	E2	E3	E4	E5	
34	ΔV_{sat1}	a	a	b	b	b	a	c	b	a	a	a	b	a	b	a	b	1	0	0V	-	-	
35	ΔV_{sat2}																						
36	ΔV_{sat3}																						
37	ΔV_{sat4}		↓			↓																	
38	V_{sat7U}	a	b	a		a																	
39	V_{sat7L}	↓																					
40	I_{OUT7}		↓																				
41	I_{LEAK7}		↓																				
42	I_{COM7}		↓																				
43	V_{sat8U}	a	a	b																			
44	V_{sat8L}	↓																					
45	I_{OUT8}		↓																				
46	I_{LEAK8}		↓																				
47	I_{COM8}		↓																				
48	V_{sat9U}	b	a	a																			
49	V_{sat9L}	↓																					
50	I_{OUT9}		↓																				
51	I_{LEAK9}		↓																				
52	I_{COM9}		↓			↓														↓			
53	$V_{sat10UB}$	b	b	b		b											1V	0V	5V	-	-		
54	$V_{sat10LB}$	↓																					
55	I_{OUT10B}		↓																				
56	$I_{LEAK10B}$		↓																				
57	I_{COM10B}		↓			↓														↓			
58	$V_{sat11VB}$	b	b	b		a													5V				
59	$V_{sat11LB}$	↓																					
60	I_{OUT11B}		↓																				
61	$I_{LEAK11B}$		↓																				
62	I_{COM11B}		↓		↓	↓						↓						↓	↓	↓			
63	$TPWM1$	b	b	b	b	b	a	a	a	a	a	a	a	a	b	a	a	2V	0V	0.8			V10
64	$TPWM2$						↓																V11
65	$TPWM3$			↓								↓								↓		V8	
66	$TPWM4$	↓	↓	a	↓	↓			b			b				b	↓	↓	↓	-	↓	V7	

No.	Symbol	SW condition																Bias voltage					Mea- sure- ment point
		1	2	3	4	5	6	7	8	9	10	11	12	13	14	15	16	E1	E2	E3	E4	E5	
67	TPWM5	b	b	b a	b	b	a	a	b	a	a	a	b	a	b	a b	b a	1V	2V	0V	- 0.7V	-	V10
68	TPWM6			↓																		V11	
69	TPWM7			a			↓	↓			↓					↓	b				↓	↓	V7
70	ID1			b			b	b			d					a	a				0V	375mV	I10
71	ID2												↓								2V		I10
72	ID3												a								0V		I10
73	fsw			↓			↓	↓			↓			b			↓	↓	↓		0.8V	↓	TP4
74	ICL			a			a	a		↓	a	↓				b	b	0.2V	4V		-	-	I6
75	VL			↓				↓		b	b	b			↓			1V	↓				V7
76	VHSAT			b				b		a	a	a			a				0V				V9
77	IHCL														c								I13
78	IH26														b						↓		
79	IL28					↓														5V			
80	IL27					a														0V			
81	IB25	↓				b																	
82	IHA	a	↓																				
83	IHB	b	a	↓																			
84	IHC1			a	↓																		
85	IHC2	↓	↓	↓	a			↓											↓				
86	t1AF	c	c	c	b			a											3V				TP1
87	t2CR																						TP3
88	t2BF																						TP2
89	t3CR																						TP3
90	t3AR																						TP1
91	t4BF																						TP2
92	t4AR																						TP1
93	t5CF																						TP3
94	t5BR																						TP2
95	t6CF																						TP3
96	t6AF																						TP1
97	t1BF					↓															↓	↓	TP2
98	t2AR					b a															-	-	TP1
99	t3AR																						↓
100	t4BF																						TP2
101	t5AF																						TP1
102	t5AF																						↓
103	t6BR	↓	↓	↓	↓	↓	↓	↓	↓	↓	↓	↓	↓	↓	↓	↓	↓	↓	↓	↓	↓	↓	TP2

Electrical Characteristics Measurement Circuit

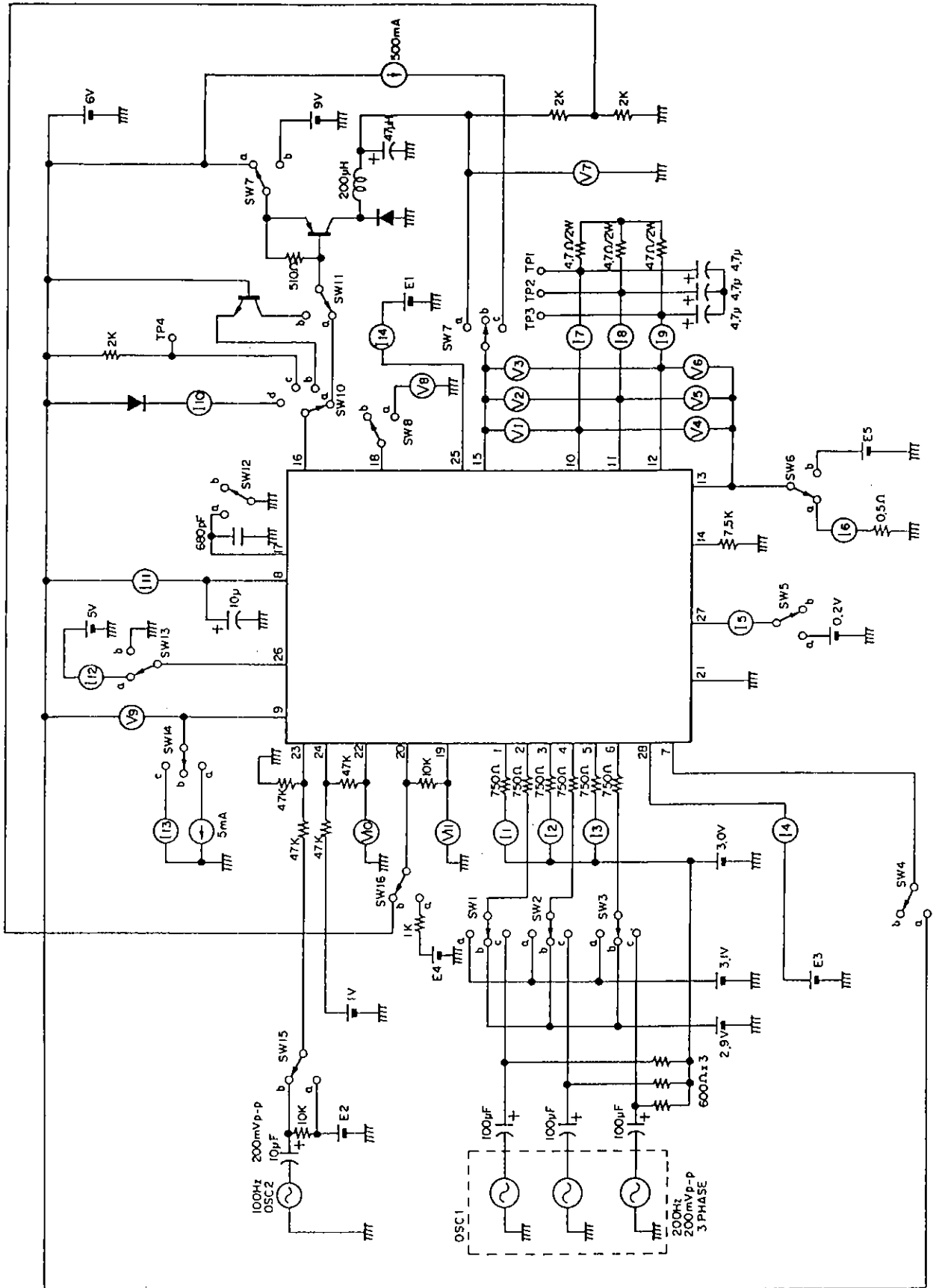

Standard Circuit Design Reference Truth Table

HE input a	HE input b	HE input c	DIR	OUTPUT A	OUTPUT B	OUTPUT C
H	L	H	H	L	H	OFF
H	L	L	H	L	OFF	H
H	H	L	H	OFF	L	H
L	H	L	H	H	L	OFF
L	H	H	H	H	OFF	L
L	L	H	H	OFF	H	L
H	L	H	L	H	L	OFF
H	L	L	L	H	OFF	L
H	H	L	L	OFF	H	L
L	H	L	L	L	H	OFF
L	H	H	L	L	OFF	H
L	L	H	L	OFF	L	H

Standard Terminal Voltage *External input

Pin No.	Pin Voltage	Pin No.	Pin Voltage
1	* 0.3 to Vcc-1.5V	15	* 1 to Vcc
2	* 0.3 to Vcc-1.5V	16	1 to Vcc
3	* 0.3 to Vcc-1.5V	17	
4	* 0.3 to Vcc-1.5V	18	
5	* 0.3 to Vcc-1.5V	19	1 to Vcc-1V
6	* 0.3 to Vcc-1.5V	20	* 0 to Vcc-2V
7	Vcc-0.7	21	GND
8	* Vcc	22	* 0.15 to Vcc-0.7
9	Vcc-0.25	23	* 0.3 to Vcc-1.5
10	0 to Vs	24	* 0.3 to Vcc-1.5
11	0 to Vs	25	* 0 to Vcc-2V
12	0 to Vs	26	* 0 or Vcc
13	0 to 0.4	27	* 0 or 1V (open)
14	0 to 0.4	28	* 0 or 1V (when current supply is connected)

Application Circuit Example

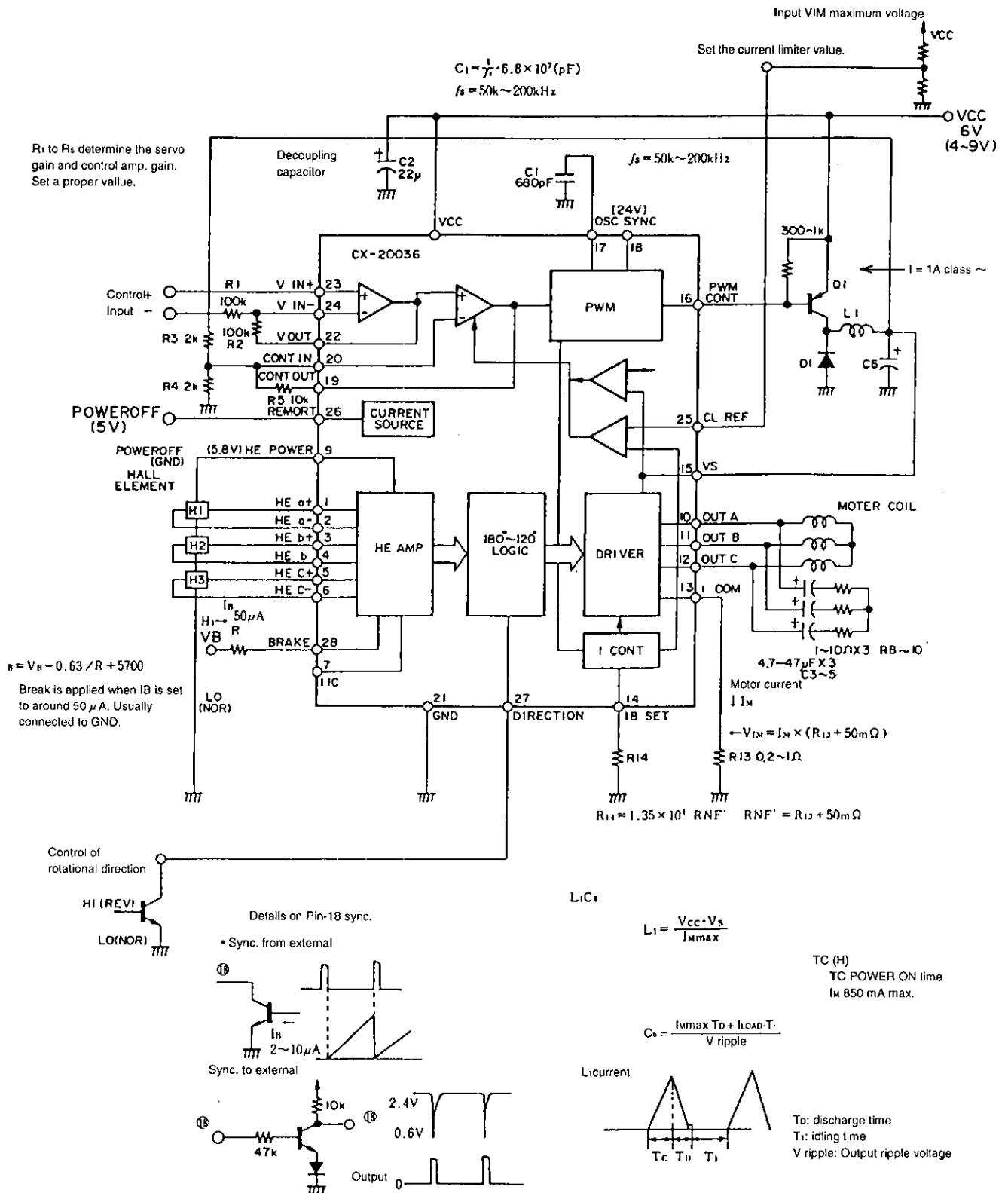

Application circuits shown are typical examples illustrating the operation of the devices. Sony cannot assume responsibility for any problems arising out of the use of these circuits or for any infringement of third party patent and other right due to same.

Output Saturation Voltage vs. IBSET Resistance

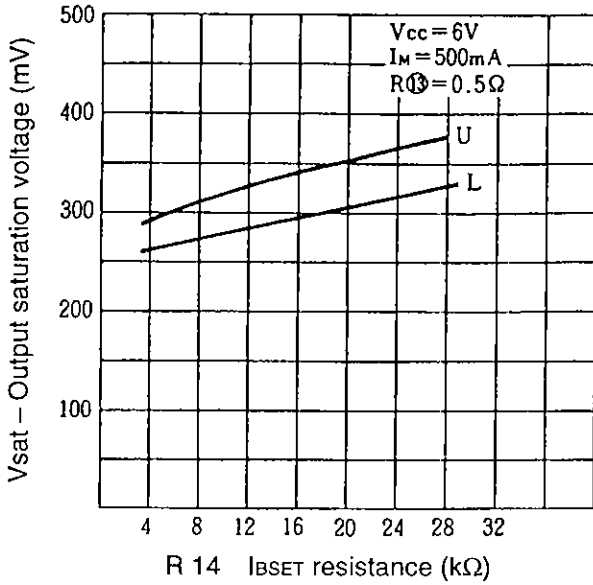

Circuit Current vs. IBSET Resistance

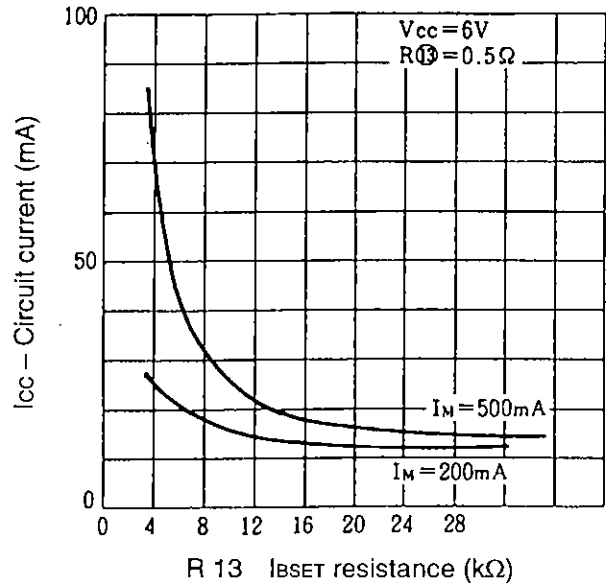

Circuit Current vs. Power Supply Voltage

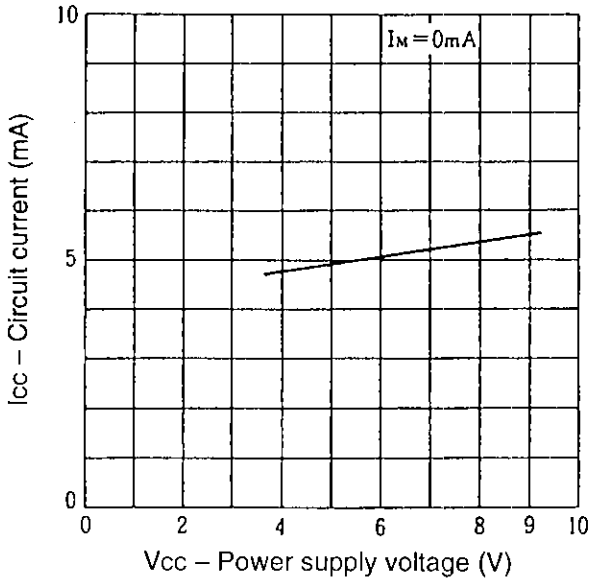

Output Saturation Voltage vs. Output Current

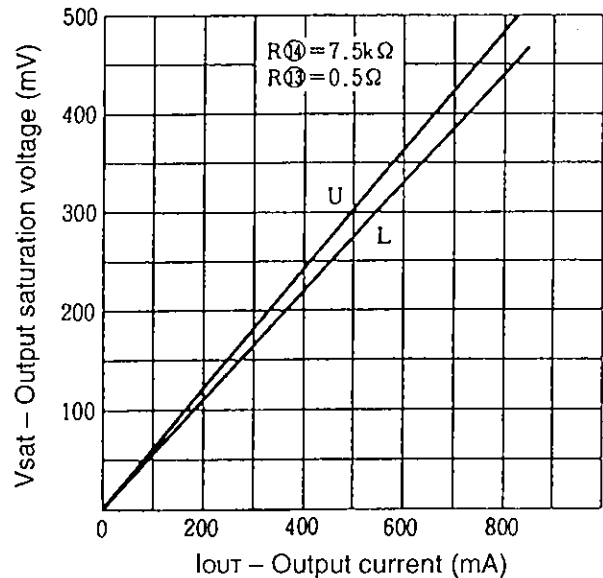

Circuit Current vs. Ambient Temperature

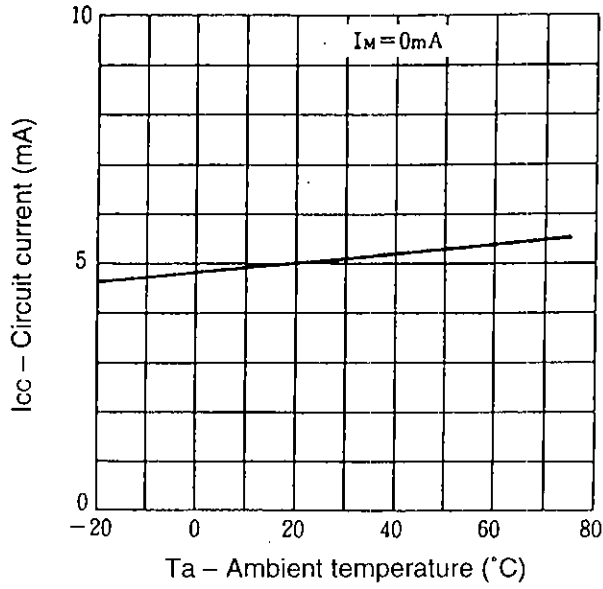

Output Saturation Voltage vs. Ambient Temperature

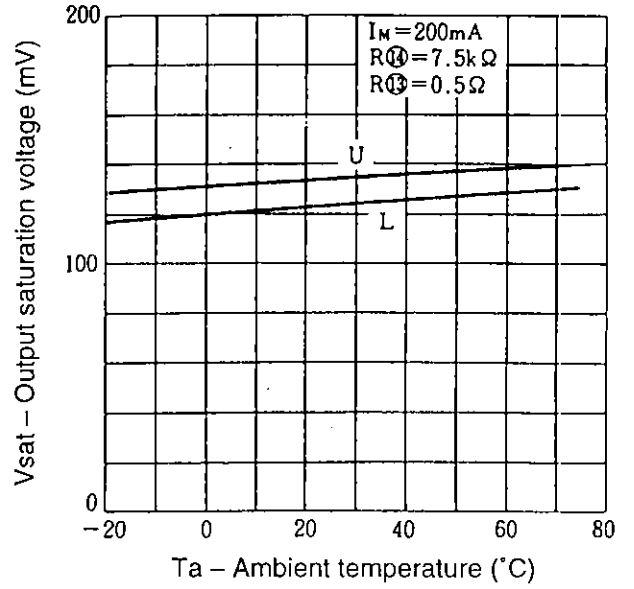

PWM Oscillation Frequency vs. Power Supply Voltage

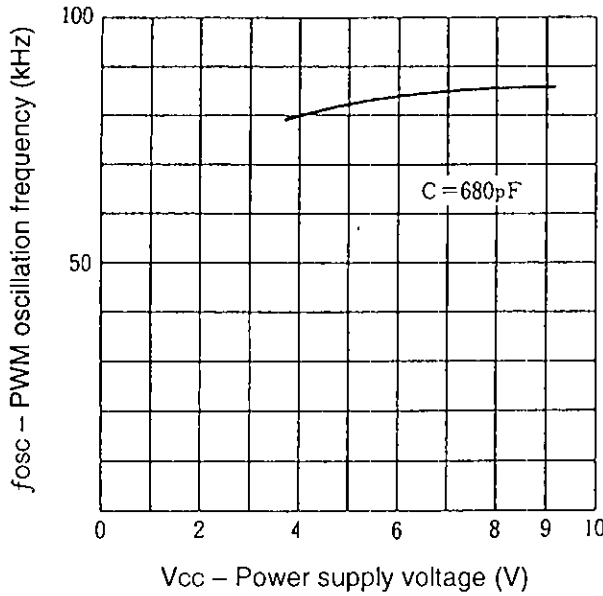

PWM Oscillation Frequency vs. Ambient Temperature

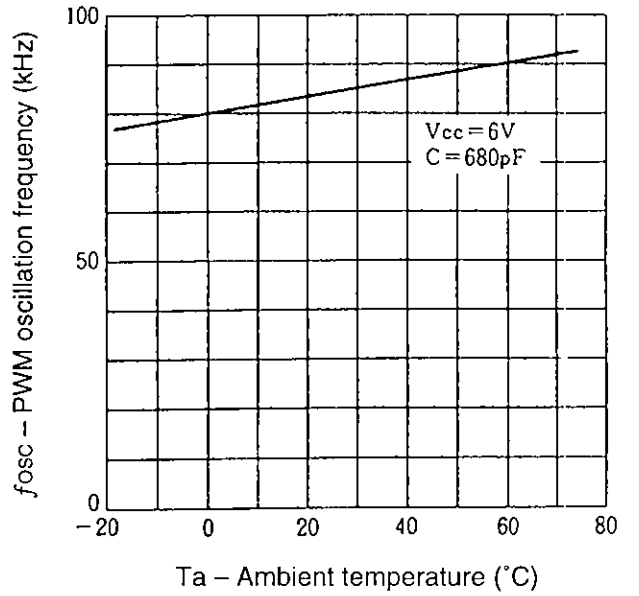

PWM Oscillation Frequency vs. C 17

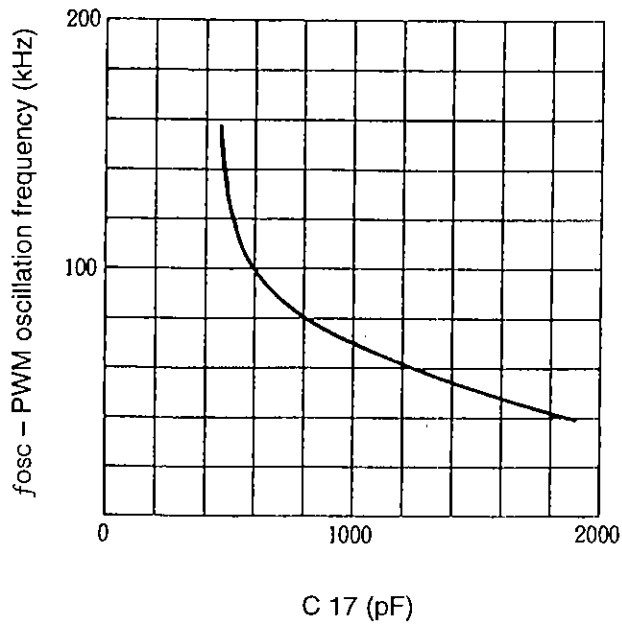

Transit Thermal Resistance vs. Time

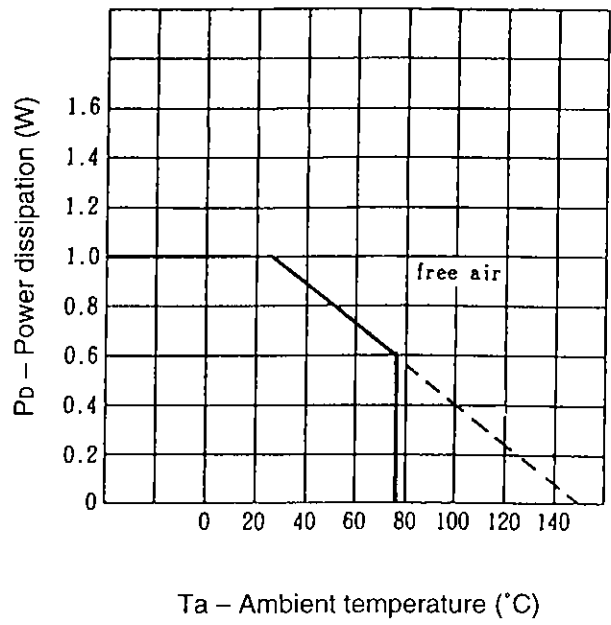

Allowable Power Dissipation Decrement Curve

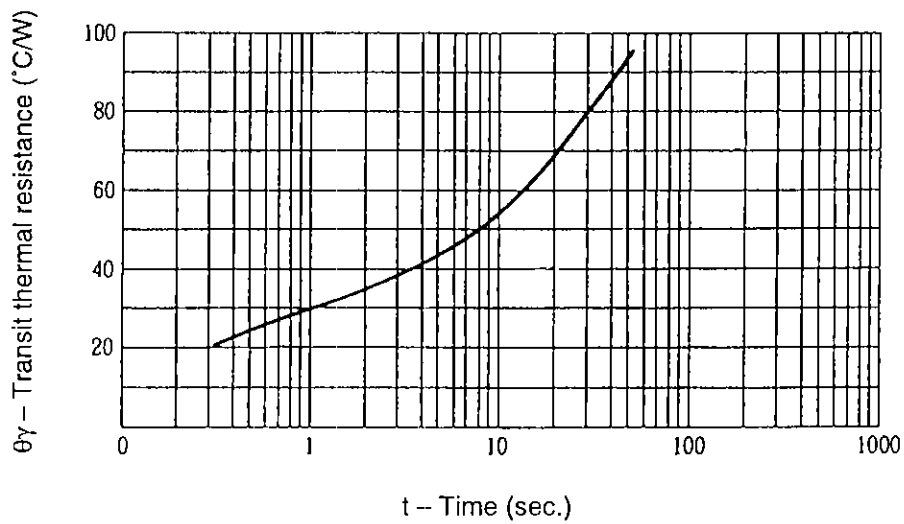

Package Outline Unit : mm

28PIN SOP (PLASTIC) 375MIL

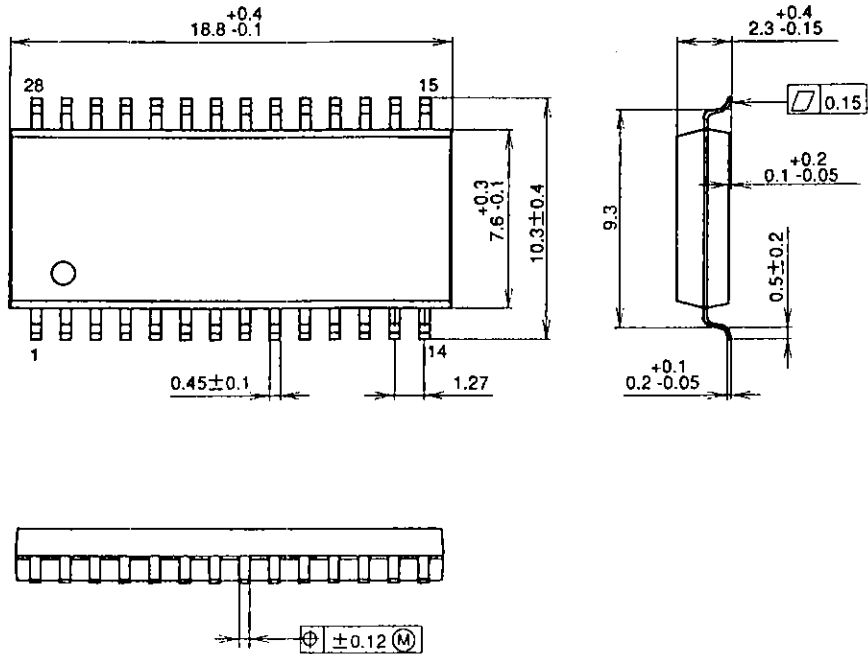

PACKAGE STRUCTURE

SONY CODE	SOP-28P-L04
EIAJ CODE	*SOP028-P-0375-D
JEDEC CODE	_____

PACKAGE MATERIAL	EPOXY RESIN
LEAD TREATMENT	SOLDER PLATING
LEAD MATERIAL	42 ALLOY
PACKAGE WEIGHT	0.7g



LittleDiode supplies new, hard to find or obsolete electronic components and semiconductors all over the world.

With over two million different components listed you are sure to find the part you need.

Feel free to visit us today at our online store:

LittleDiode.com

Looking forward to providing you with the best possible service.