

**8-bit 20 MSPS Flash A/D Converter (TTL I/O)**

**Description**

The CXA1096M is an 8-bit 20 MSPS high speed A/D converter IC. This IC is suitable for a wide range of applications where A/D high speed operation is required.

**Features**

- Resolution 8-bit  $\pm 1/2$  LSB
- High speed operation 20MSPS
- Wide band analog input 8MHz ( $-3$ dB)
- Low input capacitance 30pF (Typ.)
- Low power consumption 390mW (Typ.)
- I/O level TTL
- Two ways of power supply (Single +5V or dual +5V/-5.2V)
- Sample and Hold amplifier not required
- Binary or Two's complement mode
- Over range output

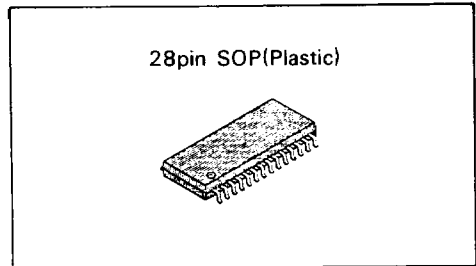

**Structure**

Bipolar silicon monolithic IC

**Applications**

- Digital TV
- High speed signal processing

**Function**

8-bit, 20MSPS flash A/D converter

**Block Diagram**

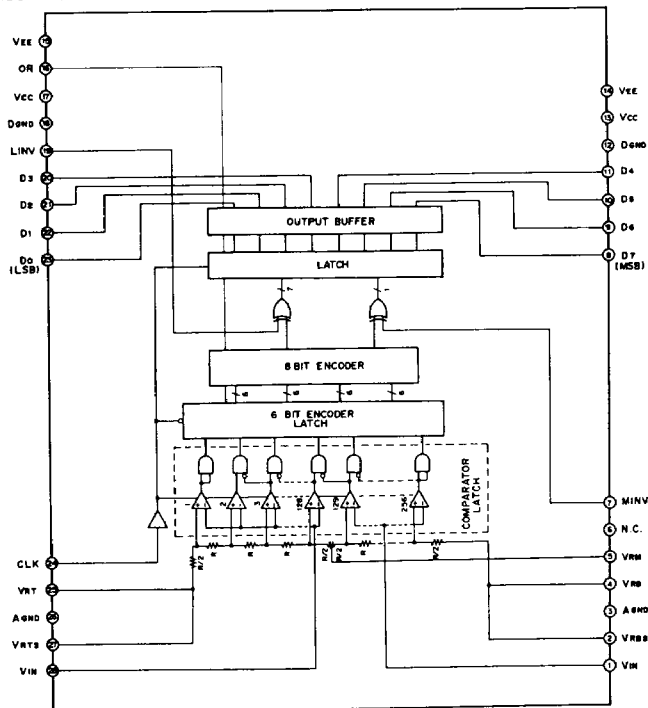

**Absolute Maximum Ratings (Ta = 25°C)**

• Supply voltage	VCC—DGND	0 to +6	V
	VEE—AGND	0 to -6	V
	AGND—DGND	0 to +6	V
• Input voltage(analog)	VIN	VEE to AGND +0.3	V
• Input voltage (reference)	VRT, VRB, VRM	VEE to AGND +0.3	V
	VRT - VRB	2.5	V
• Input current (VRM)	IVRM	-3 to +3	mA
• Input voltage (digital)	CLK, MINV, LINV	DGND-0.5 to VCC	V
• Storage temperature	Tstg	-55 to +150	°C
• Allowable power dissipation	PD	0.83	W

**Recommended Operating Conditions**

• Supply voltage (Single supply)	VCC, AGND	4.75 to 5.25	V
	DGND, VEE	0	V
• (Dual supply)	VCC	4.75 to 5.25	V
	VEE	-5.5 to -4.75	V
	DGND, AGND	0	V
• Reference input	VRT	AGND -0.1 to AGND +0.1	V
	VRB	AGND -2.2 to AGND -1.8	V
• Analog input	VIN	VRB to VRT	
• Clock pulse width	TPW1	35 (Min.)	ns
	TPW0	10 (Min.)	ns
• Operating temperature	Topr	-20 to +75	°C

Pin Description and Equivalent Circuit

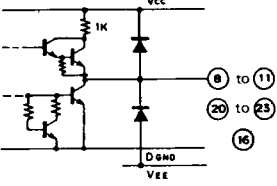
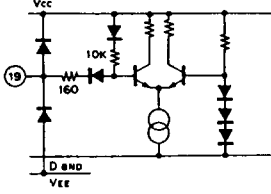
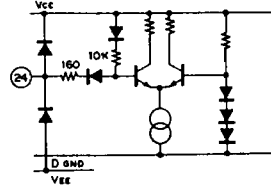
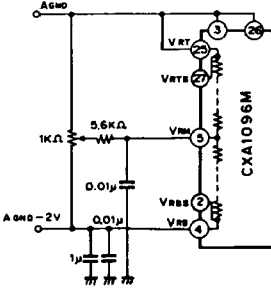
No.	Symbol	Voltage	Equivalent circuit	Description
8 to 11 20 to 23	D0 to D7	TTL		Digital data output pin D0 (LSB) to D7 (MSB)
16	OR			Over range output pin
12, 18	DGND	GND		Digital GND Separated from AGND
13, 17	Vcc	5V (Typ)		Digital power supply
14, 15	VEE	GND (Single supply) - 5V (Dual supply)		Analog power supply
19	LINV	TTL		Input pins for output polarity inversion of D0 (LSB) to D6 (See the Input-Output Reference and Output Format) when open "1" is maintained
24	CLK	TTL		Clock input pin
25	VRT	5V (Typ) (Single supply)		Reference voltage (Top)
27	VRTS	GND (Dual supply)		Reference voltage sense (Top)
4	VRB	3V (Typ.) (Single supply) - 2V (Typ.) (Dual supply)		Reference voltage (Bottom)
2	VRBS			Reference voltage sense (Bottom)
5	VRM	4V (Typ.) (Single supply) - 1V (Typ.) (Dual supply)		Middle point of reference voltage can be used as the compensation pin for linearity

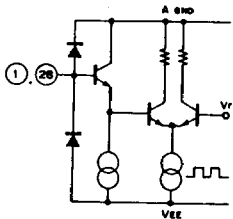
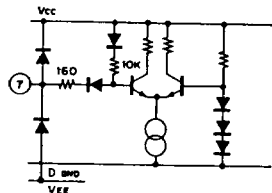
No.	Symbol	Voltage	Equivalent circuit	Description
3, 26	AGND	5V (Typ.) (Single supply) GND (Dual supply)		Analog power supply
1, 28	VIN	VRT to VRB		Analog input Pin 1 and 28 should be connected together.
7	MINV	TTL		Input pin for output polarity inversion of D7 (MSB) when open "1" is maintained.

3

Input-Output Reference and Output Format

Vin	Step	MINV	1	1	0	0		
		LINV	1	0	1	0	OR MSB	LSB
AGND	0	0	000...00	0 011...11	0 100...00	0 111...11	OR MSB	LSB
		1	000...00	1 011...11	1 100...00	1 111...11	OR MSB	LSB
		1	000...01	1 011...10	1 100...01	1 111...10	OR MSB	LSB
AGND -1V	127	1	011...11	1 000...00	1 111...11	1 100...00	OR MSB	LSB
		128	1 100...00	1 111...11	1 000...00	1 011...11	OR MSB	LSB
AGND -2V	254	1	111...10	1 100...01	1 011...10	1 000...01	OR MSB	LSB
		255	1 111...11	1 100...00	1 011...11	1 000...00	OR MSB	LSB
		1	111...11	1 100...00	1 011...11	1 000...00	OR MSB	LSB

1: VIH, VOH  
0: VIL, VOL

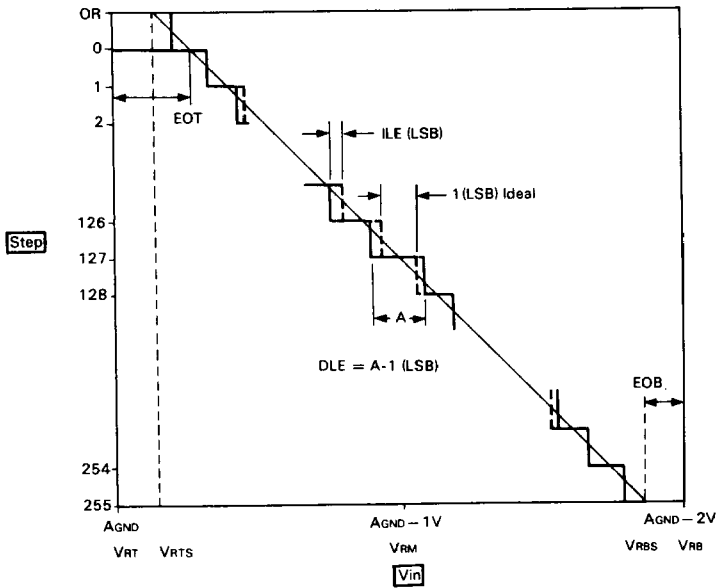

**Electrical Characteristics  
(Single supply)**

VCC = +5V, DGND = 0V, AGND = +5V, VEE = 0V,  
VRT = +5V, VRB = +3V, Ta = 25°C

Item	Symbol	Test condition	Min.	Typ.	Max.	Unit	
Maximum conversion rate	F <sub>C</sub>	V <sub>IN</sub> = 5 to 3V F <sub>IN</sub> = F <sub>C</sub> /4 - 1 kHz	20			MSPS	
Supply current	I <sub>CC</sub> + I <sub>EE</sub>		56	71	91	mA	
Reference pin current	I <sub>REF</sub>		11	15	18	mA	
Analog input bandwidth	BW		8			MHz	
Analog input capacitance	C <sub>IN</sub>	V <sub>IN</sub> = 4V + 0.07V <sub>rms</sub>		30	35	pF	
Analog input bias current	I <sub>IN</sub>	V <sub>IN</sub> = 4V	15	50	110	μA	
Reference resistance (VRT to VRB)	R <sub>REF</sub>			130		Ω	
Offset voltage	V <sub>RT</sub>	E <sub>OT</sub>	8	13	19	mV	
	V <sub>RB</sub>	E <sub>OB</sub>	0	5	11	mV	
Digital input voltage	V <sub>IH</sub>		2.0			V	
	V <sub>IL</sub>				0.8	V	
Digital input current	I <sub>IH</sub>	V <sub>CC</sub> = Max.	V <sub>IH</sub> = 2.7V	0	-100	-150	μA
	I <sub>IL</sub>		V <sub>IL</sub> = 0.5V	-0.1	-0.32	-0.5	mA
Digital output voltage	V <sub>OH</sub>	V <sub>CC</sub> = Min.	I <sub>OH</sub> = -500μA	2.7	3.4		V
	V <sub>OL</sub>		I <sub>OL</sub> = 3mA			0.5	V
Output data delay	T <sub>DLH</sub>	LOAD 1		15	19	22	ns
	T <sub>DHL</sub>			22	27	31	ns
Non linearity	EL	F <sub>C</sub> = 20 MSPS V <sub>IN</sub> = 5 to 3V			± 1/2	LSB	
Differential non linearity	ED				± 1/2	LSB	
Differential gain error	DG	NTSC 40 IRE mod. ramp, F <sub>C</sub> = 14.3 MSPS			1.5	%	
Differential phase error	DP				0.5	deg.	
Aperture jitter	E <sub>AP</sub>			30		ps	
Sampling delay	t <sub>ds</sub>		5	7	9	ns	

3

**Electrical Characteristics**  
**(Dual supply)**
 $V_{CC} = +5V$ ,  $DGND = 0V$ ,  $AGND = 0V$ ,  $V_{EE} = -5V$ ,  
 $V_{RT} = 0V$ ,  $V_{RB} = -2V$ ,  $T_a = 25^\circ C$ 

Item	Symbol	Test condition		Min.	Typ.	Max.	Unit
Maximum conversion rate	FC	$V_{IN} = 0$ to $-2V$ $F_{IN} = F_C/4 - 1$ kHz		20			MSPS
Supply current	$I_{CC}$			7	10	14	mA
	$I_{EE}$			50	62	78	mA
Reference pin current	$I_{REF}$			11	15	18	mA
Analog input bandwidth	BW			8			MHz
Analog input capacitance	$C_{IN}$	$V_{IN} = -1V + 0.07V_{rms}$			30	35	pF
Analog input bias current	$I_{IN}$	$V_{IN} = -1V$		15	50	110	$\mu A$
Reference resistance ( $V_{RT}$ to $V_{RB}$ )	$R_{REF}$				130		$\Omega$
Offset voltage	$V_{RT}$	$E_{OT}$		8	13	19	mV
	$V_{RB}$	$E_{OB}$		0	5	11	mV
Digital input voltage	$V_{IH}$			2.0			V
	$V_{IL}$					0.8	V
Digital input current	$I_{IH}$	$V_{CC} = \text{Max.}$	$V_{IH} = 2.7V$	0	-100	-150	$\mu A$
	$I_{IL}$		$V_{IL} = 0.5V$	-0.1	-0.32	-0.5	mA
Digital output voltage	$V_{OH}$	$V_{CC} = \text{Min.}$	$I_{OH} = -500\mu A$	2.7	3.4		V
	$V_{OL}$		$I_{OL} = 3mA$			0.5	V
Output data delay	$T_{DLH}$	LOAD 1		15	19	22	ns
	$T_{DHL}$			22	27	31	ns
Non linearity	EL	$F_C = 20$ MSPS $V_{IN} = 0$ to $-2V$				$\pm 1/2$	LSB
Differential non linearity	ED					$\pm 1/2$	LSB
Differential gain error	DG	NTSC 40 IRE mod. ramp, $F_C = 14.3$ MSPS				1.5	%
Differential phase error	DP					0.5	deg.
Aperture jitter	EAP				30		ps
Sampling delay	tds			5	7	9	ns

Application Circuit and Electrical Characteristics Test Circuit  
Single supply

1)

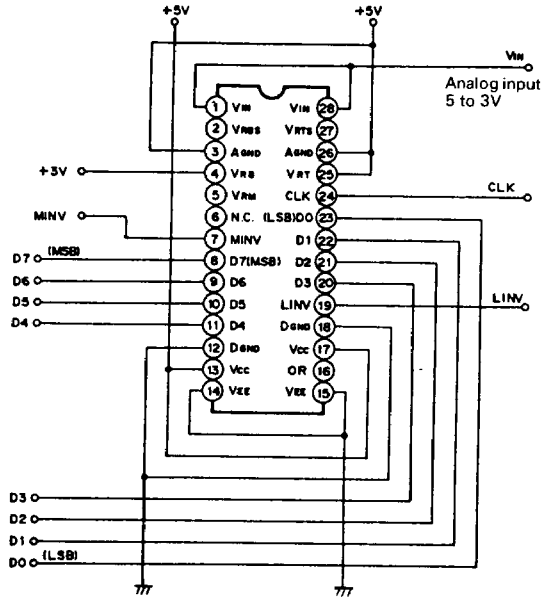

Dual supply

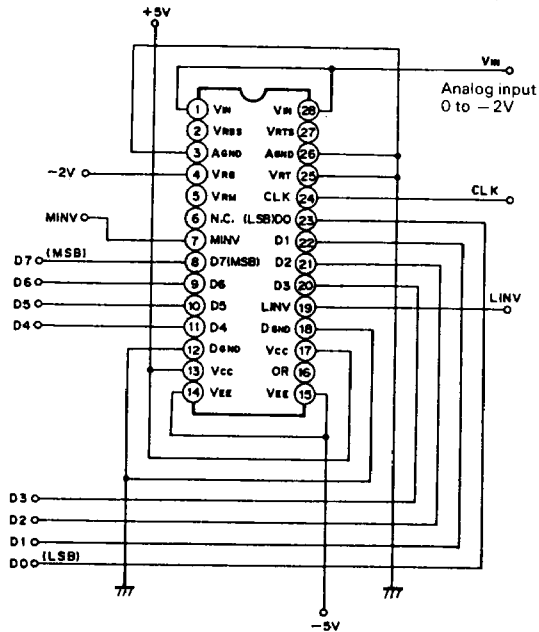

3

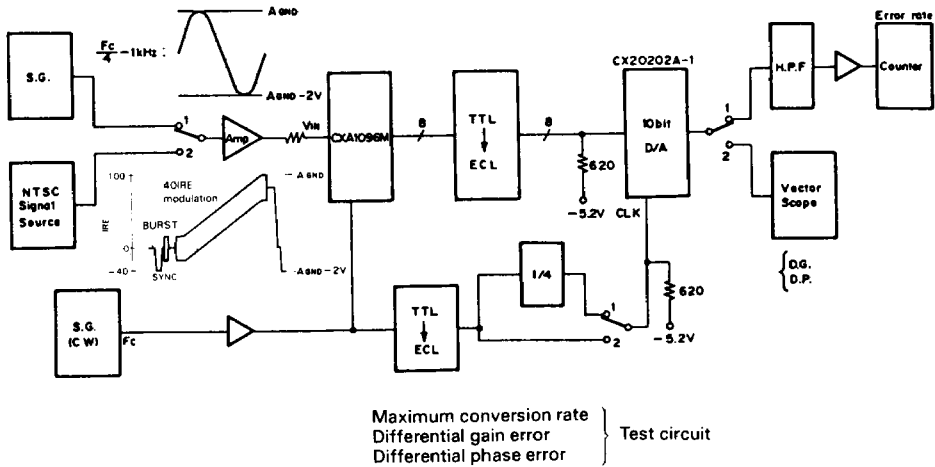
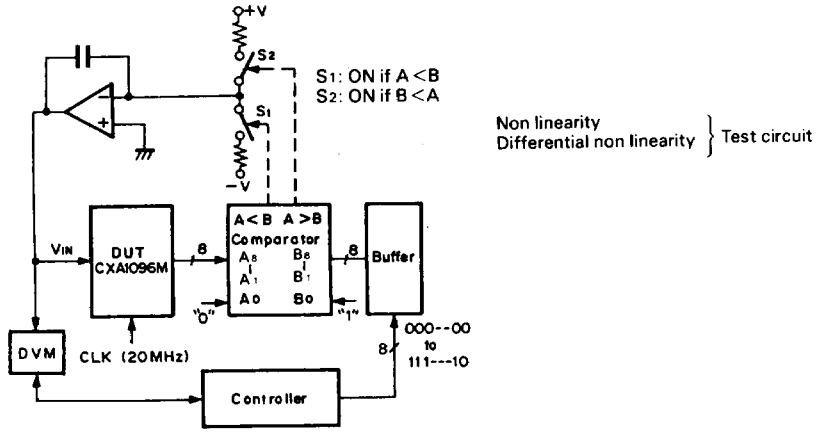

2)

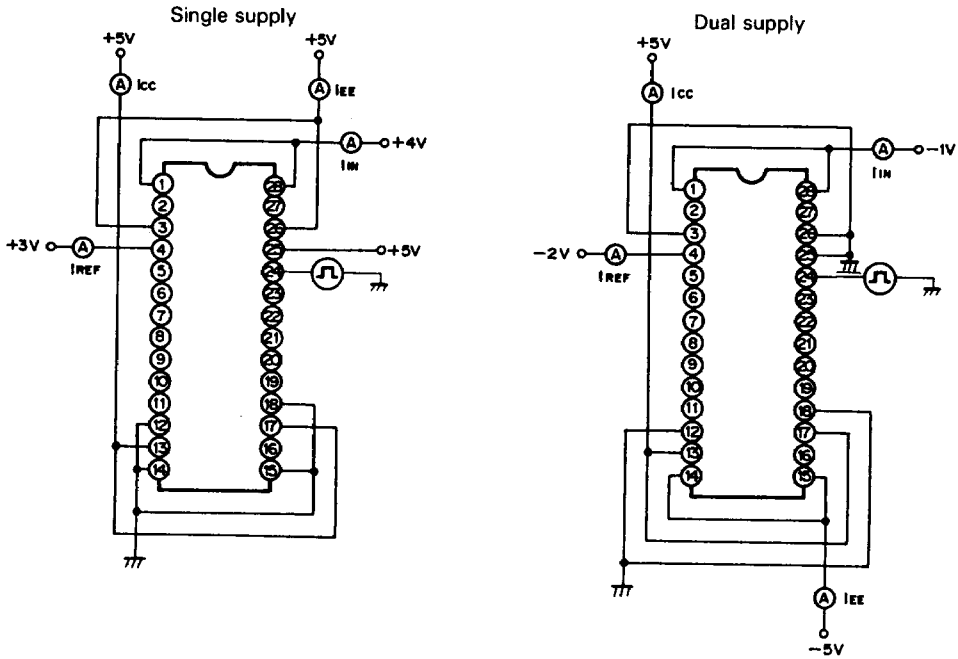

3

**Note)** VIN pin is connected to VRT pin for ICC and IEE measurement.

Supply current  
 Analog input bias current  
 Reference pin current } Test circuit

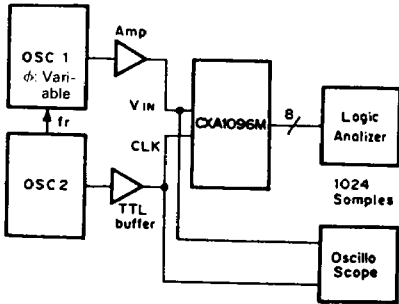

Aperture jitter  
 Sampling delay } Test circuit

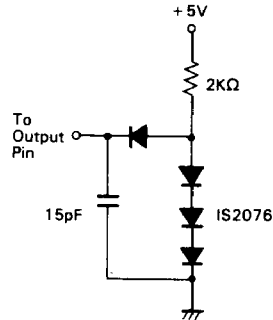

LOAD1 Test Load for Output data delay

3)

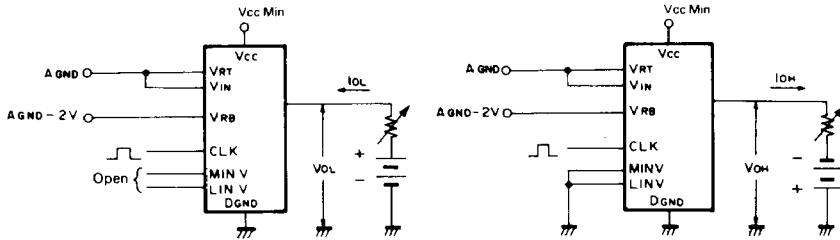

Test circuit of digital output voltage (D0 to D7, OR)

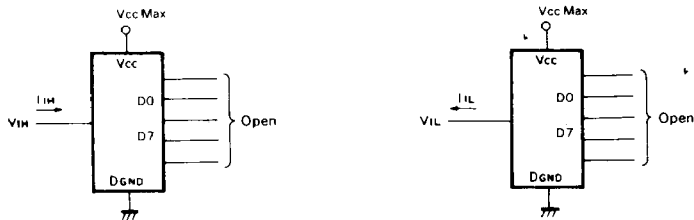

Test circuit of digital input current (CLK, MINV, LINV)

Timing Chart

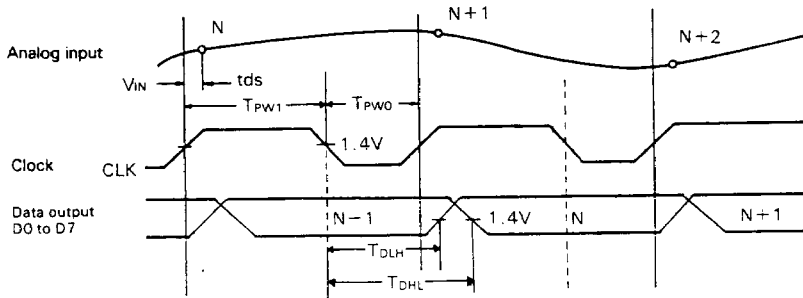

Application Circuit (Single supply)

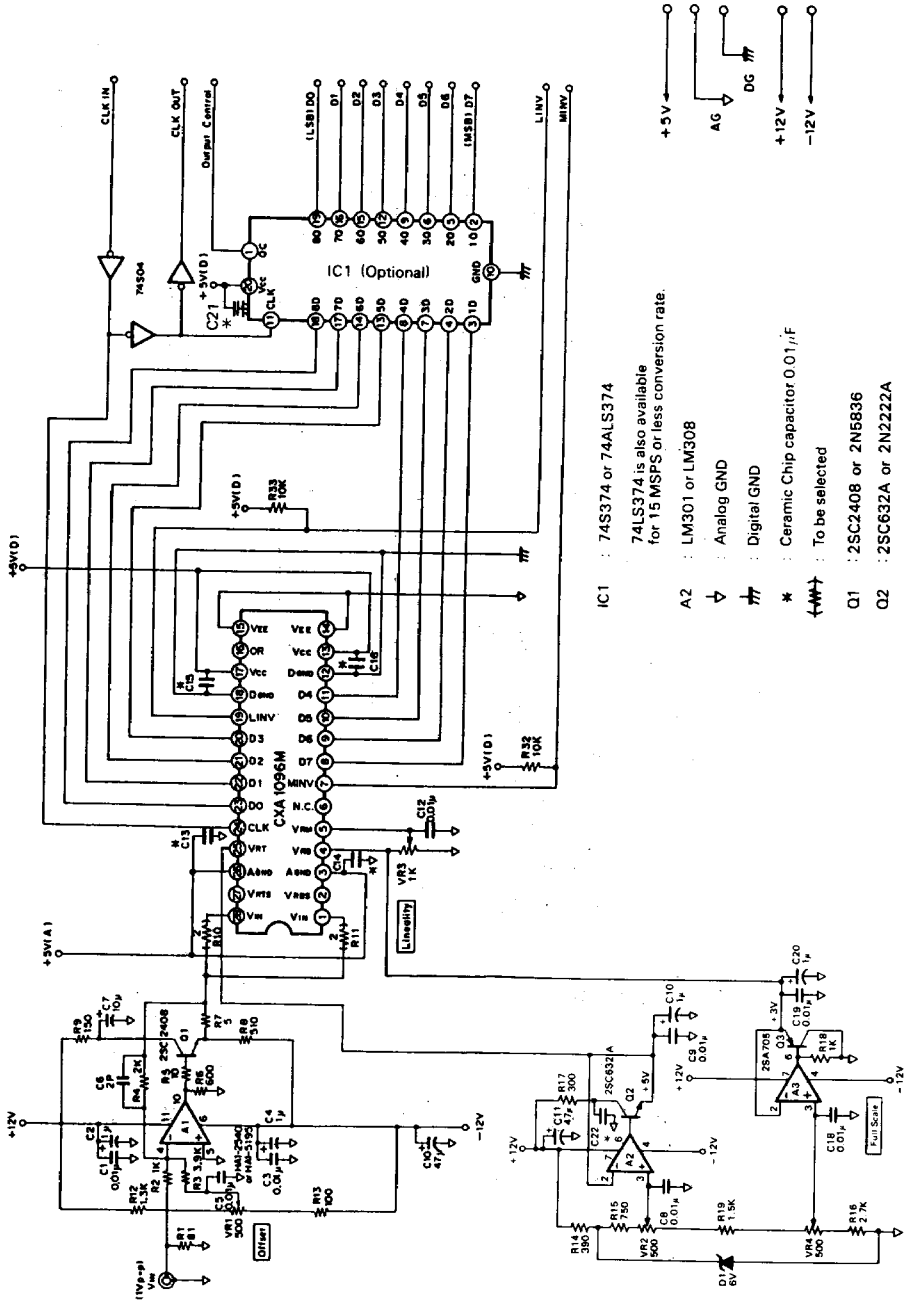

- IC1 : 74S374 or 74ALS374  
74ALS374 is also available for 15 MSPS or less conversion rate.
- A2 : LM301 or LM308
- ∇ : Analog GND
- ⚡ : Digital GND
- \* : Ceramic Chip capacitor 0.01 $\mu$ F
- ⚡⚡ : To be selected
- Q1 : 25C2408 or 2N6836
- Q2 : 25C632A or 2N2222A
- Q3 : 2SA705 or 2N2907A





## Notes on Application

- Each of DGND pins (12, 18) and each of VCC Pins (13, 17) are divided in internal circuit. All of the pins should be connected to respective PCB patterns.
- Layout of the analog and digital sections should be separated to reduce noise effect.  
VEE pins to AGND and VCC pins to DGND should be bypassed as closely as possible by means of  $1\mu\text{F}$  and  $0.01\mu\text{F}$  capacitors.  
For the  $0.01\mu\text{F}$ , a ceramic chip capacitor should be used.
- The input capacitance of the analog input is much smaller than that of the Flash Type A/D converters in use so far. It is necessary to use an amplifier with sufficient band width and driving power.  
Pins VIN (1, 28) are divided in it, so they should be connected together. When driving with a low output impedance amplifier, parasitic oscillation may occur. This can be prevented by introducing between the amplifier output and A/D input a small resistance of 2 to  $10\Omega$  with smaller inductance, in series. And, that also each VIN pins are divided with small resistances (shown in the Application Circuit) is effective.  
The amplifier output and A/D input should be connected as closely as possible.
- Voltage between VRT to VRB is equivalent to the dynamic range of the analog input. VRB pin should be bypassed to AGND by means of  $1\mu\text{F}$  and  $0.01\mu\text{F}$  capacitors.  
Through bypassing VRM pin with a  $0.01\mu\text{F}$  capacitor to AGND, characteristics at high frequency become more balanced. Also, VRM pin can be used as a trimming pin for more precise linearity compensation.
- CLK line should be wired in short distance and that should be separated from the other section to reduce the inductive.
- Analog input signal is sampled at the positive going edge of the CLK, and a corresponding digital data appears to the output parts at the negative going edge with a short delay time (TDLH, TDHL).  
If digital data will be latched externally, it should be latched at the negative going edge. (See the Timing Chart)
- It is recommended to connect free pins to AGND for prevention of noise effect.

3

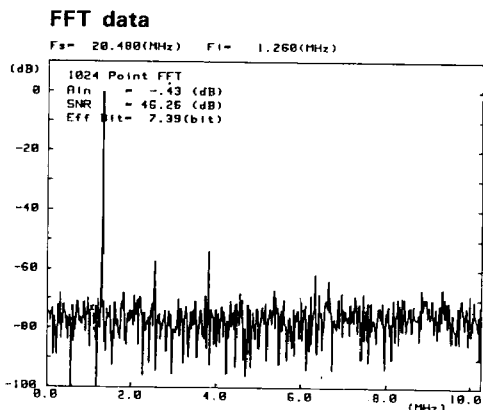

**Fc max vs. Ambient temperature**

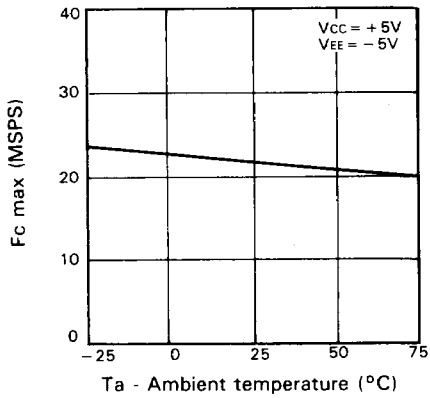

**CIN vs. VIN - Input DC level**

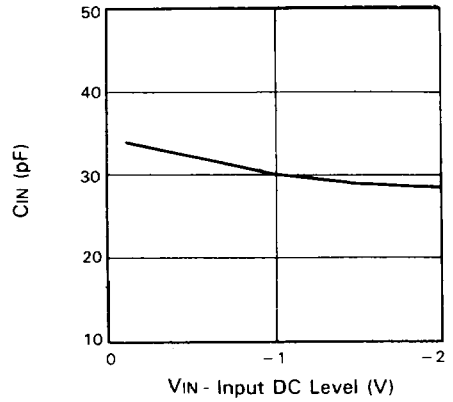

**ICC vs. Ambient temperature**

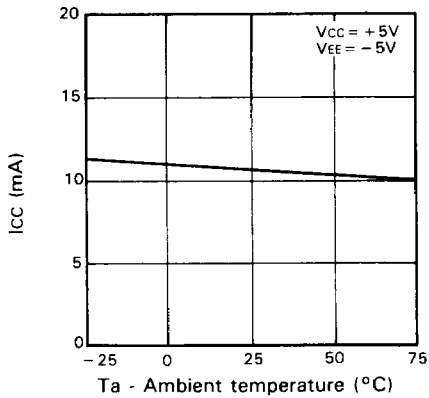

**IEE vs. Ambient temperature**

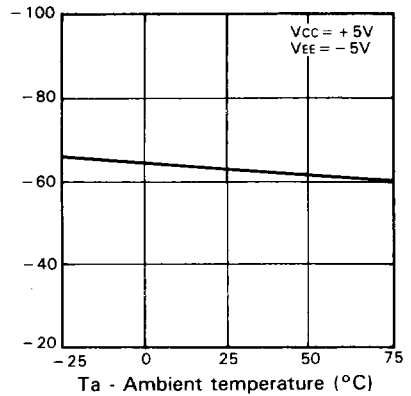

**TDLH, TDHL vs. Ambient temperature**

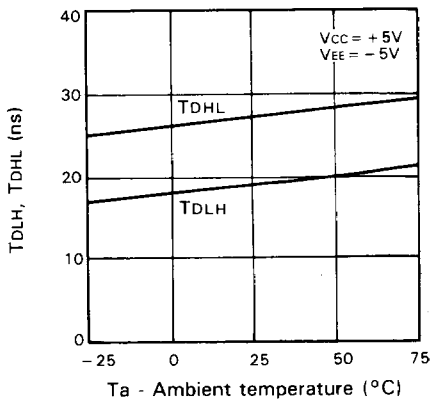

**tds vs. Ambient temperature**

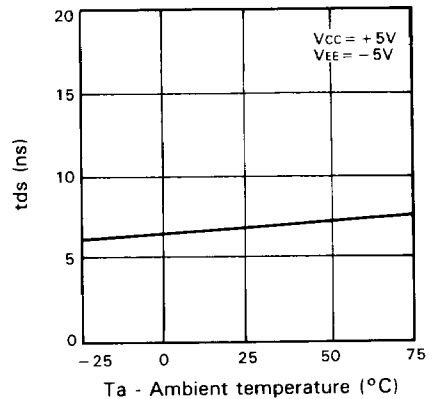

SNR vs.  $F_{IN}$

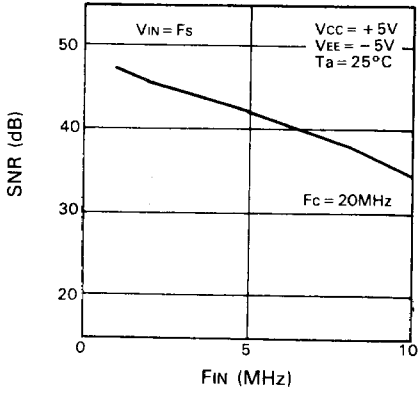

Effective bit vs.  $F_{IN}$

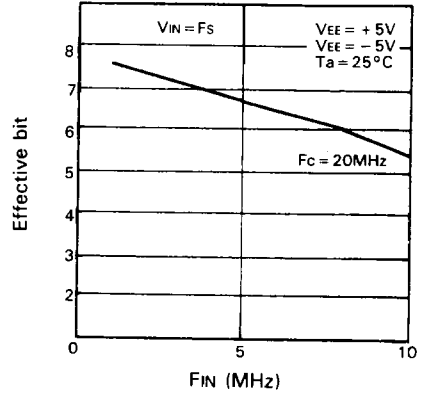

Package Outline Unit : mm

28pin SOP(Plastic) 375mil 0.6g

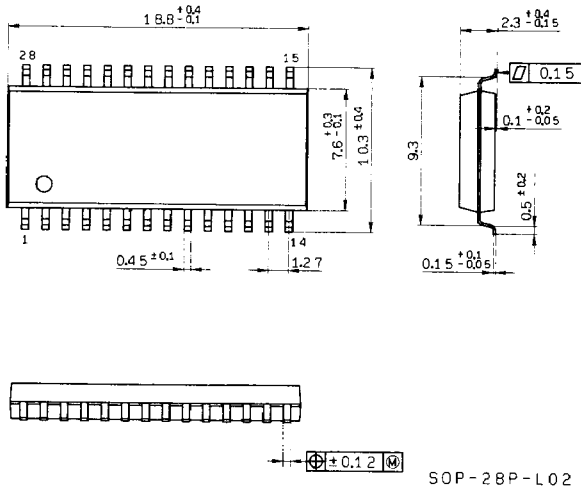

3

This datasheet has been downloaded from:

[www.DatasheetCatalog.com](http://www.DatasheetCatalog.com)

Datasheets for electronic components.



LittleDiode supplies new, hard to find or obsolete electronic components and semiconductors all over the world.

With over two million different components listed you are sure to find the part you need.

Feel free to visit us today at our online store:

**[LittleDiode.com](http://LittleDiode.com)**

Looking forward to providing you with the best possible service.