

TV Sound Processor

Description

The CXA1279AS is a bipolar IC for TV sound control with functions such as tone control, volume and balance.

Features

- 2 types of inputs
- Bass, Treble, Balance and Volume control operative in either 0 to Vcc or 0 to 5V.

Applications

TV

Structure

Bipolar silicon monolithic IC

Operating condition

- Operating supply voltage Vcc 8.5 to 12.5 V

Absolute Maximum Ratings

- Supply voltage Vcc 17 V
- Operating temperature Topr -20 to +75 °C
- Storage temperature Tstg -65 to +150 °C
- Allowable power dissipation Pd 900 mW

Block Diagram and Pin Configuration

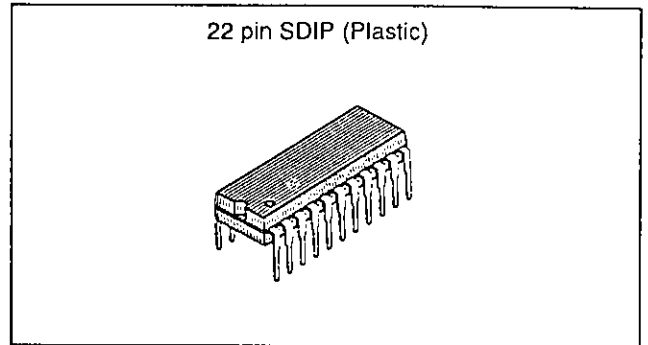
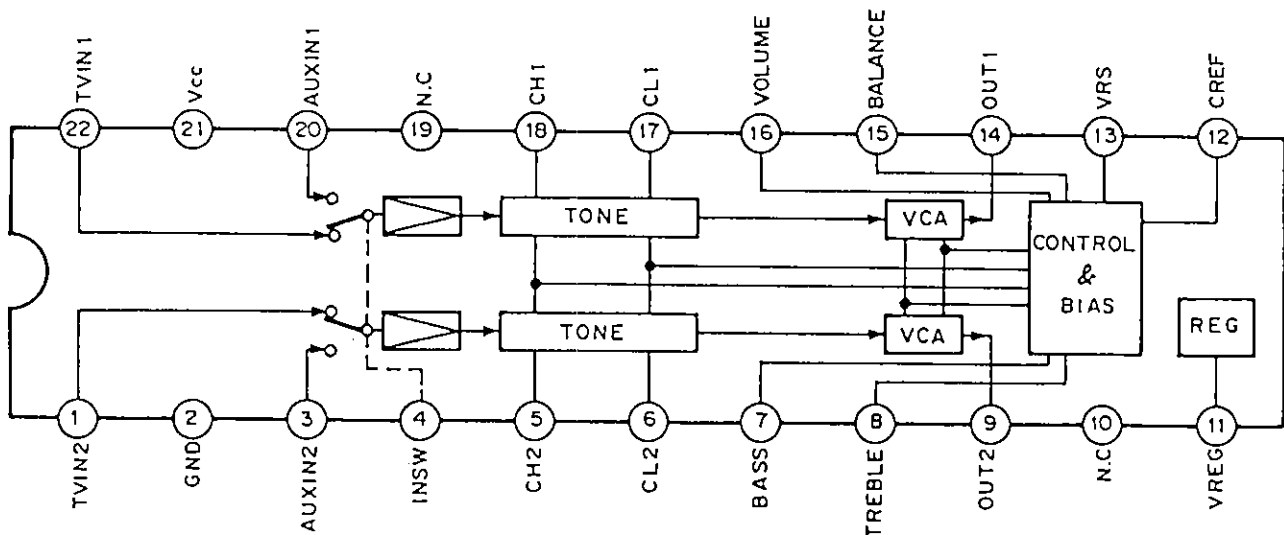

Sony reserves the right to change products and specifications without prior notice. This information does not convey any license by any implication or otherwise under any patents or other right. Application circuits shown, if any, are typical examples illustrating the operation of the devices. Sony cannot assume responsibility for any problems arising out of the use of these circuits.

Pin Description

(Ta=25°C Vcc=9V)

Pin No.	Symbol	Voltage	Equivalent circuit	Description
1	TV-IN2	4.5V		TV mode input pin.
3	AUX-IN2	4.5V		AUX mode input pin.
4	INSW			Mode select pin.
5	CH2	4.5V		External pin of HPF capacitor.

Pin No.	Symbol	Voltage	Equivalent circuit	Description
6	CL2	4.5V		External pin of LPF capacitor.
7	BASS	4.5V (CREF)		BASS control pin.
8	TREBLE	4.5V (CREF)		TREBLE control pin.
9	OUT2	4.5V		Output pin.

Pin No.	Symbol	Voltage	Equivalent circuit	Description
11	VREG	2.5V		REGULATOR output pin.
12	CREF			Input pin of control reference voltage.
13	VRS	4.5V		Reference voltage pin. Voltage $V_{cc}/2$.
14	OUT1	4.5V		Output pin.

Pin No.	Symbol	Voltage	Equivalent circuit	Description
15	BALANCE	4.5V (CREF)		BALANCE control pin.
16	VOLUME			VOLUME control pin.
17	CL1	4.5V		External pin of LPF capacitor.
18	CH1	4.5V		External pin of HPF capacitor.

Pin No.	Symbol	Voltage	Equivalent circuit	Description
20	AUX-IN1	4.5V		AUX mode input pin.
22	TV-IN1	4.5V		TV mode input pin.

Electrical Characteristics

(Ta=25°C)

No.	Item	Symbol	Bias conditions (V)						CREF	Input	Input signal	Output	Remarks	Min.	Typ.	Max.	Unit
			INSW	BASS	TRE	BAL	VOL	Vcc									
1	Current consumption 1	Icc-9	0	4.5	4.5	4.5	9.0	9.0	VRS				18	28	36	mA	
2	Current consumption 2	Icc-12		6.0	6.0	6.0	12.0	12.0					25	35	45	mA	
3	TV Gain 1, 2	VTVF 1, 2		4.5	4.5	4.5	9.0	9.0		TV-IN 1, 2	1kHz 1.8 Vrms	OUT 1, 2	Input is taken as reference.	-3.0	-1.0	+1.0	dB
4	AUX Gain 1, 2	VAUXF 1, 2	3.0							AUX-IN 1, 2				-3.0	-1.0	+1.0	dB
5	TV REF level 1, 2	VTVREF 1, 2	0				4.5			TV-IN 1, 2				-17	-14	-11	dB
6	FLAT f response characteristics 100Hz	VTVFL 1, 2									100Hz 1.8 Vrms		Output of respective channel 1kHz is taken as reference.	-1.5	0	+1.5	dB
7	FLAT f response characteristics 10kHz	VTVFH 1, 2									10kHz 1.8 Vrms			-1.5	0	+1.5	dB
8	GAIN VOL MIN 1, 2	VVOL MIN					0				1kHz 1.8 Vrms		Input is taken as reference.			-70	dB
9	BASS BOOST 100Hz 1, 2	VBST L		9.0	9.0		4.5				100Hz 1.8 Vrms		Output of respective channel FLAT 1kHz is taken as reference.	7.0	9.5	12.0	dB
10	TREBLE BOOST 10kHz 1, 2	VBST H									10kHz 1.8 Vrms			7.5	10	12.5	dB
11	BASS CUT 100Hz 1, 2	VCUT L		0	0						100Hz 1.8 Vrms			-12.0	-10	-7.0	dB
12	TREBLE CUT 10kHz 1, 2	VCUT H									10kHz 1.8 Vrms			-12.5	-10	-7.5	dB
13	BALANCE BOOST 1kHz 1	VBAL BST 1		4.5	4.5	9.0				TV-IN 1	1kHz 1.8 Vrms	OUT 1	Output of FLAT 1kHz is taken as reference.	0	1.0	2.0	dB
14	BALANCE CUT 1kHz 1	VBAL CUT 1				0										-30	dB
15	BALANCE BOOST 1kHz 2	VBAL BST 2								TV-IN 2		OUT 2		0	1.0	2.0	dB

No.	Item	Symbol	Bias conditions (V)							CREF	Input	Input signal	Output	Remarks	Min.	Typ.	Max.	Unit
			INSW	BASS	TRE	BAL	VOL	Vcc										
16	BALANCE CUT 1kHz 2	VBAL CUT 2	0	4.5	4.5	9.0	9.0	9.0	VRS	TV-IN 1, 2	1kHz 1.8 Vrms	OUT 2	Output of FLAT 1kHz is taken as reference.	—	—	-30	dB	
17	DISTORTION-1 1kHz 1, 2	Vdist F				4.5					1kHz 420 mVrms	OUT 1, 2		—	—	1.0	%	
18	DISTORTION-2 1kHz 1, 2	Vdist F MAX									1kHz 1.8 Vrms			—	—	2.0	%	
19	Cross-Talk TV → AUX	CTLK TA	3.0											—	—	-70	dB	
20	Cross-Talk AUX → TV	CTLK AT	0							AUX-IN 1, 2				—	—	-70	dB	
21	Cross Talk TV1 → TV2	CTLK TT1								TV-IN 1		OUT 2		—	—	-70	dB	
22	Cross-Talk TV2 → TV1	CTLK TT2								TV-IN 2		OUT 1		—	—	-70	dB	
23	Cross-Talk AUX1 → AUX2	CTLK AA1	3.0							AUX-IN 1		OUT 2		—	—	-70	dB	
24	Cross-Talk AUX2 → AUX1	CTLK AA2								AUX-IN 2		OUT 1		—	—	-70	dB	
25	REGULATOR DC OUTPUT	VREG	0									Pin 11 DC		2.2	2.5	2.8	Vdc	
26	NOISE LEVEL 1, 2	NL										OUT 1, 2	30kHz LPF used.	—	—	-60	dBm	
27	DC OFFset 1	VOFFset 1		4.5 ↓ 0										-1.0	0	1.0	Vdc	
28	DC OFFset 2	VOFFset 2		4.5 ↓ 9.0										-1.0	0	1.0	Vdc	
29	DC OFFset 3	VOFFset 3		4.5	4.5 ↓ 0									-1.0	0	1.0	Vdc	
30	DC OFFset 4	VOFFset 4			4.5 ↓ 9.0									-1.0	0	1.0	Vdc	

Electrical Characteristics Circuit

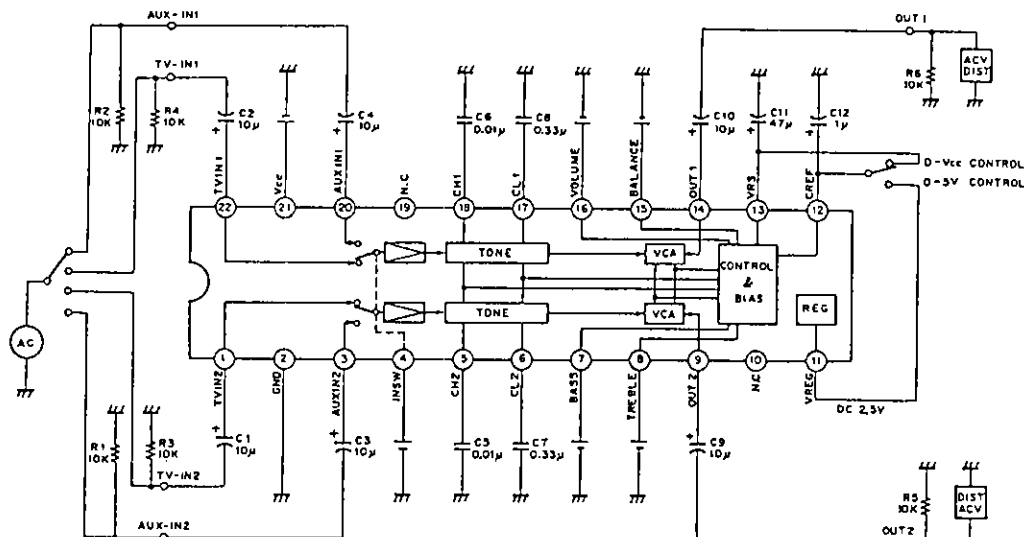

Application Circuit

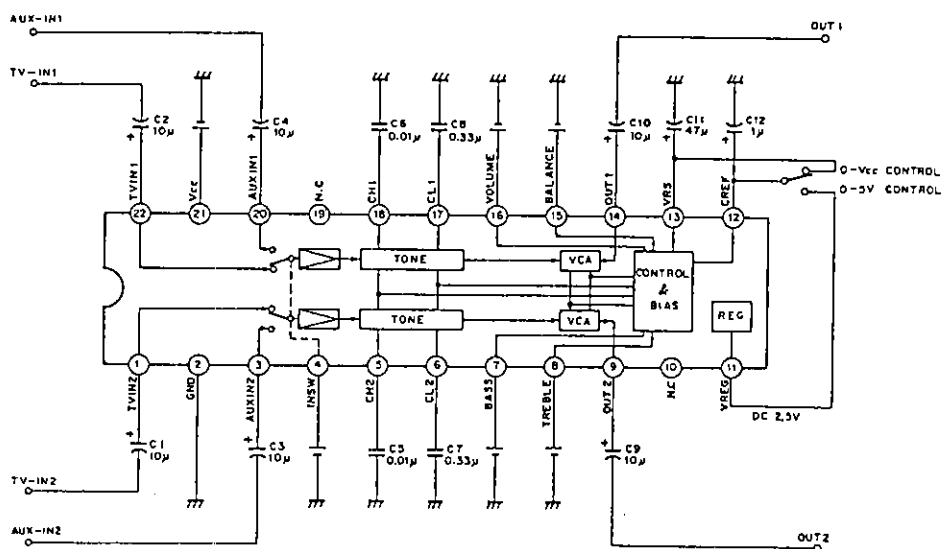

Application circuits shown are typical examples illustrating the operation of the devices. Sony cannot assume responsibility for any problems arising out of the use of these circuits or for any infringement of third party patent and other right due to same.

Description of Operation

Signals input to TV-IN and AUX-IN are switched through INSW (Input Switch) and input to Tone Control circuit.

In the Tone Control circuit, Tone Control for Bass and Treble is executed at the cut off frequency determined by the respective external capacitor.

Tone controlled signals are Balance and Volume controlled at the VCA circuit and output through the output buffer.

The control of Bass, Treble, Balance and Volume respectively is performed with CREF pin voltage as reference. Accordingly when control is used from 0 to Vcc, Vcc/2 is applied to CREF (connected to VRS pin). To control from 0 to 5Vdc, 2.5Vdc is applied to CREF for usage (connected to VREG pin or half the voltage of 5V supply microcomputer is applied for offset.).

TONE characteristics

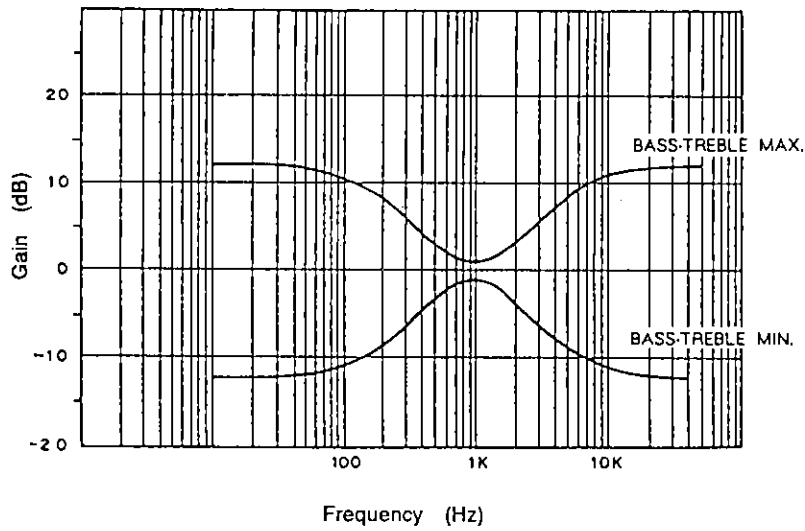

CH. vs. TREBLE-CONTROL (MAX)

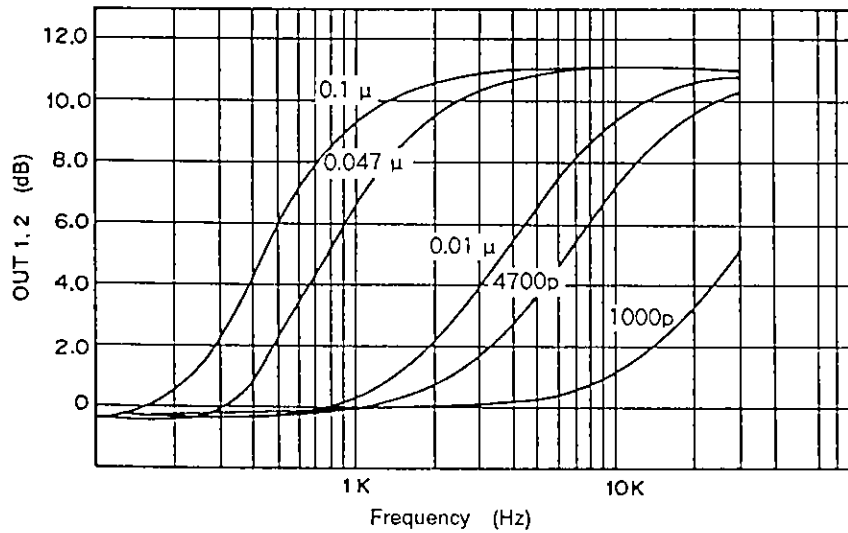

CL. vs. BASS-CONTROL (MAX)

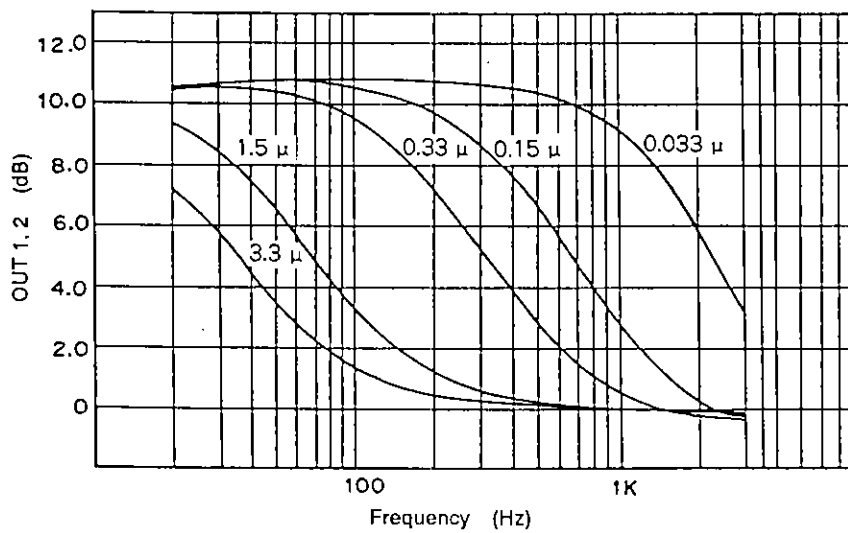

VOLUME CONTROL characteristics

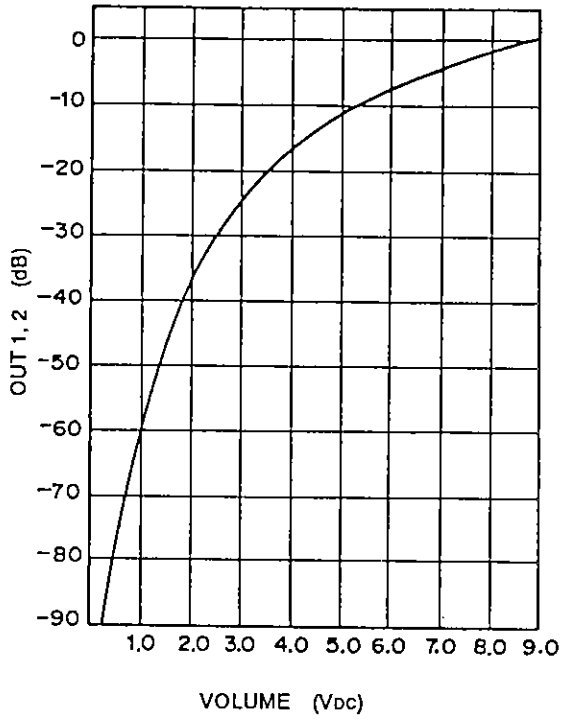

BALANCE CONTROL characteristics

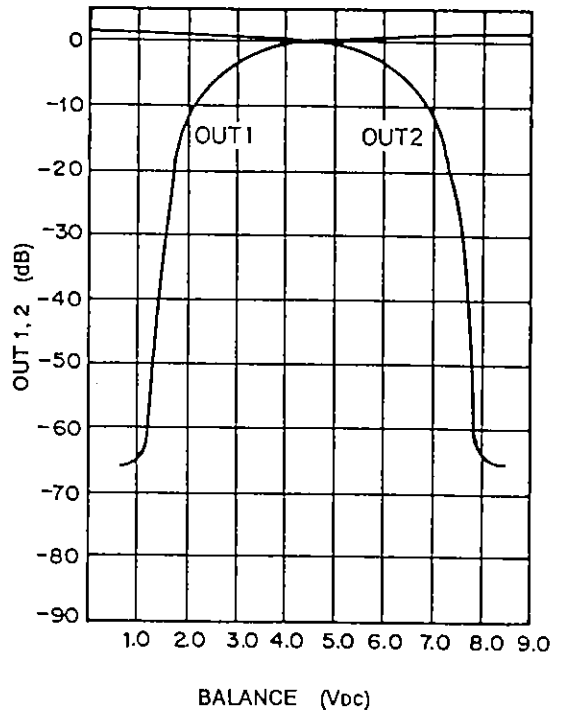

BASS CONTROL characteristics

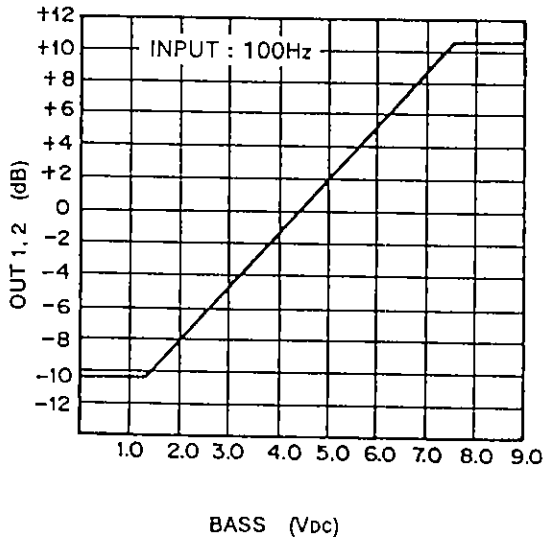

TREBLE CONTROL characteristics

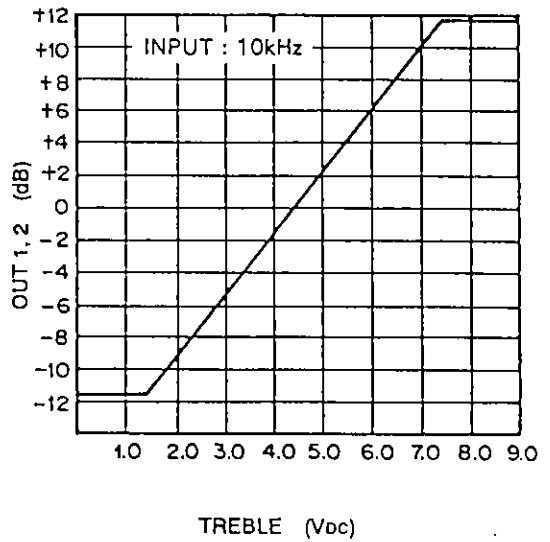

Package Outline Unit : mm

22pin SDIP (Plastic) 300mil

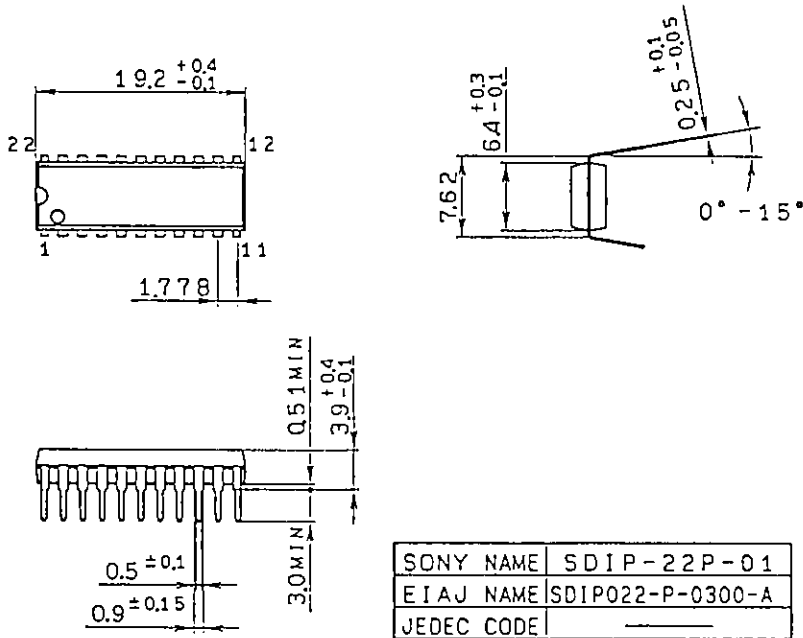



LittleDiode supplies new, hard to find or obsolete electronic components and semiconductors all over the world.

With over two million different components listed you are sure to find the part you need.

Feel free to visit us today at our online store:

LittleDiode.com

Looking forward to providing you with the best possible service.