

EIAJ Sound Multiplexing Decoder

Description

The CXA1518Q/S are bipolar ICs designed for EIAJ TV sound multiplexing decoders. These ICs provide various functions including sound multiplexing demodulation, broadcast mode discrimination (stereo/bilingual discrimination display), mode display, and muting.

Features

- External parts greatly reduced with a built-in active filter.
- Count down can be used for broadcast mode discrimination so that adjustment for discrimination system (Q-OSC) is not required.
- Output level of 380 mVrms (1 kHz, MONO, 100 %)
- Forced monaural operates with both stereo and bilingual broadcasts.
- Built-in digital facsimile interference elimination filter.
- Low supply voltage ($V_{CC}=5\text{ V}$)
- The pin configuration of the CXA1518S is identical to that of the CXA1138AS.

Applications

- Color TVs
- Hi-Fi VCRs
- Liquid crystal TVs

Structure

Bipolar silicon monolithic IC

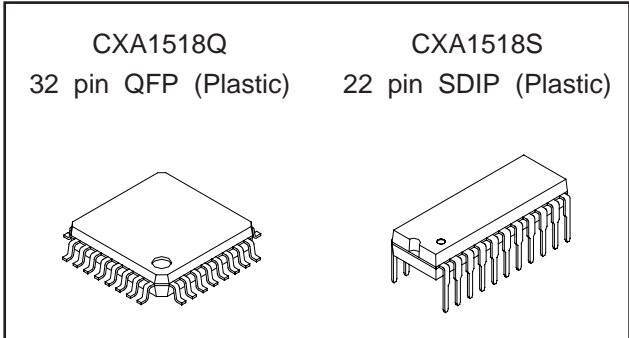

Absolute Maximum Ratings ($T_a=25\text{ }^\circ\text{C}$)

[Pin numbers shown are for the CXA1518S.]

- | | | | |
|--|-----------|-------------|------------------|
| • Supply voltage | V_{CC} | 10 | V |
| • Input signal
(Pin 6) | V_{IS} | 0.6 | Vp-p |
| • Control voltage
(Pins 12, 13, 14) | V_{IC} | V_{CC} | V |
| • Operating temperature | T_{OPR} | -20 to +75 | $^\circ\text{C}$ |
| • Storage temperature | T_{STG} | -65 to +150 | $^\circ\text{C}$ |
| • Allowable power dissipation | P_D | 900 | mW |
| | | | (SDIP) |
| | | 470 | mW |
| | | | (QFP) |
| • LED drive current | I_{LED} | 10 | mA |

Operating Voltage

6.0 to 4.5 V

Sony reserves the right to change products and specifications without prior notice. This information does not convey any license by any implication or otherwise under any patents or other right. Application circuits shown, if any, are typical examples illustrating the operation of the devices. Sony cannot assume responsibility for any problems arising out of the use of these circuits.

Block Diagram

CXA1518Q

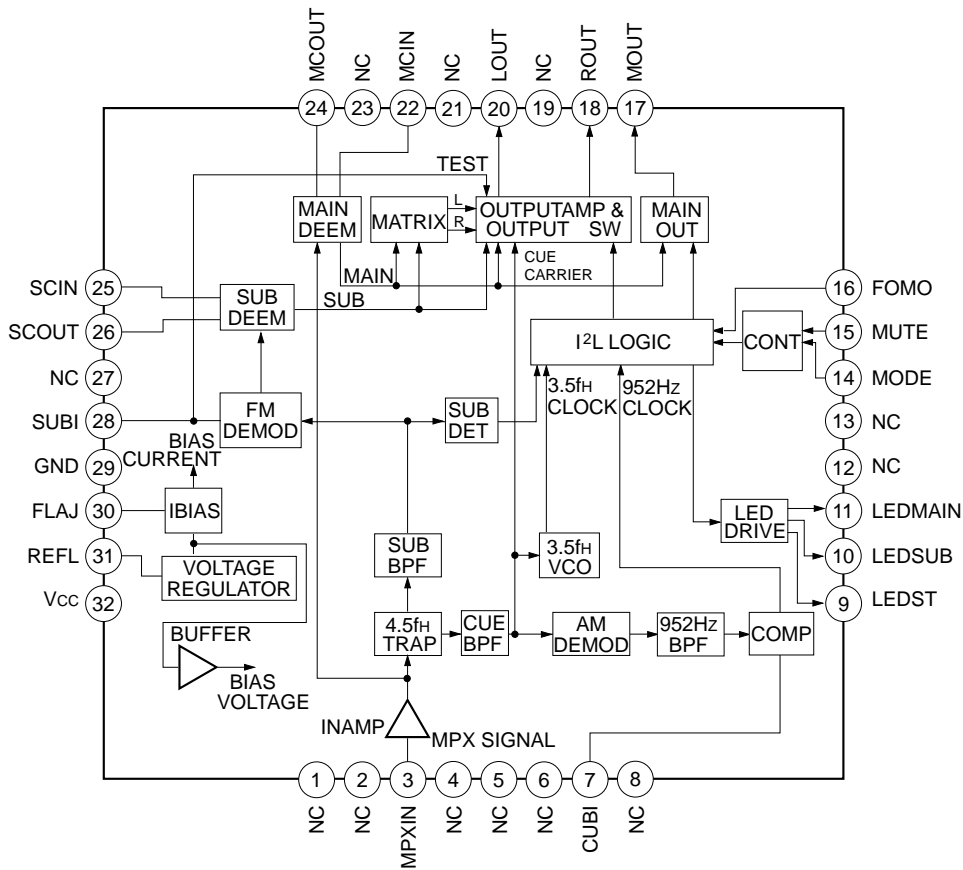

CXA1518S

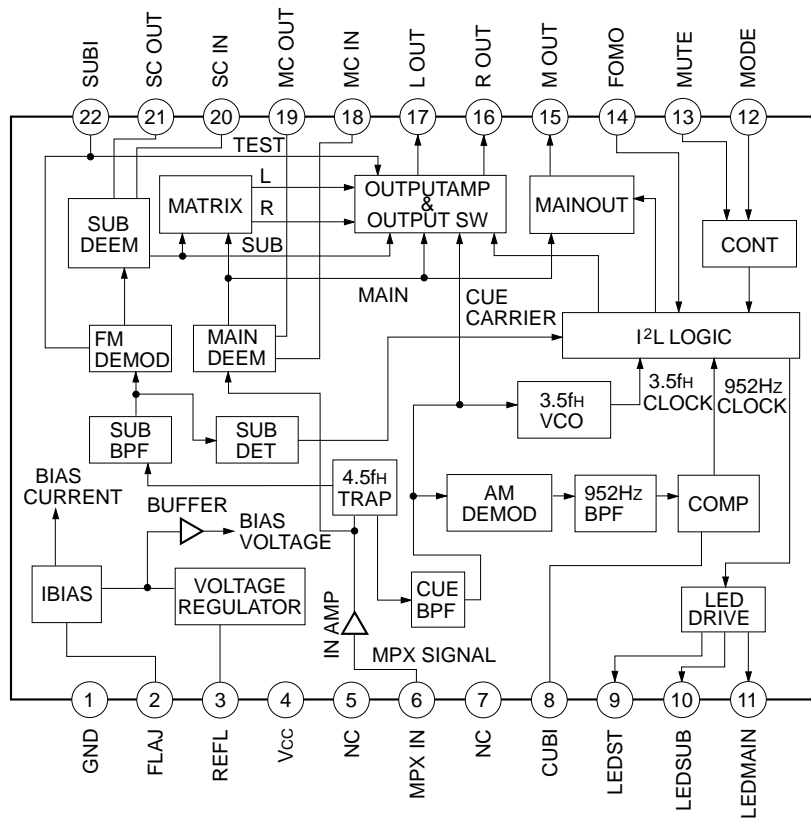

Pin Description (Ta=25 °C, Vcc=5 V)

Pin numbers in brackets are for the CXA1518Q.

Pin No.		Symbol	Pin voltage	Equivalent circuit	Description
SDIP	QFP				
1	29	GND	0		GND
2	30	FLAJ	2.4 V		Filter adjustment pin
3	31	REFL	2.5 V		Connects noise elimination filter of internal reference power supply.
4	32	Vcc	—		Power supply pin
6	3	MPXIN	2.5 V		Sound multiplexing signal input. Standard input level=70 mVrms (MONO 100 %)
8	7	CUBI	2.4 V		Connects bias capacitor for Cue pulse generator.

Pin No.		Symbol	Pin voltage	Equivalent circuit	Description
SDIP	QFP				
9	9	LEDST	—		<p>Connects the LEDs to display each mode.</p> <p>Pin 9: Stereo</p> <p>Pin 10: Sub</p> <p>Pin 11: Main</p>
10	10	LEDSU			
11	11	LEDM			
12	14	MODE	—		<p>Switches the output mode with the DC voltage during bilingual broadcasting.</p>
13	15	MUTE	—		<p>Output mute pin.</p> <p>When set to high, only DC is output from Pins 15, 16 and 17 (Pins 17, 18 and 20).</p>
14	16	FOMO	—		<p>Forced monaural pin.</p> <p>When set to high, monaural function (main) is forcibly set regardless of stereo and bilingual broadcasts and LEDs are extinguished.</p>
15	17	MOUT	2.4 V		<p>Main signal output pin.</p> <p>Always outputs the main signal component regardless of the broadcast mode.</p>

Pin No.		Symbol	Pin voltage	Equivalent circuit	Description
SDIP	QFP				
16	18	ROUT	2.4 V		R-ch output pin
17	20	LOUT	2.4 V		L-ch output pin. During "TEST", outputs the Cue signal component passed through the Cue BPF.
18	22	MCIN	2.5 V		Connects DC cut capacitor of the main signal.
19	24	MCOUT	1.7 V		
20	25	SCIN	2.5 V		Connects DC cut capacitor of the sub signal.
21	26	SCOUT	1.7 V		
22	28	SUBI	2.4 V		Connects bias capacitor of the sub FM detector. Grounding this pin enables the TEST mode for filter adjustment.

Pin No.		Symbol	Pin voltage	Equivalent circuit	Description
SDIP	QFP				
5, 7	1, 2 4, 5 6, 8 12, 13 19, 21 23, 27	NC	—	—	Keep these pins open (They are not connected to the chip.)

Electrical Characteristics Measurement Circuit (CXA1518S)

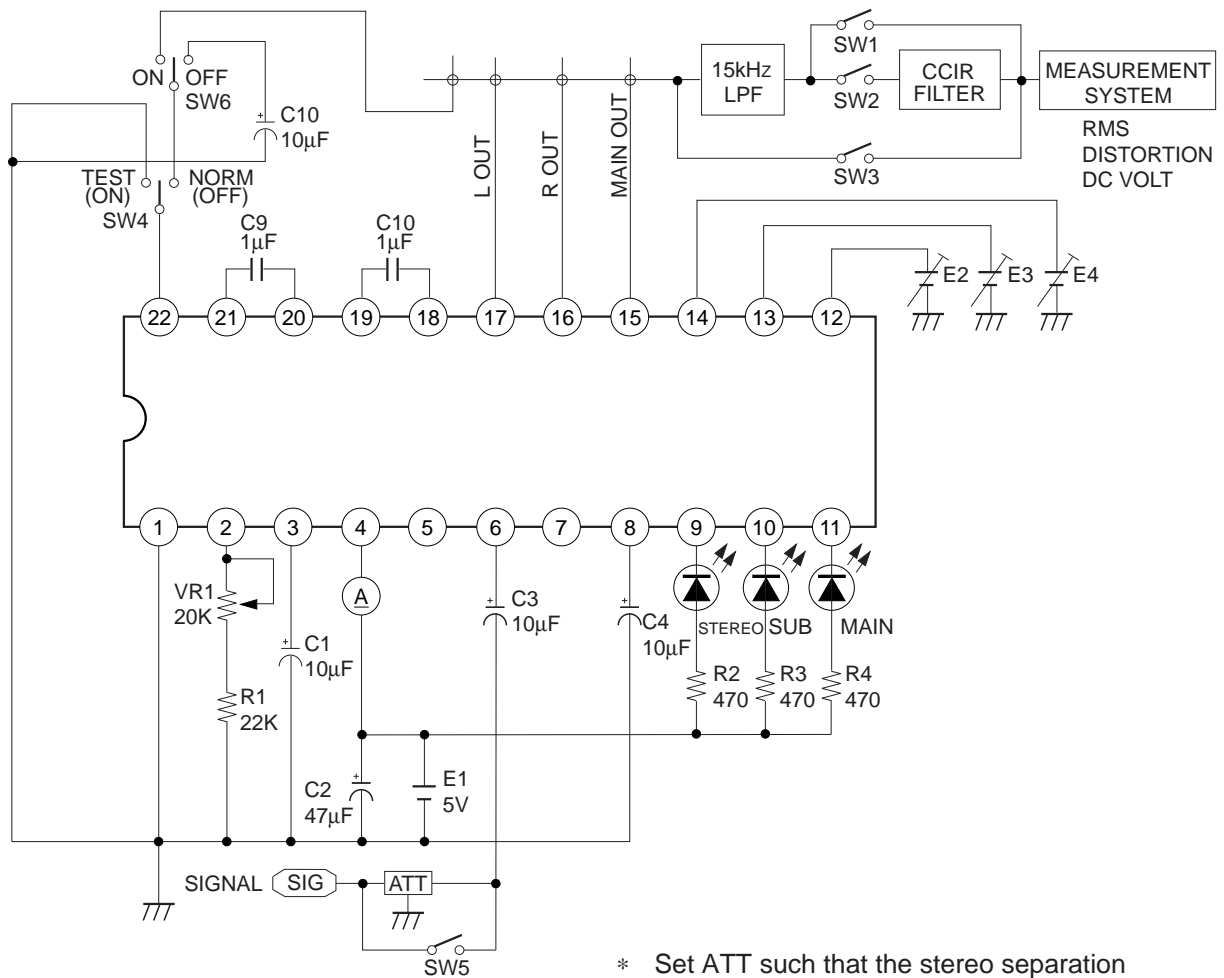

Electrical Characteristics (Ta=25 °C, Vcc=5 V) Pin numbers shown in conditions are for the CXA1518S.

No.	Item	Symbol	SW conditions	Bias conditions	Conditions	Test point		Min.	Typ.	Max.	Unit
						SDIP	QFP				
1	Current consumption	Icc	1	1	Measures the input current to Pin 4.	Pin 4	Pin 32	14	20	26	mA
2	Sub output level 400 Hz	VS1	4	2 and 3	Input signal: SIG1 Measures output amplitude at Pins 16 and 17 (400 Hz, sine wave) : Vs1 (15 k LPF)	Pins 16 and 17 *1	Pins 18 and 20	330	380	480	mVrms
3	Sub frequency response characteristics 1 kHz	FS1	4	2 and 3	Input signal: SIG2 Measures output amplitude at Pins 16 and 17 (1kHz, sine wave) : Vs2 $Fs1=20 \log \frac{Vs2}{Vs1}$ (15 k LPF)	Pins 16 and 17 *1	Pins 18 and 20	-1.6	-0.6	0	dB
4	Sub frequency response characteristics 10 kHz	FS2	4	2 and 3	Input signal: SIG3 Measures output amplitude at Pins 16 and 17 (10 kHz, sine wave) : Vs3 $Fs2=20 \log \frac{Vs3}{Vs1}$ (15 k LPF)	Pins 16 and 17 *1	Pins 18 and 20	-19.0	-17.0	-14.7	dB
5	Sub distortion factor	DS	4	2 and 3	Input signal: SIG2 Measures output signal distortion factor at Pins 16 and 17 (1 kHz, sine wave). (15 k LPF)	Pins 16 and 17 *1	Pins 18 and 20	—	1	2	%
6	Sub S/N	NS	4	2 and 3	Input signal: SIG2 Measures S/N ratio of the outputs (1 kHz) at Pins 16 and 17. (15 k LPF. RMS)	Pins 16 and 17 *1	Pins 18 and 20	58	62	—	dB
7	Stereo distortion factor L ch	Dst1	4	2	Input signal: SIG4 Measures output signal distortion factor at Pin 17 (1 kHz, sine wave). (15 k LPF)	Pin 17	Pin 20	—	0.2	1.5	%
8	Stereo distortion factor R ch	Dstr	4	2	Input signal: SIG5 Measures output signal distortion factor at Pin 16 (1 kHz, sine wave) (15 k LPF)	Pin 16	Pin 18	—	0.2	1.5	%
9	Stereo output level L ch 1 kHz	Vst1	4	2	Input signal: SIG4 Measures output amplitude at Pin 17 (1 kHz, sine wave). (15 k LPF)	Pin 17	Pin 20	310	360	440	mVrms

*1 When bias condition is [3], the test point is Pin 16 only.

No.	Item	Symbol	SW conditions	Bias conditions	Conditions	Test point		Min.	Typ.	Max.	Unit
						SDIP	QFP				
10	Stereo output level R ch 1 kHz	Vstr	4	2	Input signal: SIG5 Measures output amplitude at Pin 16 (1 kHz, sine wave). (15 k LPF)	Pin 16	Pin 18	310	360	440	mVrms
11	Main output level MAIN OUT	Vm1	4	2	Input signal: SIG6 Measures output signal at Pin 15 (400 Hz, sine wave). (15 k LPF)	Pin 15	Pin 17	330	390	480	mVrms
12	Main output level	Vm2	4	2	Input signal: SIG6 Measures output signal amplitude at Pins 16 and 17 (400 Hz, sine wave). (15 k LPF)	Pins 16 and 17	Pins 18 and 20	330	390	480	mVrms
13	Main frequency response characteristics 1 kHz	Fm1	4	2	Input signal: SIG7 Measures output amplitude at Pins 16 and 17 (1kHz, sine wave) : Vm3 $Fm1=20 \log \frac{Vm3}{Vm2}$ (15 k LPF)	Pins 16 and 17	Pins 18 and 20	-1.6	-0.6	0	dB
14	Main frequency response characteristics 10 kHz	Fm2	4	2	Input signal: SIG8 Measures output amplitude at Pins 16 and 17 (10 kHz, sine wave): Vm4 $Fm2=20 \log \frac{Vm4}{Vm2}$ (15 k LPF)	Pin 15	Pin 17	-16.5	-14.5	-12.5	dB
15	Main distortion factor MAIN OUT	Dm1	4	2	Input signal: SIG7 Measures output signal distortion factor at Pin 15 (1 kHz, sine wave). (15 k LPF)	Pins 16 and 17	Pins 18 and 20	—	0.2	1	%
16	Main distortion factor	Dm2	4	2	Input signal: SIG7 Measures output signal distortion factor at Pins 16 and 17 (1 kHz, sine wave). (15 k LPF)	Pins 16 and 17	Pins 18 and 20	—	0.2	1	%
17	Main distortion factor at maximum input	Dm3	4	2	Input signal: SIG9 Measures output signal distortion factor at Pins 16 and 17 (1 kHz, sine wave). (15 k LPF)	Pins 16 and 17	Pins 18 and 20	—	0.3	3	%
18	Main S/N ratio	Nm	4	2	Input signal: SIG7 Measures S/N ratio of outputs at Pins 16 and 17 (1 kHz). (15 k LPF. RMS)	Pins 16 and 17	Pins 18 and 20	65	69	—	dB

No.	Item	Symbol	SW conditions	Bias conditions	Conditions	Test point		Min.	Typ.	Max.	Unit
						SDIP	QFP				
19	Stereo separation L → R	Sstr	4	2	Input signal: SIG4 Sstr= $20 \log \frac{\text{Pin17 output amplitude}}{\text{Pin 16 output amplitude}} \text{ (dB)}$ (15 k LPF)	Pins 16 and 17	Pins 18 and 20	35	50	—	dB
20	Stereo separation R → L	Sstl	4	2	Input signal: SIG5 Sstl= $20 \log \frac{\text{Pin16 output amplitude}}{\text{Pin17 output amplitude}} \text{ (dB)}$ (15 k LPF)	Pins 16 and 17	Pins 18 and 20	35	50	—	dB
21	Cross talk Main → Sub	Cms1	2	2	Input signal: SIG15 Calculates the level difference between the output amplitude at Pins 16 and 17 (Vms1) and the measured value in measurement No. 13 (Vm3). $\text{Cms1} = 20 \log \frac{V_{m3}}{V_{ms1}} \text{ (dB)}$ (15 k LPF, 1 k BPF)	Pins 16 and 17	Pins 18 and 20	52	59	—	dB
22	Cross talk Sub → Main	Csm1	2	1	Input signal: SIG2 Calculates the level difference between the output amplitude at Pins 16 and 17 (Vsm1) and the measured value in measurement No. 3 (Vs2). $\text{Csm1} = 20 \log \frac{V_{s2}}{V_{sm1}} \text{ (dB)}$ (15 k LPF, 1 k BPF)	Pins 16 and 17	Pins 18 and 20	59	66	—	dB
23	Cross talk Main → Sub BOTH MODE	Cms2	2	3	Input signal: SIG15 Calculates the level difference between the output amplitudes at Pin 16 (Vms2) and at Pin 17 (Vms3) $\text{Cms2} = 20 \log \frac{V_{ms3}}{V_{ms2}} \text{ (dB)}$ (15 k LPF, 1 k BPF)	Pins 16 and 17	Pins 18 and 20	52	58	—	dB

No.	Item	Symbol	SW conditions	Bias conditions	Conditions	Test point		Min.	Typ.	Max.	Unit
						SDIP	QFP				
24	Cross talk Sub → Main BOTH MODE	Csm2	2	3	Input signal: SIG2 Calculates the level difference between the output amplitude at Pin 17 (Vsm2) and at Pin 16 (Vsm3). $Csm2=20 \log \frac{Vsm3}{Vsm2} \text{ (dB)}$ (15 k LPF, 1 k BPF)	Pins 16 and 17	Pins 18 and 20	59	64	—	dB
25	Residual carrier Sub	Lcs	3	2	Input signal: SIG11 Measures the amplitude of the subcarrier component of the output at Pins 16 and 17.	Pins 16 and 17	Pins 18 and 20	—	14	30	mVrms
26	Residual carrier Main	Lcm	3	1	Input signal: SIG11 Measures the amplitude of the subcarrier component of the output at Pins 16 and 17.	Pins 16 and 17	Pins 18 and 20	—	10	20	mVrms
27	Mute volume Main	Mm	2	4	Input signal: SIG7 Calculate the level difference between the output amplitude at Pins 16 and 17 (VMm) and the measured value in measurement No. 13 (Vm3). $Mm=20 \log \frac{Vm3}{VMm} \text{ (dB)}$ (1 k BPF, 15 k LPF)	Pins 16 and 17	Pins 18 and 20	70	80	—	dB
28	Mute volume Sub	Ms	2	4	Input signal: SIG2 Calculates the level difference between the output amplitude at Pins 16 and 17 (VMs) and the measured value in measurement No. 3 (Vs2). $Ms=20 \log \frac{Vs2}{VMs} \text{ (dB)}$ (1 k BPF, 15 k LPF)	Pins 16 and 17	Pins 18 and 20	70	80	—	dB
29	Mute volume Stereo	Mst	2	2 and 4	Input signal: SIG4 and 5 Measures output signal level difference at Pins 16 and 17 under bias conditions 2 and 4. Mst= $20 \log \frac{\text{measured value under bias condition 2 (mVrms)}}{\text{measured value under bias condition 4 (mVrms)}}$ (1 k BPF, 15 k LPF)	Pins 16 and 17 *2	Pins 18 and 20	70	80	—	dB

*2 Measure Pin 17 when input signal is SIG4, and Pin 16 when input signal is SIG5.

No.	Item	Symbol	SW conditions	Bias conditions	Conditions	Test point		Min.	Typ.	Max.	Unit
						SDIP	QFP				
30	DC offset Stereo L ch	Ostl	3	2 and 4	Input signal: SIG18 Measures output DC level fluctuation at Pin 17 under bias conditions 2 and 4.	Pin 17	Pin 20	—	20	100	mV
31	DC offset Stereo R ch	Ostr	3	2 and 4	Input signal: SIG18 Measures output DC level fluctuation at Pin 16 under bias conditions 2 and 4.	Pin 16	Pin 18	—	20	100	mV
32	DC offset Main out	Om	3	2 and 4	Input signal: No input Measures output DC level fluctuation at Pin 15 under bias conditions 2 and 4.	Pin 15	Pin 17	—	20	100	mV
33	Cue detector sensitivity	CD	4	2	Input signal: SIG12 Varying SIG12, measures attenuation while switching from monaural to sound multiplexing mode.	—	—	8	11	17	dB
34	Sub detector sensitivity	SD	4	2	Input signal: SIG13 Varying SIG13, measures attenuation while switching from monaural to sound multiplexing mode.	—	—	9	12	17	dB
35	Cue BPF gain	CG	5	2	Input signal: SIG14 Measures output amplitude at Pin 17	Pin 17	Pin 20	125	190	290	mVrms
36	4.5 fH trap attenuation level	TG	6	2	Input signal: SIG16 and SIG17 Measuring output amplitude at Pin 22, measure the output signal level difference when inputting SIG16 and when inputting SIG17. TG= $20 \log \frac{\text{measured value for SIG16 (mVrms)}}{\text{measured value for SIG17 (mVrms)}}$	Pin 22	Pin 28	20	35	—	dB

SW Condition Table

No. \ SW	1	2	3	4	5	6
1	off	off	off	off	off	off
2	off	on	off	off	off	off
3	off	off	on	off	off	off
4	on	off	off	off	off	off
5	off	off	on	on	on	off
6	off	off	on	off	on	on

BIAS Condition Table

No. \ SW	E1	E2	E3	E4
1	5 V	0.5 V	0.5 V	0.5 V
2	5 V	4.5 V	0.5 V	0.5 V
3	5 V	2.5 V	0.5 V	0.5 V
4	5 V	4.5 V	4.5 V	0.5 V

Input Signal Definitions

SIG1 : Sound MPX signal Main : 0 % Sub : 400 Hz, 100 % MOD Cue : Bilingual	SIG10 : Sound MPX signal L ch : 1 kHz, 100 % R ch : 0 % Cue : Cue signal OFF
SIG2 : Sound MPX signal Main : 0 % Sub : 1 kHz, 100 % MOD Cue : Bilingual	SIG11 : Sound MPX signal Main : 0 % Sub : 0 % (carrier only) Cue : Bilingual
SIG3 : Sound MPX signal Main : 0 % Sub : 10 kHz, 100 % MOD Cue : Bilingual	SIG12 : Sound MPX signal Main : 0 % Sub : 0 % (carrier only) Cue : Bilingual (Level adjusted to the minimum)
SIG4 : Sound MPX signal L ch : 1 kHz, 100 % R ch : 0 % Cue : Stereo	SIG13 : Sound MPX signal Main : 0 % Sub : 0 % (level adjusted to the minimum) Cue : Bilingual
SIG5 : Sound MPX signal L ch : 0 % R ch : 1 kHz, 100 % Cue : Stereo	SIG14 : 55.069 kHz sine wave 5.6 mVrms
SIG6 : Sound MPX signal Main : 400 Hz, 100 % Sub : Carrier OFF Cue : Cue signal OFF	SIG15 : Sound MPX signal Main : 1 kHz, 100 % Sub : 0 % (carrier only) Cue : Bilingual
SIG7 : Sound MPX signal Main : 1 kHz, 100 % Sub : Carrier OFF Cue : Cue signal OFF	SIG16 : 31.47 kHz sine wave 42 mVrms
SIG8 : Sound MPX signal Main : 10 kHz, 100 % Sub : Carrier OFF Cue : Cue signal OFF	SIG17 : 70.80 kHz sine wave 42 mVrms
SIG9 : Sound MPX signal Main : 1 kHz, 250 % Sub : Carrier OFF Cue : Cue signal OFF	SIG18 : Sound MPX signal L ch : 0 % R ch : 0 % Cue : Stereo
	* Sound MPX signal level is defined as monaural 100 % at 1 Vp-p.

Output and LED ON/OFF Table

Broadcast status	MODE SW			Forced monaural	MUTE	Output status			LED ON/OFF conditions		
	SUB	BOTH	MAIN			L	R	MAIN	STEREO	SUB	MAIN
Stereo	×	×	×	off	off	L	R	L+R	on	off	off
	×	×	×	on	off	L+R	L+R	L+R	off	off	off
	×	×	×	×	on	DC	DC	DC	off	off	off
Bilingual	on			off	off	SUB	SUB	MAIN	off	on	off
		on		off	off	MAIN	SUB	MAIN	off	on	on
			on	off	off	MAIN	MAIN	MAIN	off	off	on
				on	off	MAIN	MAIN	MAIN	off	off	off
	×	×	×	×	on	DC	DC	DC	off	off	off
Monaural	×	×	×	×	off	MONO	MONO	MONO	off	off	off
	×	×	×	×	on	DC	DC	DC	off	off	off

× : No response

Control Voltage Range Pin numbers in brackets are for the CXA1518Q.

MODE SW		Voltage range
Pin 12 (Pin 14)	SUB	4.0 V to Vcc
	BOTH	2 V to 3 V
	MAIN	0 V to 0.5 V
FORCED MONO Pin 14 (Pin 16)	on	3 V to Vcc
	off	0 V to 0.5 V (or OPEN)
MUTE Pin 13 (Pin 15)	on	3 V to Vcc
	off	0 V to 0.5 V (or OPEN)

Description of Operation Pin numbers in brackets are for the CXA1518Q.

The sound multiplexing signal input from Pin 6 (Pin 3) passes through IN AMP, and is added to the Cue BPF, SUB BPF and the MAIN de-emphasis circuits.

1 Discrimination system

The Cue BPF passes only the Cue signal component of the multiplexing signal. The AM demodulator detects the amplitude modulation of the Cue signal (AM wave) and generates a sine wave of either 922.5 Hz (for bilingual) or 982.5 Hz (for stereo sound).

COMP shapes the carrier-stripped Cue signal into a waveform, transforming it into pulses of either 922.5 Hz or 982.5 Hz, after which it is added to the LOGIC unit.

A 3.5f_H VCO generates a 3.5f_H pulse locked to the Cue signal carrier wave (3.5f_H), and sends it to the LOGIC unit.

The LOGIC unit performs broadcast mode discrimination using the countdown method. From this result, and the existence/absence of a SUB signal from the SUB Detector, MUTE ON/OFF from CONT, MODE Switch, and the FOMO ON/OFF commands, the logic unit generates an output switchover control signal to control the output statuses of OUTPUT SW and MAIN OUT.

2 Main system

MAIN DEEM applies de-emphasis on the MAIN signal component and removes the SUB and Cue components. After having passed through MAIN DEEM, the MAIN signal is added to MATRIX, OUTPUT AMP, and MAIN OUT.

3 Sub system

SUB BPF passes the SUB signal component of the multiplexed signal. A 4.5 μ H trap filter then removes the digital facsimile signal component.

FM demodulation frequency demodulates the Sub signal.

The SUB DEEM applies de-emphasis on the FM demodulated Sub signal and removes the carrier wave component.

After passing through SUB DEEM, the SUB signal is added to MATRIX and OUTPUT AMP.

4 Matrix and output system

When broadcasting in stereo, MATRIX generates L and R signals by adding and subtracting the MAIN signal from MAIN DEEM and the SUB signal from SUB DEEM.

OUTPUT AMP & OUTPUT SW switch the output signals as instructed by LOCIG. Note that MAIN OUT always outputs the MAIN signal component regardless of the broadcast mode.

Adjustment Methods

1. Preset before filter adjustment

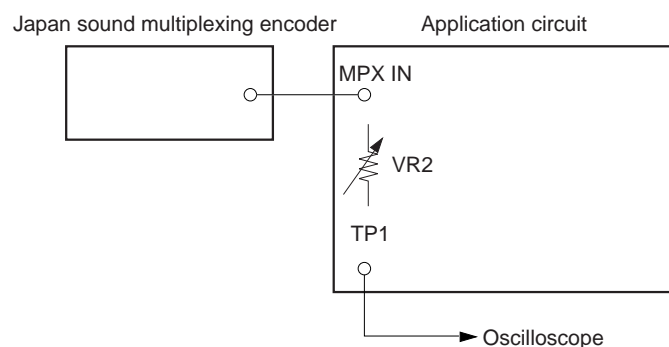

Fig. 1

Procedure

- 1) Connect as shown in Fig. 1
- 2) Set the encoder to MONO MODE, and input a 1 kHz signal to MPX IN.
- 3) Adjust VR2 until the level on TP1 (Pin 6) is 0.2 V_{p-p} (70 mV_{rms}).
(Pin 3 for the CXA1518Q)

2. Filter adjustment

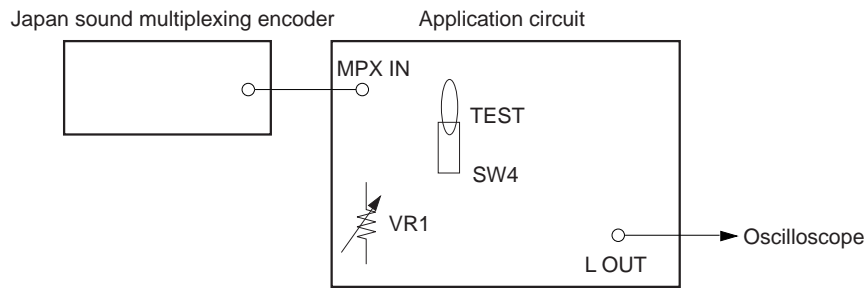

Fig. 2

Procedure

- 1) Connect as shown in Fig. 2.
- 2) Set SW4 to TEST. (Turn SW6 OFF)
- 3) Put the encoder in stereo mode, and input only a modulated Q signal into MPX IN of the board.
- 4) Observing L.OUT with the oscilloscope, adjust VR1 until the Q signal output to be maximum.

3 Separation adjustment

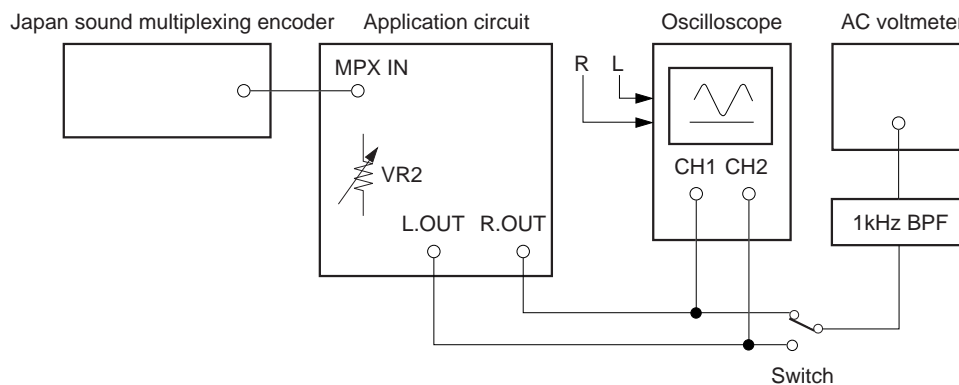
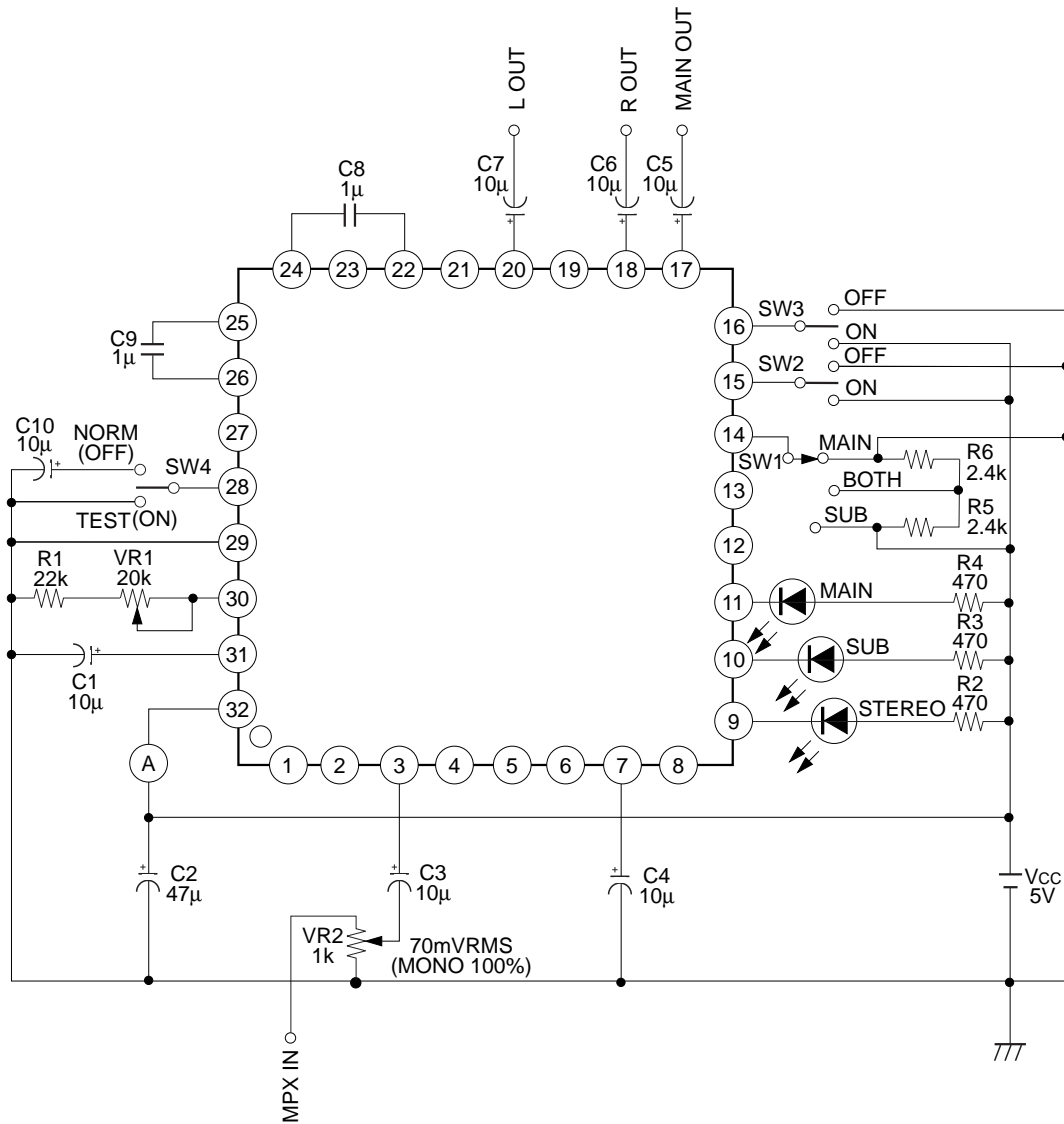

Fig. 3

Procedure

- 1) Connect as shown in Fig. 3. (Set SW4 to NORM)
- 2) • Set the encoder to stereo mode and perform 100 % modulation of a 1 kHz signal.
• Output only the L ch.
- 3) Observing the oscilloscope and the AC voltmeter, adjust VR2 until the R ch to be minimum. (Separation standard 35 dB or more)

Application Circuit
CXA1518Q



- * Non-polar capacitor is recommended for C8 and C9.
- * NC pin is left open.

Application circuits shown are typical examples illustrating the operation of the devices. Sony cannot assume responsibility for any problems arising out of the use of these circuits or for any infringement of third party patent and other right due to same.

CXA1518S

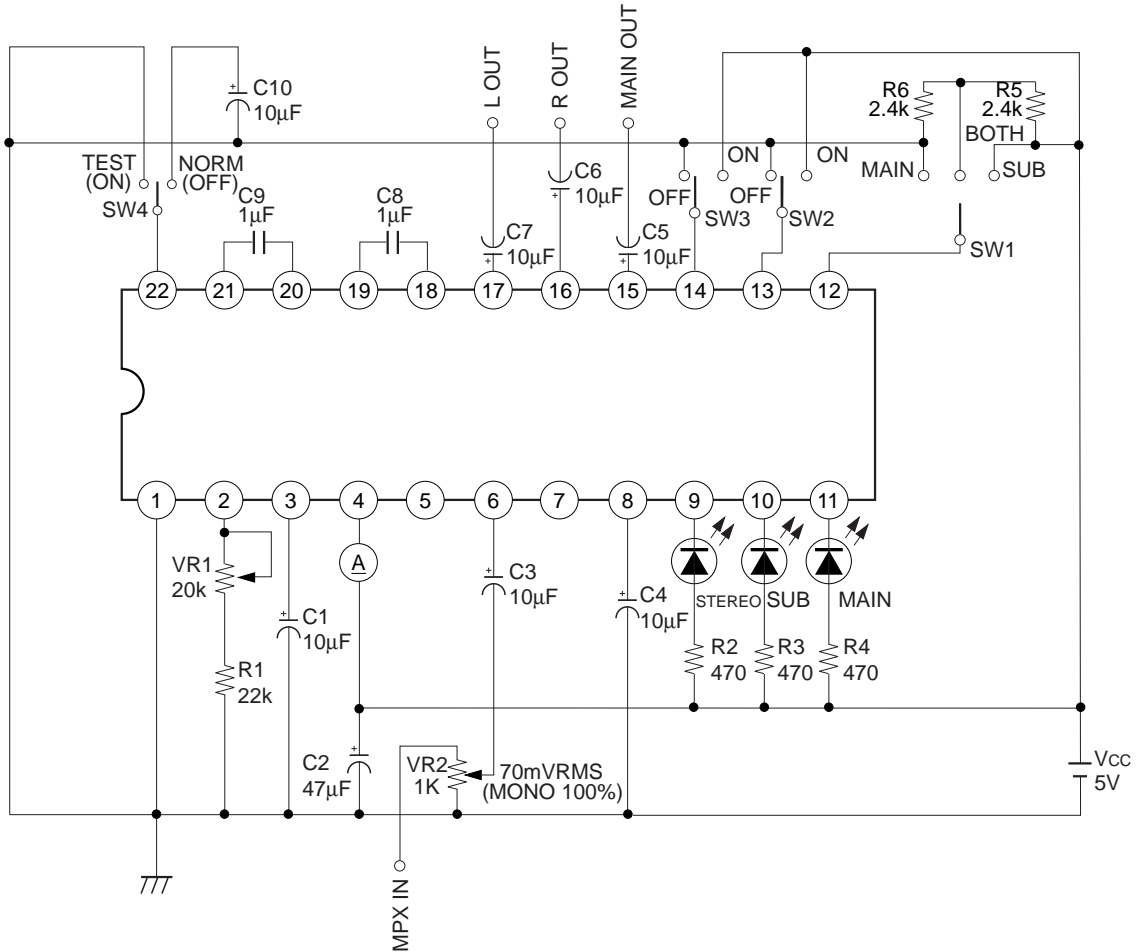

- * Non-polar capacitor is recommended for C8 and C9.
- * NC pin is left open.

Application circuits shown are typical examples illustrating the operation of the devices. Sony cannot assume responsibility for any problems arising out of the use of these circuits or for any infringement of third party patent and other right due to same.

De-emphasis characteristics

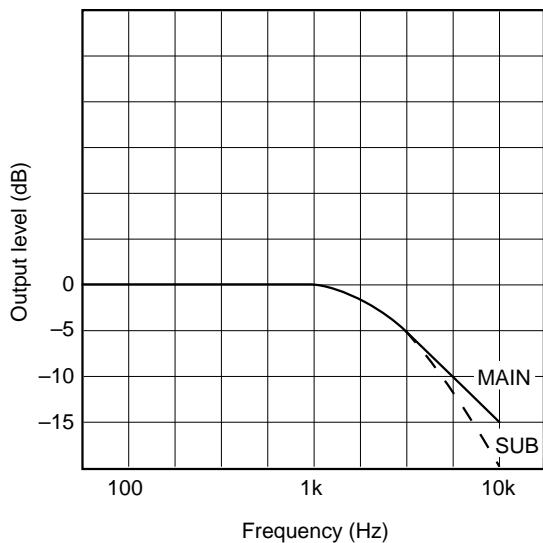

SUB BPF frequency characteristics

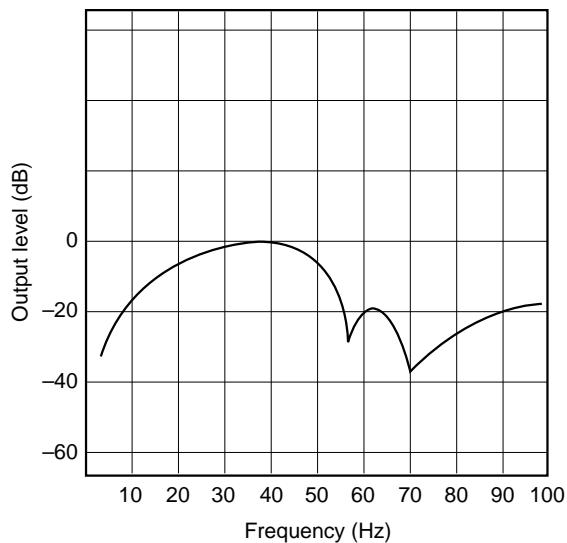

Cue BPF frequency characteristics

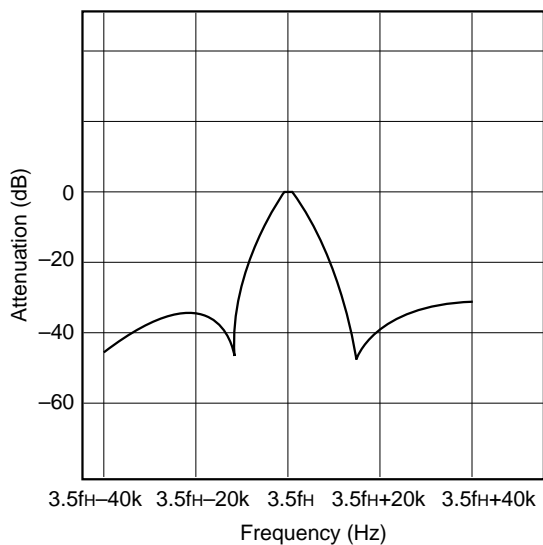

MAIN distortion characteristics

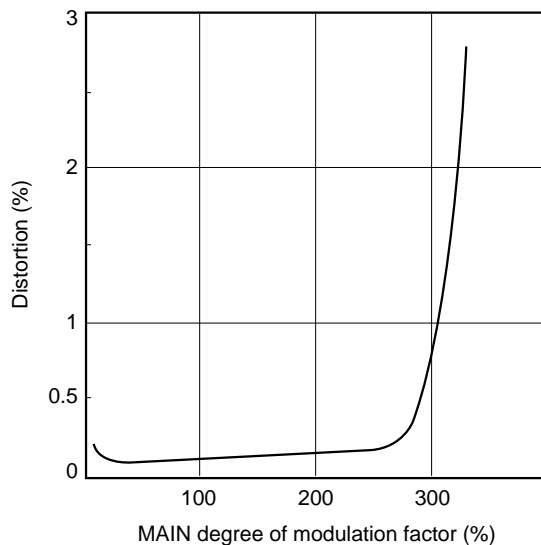

Package Outline Unit : mm

CXA1518Q

32PIN QFP (PLASTIC)

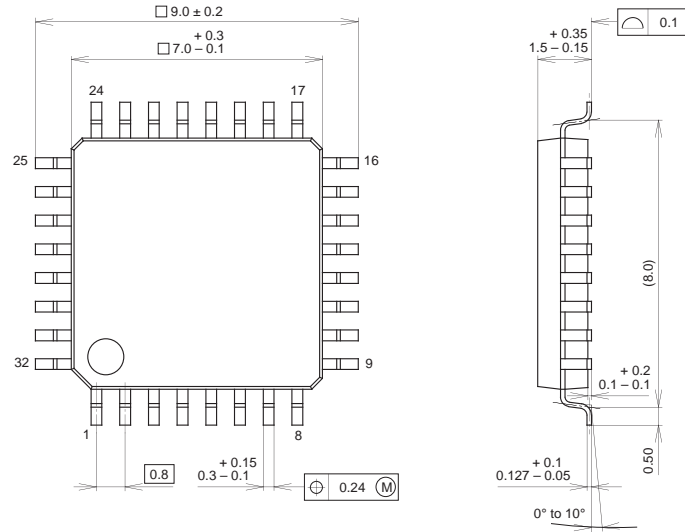

SONY CODE	QFP-32P-L01
EIAJ CODE	QFP032-P-0707
JEDEC CODE	

PACKAGE MATERIAL	EPOXY RESIN
LEAD TREATMENT	SOLDER PLATING
LEAD MATERIAL	42 ALLOY
PACKAGE MASS	0.2g

CXA1518S

22PIN SDIP (PLASTIC)

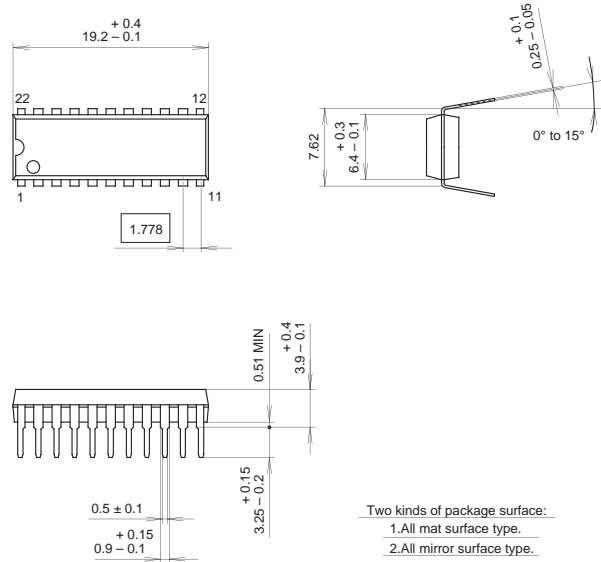

SONY CODE	SDIP-22P-01
EIAJ CODE	SDIP022-P-0300
JEDEC CODE	

PACKAGE STRUCTURE

MOLDING COMPOUND	EPOXY RESIN
LEAD TREATMENT	SOLDER PLATING
LEAD MATERIAL	COPPER ALLOY
PACKAGE MASS	0.95g

This datasheet has been downloaded from:

www.DatasheetCatalog.com

Datasheets for electronic components.



LittleDiode supplies new, hard to find or obsolete electronic components and semiconductors all over the world.

With over two million different components listed you are sure to find the part you need.

Feel free to visit us today at our online store:

LittleDiode.com

Looking forward to providing you with the best possible service.