

## RGB Encoder

### Description

The CXA1645P/M is an encoder IC that converts analog RGB signals to a composite video signal. This IC has various pulse generators necessary for encoding. Composite video outputs and Y/C outputs for the S terminal are obtained just by inputting composite sync, subcarrier and analog RGB signals.

It is best suited to image processing of personal computers and video games.

### Features

- Single 5V power supply
- Compatible with both NTSC and PAL systems
- Built-in 75Ω drivers (RGB output, composite video output, Y output, C output)
- Both sine wave and pulse can be input as a subcarrier.
- Built-in band pass filter for the C signal and delay line for the Y signal
- Built-in R-Y and B-Y modulator circuits
- Built-in PAL alternate circuit
- Burst flag generator circuit
- Half H killer circuit

### Applications

Image processing of video games and personal computers

### Block Diagram and Pin Configuration

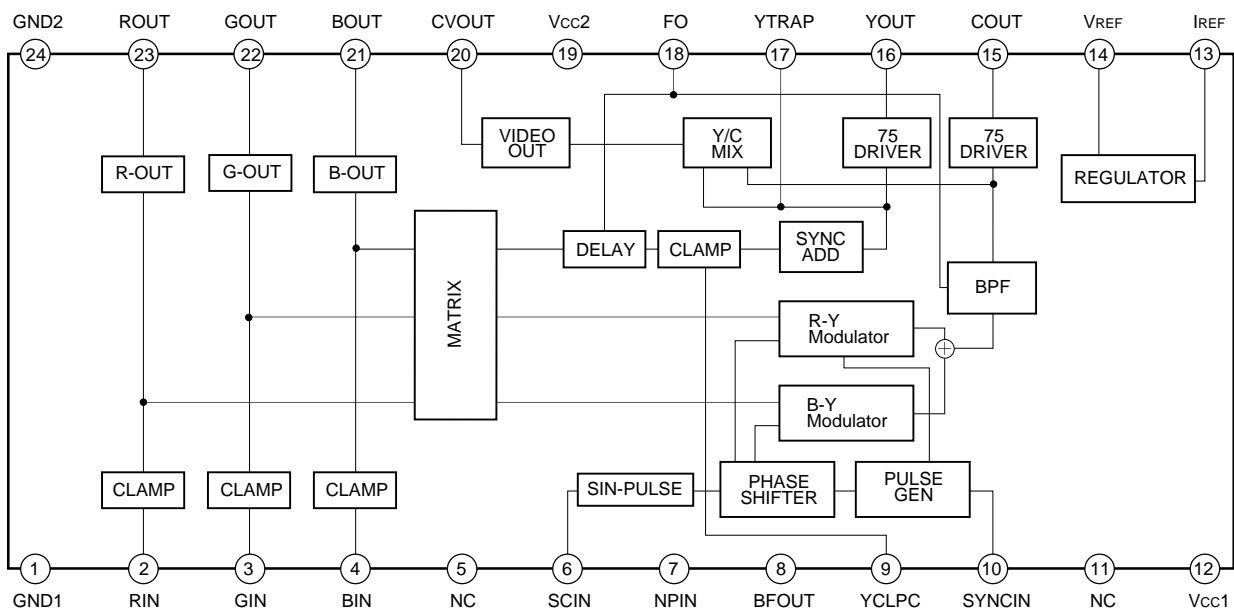

Sony reserves the right to change products and specifications without prior notice. This information does not convey any license by any implication or otherwise under any patents or other right. Application circuits shown, if any, are typical examples illustrating the operation of the devices. Sony cannot assume responsibility for any problems arising out of the use of these circuits.

24 pin DIP (Plastic)

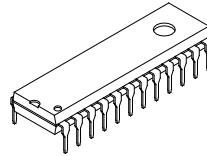

24 pin SOP (Plastic)

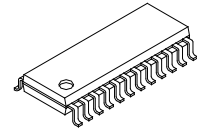

### Structure

Bipolar silicon monolithic IC

### Absolute Maximum Ratings

- Supply voltage  $V_{CC}$  14 V
- Operating temperature  $T_{opr}$  -20 to +75 °C
- Storage temperature  $T_{stg}$  -65 to +150 °C
- Allowable power  $P_D$  CXA1645P 1250 mW  
CXA1645M 780 mW

### Recommended Operating Condition

- Supply voltage  $V_{CC1, 2}$  5.0 ± 0.25 V

Pin Description

\* Externally applied voltage

Pin No.	Symbol	Pin voltage	Equivalent circuit	Description
1	GND1	0V*		Ground for all circuits other than RGB, composite video and Y/C output circuits. The leads to GND2 should be as short and wide as possible.
2 3 4	RIN GIN BIN	Black level when clamped 2.0V		Analog RGB signal inputs. Input 100%, = 1Vp-p (max.). To minimize clamp error, input at as low impedance as possible. ICLP turns ON only in the burst flag period.
5	NC			NO CONNECTION
6	SCIN	—		Subcarrier input. Input 0.4 to 0.5Vp-p sine wave or pulse. Refer to Notes on Operation, Nos. 3 and 5.
7	NPIN	1.7V		Pin for switching between NTSC and PAL modes NTSC: Vcc, PAL: GND
8	BFOUT	H : 3.6V L : 3.2V		BF pulse monitoring output. Incapable of driving a 75Ω load.

Pin No.	Symbol	Pin voltage	Equivalent circuit	Description
9	YCLPC	2.5V		<p>Pin to determine the Y signal clamp time constant. Connect to GND via a 0.1µF capacitor.</p>
10	SYNC IN	2.2V		<p>Composite sync signal input. Input TTL-level voltages. L (<math>\leq 0.8V</math>): SYNC period H (<math>\geq 2.0V</math>)</p>
12	Vcc1	5.0V*		<p>Power supply for all circuits other than RGB, composite video and Y/C output circuits. Refer to Notes on Operation, Nos. 4 and 10.</p>
13	IREF	2.0V		<p>Pin to determine the internal reference current. Connect to GND via a 47kΩ resistor.</p>
14	VREF	4.0V		<p>Internal reference voltage. Connect a decoupling capacitor of approximately 10µF. Refer to Notes on Operation, Nos. 4 and 7.</p>

Pin No.	Symbol	Pin voltage	Equivalent circuit	Description
15	COUT	2.2V		<p>Chroma signal output. Capable of driving a 75Ω load.</p> <p>Refer to Notes on Operation, Nos. 6 and 9.</p>
16	YOUT	Black level 1.3V		<p>Y signal output. Capable of driving a 75Ω load.</p> <p>Refer to Notes on Operation, Nos. 6 and 9.</p>
17	YTRAP	Black level 1.6V	<p>Input resistance 1.5kΩ</p>	<p>Pin for reducing cross color caused by the subcarrier frequency component of the Y signal. When the CVOOUT pin is in use, connect a capacitor or a capacitor and an inductor in series between YTRAP and GND. Decide capacitance and inductance, giving consideration to cross color and the required resolution.</p> <p>No influence on the YOUT pin.</p> <p>Refer to Notes on Operation, No. 8.</p>
18	FO	2.0V		<p>Internal filter fo adjustment pin.</p> <p>Connect to GND via the following resistor according to the NTSC or PAL mode.</p> <p>NTSC: 20kΩ (±1%)</p> <p>PAL : 16kΩ (±1%)</p>

Pin No.	Symbol	Pin voltage	Equivalent circuit	Description
19	Vcc2	5.0V*		<p>Power supply for RGB, composite video and Y/C output circuits. Decouple this pin with a large capacitor of 10μF or above as a high current flows.</p> <p>Refer to Notes on Operation, Nos. 4 and 10.</p>
20	CVOUT	Black level 1.2V		<p>Composite video signal output. Capable of driving a 75Ω load.</p> <p>Refer to Notes on Operation, Nos. 6 and 9.</p>
21 22 23	BOUT GOUT ROUT	Black level 1.7V		<p>Analog RGB signal outputs. Capable of driving a 75Ω load.</p> <p>Refer to Notes on Operation, Nos. 6 and 9.</p>
24	GND2	0V*		<p>Ground for RGB, composite video and Y/C output circuits. The leads to GND1 should be as short and wide as possible.</p>

**Electrical Characteristics** (Ta = 25°C, Vcc = 5V, See the Electrical Characteristics Measurement Circuit.)

Item	Symbol	S1	S2	S3	S4	S5	Measurement point	Measurement Conditions	Min.	Typ.	Max.	Unit	
		RIN GIN BIN	SCIN	NPIN	SYNC IN	FO							
Current consumption 1	Icc1	2V	SG4	5V	SG5	20k	Icc1	No input signal, SG5: CSYNC TTL level, SG4: SIN wave 3.58MHz 0.5Vp-p Fig. 1		31		mA	
Current consumption 2	Icc2						Icc2						
(R, G, BOUT)													
RGB output voltage	Vo (R)	SG1					D	SG1 to SG3: DC direct coupling 2.5Vdc, 1.0Vp-p f = 200kHz Pin 9 = Clamp voltage Fig. 2	0.64	0.71	0.78	Vp-p	
	Vo (G)	SG2			2V	E							
	Vo (B)	SG3				F							
RGB output frequency characteristics	fc (R)	SG1					D	SG1 to SG3: DC direct coupling 2.5Vdc, 1.0Vp-p f = 200kHz/5MHz Pin 9 = Clamp voltage Fig. 3	-3.0			dB	
	fc (G)	SG2			2V	E							
	fc (B)	SG3				F							
(YOUT & CVOUT)													
Output sync level	Vo (YS1/2)	SG1 to SG3	0V	5V	SG5	20k	B/C	SG1 to SG3: 100% color bar input, 1.0Vp-p (Max.) SG5: CSYNC TTL level Fig. 4	0.26	0.29	0.33	Vp-p	
R100%: Y level	Vo (YR1/2)								0.17	0.21	0.26	V	
G100%: Y level	Vo (YG1/2)								0.35	0.42	0.49	V	
B100%: Y level	Vo (YB1/2)								0.065	0.08	0.095	V	
White 100%: Y level	Vo (YW1/2)								0.6	0.71	0.82	V	
Output frequency characteristics	fc (Y1/2)	SG1 to SG3	0V	5V	2V	20k		SG1 to SG3: DC direct coupling 2.5Vdc, 1.0Vp-p f = 200kHz/5MHz Pin 9 = Clamp voltage Fig. 3	-3.0				dB

\* Clamp voltage: voltage appearing at Pin 9 when CSYNC is input.

Item	Symbol	S1	S2	S3	S4	S5	Measurement point	Measurement Conditions	Min.	Typ.	Max.	Unit
		RIN GIN BIN	SCIN	NPIN	SYNC IN	FO						
(COUT & CVOUT)												
Burst level	Vo (BN1/2)	SG1 to SG3	SG4	5V	SG5	20k	A/C	SG1 to SG3: 100% color bar input, 1.0Vp-p (Max.) SG4: SIN wave, 3.58MHz 0.5Vp-p SG5: CSYNC TTL level Fig. 5	0.2	0.25	0.3	Vp-p
R chroma ratio	R/BN1/2								2.84	3.16	3.48	
R phase	$\theta_{R1/2}$								94	104	114	deg
G chroma ratio	G/BN1/2								2.65	2.95	3.25	
G phase	$\theta_{G1/2}$								231	241	251	deg
B chroma ratio	B/BN1/2								2.01	2.24	2.47	
B phase	$\theta_{B1/2}$								337	347	357	deg
Burst width	$t_w(B)_{1/2}$								2.5	2.75	3.2	$\mu s$
Burst position	$t_d(B)_{1/2}$								0.4	0.6	0.75	$\mu s$
Carrier leak	V <sub>L1/2</sub>	SG1 to SG3	SG4	5V	SG5	20k	A/C	SG1 to SG3: No signal, SG4: SIN wave, 3.58MHz 0.5Vp-p SG5: CSYNC TTL level 3.58MHz component measured. Fig. 6			20	mVp-p
PAL burst level ratio	K (BP1/2)	SG1 to SG3	SG4	GND	SG5	16k	A/C	SG1 to SG3: No signal, SG4: SIN wave, 4.43MHz 0.5Vp-p SG5: CSYNC TTL level Fig. 6	0.9	1.0	1.1	
PAL burst phase	$\theta_{PAL1/2}$								125	135	145	deg
	$\overline{\theta_{PAL1/2}}$								215	225	235	

\* Clamp voltage: voltage appearing at Pin 9 when CSYNC is input.

Electrical Characteristics Measurement Circuit

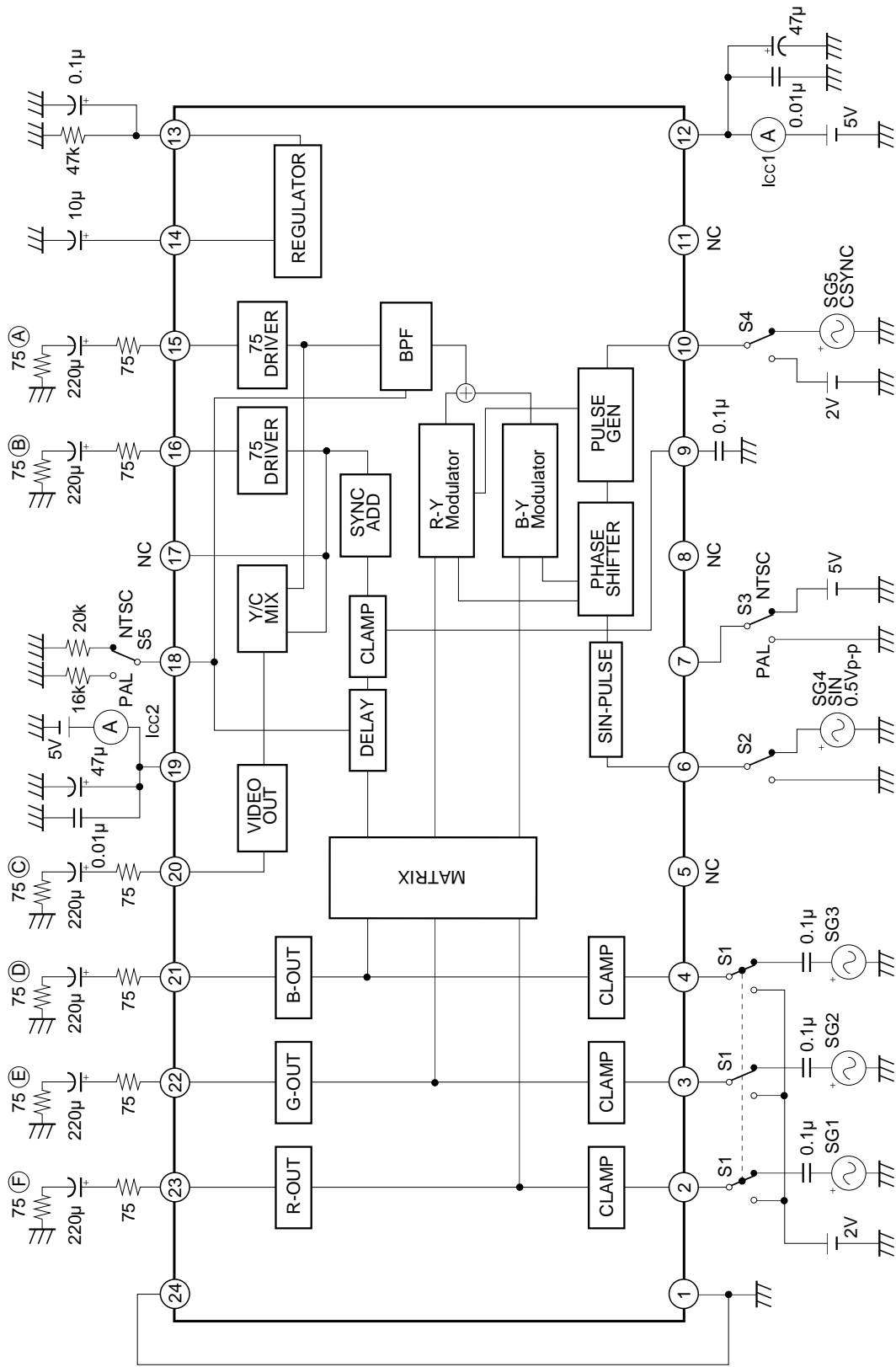

SG1 to SG3 100% color bar (1Vp-p max.)

Measuring Signals and Output Waveforms

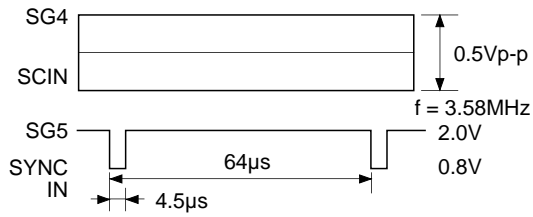

Fig. 1

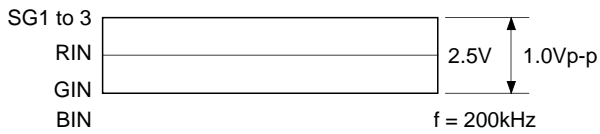

Fig. 2

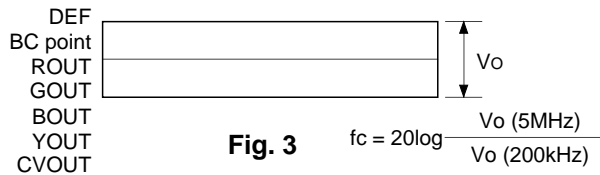
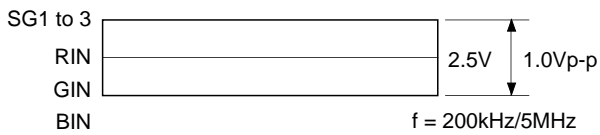

Fig. 3

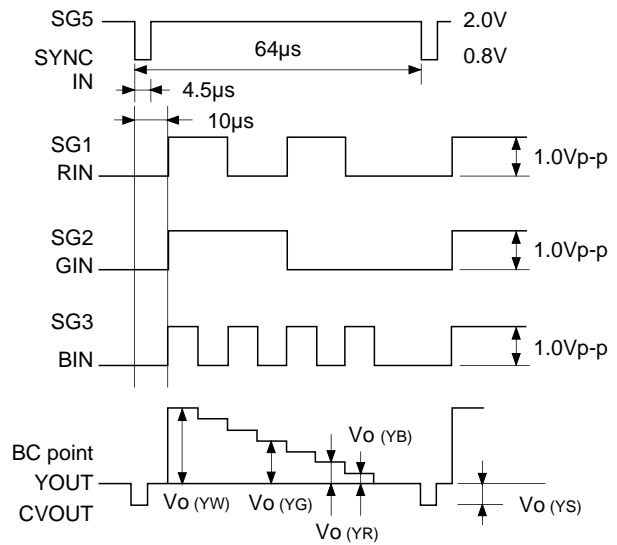
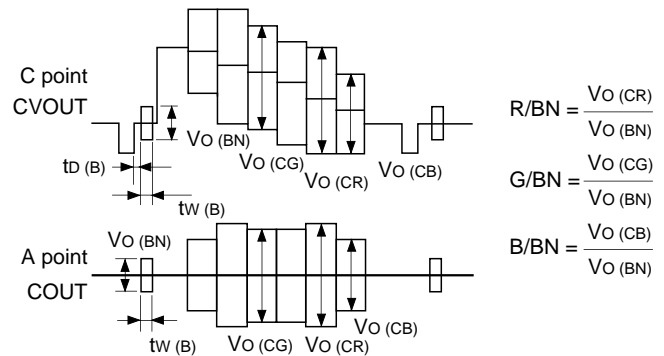
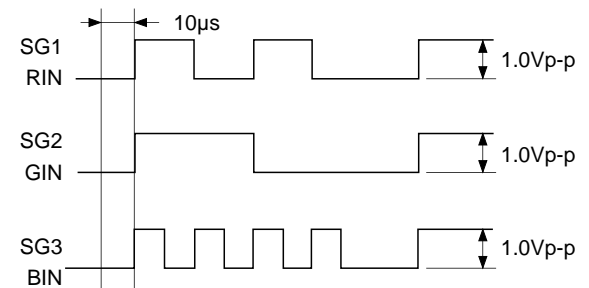
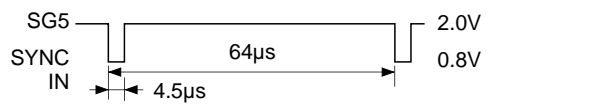
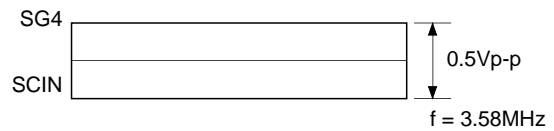

Fig. 4



$$R/BN = \frac{Vo (CR)}{Vo (BN)}$$

$$G/BN = \frac{Vo (CG)}{Vo (BN)}$$

$$B/BN = \frac{Vo (CB)}{Vo (BN)}$$

Fig. 5

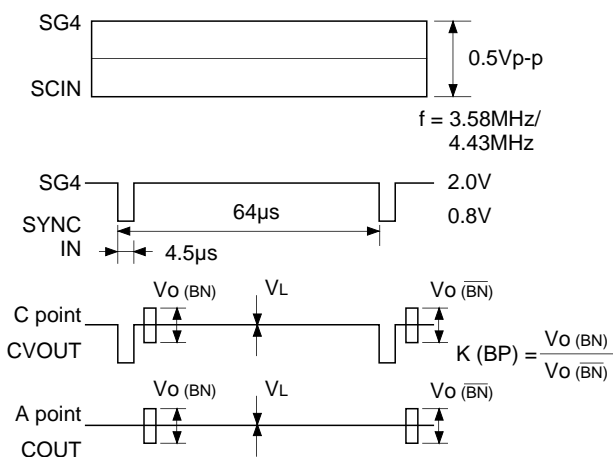

$$K (BP) = \frac{Vo (BN)}{Vo (BN)}$$

Fig. 6

Application Circuit (NTSC mode)

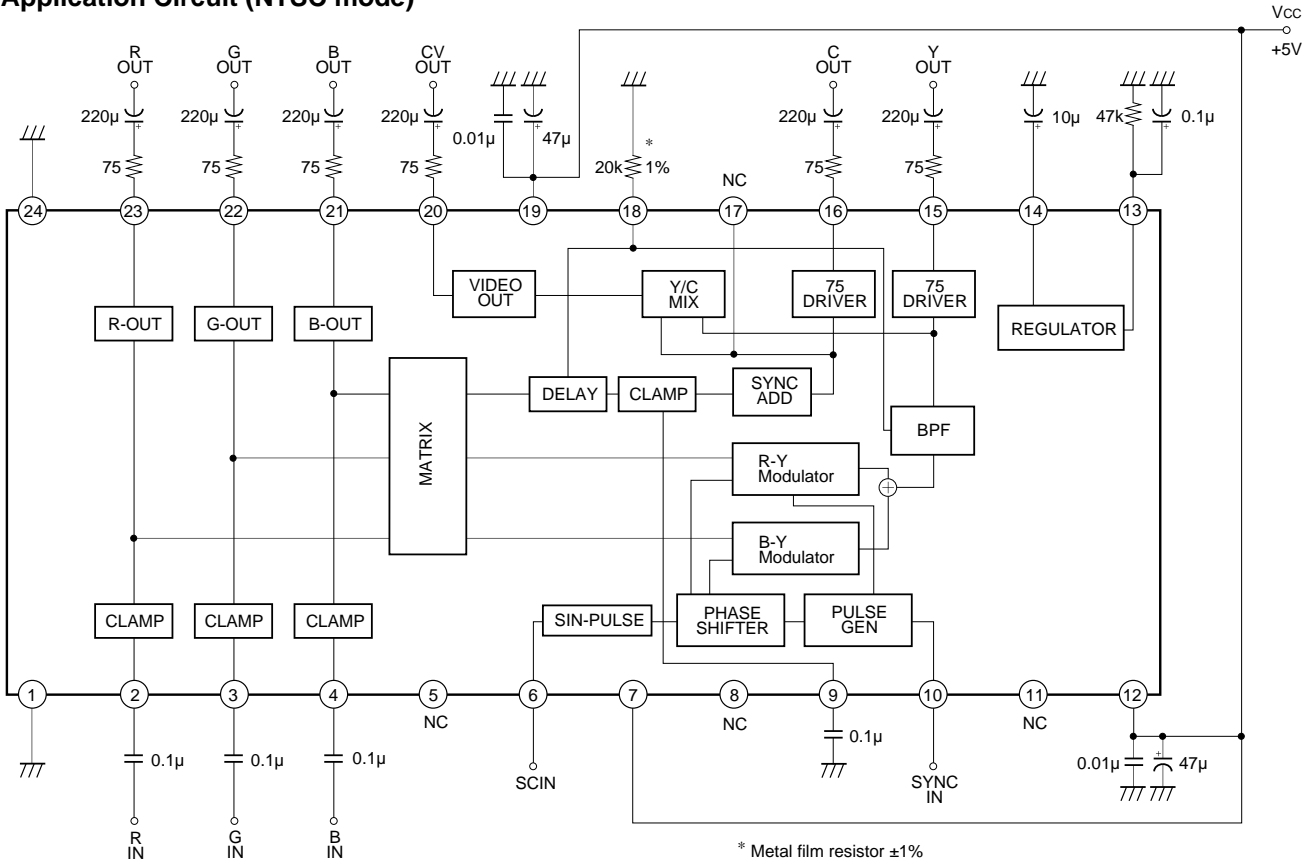

Application Circuit (PAL mode)

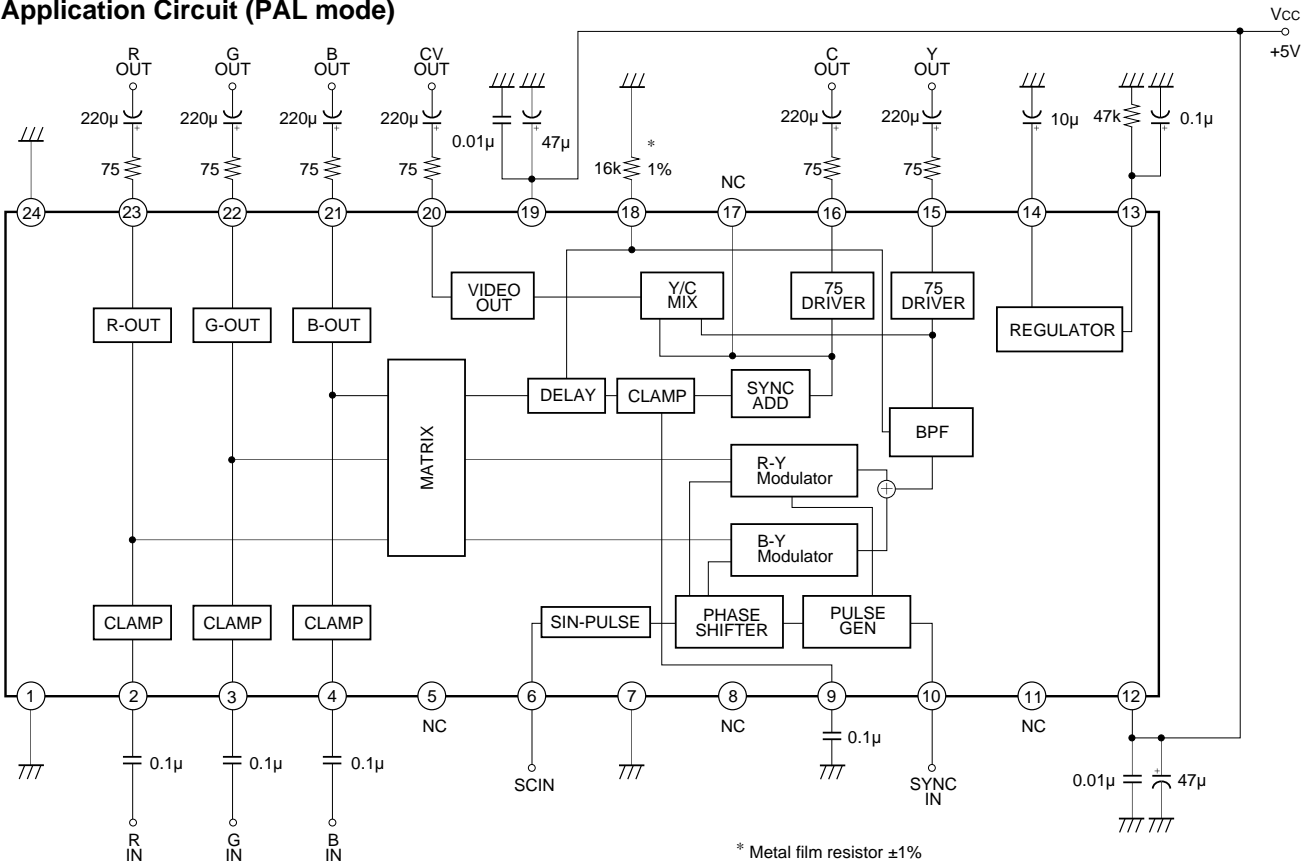

Application circuits shown are typical examples illustrating the operation of the devices. Sony cannot assume responsibility for any problems arising out of the use of these circuits or for any infringement of third party patent and other right due to same.

**Description of Operation**

Analog RGB signals input from Pins 2, 3 and 4 are clamped in the clamping circuit and output from Pins 23, 22 and 21, respectively.

The matrix circuit performs operations on each input signal, generating luminance signal Y and color difference signals R-Y and B-Y. The Y signal enters the delay line to adjust delay time with the color signal C. Then, after addition of the CSYNC signal input from Pin 10, the Y signal is output from Pin 16.

A subcarrier input from Pin 6 is input to the phase shifter, where its phase is shifted 90°. Then, the subcarrier is input to the modulators and modulated by the R-Y signal and the B-Y signal. Modulated subcarriers are mixed, sent to the band pass filter to eliminate higher harmonic components and finally output from Pin 15 as the C signal. At the same time, Y and C signals are mixed and output from Pin 20 as the composite video signal.

**Burst Signal**

The CXA1645P/M generates burst signals at the timing shown below according to the composite sync signal input.

H synchronization

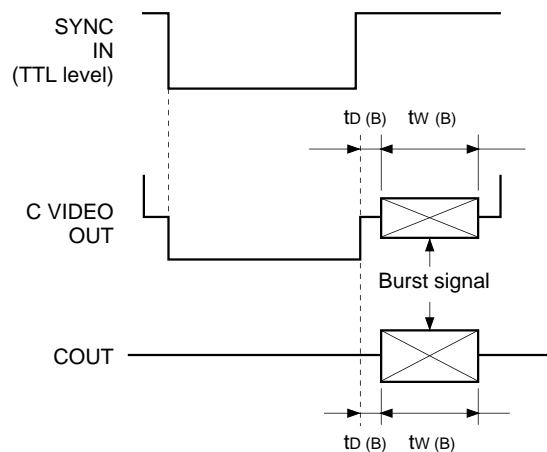

V synchronization

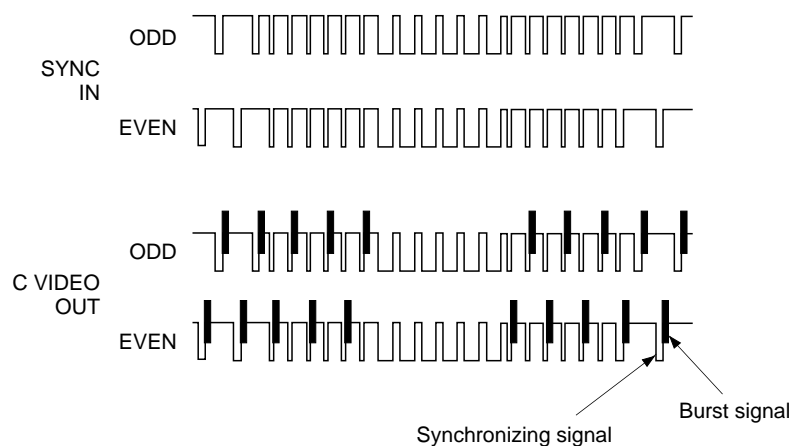

**Notes on Operation**

Be careful of the following when using the CXA1645P/M.

1. This IC is designed for image processing of personal computers and video games. When using the IC in other video devices, make thorough investigations on image quality.
2. Be sure that analog RGB signals are input at 1.0Vp-p maximum and have low enough impedance. High impedance may affect color saturation, hue, etc. Inputting RGB signals in excess of 1.3Vp-p may disable the clamp operation.
3. The SC input (Pin 6) can be either a sine wave or a pulse in the range from 0.4 to 5.0Vp-p. However, when a pulse is input, its phase may be shifted several degrees from that of the sine wave input. In the IC, the SC input is biased to 1/2 V<sub>CC</sub>. Accordingly, when a 5.0Vp-p pulse is input and the duty factor deviates from 50%, High- and Low-level pulse voltages may exceed V<sub>CC</sub> and GND in the IC, which causes subcarrier distortion. In such a case, be very careful that the duty factor keeps to 50%.
4. When designing a printed circuit board pattern, pay careful attention to the routing of the V<sub>CC</sub> and GND leads. To decouple the V<sub>CC</sub> and V<sub>REF</sub> pins, use tantalum, ceramic or other capacitors with good frequency characteristics. Ground the capacitors by connections shown below as closely to each IC pin as possible. Try to design the leads as short and wide as possible.

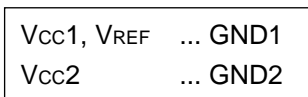

Design the pattern so that V<sub>CC</sub> (or V<sub>REF</sub>) is connected to GND via a capacitor at the shortest distance.

5. SC and SYNC input pulses

Attach a resistor and a capacitor to eliminate high-frequency components of SC (Figure A) and SYNC (Figure B) before input.

**Fig. A**

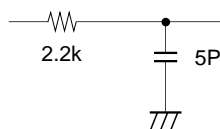

**Fig. B**

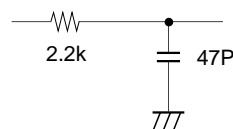

Be careful not to input pulses containing high-frequency components. Otherwise, high-frequency components may flow into V<sub>CC</sub>, GND and peripheral parts, resulting in malfunctions.

6. Connecting an external resistor to the 75Ω driver output pin

A capacitance of several dozen picofarads at each pin may start oscillation. To prevent oscillation, design the pattern so that a 75Ω resistor is mounted near the pin (see Figure C).

**Fig. C**

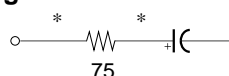

\* Make these leads short.

When any of the 75Ω driver output pins is not in use, leave it unconnected and design the pattern so that no parasitic capacitance is generated on the printed circuit board.

7. VREF pin (Pin 14)

Do not connect this pin to an external load that might cause AC signals to flow, which will cause IC malfunctions. When connecting a DC load, make sure that the current flowing from this pin is kept below 2mA.

8. YTRAP pin (Pin 17)

There are the following two means of reducing cross color generated by subcarrier frequency components contained in the Y signal.

- (1) Install a capacitor of 30 to 68pF between YTRAP and GND. Decide the capacitance by conducting image evaluation, etc., giving consideration to both cross color and resolution.

Relations between capacitance and image quality are as follows:

Capacitance	30pF ↔ 68pF
Cross color	Large ↔ Small
Resolution	High ↔ Low

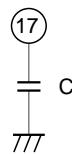

- (2) Connect a capacitor C and an inductor L in series between YTRAP and GND. When the subcarrier frequency is fo, the values C and L are determined by the equation  $f_0 = \frac{1}{2\pi\sqrt{LC}}$ . Decide the values in image evaluation, etc., giving consideration to both cross color and resolution.

Relations between inductor values and image quality are as follows:

Inductor value	Small ↔ Large
Cross color	Large ↔ Small
Resolution	High ↔ Low

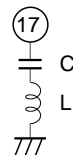

For instance, L = 68μH and C = 28pF are recommended for NTSC. It is necessary to select an inductor L with a sufficiently small DC resistance. Method (2) is more useful for achieving a higher resolution than method (1). When an even higher resolution is necessary, use of the S terminal (YOUT and COUT) is recommended.

- 9. Driving COUT (Pin 15), YOUT (Pin 16), CVOUT (Pin 20), and B.G.R OUT (Pins 21, 22 and 23) outputs  
In Pin Description, "Capable of driving a 75Ω load" means that the pin can drive a capacitor +75Ω +75Ω load shown in the figure below. In other words, the pin is capable of driving a 150Ω load in AC.

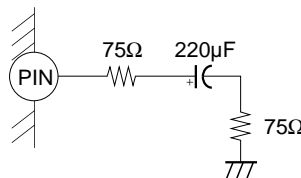

Keep in mind that the pin is incapable of driving a 150Ω load in DC load in DC direct coupling.

- 10. This IC employs a number of 75Ω driver pins, so oscillation is likely to occur when measures described in Nos. 4 and 6 are not taken thoroughly. Be very careful of oscillation in printed circuit board design and carry out thorough investigations in the actual driving condition.

Package Outline

Unit: mm

CXA1645P

24PIN DIP (PLASTIC) 400mil

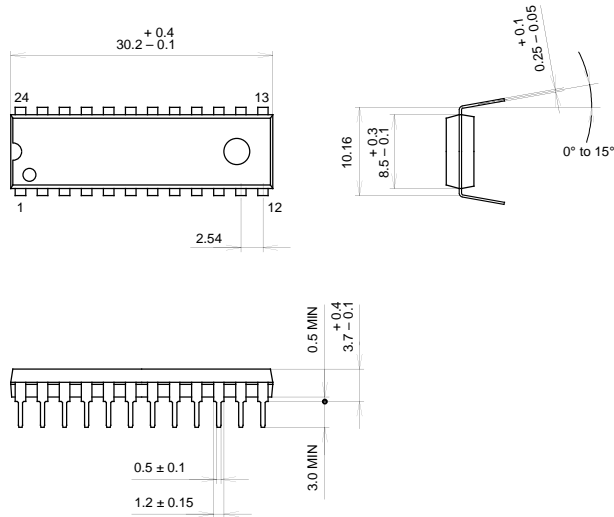

SONY CODE	DIP-24P-01
EIAJ CODE	*DIP024-P-0400-A
JEDEC CODE	_____

PACKAGE STRUCTURE

PACKAGE MATERIAL	EPOXY RESIN
LEAD TREATMENT	SOLDER PLATING
LEAD MATERIAL	COPPER / 42 ALLOY
PACKAGE WEIGHT	2.0g

CXA1645M

24PIN SOP (PLASTIC)

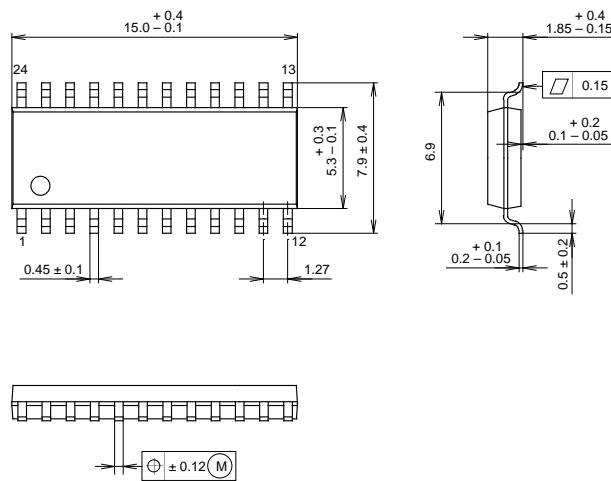

SONY CODE	SOP-24P-L01
EIAJ CODE	*SOP024-P-0300-A
JEDEC CODE	_____

PACKAGE STRUCTURE

MOLDING COMPOUND	EPOXY/PHENOL RESIN
LEAD TREATMENT	SOLDER PLATING
LEAD MATERIAL	COPPER ALLOY / 42ALLOY
PACKAGE WEIGHT	0.3g

This datasheet has been downloaded from:

[www.DatasheetCatalog.com](http://www.DatasheetCatalog.com)

Datasheets for electronic components.



LittleDiode supplies new, hard to find or obsolete electronic components and semiconductors all over the world.

With over two million different components listed you are sure to find the part you need.

Feel free to visit us today at our online store:

[LittleDiode.com](http://LittleDiode.com)

Looking forward to providing you with the best possible service.