

# CXA1700AQ/AR

## Luminance and Color Signal Processing for 8mm VCR

**Description**

The CXA1700AQ/AR is an IC designed for 8mm VCR Y/C main signal processing for consumer use.

Equipped with many built-in filters, the CXA1700AQ/AR is a one-chip main signal processing system that greatly reduces the number of external components.

**Features**

- Built-in auto-adjusting filters
- Supports simple Hi-8 video.
- Supports camera recording.
- Supports power saving mode.
  - 140mW for composite signal input
  - 250mW for separate signal input
- Supports electronic volume (EVR) control.
- Supports BUS LINE.
- Supports NTSC/PAL.

**Function**

2-input INPUT SELECT, VIDEO AGC, DDS (Y signal superimposition), synchronous separation, 75Ω VIDEO OUT DRIVE, Y/C mixing, Y/C separation comb filter, Y/C cross talk elimination, playback chroma feedback comb, Y dropout compensation, Yd playback switching, Y signal H correlation detection, Y pre-emphasis/de-emphasis, white/dark clipping, clipping compensation, MOD/DEMODO, HHS/HHS cancel, ACC, chroma emphasis/de-emphasis, burst emphasis/de-emphasis, XO/VXO, APC, AFC, APC ID, AFC ID, burst ID, ACK, APC compensation, HHK, PI/PS, frequency conversion system, PB C BPF, REC C LPF, PB C LPF, CARRIER BPF, 4.1V regulator

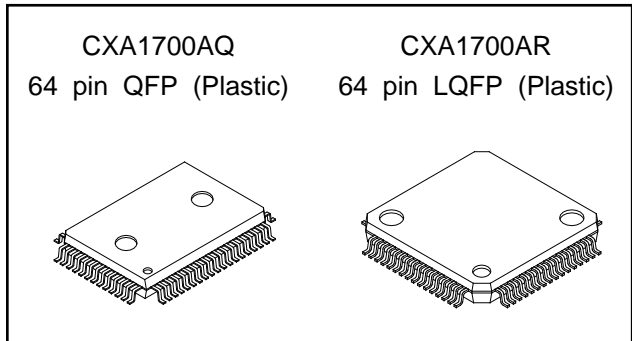

**Structure**

Bipolar silicon monolithic IC

**Absolute Maximum Ratings (Ta=25°C)**

- Supply voltage Vcc 7 V
- Operating temperature Topr -10 to +75 °C
- Storage temperature Tstg -65 to +150 °C
- allowable power dissipation  
(when mounted on board)

PD	CXA1700AQ	1050	mW
	CXA1700AR	1010	mW

**Operating Condition**

- Supply voltage Vcc 4.75<sup>+0.5</sup><sub>-0.25</sub> V

Sony reserves the right to change products and specifications without prior notice. This information does not convey any license by any implication or otherwise under any patents or other right. Application circuits shown, if any, are typical examples illustrating the operation of the devices. Sony cannot assume responsibility for any problems arising out of the use of these circuits.

**Block Diagram and Pin Configuration**  
(CXA1700AQ)

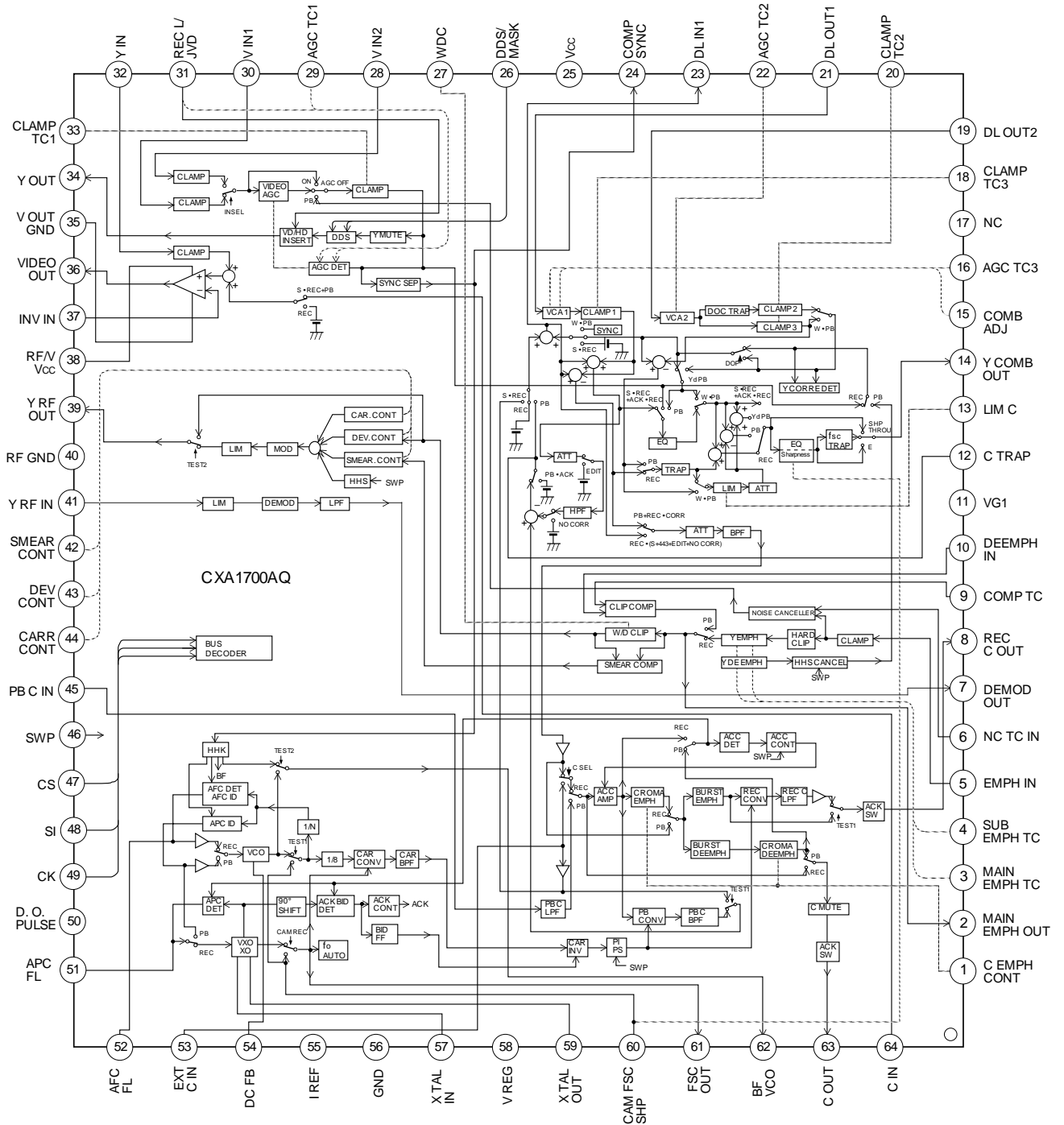

Block Diagram and Pin Configuration  
(CXA1700AR)

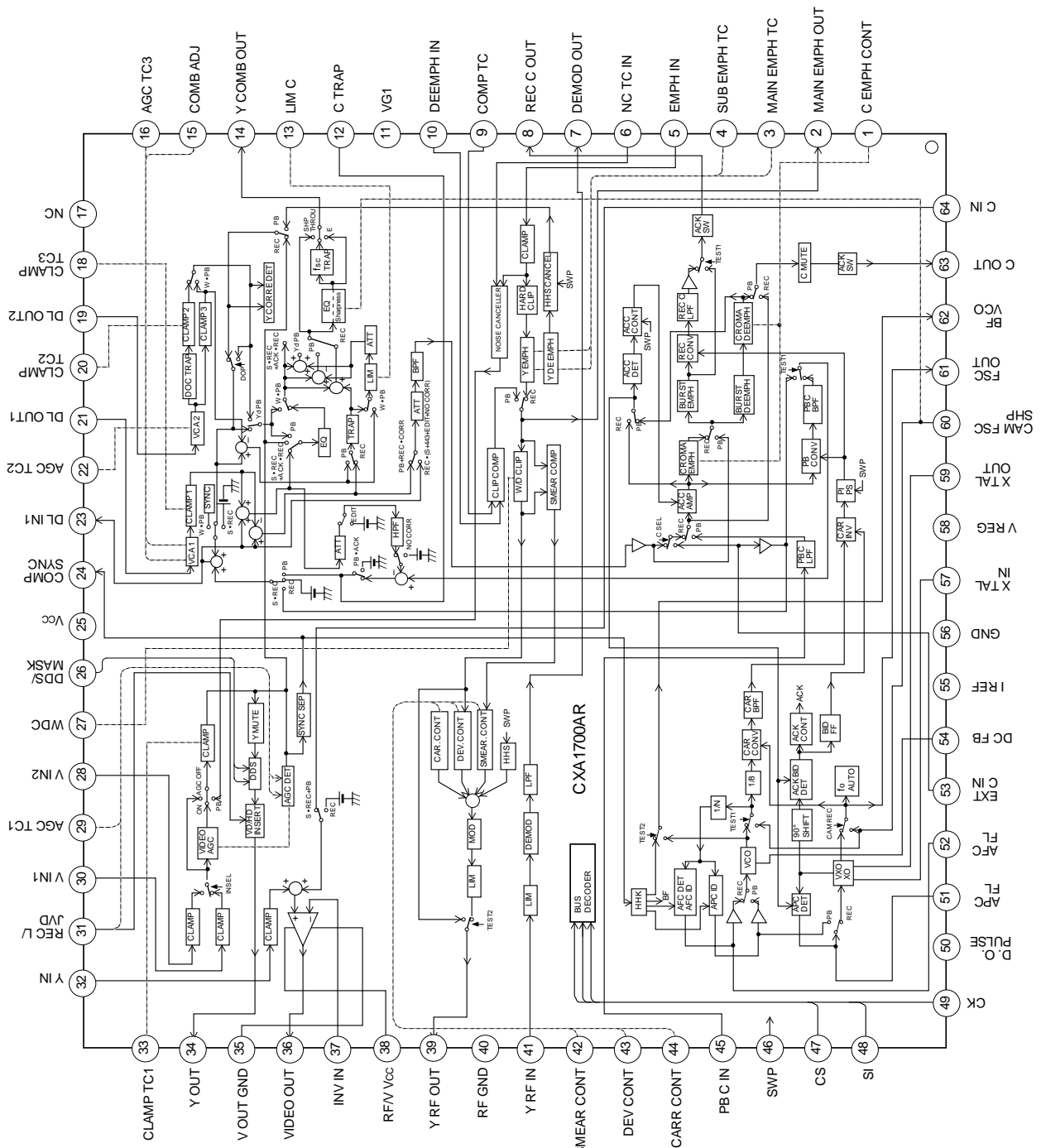

Pin Description

Pin No.	Symbol	Pin voltage		Equivalent circuit	Description
		DC	AC		
1	C EMPH CONT	Control range: 1.8V to 3.8V	—		Chroma emphasis fo (center frequency) adjustment. (Refer to item 7 on Description of Operation.)
2	MAIN EMPH OUT	2.05V (sync tip level)	 250mVp-p Output		Main emphasis and main de-emphasis time constant. When recording, the emphasized Y signal prior to white/dark clipping is output.
3	MAIN EMPH TC	2.05V (when time constant connected)	—		Main emphasis and main de-emphasis time constant. Apply an external constant between this pin and Pin 2, as shown below. 
4	SUB EMPH TC	2.05V (when time constant connected)	—		HPF time constant that forms sub emphasis and sub de-emphasis. Add resistance between this pin and Pin 11. 
5	EMPH IN	2.05V (sync tip level)	 500mVp-p Input		During recording, Y emphasis input. During playback, this signal to the noise canceler is input. Performs diode clamping (sync tip clamping), with the clamp capacitance attached externally.

Pin No.	Symbol	Pin voltage		Equivalent circuit	Description
		DC	AC		
6	NCTC IN	2.05V (when time constant connected)	—		Connects external time constant for HPF of noise canceler. (Refer to item 11 on Description of Operation.)
7	DEMODO OUT	1.6V	140mVp-p output during standard playback 		Y signal output that has been FM demodulated and has passed through the DEMOD LPF.
8	REC C OUT	2.0V	Low-frequency conversion chroma signal 300mVp-p output		During recording, a chroma signal that has been burst emphasized, chroma emphasized, and frequency converted is output. During ACK, the output DC goes to 0V. During recording, if TEST1 is High the burst emphasized signal is output.
9	COMP TC	2.05V (when time constant connected)	—		Connects external time constant for HPF of the white/dark clipping compensation circuit during playback.
10	DEEMPH IN	2.05 V (center DC)	180mVp-p input during playback 		Input for de-emphasis circuit during playback. The signal is input to the de-emphasis circuit through the clipping compensation circuit.

Pin No.	Symbol	Pin voltage		Equivalent circuit	Description
		DC	AC		
11	VG1	2.05V	—		Internal reference voltage source. (Can not be used as external bias for Pins other than 4, 6, and 9.)
12	C TRAP	2.05V	Chroma signal 300mVp-p output during playback		Outputs chroma signal that has passed through PB C BPF and chroma feedback comb filter subtracter after frequency conversion during playback.
13	LIM C	2.4V	—		Connects decoupling capacitor for limiter of the playback Y comb block.
14	Y COMB OUT	1.2V (sync tip level)	Y signal 500mVp-p output		Outputs Y signal processed by comb filter. During playback, the signal is output through the sharpness circuit. If mode E is set High, the signal is output without passing through the f <sub>sc</sub> Trap; if mode SHP THRU is set High, the signal is output without passing through the sharpness circuit.
15	COMB ADJ	Control range: 1.8V to V <sub>cc</sub>	—		VCA gain adjustment in the comb filter block. (Refer to Adjustment Procedure.)

Pin No.	Symbol	Pin voltage		Equivalent circuit	Description
		DC	AC		
16	AGC TC3	2.2V to 4.0V	—		Time constant for VCA circuit in comb filter block. A DC limiter circuit with an upper limit of 4.0V and a lower limit of 2.2V is built in.
17	NC	—	—		Not connected. Normally, connect to GND.
18	CLAMP TC3	—	—		Time constant for feedback clamp circuit in the comb filter block.
19	DL OUT2	2.1V (center DC)	Video 500mVp-p input		Inputs CCD DL (delay line) output signal to the VCA circuit.
20	CLAMP TC2	—	—		Time constant for feedback clamp circuit in the comb filter block.

Pin No.	Symbol	Pin voltage		Equivalent circuit	Description
		DC	AC		
21	DL OUT1	2.1V (center DC)	Video 500mVp-p input		Inputs CCD DL (delay line) output signal to VCA circuit.
22	AGC TC2	2.2V to 4.0V	—		Time constant for VCA circuit in the comb filter block. A DC limiter circuit with an upper limit of 4.0V and a lower limit of 2.2V is built in.
23	DL IN1	2.2V	Video 500mVp-p output		Output for inputting a signal to the CCD DL (delay line). Normally, Y+C signal is output.
24	COMP SYNC	High : 2.5V, Low : 0V output	—		Composite sync signal output. No output if mode SYNC SEP OFF is set High.
25	Vcc	Vcc=4.75V	—		Main block power supply.

Pin No.	Symbol	Pin voltage		Equivalent circuit	Description
		DC	AC		
26	DDS/MASK	2.0V (when open) (MASK) 1.5V (DDS) 2.3 to 3.0V	—		<p>Input for VOW (character level) signal, VOB (character background) timing pulse of DDS (date display system) and masking timing pulse.</p> <p>MASK : <math>V_{TH} = 1.1V</math>                      DDS : <math>V_{TH} = 2.0V</math></p> <p>By varying the input DC for DDS over a range of 2.3V to 3.0V, the character level can be changed.                      (Refer to item 4 on Description of Operation.)</p>
27	WDC	2.6V (when open)	—		<p>Determines the white/dark clipping levels. When open, the standard white clipping level is 235%, and the dark clipping level is 95%.                      (Mode DC1, 2 = Low, High)                      (Refer to item 5 on Description of Operation.)</p>
28	V IN2	2.05V (sync tip level)	Video 500mVp-p input		<p>Video signal input. Performs diode clamping, with the clamp capacitance externally connected. If the mode MUTE is set High, the charge of the clamp capacitance is discharged.</p>
29	AGC TC1	—	—		<p>Time constant for the video AGC circuit in the I/O block. During mute and playback, the charge of the external capacitance is discharged.</p>



Pin No.	Symbol	Pin voltage		Equivalent circuit	Description
		DC	AC		
30	V IN1	2.05V (sync tip level)	Video 500mVp-p input		Video signal input. Performs diode clamping, with the clamp capacitance externally connected. If the mode MUTE is set High, the charge of the clamp capacitance is discharged.
31	REC L/JVD	1.9V (Typical value during REC LEVEL adjustment)	—		Level adjustment during recording. The adjustment range is 1.3V to 2.6V. During playback, serves as input for JOG (variable speed playback) VD pulse and HD pulse. $V_{TH} = 2.7V$ (Refer to item 3 on Description of Operation.)
32	Y IN	1.6V (sync tip level)	Video 500mVp-p input		Video signal input for video out circuit. Performs diode clamping, with the clamp capacitance externally connected.
33	CLAMP TC1	—	—		Time constant for feedback clamp circuit in I/O block.
34	Y OUT	1.8V (sync tip level)	Video 500mVp-p output		I/O block signal output.

Pin No.	Symbol	Pin voltage		Equivalent circuit	Description
		DC	AC		
35	VOUT GND	0V	—		GND for the video out circuit.
36	VIDEO OUT	1.6V (sync tip level)	Video 2.0Vp-p output		Video out 75Ω driver output.
37	INV IN	1.5V	Video 1.0Vp-p input		Inverted input for V sag compensation for the video out 75Ω driver.
38	RF/V Vcc	Vcc=4.75V	—		Video out circuit and RF system block power supply.
39	Y RF OUT	2.1V	Y FM output  500mVp-p		During recording, FM-modulated Y signal output. If mode TEST2 is set High during recording, the Y signal after white/dark clipping is output.
40	RF GND	0V	—	_____	RF block GND.
41	Y RF IN	—	YFM 200mVp-p input		During playback, inputs Y-RF signal to FM modulation circuit.
42	SMEAR CONT	Control range: 1.8V to Vcc	—		During recording, adjustment for high Luminance Smear Compensation.

Pin No.	Symbol	Pin voltage		Equivalent circuit	Description
		DC	AC		
43	DEV CONT	Control range: 1.8V to Vcc	—		During recording, adjustment for deviation of Y-FM modulation.
44	CARR CONT	Control range: 1.8V to Vcc	—		During recording, adjustment for carrier of Y-FM modulation.
45	PB C IN	3.1V (during playback)	(PB Y RF) + (PB C RF 100mVp-p) input		During playback, chroma RF signal input. PB C LPF is built in, so that a signal with the AFM and ATF components (Y RF + C RF) eliminated can be input.
46	SWP	—	—		RF SWP (switching pulse) and HCHG (head change) pulse input. Half H shift, HHS cancel, ACC channel hold, and PI/PS switching operate at $V_{TH} = 0.7V$ . Yd playback during playback operates at $V_{TH} = 2.05V$ (same as when mode Yd is High).
47	CS	High : Vcc, Low : 0V input	—		Input to BUS DECODER. CS is used as chip select, and data is latched at rising edge. CK is the clock input. Use a clock frequency fck of less than 1.3MHz. SI is used as a serial data input.
48	SI				
49	CK				

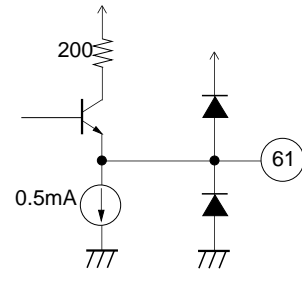
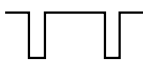

Pin No.	Symbol	Pin voltage		Equivalent circuit	Description
		DC	AC		
50	D.O.PULSE	High : 3.1V, Low : 0V input	—		Drop out pulse input. $V_{TH} = 2.05V$ If the drop out pulse is input, the signal prior to 1H is output for the Y system and the APC and ACC system errors are held for the C system.
51	APC FL	2.25V (typ.) during lock	—		Connects an APC external filter.
52	AFC FL	2.25V (typ.) during lock	—		Connects an AFC external filter.
53	EXT C IN	2.6V	(Chroma signal 314mVp-p input		During recording, the chroma signal is input. When the typical level is 75% color bar input, the input signal is 314mVp-p.
54	DCFB	2.25V (typ.) during lock	—		Connects a DC feedback external filter for a non-adjustment VCO.

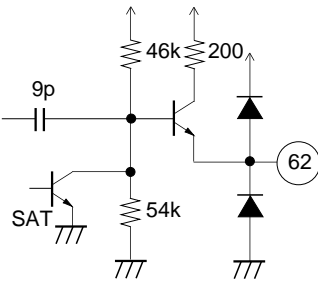
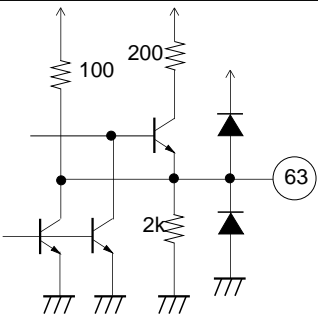
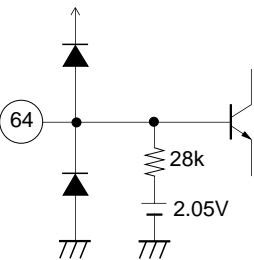
Pin No.	Symbol	Pin voltage		Equivalent circuit	Description
		DC	AC		
55	I REF	1.8V (when resistance connected)	—		External reference current source. Connect external resistance of 18kΩ to GND. Be careful concerning interference pin.
56	GND	0V	—		Main block GND.
57	XTAL IN	2.0V	260mVp-p (NTSC) during playback		Crystal oscillation reference input. Be careful concerning interference pin and the floating capacitance.
58	VREG	4.1V	—		4.1V regulator output.
59	XTAL OUT	3.1V	340mVp-p (NTSC) during playback		Crystal oscillation reference output. Connects the crystal between this pin and Pin 57.
60	CAM FSC SHP	Sharpness control range: 1.8V to Vcc	—		Subcarrier input during camera recording. 200mVp-p(min). Sharpness control during playback.

Pin No.	Symbol	Pin voltage		Equivalent circuit	Description
		DC	AC		
61	FSC OUT	2.2V	NTSC 600mVp-p PAL 450mVp-p 		Subcarrier output. This subcarrier is used for the CCD delay line clock frequency.
62	BF VCO	During BF output  High : 1.8V, Low : 0V Low during BF interval	550mVp-p during VCO output 		Burst flag and VCO OUT output for testing. When using this pin, connect 3.3kΩ resistance to GND. Serves as VCO output when mode TEST2 is High.
63	C OUT	2.0V	Chroma signal 314mVp-p output (during recording)		During recording, outputs chroma signal after Y/C separation or for chroma signal input from Pin 53. During playback, the playback chroma signal is output. During ACK, the output DC becomes 0V.
64	C IN	2.05V	Chroma signal 314mVp-p input		Inputs chroma signal to Y/C MIX circuit in the I/O block. During component signal recording or playback, this signal is Y/C mixed and is then output from V OUT.

**Electrical Characteristics**

( $V_{CC} = 4.75V$ ,  $T_a = 25^\circ C$ , see Electrical Characteristics Test Circuit and BUS DECODER Mode Condition Table.)  
 \* Start measurements after adjustments in accordance with the Precautions Concerning Measurements.

No.	Measurement item	Symbol	Input conditions			Control DC		SW set to ON	Mode conditions	Measurement point	Measurement method			Ratings		Unit
			Signal source	Amplitude	Frequency	Voltage source	Voltage				Min.	Typ.	Max.			
<b>&lt;Current consumption, reference bias source&gt;</b>																
1	Composite signal input Current consumption during recording	IREC1	—	—	—	—	—	A	I <sub>I</sub>		63	88	113		mA	
2	Separate signal input Current consumption during recording	IREC2	—	—	—	—	—	C	I <sub>I</sub>		55	78	100		mA	
3	Composite signal input Current consumption in power saving mode	IPS1	—	—	—	—	—	D	I <sub>I</sub>		20	30	40		mA	
4	Separate signal input Current consumption in power saving mode	IPS2	—	—	—	—	—	E	I <sub>I</sub>		35	53	70		mA	
5	Current consumption during playback	IPB	—	—	—	—	—	F	I <sub>I</sub>		68	94	120		mA	
6	Internal reference voltage source 1	VREG	—	—	—	—	—	A	P58	$V_{CC}=4.75V$ , voltage at Pin (58):VREG	3.90	4.13	4.36		V	
7	Internal reference voltage source 1 (VCC-)	VREG-	—	—	—	—	—	A	P58	$V_{CC}=4.5V$ , voltage at Pin (58):VREG1 $V_{REG}=V_{REG1}-V_{REG}$	-12	-1			mV	
8	Internal reference voltage source 1 (VCC+)	VREG+	—	—	—	—	—	A	P58	$V_{CC}=5.25V$ , voltage at Pin (58):VREG2 $V_{REG}=V_{REG2}-V_{REG}$		+1	+12		mV	
9	Internal reference voltage source 2	VG1	—	—	—	—	—	A	P11	Voltage at Pin (11)	1.95	2.08	2.21		V	
10	Reference current source	IREF	—	—	—	—	—	A	P55	$IREF=(\text{voltage at Pin (55)}/18k)$	94	100	106		$\mu A$	
<b>&lt;Y recording&gt;</b>																
11	SYNC AGC input Low level	VAGCL	e	SG30	—	—	—	B	P34	Measures the output SYNC level		143			mV	
12	SYNC AGC input High level	VAGCH	f		—	—	—					143			mV	
13	PEAK AGC	VAGCP	g		—	—	—					550			mV	

No.	Measurement item	Symbol	Input conditions			Control DC		SW set to ON	Mode conditions	Measurement point	Measurement method	Ratings			Unit	
			Signal source	Amplitude	Frequency	Voltage source	Voltage					Min.	Typ.	Max.		
14	For video AGC off characteristics	F101	d	SG30	Sine wave 357mVp-p	300kHz /5MHz	—	—	SW30	A	P34	Level ratio between 300kHz sine wave and 5MHz sine wave	-1.5	0	1.5	dB
15	For video AGC on	F102						B					-1.5	0	1.5	dB
16	300kHz gain for TRAP off	Gyc1	d	SG30	Sine wave 357mVp-p	300kHz	—	—	SW30	G	P14	I/O gain of 300kHz sine wave (Refer to output waveform measurement Nos. 14 and 15.)		-0.3		dB
17	300kHz gain for TRAP on	Gyc2				300kHz		C						-0.6		dB
18	fsc TRAP 3.58MHz gain	Gyc3				3.58MHz						Level ratio between 300kHz sine wave and 3.58MHz sine wave (Refer to output waveform measurement Nos. 14 and 15.)		-23	-14	dB
19	Hard clip amount	K <sub>H.C</sub>	b	SG5-1	500mVp-p	—	—	—	SW5-1	H	P39	Level ratio of this signal output with 500mVp-p input and with 647mVp-p input		115		%
20	White clip amount	K <sub>w.c</sub>	b	SG5-1	500mVp-p	—	—	—	SW5-1	H	P39			235		%
21	Dark clip amount	K <sub>d.c</sub>	c		647mVp-p	—	—	—	—	—	—			95		%
22	-3dB 500kHz	FE11	a	SG5-2	-3dB (354mVp-p)	10kHz/ 500kHz	—	—	SW5-1	H	P39	Measures level ratio of each output frequency component. (These emphasis characteristics include white/dark clipping.)	10.7		11.7	dB
23	-3dB 2MHz	FE12				10kHz/ 2MHz		SW5-3					11.8		15.8	dB
24	-10dB 2MHz	FE13			-10dB (158mVp-p)								15.0		19.0	dB
25	-20dB 2MHz	FE14			-20dB (50mVp-p)								19.5		25.5	dB

No.	Measurement item	Symbol	Input conditions			Control DC		SW set to ON	Mode conditions	Measurement point	Measurement method	Ratings		Unit	
			Signal source	Amplitude	Frequency	Voltage source	Voltage					Min.	Typ.		Max.
26	Output level	V <sub>MOD</sub>	—	—	—	—	—	A	P39	<p>Signal level with 4.2MHz output</p>	440	500	560	mVp-p	
27	Secondary distortion	D <sub>MOD</sub>	—	—	—	—	—	—	—	<p>Ratio to secondary higher harmonic components with 4.2M output V (8.4MHz)/V (4.2MHz)</p>	—	-34	—	dB	
28	Carrier control minimum frequency (L)	f <sub>CL</sub> MIN	—	—	—	V44	1.8V	—	—	Measures the output frequency	—	3	4.2	MHz	
29	Carrier control maximum frequency (L)	f <sub>CL</sub> MAX	—	—	—	V44	4.75V	—	—	Measures the output frequency	4.2	5.2	—	MHz	
30	Deviation control minimum frequency (L)	f <sub>DL</sub> MIN	—	—	—	V5-1	V <sub>G1</sub> +0.5V	A	—	Makes initial setting of V44, applies test 9 measurement V <sub>G1</sub> +0.5V to V5-1 and then measures the output frequency.	—	5.0	5.4	MHz	
31	Deviation control maximum frequency (L)	f <sub>DL</sub> MAX	—	—	—	V43	1.8V	—	—	Measures the output frequency	5.4	5.9	—	MHz	
32	Linearity (L)	L <sub>MODL</sub>	—	—	—	V5-1	V <sub>G1</sub>	A	P39	Makes initial setting of V44, applies test 9 measurement V <sub>G1</sub> . V <sub>G1</sub> +0.25V and V <sub>G1</sub> +0.5V to V5-1 and then calculates the following equation using the output frequency.	0.9	1.0	1.1	—	
<Y playback>															
33	PB Y comb filter ATT level	K <sub>0</sub>	a	SG3	300kHz	—	—	SW3-1	J1	P14	Measures the I/O gain under all mode conditions.	-7.8	-4.8	-1.8	dB
34		K <sub>1</sub>						SW4	J2			-9.3	-6.3	-3.3	dB
35		K <sub>2</sub>							J3			-21	-18	-15	dB
36		K <sub>3</sub>							J4				-32		dB
37	HHS canceler	V <sub>DEHHS</sub>	—	—	—	—	—	SW46-1 ON/OFF	F	P23	DC level difference at P23 (Pin 23) DL IN1) when SW46-1 is turned on and off		1.6		mV
38	PB sharpness characteristics	EDIT	a	SG3	300kHz/2.15MHz	—	—	SW3-1	K	P14	Measures the level ratio of P14 (Pin 14) Y COMB OUT) output between 300kHz input and 2.15MHz input.		-1.0		dB
39		MIN				V60	1.8V	SW4	F				-10		dB
40		MAX				V60	4.75V						7		dB



No.	Measurement item	Symbol	Input conditions			Control DC		SW set to ON	Mode conditions	Measurement point	Measurement method	Ratings				
			Signal source	Amplitude	Frequency	Voltage source	Voltage					Min.	Typ.	Max.	Unit	
54	300kHz gain	GLPF11	SG41	200mVp-p	300kHz	—	SW41	F	P7	Calculates the equations at left using the output level of P7 (Pin ⑦ DEMOD OUT) for each input frequency.  Refer to Detailed Explanation of Measurement Method (1) for compensation values GC1 and GC2. The amplitude frequency indicated for the input conditions is the value of SG54 in SG41.	-1.5	0	1.5	dB		
55	2.5MHz frequency characteristic	FLPF12			2.5MHz						-1.5	0	1.5	dB		
56	6.12MHz frequency characteristic	FLPF13			6.12MHz							-38			dB	
57	300kHz gain	GLPF21			300kHz			M			-1.5	0	1.5	dB		
58	4.0MHz frequency characteristic	FLPF22			4.0MHz						-0.5	1.0	2.0	dB		
59	7.8MHz frequency characteristic	FLPF23			7.8MHz							-16	-10		dB	
<Y recording/playback>																
60	DSDS (Date display system)	VOB	SG26	—	—	—	SW26	B	P34	Refer to Detailed Explanation of Measurement Method (2).  P24 ( ㉔ COMP SYNC)  P34 ( ㉔ YOUT)	-10	15	40	mV		
61		VOW	SG30				SW30						340			mV
62		JOG VD	ΔJOGVD	SG31				SW31						10	35	mV
63	Composite sync pulse	High level	h	—	—	—	SW30	B	P24	Measures the DC level difference with the pedestal level.  Measures the DC level difference with the sync tip level.	2.3	2.5	2.7	V		
64		Low level	Vcs-L										0.03	0.2		V
65		Pulse width	Wcs											4.5		μsec
66		Delay	Dcs										0.1	0.35	0.7	μsec
67	Video buffer	Amplifier gain	d	Sine wave	300kHz	—	SW32	A	P36	Measures the I/O gain for a 300kHz sine wave overlapping the Y signal.  Measures level ratio for a 300kHz sine wave and 5MHz sine wave overlapping the Y signal.	5.5	6.0	6.5	dB		
68		5MHz frequency characteristic	Fbuff		357mVp-p	300kHz / 5MHz								0		dB

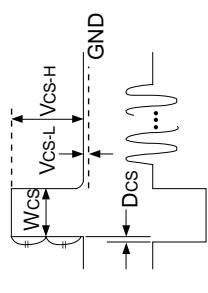



No.	Measurement item	Symbol	Input conditions			Control DC		Mode conditions	Measurement point	Measurement method	Ratings		Unit	
			Signal source	Amplitude	Frequency	Voltage source	Voltage				Min.	Typ.		Max.
83	REC C RF LEVEL	VRECC	i	SG53	VC=314mVp-p	3.58MHz	—	—	P8	Measures the output level of the chroma interval. VRECC	210	300	420	mVp-p
84	REC Chroma band1 (-750kHz)	FRECC1				2.83MHz		Q		Measures the ratio between VRECC and the output level for the chroma interval.		-40		dB
85	REC Chroma band2 (-300kHz)	FRECC2				3.28MHz				The output frequencies of 3.58MHz + ΔfkHz are converted to 743kHz-ΔfkHz for frequency conversion.		-2.0		dB
86	REC Chroma band3 (+300kHz)	FRECC3				3.88MHz						2.5		dB
87	REC Chroma band4 (+650kHz)	FRECC4				4.23MHz						-1.0		dB
88	Rec APC Pull-in Range (NTSC)	fAPCRN+	a	SG53	143mVp-p	3.58MHz +ΔfHz	—	Q	P61	Upper input frequency pulled in within 2 seconds by the SG53 input frequency (3.58MHz+1kHz).	230			Hz
89	Lower pull-in range	fAPCRN-				3.58MHz -ΔfHz				Lower input frequency pulled in within 2 seconds by the SG53 input frequency (3.58MHz-3kHz).			-230	Hz
90	Rec APC Pull-in Range (PAL)	fAPCRP+	j			4.43MHz +ΔfHz		R		Upper input frequency pulled in within 2 seconds by the SG53 input frequency (4.43MHz + 1kHz).	200			Hz
91	Lower pull-in range	fAPCRP-				4.43MHz -ΔfHz				Lower input frequency pulled in within 2 seconds by the SG53 input frequency (4.43MHz-3kHz).			-200	Hz
92	Rec AFC Pull-in Range (NTSC)	fAFCN+	l	SG24	—	16.206kHz (+3%)	—	S1→S2	P62	Measures the output frequency one second later after switching the mode conditions.		6125979		Hz
93	Lower pull-in range	fAFCN-				15.262kHz (-3%)		S24-2				5769126		Hz
94	Upper pull-in range	fAFCP+				16.094kHz (+3%)		S3→S4				6035156		Hz
95	Lower pull-in range	fAFCP-				15.156kHz (-3%)						5683594		Hz

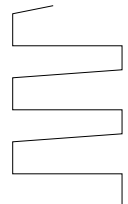

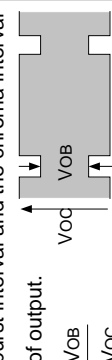

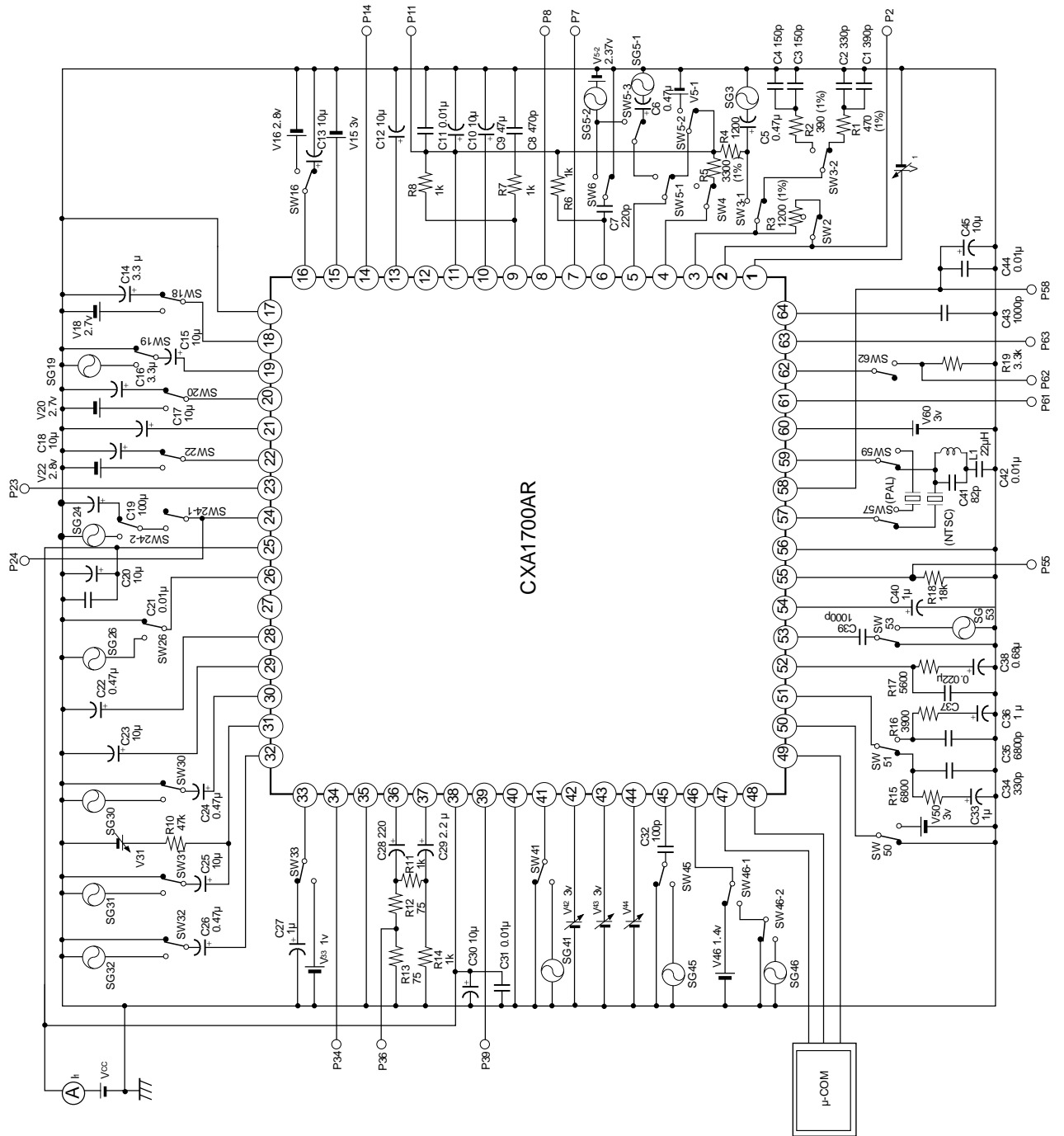

No.	Measurement item	Symbol	Input conditions			Control DC		SW set to ON	Mode conditions	Measurement point	Measurement method			Ratings		
			Signal source	Amplitude	Frequency	Voltage source	Voltage				Min.	Typ.	Max.	Min.	Typ.	Max.
<C playback>																
96	PB C OUT level	V <sub>PBC0</sub>	n	SG45	VC= 200mVp-p	743kHz	—	—	P63	Measures the output level of the chroma interval. V <sub>PBC0</sub> .	130	200	300	mVp-p		
		F <sub>PBC1</sub>				100kHz			T		Measures the ratio between V <sub>PBC0</sub> and the output level of the chroma interval. The output frequencies of 743kHz + Δf kHz are converted to 3.58MHz-Δf kHz for frequency conversion.		-2.4		dB	
		F <sub>PBC2</sub>				443kHz							-0.5		dB	
		F <sub>PBC3</sub>				1043kHz								-2.3		dB
		F <sub>PBC4</sub>				1.9MHz								-40		dB
97	PB C OUT Level	ΔG <sub>CH12</sub>	a/k	SG45	200mVp-p	743kHz	—	—	P63	Refer to Detailed Explanation of Measurement Method (3). Measures the gain difference between channels.	-0.5	0	0.5	dB		
		ΔG <sub>CH13</sub>				50Hz			T			-0.5	0	0.5	dB	
		ΔG <sub>CH14</sub>	o	SG46	1.4Vo-p								-0.5	0	0.5	dB
		PB ACC gain difference between channels														
101	Gain difference between channels 1-2	F <sub>ACC</sub>	m	SG53	—	—	—	—	P8	Refer to Detailed Explanation of Measurement Method (4).		0.6	3.0	dB		
		High-speed ACC compression ratio														
102	Gain difference between channels 1-3	B <sub>DE</sub>	a	SG45	200mVp-p	743kHz	—	—	P63	Measures the level ratio between the burst interval and the chroma interval of output. 	-5.5	-4.5	-3.5	dB		
		Burst de-emphasis level														
103	Frequency deviation	Δf <sub>XON</sub>	—	—	—	—	—	—	P61	Difference between output frequency and f <sub>SCN</sub> =3579545Hz. Δf <sub>XON</sub> = f <sub>XON</sub> - f <sub>SCN</sub>	-50		50	Hz		
		Output level	V <sub>XON</sub>									450	600	750	mVp-p	
		Secondary distortion	HD <sub>2XON</sub>										-45	-25	dB	
104	Secondary distortion	Ratio with secondary higher harmonic component. V (7.16MHz)/V (3.58MHz)														

No.	Measurement item	Symbol	Input conditions			Control DC		Mode conditions	Meas-urement point	Measurement method	Ratings		Unit	
			Signal source	Amplitude	Frequency	Voltage source	Voltage				Min.	Typ.		Max
109	Frequency deviation	$\Delta f_{XOP}$	—	—	—	—	—	F	P61	Difference between output frequency and $f_{SCP} = 4433619\text{Hz}$ . $\Delta f_{XOP} = f_{XOP} - f_{SCP}$ Measures the output level. Ratio with secondary higher harmonic component. $V(8.86\text{MHz})/V(4.43\text{MHz})$	-50	50	Hz	
			—	—	—	—	—	—			—	—	—	—
110	Output level	$V_{XOP}$	—	—	—	—	—	—	—	—	—	—	mVp-p	
111	Secondary distortion	HD2XOP	—	—	—	—	—	—	—	—	—	—	dB	
112	Upper pull-in range	$f_{APCN+}$	a	SG45	200mVp-p	765.747kHz	—	V1→V2	P62	Measures the output frequency one second later after switching the mode conditions.	6125979	—	Hz	
			l	SG24	—	16.206kHz	—	—			—	—	—	—
113	Lower pull-in range	$f_{APCN-}$	a	SG45	200mVp-p	721.141kHz	—	—	—	—	5769126	—	Hz	
			l	SG24	—	15.262kHz	—	—			—	—	—	—
114	Upper pull-in range	$f_{APCP+}$	a	SG45	200mVp-p	754.395kHz	—	V3→V4	—	—	6035156	—	Hz	
			l	SG24	—	16.094kHz	—	—			—	—	—	—
115	Lower pull-in range	$f_{APCP-}$	a	SG45	200mVp-p	710.449kHz	—	—	—	—	5683594	—	Hz	
			l	SG24	—	15.156kHz	—	—			—	—	—	—
116	Delay	Tdbf	b	SG5-1	—	—	—	F	P62		3.5	4.1	4.7	µsec
			—	—	—	—	—	—			—	—	—	—
117	Pulse width	Wdbf	—	—	—	—	—	—	—	—	—	—	µsec	

Electrical Characteristics Test Circuit

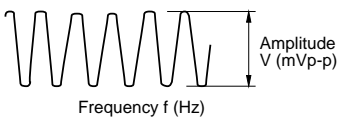
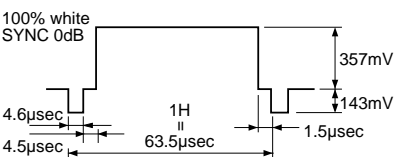

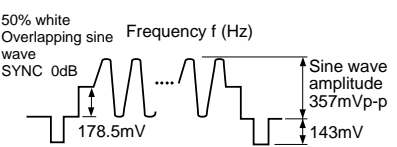
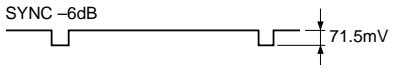
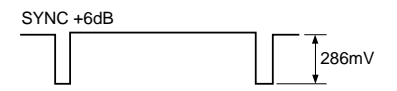
Input signal

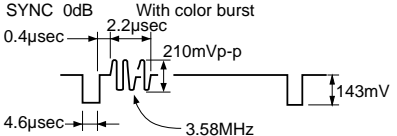
Signal	Input signal waveform	Signal source
a		SG3 SG5-2 SG19 SG41 SG45 SG53
b		SG5-1
c		SG5-1
d		SG30 SG32
e		SG30
f		SG30
g		SG30
h		SG30

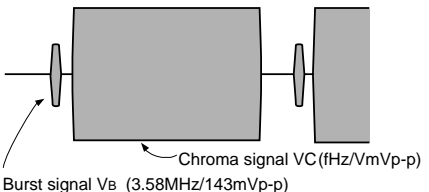
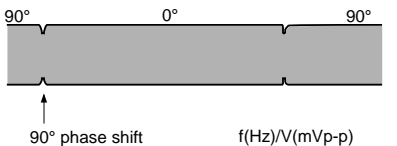
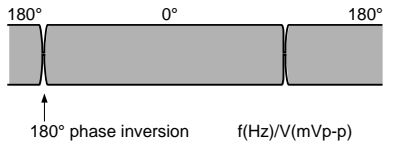
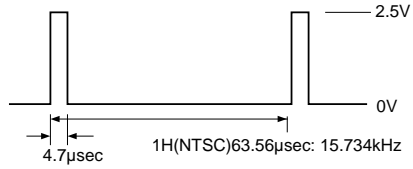
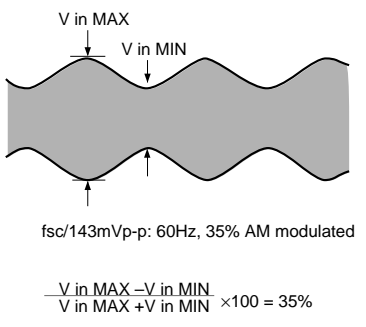
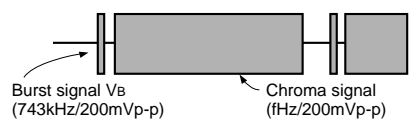
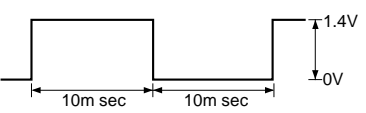
Signal	Input signal waveform	Signal source
i		SG53
j		SG53
k		SG45
l		SG24
m		SG53
n		SG45
o		SG46

**Detailed Explanation of Measurement Method**

(1) DEMOD LPF frequency characteristics measurement

Using the CXA1207A as a modulator, the configuration for SG41 is shown below.

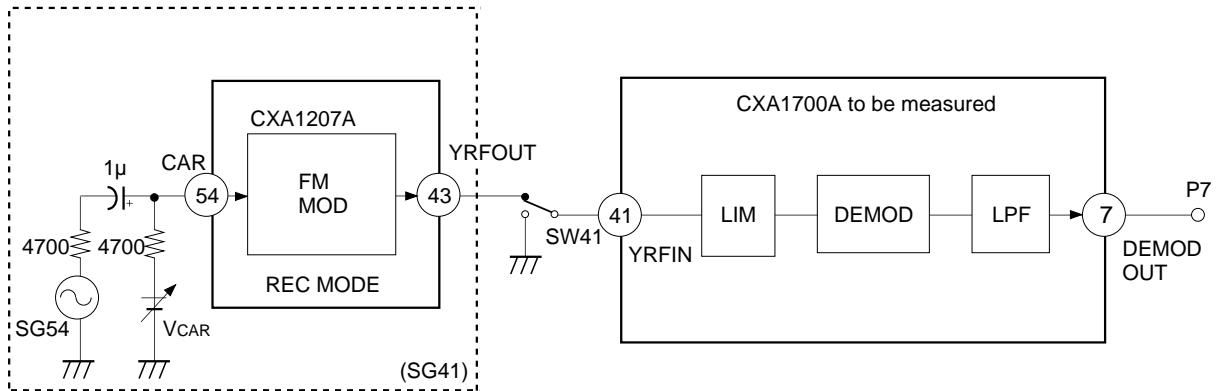

First, without inputting SG54, adjust VCAR so that the Y RF OUT (Pin 43) output frequency of the CXA1207A is 5MHz. Use VCARO for the VCAR voltage. Next, apply VCARO + 500mV, measure the Y RF OUT (Pin 43) output frequency fo of the CXA1207A, and then calculate the MOD gain using the following equation.

$$G_{MOD} = \frac{f_o \text{ (MHz)} - 5 \text{ (MHz)}}{500 \text{ (mV)}}$$

The compensation values are derived from GMOD and from GDEM0D1 and GDEM0D2 of measurement Nos. 48 and 50.

Standard mode compensation value :  $G_{C1} = 20\log [G_{MOD} \text{ (MHz/mV)} \times G_{DEM0D1} \text{ (mV/MHz)}]$

Hi-8 mode compensation value :  $G_{C2} = 20\log [G_{MOD} \text{ (MHz/mV)} \times G_{DEM0D2} \text{ (mV/MHz)}]$

Next, in order to set the SG41 carrier frequency, adjust VCAR so that the Y RF OUT (Pin 43) output of the CXA1207A in standard mode is 4.8MHz and in Hi-8 mode is 6.7MHz.

In the above state, measure the I/O gain for the SG54 (200mVp-p/300kHz) input and P7 (Pin 7 DEMOD OUT), with the gain for standard mode being GLPF10 and for Hi-8 mode GLPF20.

Using these measured values and compensation values, the low frequency gain for DEMOD LPF is determined using the following equations:

Standard mode :  $GLPF11 = GLPF10 - G_{C1} \text{ (dB)}$

Hi-8 mode :  $GLPF21 = GLPF20 - G_{C2} \text{ (dB)}$

(2) DDS measurement

When a pulse with the following timing is input, the output from P34 (Pin 34 Y OUT) becomes as shown below; measures each DC differential.

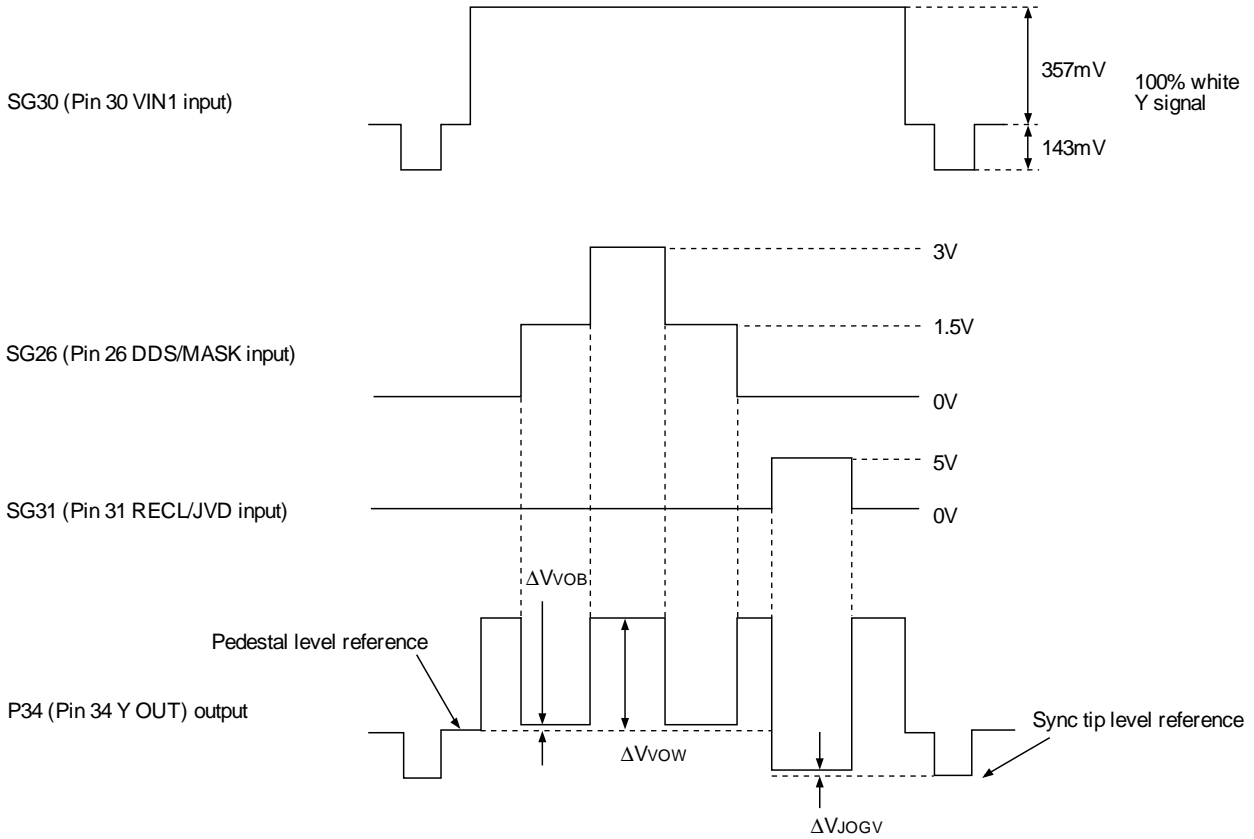

(3) Measurement of gain difference between PB ACC channels

The ACC amplifier in the CXA1700 has a built-in 4-channel time constants, and those time constants can be switched by SWP (Pin 46) input. In addition, in NTSC playback chroma signal processing, PI return occurs in the SWP (Pin 46) input for Low interval. In this measurement, the signal k, that is phase-inverted each 1H, is input to PBC IN (Pin 45) for the Low interval of SWP; the continuous wave of the signal is input for the High interval of SWP.

In this case, measure each channel level V1, V2, V3, and V4 of output P63 (Pin 63 C OUT) and calculate the gain difference between channels using the following equations:

$$\Delta G_{CH12} = \frac{V_2}{V_1}$$

$$\Delta G_{CH13} = \frac{V_3}{V_1}$$

$$\Delta G_{CH14} = \frac{V_4}{V_1}$$

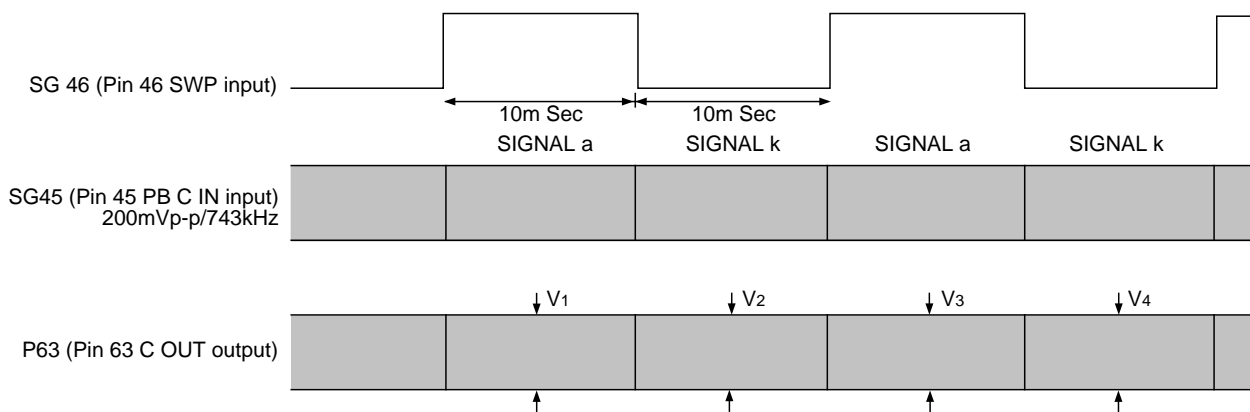
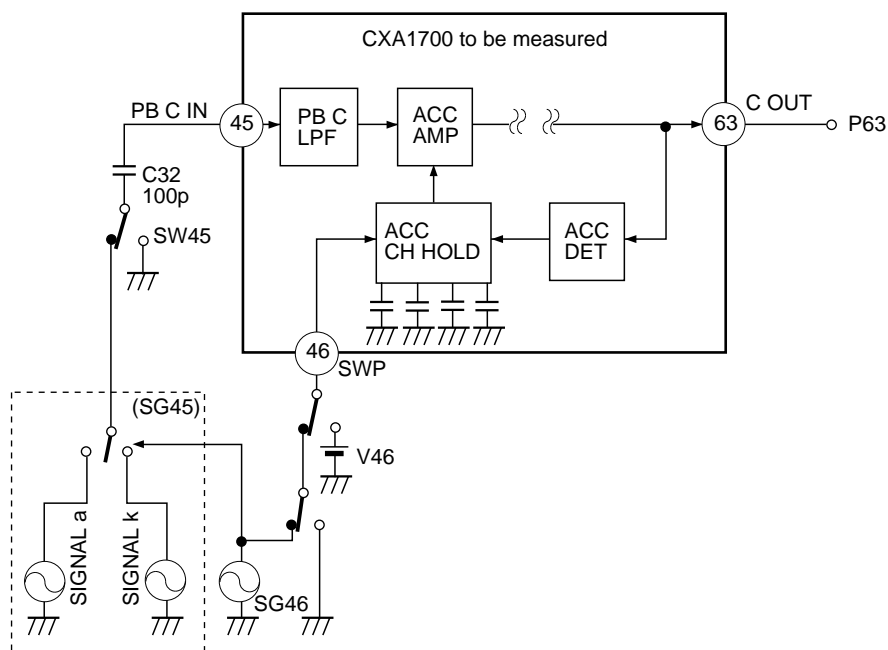

(4) High-speed ACC compression ratio measurement

Measure the high-speed ACC compression ratio in JOG mode by inputting a modulation wave as shown below.

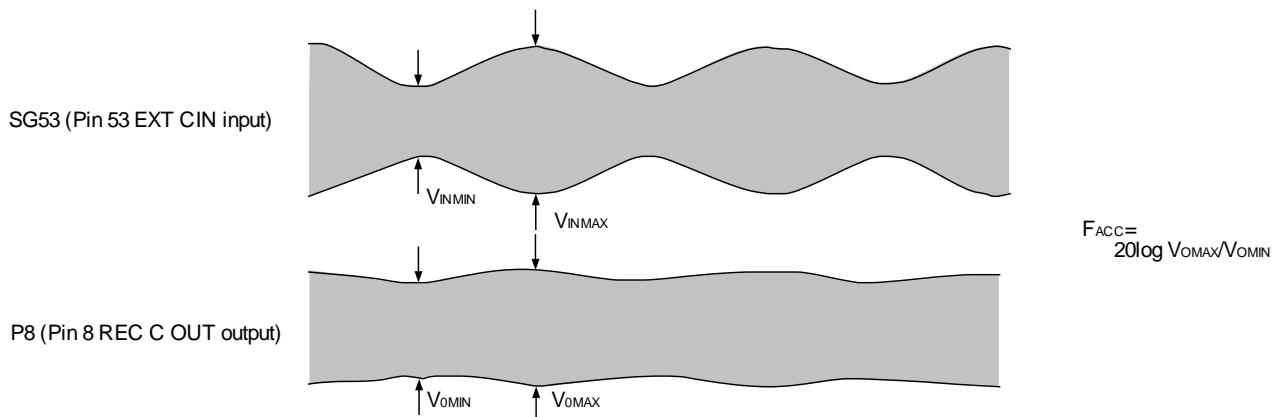

$$F_{ACC} = 20 \log V_{OMAX} / V_{OMIN}$$

(Blanks indicate Low)

BUS DECODER Condition Table for Measuring Electrical Characteristics

Mode condition	TEST2	TEST1	SYNC OFF	CORRE H	SHP THROU	ACK OFF	FBC L2	C SEL	DC2	DC1	C MUTE OFF	PAL	CAMREC	PS	Yd	NCLP2	NCLP1	NCL2	NCL1	CFL2	CFL1	E	FBC L1	JOG	EDIT	CCIR	WCCD	MUTE	Video AGC	INSEL	S	PB	Description			
A																																Composite REC 9Video AGC OFF)				
B																																Composite REC (Video AGC ON)				
C																																Separate REC				
D																																Composite REC power save				
E																																Separate REC power save				
F																																Normal PB				
G																																Y comb OUT f characteristics				
H																																Y pre-emphasis characteristics				
J1																																	PB Y comb filter ATT level			
J2																																				
J3																																				
J4																																				
K																																				
L1																																				
L2																																				
L3																																				
L4																																				
L5																																				
M																																				
N																																				
O																																				
P																																				
Q																																				
R																																				
S1																																				
S2																																				
S3																																				
S4																																				
T																																				
U																																				
V1																																				
V2																																				
V3																																				
V4																																				

**Precautions Concerning Measurements (Refer to Electrical Characteristics Test Circuit).**

1. Start measurements after making the following adjustments.
  - 1) Recording level (video AGC) adjustment  
With the SW conditions (SW30: on) and the mode conditions: B the same as for measurement Nos. 11 to 13, adjust V31 so that the P34 (Pin 34 Y OUT) output is 500mVp-p when signal b (100% white, 500mVp-p Y signal) is input from SG30.
  - 2) CAR adjustment (normal)  
With the SW conditions at the initial settings and the mode conditions: A, adjust V44 so that the frequency of the P39 (Pin 39 Y RF OUT) output is 4.2MHz.
  - 3) Chroma emphasis adjustment  
With the SW conditions (SW24-1, SW24-2, SW53: on), and the mode conditions: P the same as for measurement Nos. 75 to 80, adjust V1 so that the signal level for the chroma interval of the P8 (Pin 8 REC C OUT) output is at a minimum when signal I is input from SG24 and signal i is input from SG53. (chroma interval 3.58MHz/99.3mVp-p)
2. Although no input conditions are indicated for C measurement Nos. 71 to 117, signal I is input from SG24. Unless otherwise specified in the input conditions, the frequency for SG24 is 15.734kHz.
3. Note that in regards to the measurements shown below, the characteristics change depending on the floating capacitance.
  - 1) White/dark clipping level
  - 2) Pre-emphasis characteristics
  - 3) REC APC pull-in range
4. When taking measurements, use metal film resistors with an allowable deviation of 1% for R1, R2, R3, and R5, and use temperature compensation CH types for C1, C2, C3, and C4.

**BUS DECODER**

1) Data contents

bit No.	MODE	CONTENT	bit No.	MODE	CONTENT									
1	TEST2	H TEST2 1) Outputs VCO OUT signal to BF VCO (Pin 62). 2) Outputs white/dark-clipped Y signal to Y REF OUT (Pin 39).	9	DC 2 (Dark Clip)	The dark clipping level is switched as shown below. (when white clipping is 235% and WDC (Pin 27) is left open)									
		L Normal												
2	TEST1	H TEST1 mode 1) Cuts APC loop and inputs signal from CAM FSC SHP (Pin 60) to VCO OUT. 2) During REC, outputs burst emphasis output to REC C OUT (Pin 8). 3) For the PB chroma feedback comb measurement, inputs signal from EXT C IN (pin 53) to the comb block without passing it through PB CONV.	10	DC 1	<table border="1" style="margin-left: auto; margin-right: auto;"> <tr> <td style="text-align: center;">DC 1 DC 2</td> <td style="text-align: center;">High</td> <td style="text-align: center;">Low</td> </tr> <tr> <td style="text-align: center;">High</td> <td style="text-align: center;">85</td> <td style="text-align: center;">95</td> </tr> <tr> <td style="text-align: center;">Low</td> <td style="text-align: center;">105</td> <td style="text-align: center;">115</td> </tr> </table> <p style="text-align: center;">(UNIT: %)</p> <p>Switches the amount of the dark clipping level offset to the white clipping level, which can be varied in steps of 10%.</p>	DC 1 DC 2	High	Low	High	85	95	Low	105	115
		DC 1 DC 2				High	Low							
High	85	95												
Low	105	115												
3	SYNC OFF	H Sync Separation does not operate. (External input to COMP SYNC (Pin 24) is possible).	11	C MUTE  OFF	H Disables MUTE for the chroma signal by the MASK signal.									
		L Normal			L Mutes the chroma signal by the MASK signal.									
4	CORRE H	H Fixes the correlation pulse High so that there is always correlation.	12	PAL	H PAL (chroma function)									
		L Detects correlation.			L NTSC									
5	SHP THRU	H Sharpness block through (does not pass through fsc Trap, Sharpness, LPF and EQ)	13	CAM REC	H During recording, inputs fsc, locked to burst, from CAM FSC SHP (Pin 60) without performing APC with the input chroma signal, and then performs frequency conversion using this fsc. Recordable time can be reduced to 0.2 seconds or less from power saving mode with separate input.									
		L Normal			L Normal									
6	ACK OFF	H ACK SW does not operate according to ACK DET; always fixed to color mode.	14	PS (Power Save)	H 1) $\bar{S}$ •PS (31.S=Low) Changes to power saving mode with composite input. Power consumption: 140mW (Vcc=4.75V) 2) S•PS (31.S=High) Changes to power saving mode with separate input. Power consumption:250mW (Vcc=4.75V)									
		L ACK operation is performed according to ACK DET.			L Normal									
7	F.B.C. L2 (Feed Back Comb)	Switches the feedback amount of the FBC (feedback comb). * Refer to Table 1.	8	C SEL	H During recording, the signal input to EXT C IN (Pin 53) is input directly to the ACC amplifier.									
L Normal	L Normal													
8	C SEL	L Normal	15	Yd	H Performs Yd playback during playback.									
					L Normal									

bit No.	MODE	CONTENT	bit No.	MODE	CONTENT																
16	NCLP2	During playback, switches the noise canceler characteristics.	29	Video AGC	H	Video AGC on															
17	NCLP1				L	Video AGC off															
18	NCL2		30	INSEL (INput SElection)	H	Selects VIN2 (Pin 28) input.															
19	NCL1				L	Selects VIN1 (Pin 30) input.															
20	CFL2	The typical value of PB Y comb filter depth is switched as shown below. (Low frequency: insignificant level input)	31	S	H	For separate signals during recording.															
21	CFL1				L	For composite signals during recording.															
			32	PB	H	Playback mode															
L	Recording mode																				
		<table border="1"> <tr> <td></td> <td>CFL1</td> <td>High</td> <td>Low</td> </tr> <tr> <td>CFL2</td> <td></td> <td></td> <td></td> </tr> <tr> <td>High</td> <td></td> <td>-10dB</td> <td>-6dB</td> </tr> <tr> <td>Low</td> <td></td> <td>-1.5dB</td> <td>0dB</td> </tr> </table>		CFL1	High	Low	CFL2				High		-10dB	-6dB	Low		-1.5dB	0dB			
	CFL1	High	Low																		
CFL2																					
High		-10dB	-6dB																		
Low		-1.5dB	0dB																		
22	E	H	Hi-8 mode																		
		L	Standard mode																		
23	F.B.C. L1	Switches the feedback amount of the chroma feedback comb. * Refer to Table 1.																			
24	JOG	H	1) High-speed ACC mode. 2) During playback, does not perform dropout compensation.																		
		L	Normal																		
25	EDIT	H	EDIT mode 1) During recording, the chroma signal is Y/C separated by the BPF only without passing through the comb filter. 2) During playback, cuts the feedback loop of chroma feedback comb. 3) During playback, makes the sharpness characteristics flat.																		
		L	Normal																		
26	CCIR	H	For fsc = 4.43MHz																		
		L	For fsc = 3.58MHz																		
27	W CCD	Fix to Low.																			
28	MUTE	H	1) Mutes the Y and chroma signals. 2) Discharges the charge in the external clamp capacitance for VIN1 (Pin 30) and VIN2 (Pin 28) and in the external capacitance for AGC TC1 (Pin 29).																		
		L	Normal																		

Table 1. Chroma Feedback Comb Loop Gain

		F.B.CL1	
		Low	High
F.B.C	Low	0dB	+1.9dB
	L2	High	+4.8dB

2) Timing chart

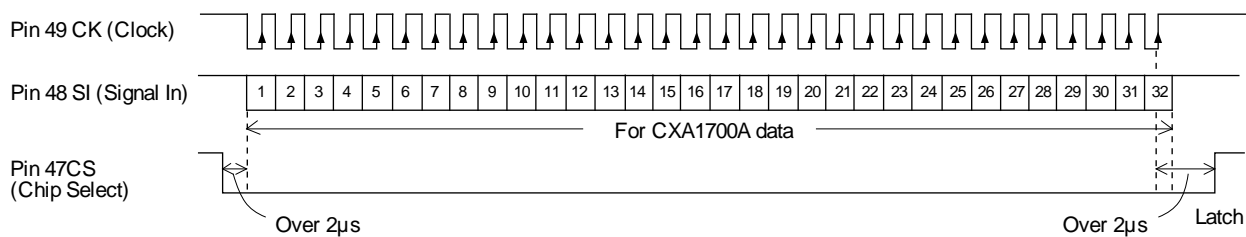

3) Input conditions

Item	Symbol	Min.	Typ.	Max.	Unit
Input high level for Pins 47, 48, and 49	V <sub>B-H</sub>	2.0			V
Input low level for Pins 47, 48, and 49	V <sub>B-L</sub>			1.0	V
Clock frequency	f <sub>CK</sub>			1.3	MHz
Setup time	t <sub>SU</sub>	400			nsec
Hold tie	t <sub>HLD</sub>	400			nsec
CS fall time to SI start time	t <sub>1</sub>	2			µsec
Final CK rise time to CS rise time	t <sub>2</sub>	2			µsec

BUS DECODER Mode Condition Table (NTSC)

				TEST2	TEST1	SYNC OFF	CORRE H	SHP THROU	ACK OFF	FBC L2	C SEL	DC2	DC1	C MUTE OFF	PAL	CAMREC	PS	Yd	NCLP2	
CAMERA	STAND-BY		Standard	L	L	L	L		L	*	L			L	L	H	H	L	*	
	REC		Standard	L	L	L	L		L	*	L			L	L	H	L	L	*	
	EDIT SEARCH		Standard	L	L	L	L		L	*	L	*	*	L	L	L	L	L		
VTR	REC	S	Standard	L	L	L	L		L	*	L			L	L	L	L	L	*	
		RCA	Standard	L	L	L	L		L	*	L			L	L	L	L	L	*	
	PB	Normal PB	Hi-8	SP	L	L	L	L		L		*	*	*	L	L	L	L	L	
			LP	L	L	L	L		L		*	*	*	L	L	L	L	L		
		Standard	SP	L	L	L	L		L		*	*	*	L	L	L	L	L		
		LP	L	L	L	L		L		*	*	*	L	L	L	L	L	L		
EDIT	Hi-8	SP	L	L	L	L		L	*	*	*	*	*	L	L	L	L	L		
	LP	L	L	L	L		L		*	*	*	*	*	L	L	L	L	L		
Standard	SP	L	L	L	L		L		*	*	*	*	*	L	L	L	L	L		
LP	L	L	L	L		L		*	*	*	*	*	*	L	L	L	L	L		

Note Don't care "\*". In addition, select for the blank SHP THRU column based on the system configuration; for other blanks according to the characteristics.

				NCLP1	NCL2	NCL1	CFL2	CFL1	E	FBCL1	JOG	EDIT	CCIR	WCCD	MUTE	Video AGC	INSEL	S	PB	
CAMERA	STAND-BY		Standard	*	*	*	*	*	L	*	L	L	L	L	L	H	H	H	L	
	REC		Standard	*	*	*	*	*	L	*	L	L	L	L	L	H	H	H	L	
	EDIT SEARCH		Standard							L	*	H	H	L	L	L	*	*	*	H
VTR	REC	S	Standard	*	*	*	*	*	L	*	L	L	L	L	L	H	H	H	L	
		RCA	Standard	*	*	*	*	*	L	*	L	L	L	L	L	H	L	L	L	
	PB	Normal PB	Hi-8	SP						H		L	L	L	L	L	*	*	*	H
			LP						H		L	L	L	L	L	L	*	*	*	H
		Standard	SP						L		L	L	L	L	L	L	*	*	*	H
		LP							L		L	L	L	L	L	L	*	*	*	H
EDIT	Hi-8	SP						H	*	L	H	L	L	L	L	*	*	*	H	
	LP							H	*	L	H	L	L	L	L	*	*	*	H	
Standard	SP							L	*	L	H	L	L	L	L	*	*	*	H	
LP								L	*	L	H	L	L	L	L	*	*	*	H	

**Description of Operation**

- Signal path during composite recording  
 Composite signals input from VIN1 (Pin 30) and VIN2 (Pin 28) are selected by mode INSEL, passed through the VIDEO AGC, and Y/C separated by the comb filter. The Y signal is output to Y COMB OUT (Pin 14). Next, level adjustment is performed externally and then the signal is input to EMPH IN (Pin 5), after which hard clipping, emphasis, white/dark clipping, and FM modulation are performed and then the signal is output from Y RF OUT (Pin 39). In addition, the Y OUT (Pin 39) signal is input to Y IN (Pin 32), and then the monitor signal is output from VIDEO OUT (Pin 36).  
 On the other hand, Y/C-separated C signal passes through the BPF and then along with being output to C OUT (Pin 63), the signal is also passed through ACC, chroma emphasis, and burst emphasis, low frequency converted, is passed through a LPF and then output from REC C OUT (Pin 8).

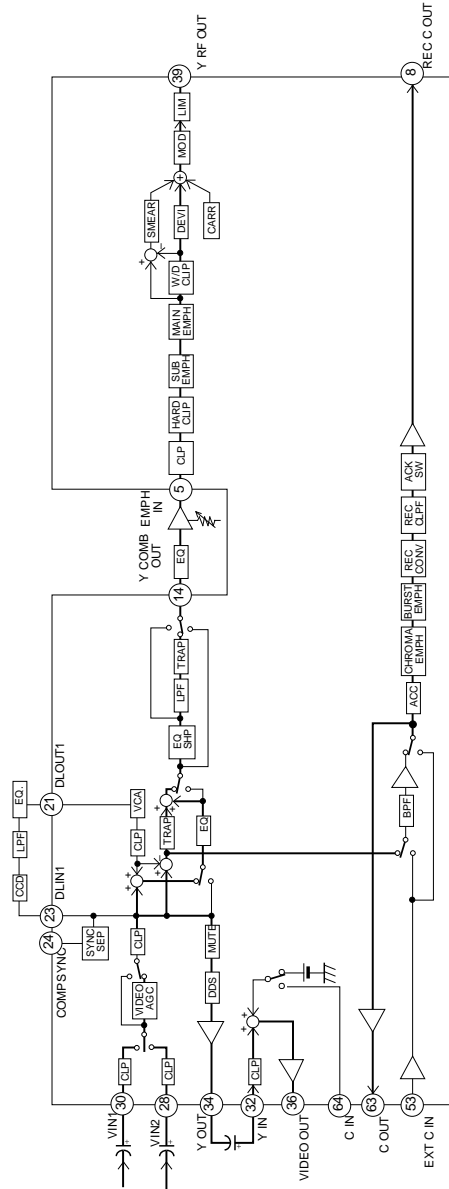

Pin No.	28	30	34	32	23	21	36	14	5	39	63	8
Signal waveform												
	0.5Vp-p	0.5Vp-p	2.0Vp-p	0.5Vp-p	0.5Vp-p	0.5Vp-p	0.5Vp-p	0.5Vp-p	0.5Vp-p	0.32Vp-p	0.32Vp-p	0.3Vp-p

2. Signal path during playback

The playback Y RF signal, after having passed through RF AGC and a soft limiter, is input to Y RF IN (Pin 41). After FM demodulation, the signal passes through the LPF and is then output from DEMOD OUT (Pin 7). After the waveform is formed and the level is adjusted by an external EQ and peaking amplifier, the signal is input to DE EMPH IN (Pin 10), after which clipping compensation, de-emphasis and HHS cancellation are performed. Next, cross talk cancellation is performed by a comb filter and then the signal is output from Y COMB OUT (Pin 14). After the waveform is formed and the level is adjusted by an external EQ (LPF) and peaking amplifier, the signal is input to 5 EMPH IN, where it passes through a noise canceler and is then output from Y OUT (Pin 34).

On the other hand, the playback RF signal, after passing through AFM and ATF TRAP, is input to PBC IN (Pin 45), after which the low-frequency C signal is separated by the PBC LPF. Next, the playback C signal, which has undergone level control by the ACC and frequency conversion by PB CONV and PBC BPF, is subjected to cross talk cancellation by the comb filter, and then after undergoing burst de-emphasis and chroma de-emphasis, the signal is output from C OUT (Pin 63).

By inputting the playback Y signal (Y OUT (Pin 34) output) to Y IN (Pin 32) and the playback C signal (C OUT (Pin 63) output) to C IN (Pin 64), the Y/C mixed signal is output from VIDEO OUT (Pin 36).

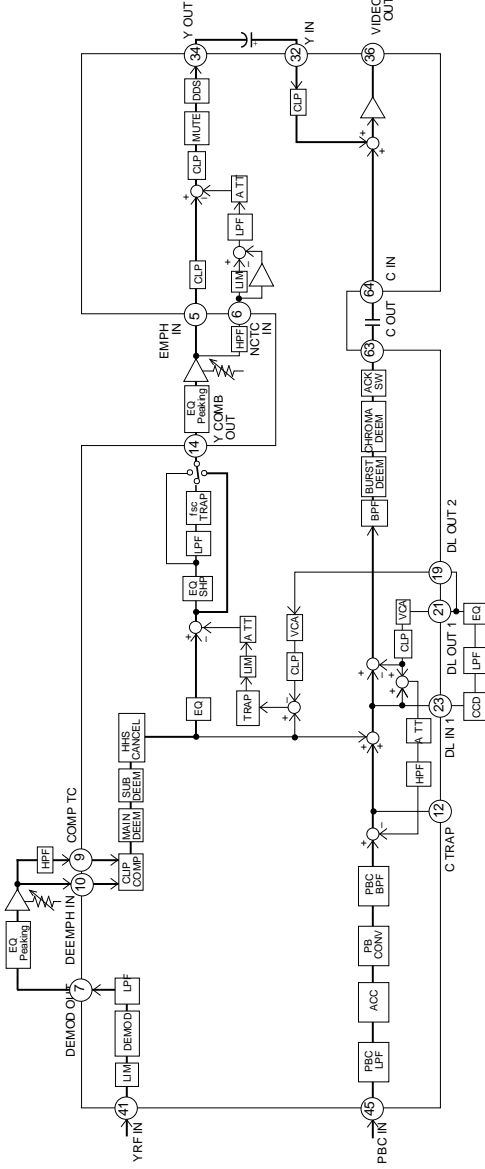

Pin No.	(41)	(7) (10)	(14) (5) (34) (32)	(45)	(12)	(63) (64)	(23) (21) (19) (36)
Signal waveform							
	0.2Vp-p	0.17Vp-p	0.5Vp-p	0.5Vp-p	0.3Vp-p	0.3Vp-p	0.5Vp-p 0.5Vp-p 2Vp-p

3. REC LEVEL adjustment

The video signal input to VIN1 (Pin 30) and VIN2 (Pin 28) is selected by mode INSEL, and when mode video AGC is High, the signal is passed through SYNC AGC and PEAK AGC and then is output from Y OUT (Pin 34). The output level can be adjusted by applying an external DC bias (1.3 to 2.6V [Vcc = 4.75V]) to RECL/JVD (Pin 31). In the case of white 100%, 500mVp-p input, the following are the standard characteristics.

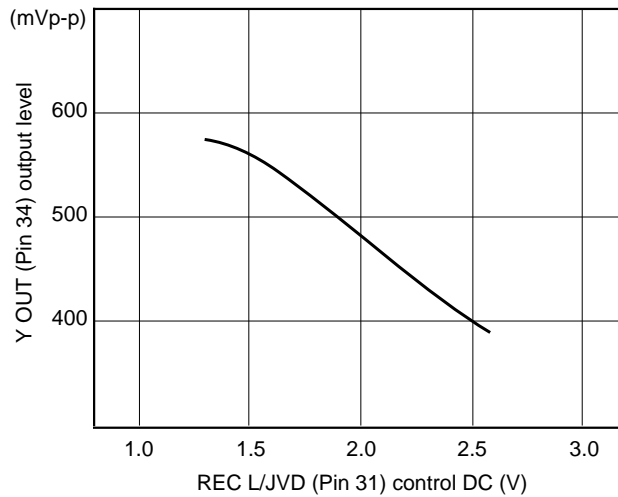

4. MASK DDS

DDS/MASK (Pin 26) is the VOW (character level) signal and the VOB (character background) and masking timing pulse input pin. The threshold value for source signal and VOB/masking is 1.1V, and the threshold value for VOB/masking and VOW is 2.0V (when Vcc = 4.75V). In addition, the VOW replacement signal level can be varied within the range of the DC level (2.3V to 3.0V) for this pin; those standard characteristics are shown below.

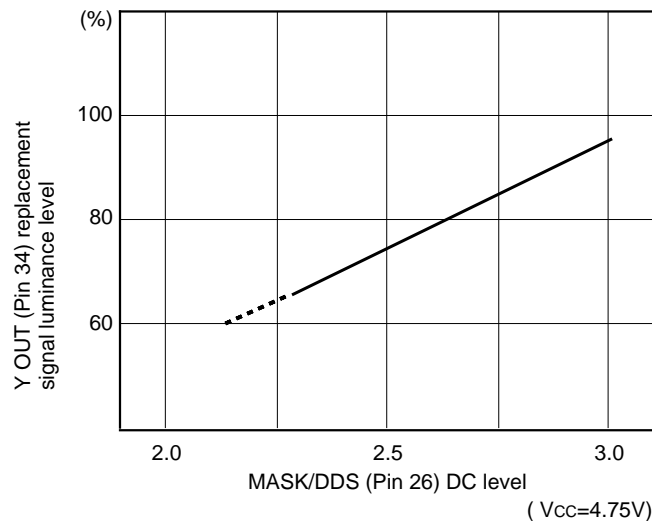

5. White/dark clipping adjustment

The white/dark clipping levels can be varied connectedly using the DC level of WDC (Pin 27). In addition, the dark clipping level is switched independently by DC1 and DC2 of the mode. The standard characteristics of Y pre-emphasis are shown below. (when white 100%, 500mVp-p input to Pin 5 EMPH IN)

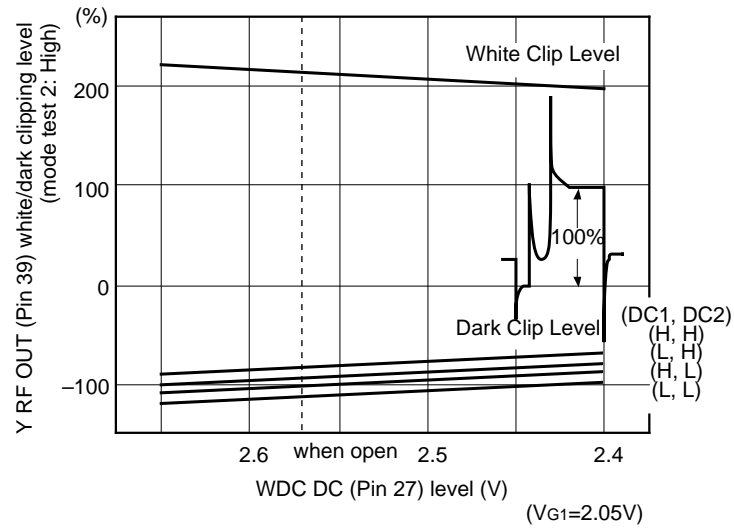

6. Carrier/deviation adjustment

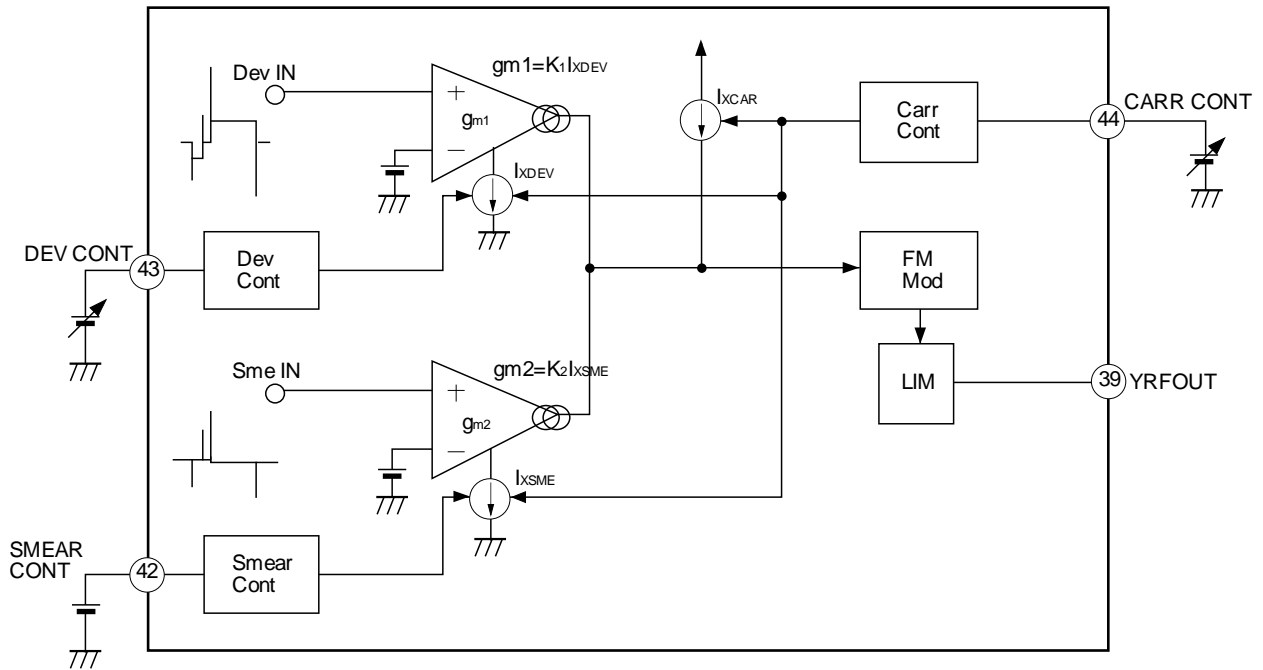

The Y FM modulation carrier frequency is adjusted by applying an external DC bias to CARR CONT (Pin 44). When carrier adjustment is performed,  $gm_1$  and  $gm_2$ , the deviation/smear gain, change in proportion to  $I_{XCAR}$  at the same time. This results in the FM modulator sensitivity being roughly adjusted for the Dev IN/Sme IN signal level. Fine adjustment of the deviation frequency is accomplished by the DC bias applied to DEV CONT (Pin 43).

6-1. Carrier frequency adjustment

The standard characteristics of carrier frequency for the CARR CONT (Pin 44) DC bias (1.8V to Vcc) when bias was applied to EMPH IN (Pin 5) with VG1 are shown below.

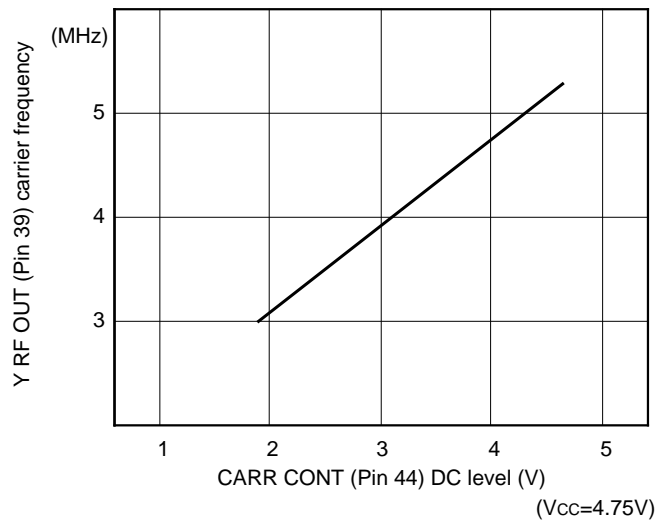

6-2. Deviation frequency adjustment

The standard characteristics of deviation frequency for the DEV CONT (Pin 43) DC bias (1.8V to Vcc) when bias was applied to EMPH IN (Pin 5) with VG1 + 0.5V after carrier frequency adjustment are shown below.

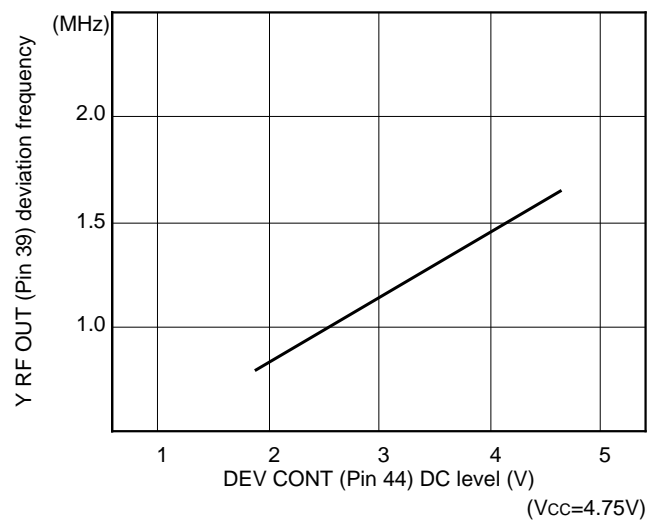

7. Chroma emphasis fo adjustment

The center frequency of the chroma emphasis characteristics is adjusted by the DC bias (1.8V to 3.8V [Vcc = 4.75V]) applied to CE CONT (Pin 1). The standard characteristics of center frequency for the CE CONT (Pin 1) DC level are shown below.

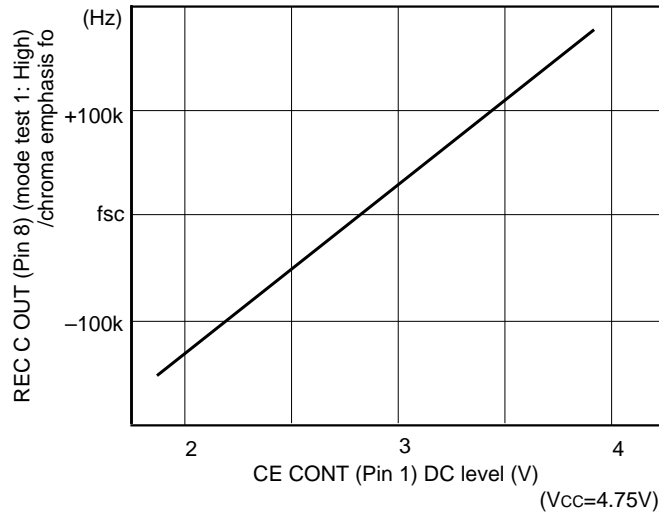

8. ACC/ACK standard characteristics

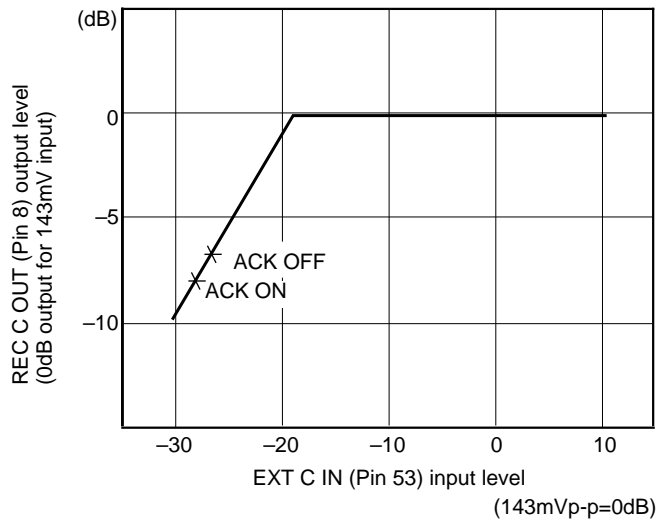

9. Y cross talk cancellation

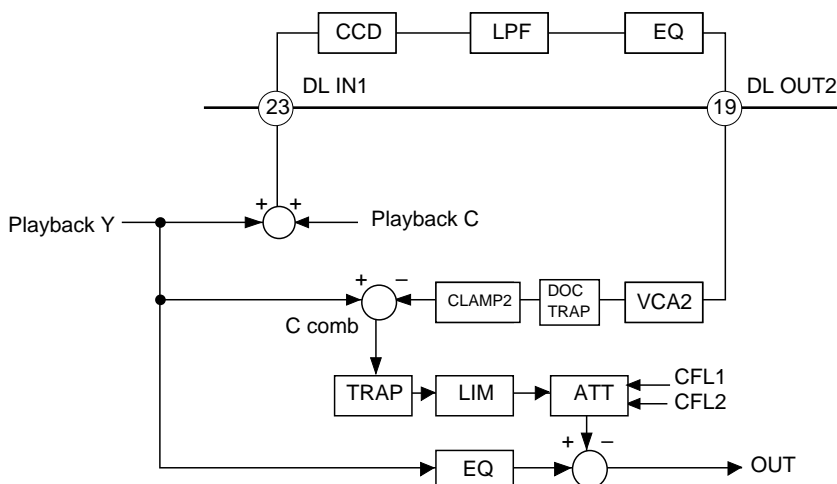

De-emphasized playback Y signal is input to the comb block. By passing the differential component of the  $nH$  signal and the  $(n+1)H$  signal through the limiter, the cross talk component, which is line noncorrelation, is extracted. Cross talk cancellation is accomplished by subtracting this cross talk component from the  $nH$  playback Y signal.

In addition, by switching mode CFL1 and CFL2, the comb depth characteristics of PB Y cross talk cancellation can be changed. The standard characteristics of comb depth for low frequency (approximately 1MHz) and insignificant input level (MAIN EMPH TC (Pin 3) 7.9mVp-p = -30dB) input are shown below.

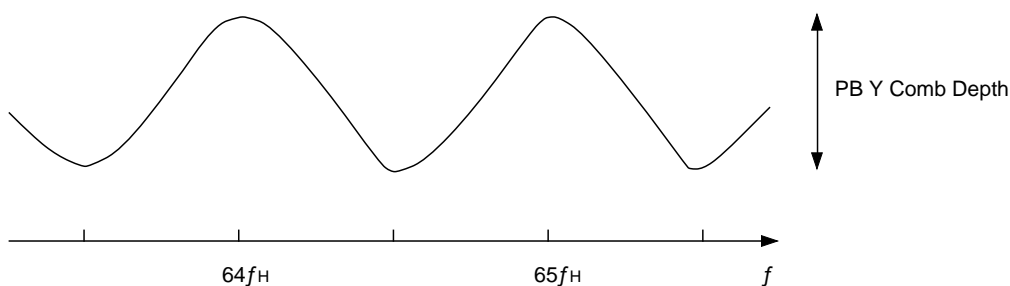

	CFL1	High	Low
CFL2	High	-10dB	-6dB
	Low	-1.5dB	0dB

10. PB C cross talk cancellation

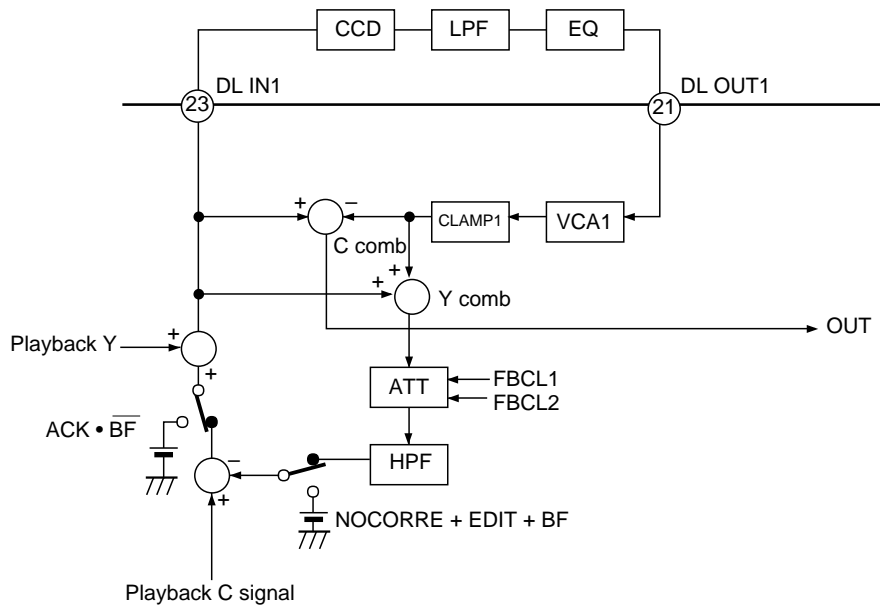

The playback C signal which passes through the BPF is input after frequency conversion. The feedback chroma comb filter is configured as shown above.

By switching mode FBCL1 and FBCL2, the feedback loop gain from the Y comb is changed as shown below.

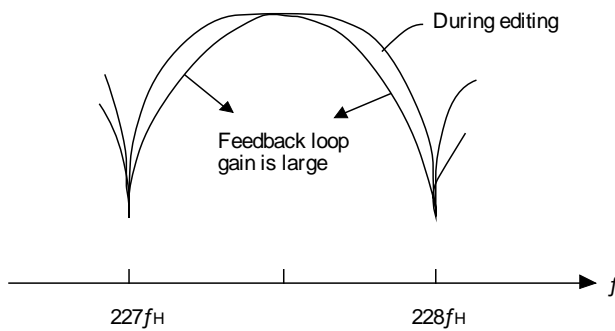

Feedback loop gain

FBCL1 \ FBCL2	High	Low
High	6.7dB	4.8dB
Low	1.9dB	0dB

When the feedback loop gain is increased the S/N ratio can be improved, but note that color smear in the vertical direction and transient response get worse.

11. PB Y noise cancellation

When an external HPF is configured as shown below, the standard characteristics of PB Y noise cancellation are as shown below, depending on the switching of input signal level, mode NCL1/2, external HPF and NCLP1/2.

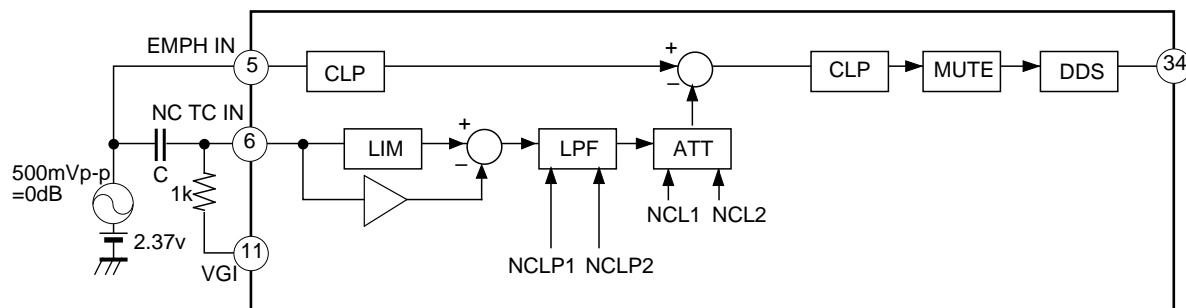

1) Changes in frequency characteristics due to the input level

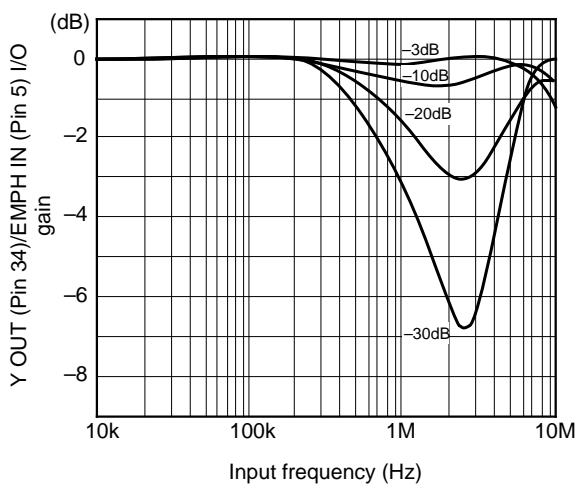

NCL 1, 2 = H, H  
 NCLP 1, 2 = H, H  
 External HPF (1kΩ/82pF)

2) Changes in frequency characteristics due to switching of mode NCL1/2

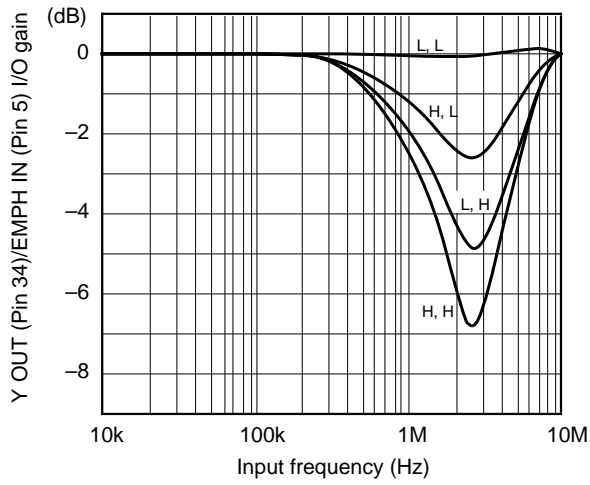

NCLP 1, 2 = H, H  
External HPF (1kΩ/82pF)

3) Changes in frequency characteristics due to switching of external HPF and mode NCLP1,2

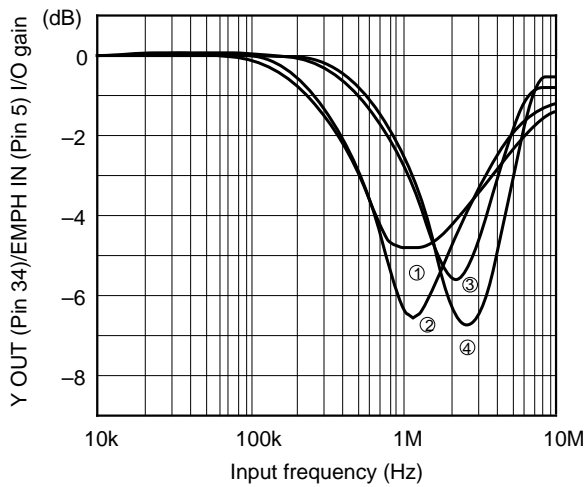

NCL 1, 2 = H, H

The following four conditions are compared:

	NCLP1	NCLP2	External HPF
①	L	L	1kΩ/220pF
②	H	L	1kΩ/220pF
③	L	H	1kΩ/82pF
④	H	H	1kΩ/82pF

## 12. BF OUT pulse

The timing for C SYNC (Pin 24) output pulse and BF VCO (Pin 62) output pulse changes in each mode as shown below. Note that the BPF delay time between C OUT (Pin 63) and C IN (Pin 64) during PAL playback is designed to be 200ns. In addition, the BF pulse width  $W_{dBF}$  is constant.

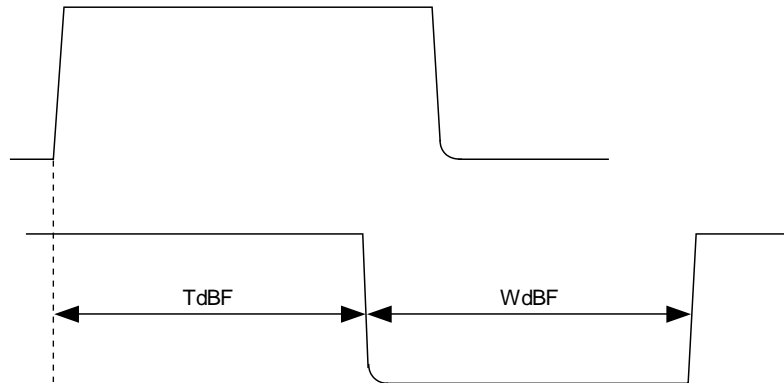

PB :  $T_{dBF} (PB)$   
NTSC • REC :  $T_{dBF} (PB) + 250nsec$   
PAL • REC :  $T_{dBF} (PB) + 390nsec$

**Adjustment Procedure (Refer to Application Circuit.)**

1. REC Y level adjustment  
Mode : REC, 29 video AGC = High  
Input signal : color bar 500mVp-p (Pin 30 V IN1)  
Adjustment method : When VIDEO OUT (Pin 36) is terminated with 75Ω, adjust RV105 (EE LEVEL) so that the output is 1Vp-p.
2. Y/C separation adjustment  
Mode: REC, 5 SHP THRU = High  
Input signal : color bar 500mVp-p (Pin 30 V IN1)  
Adjustment method : Adjust RV110 (YC.SEP) → RV103 (COMB.ADJ) → RV110 (YC.SEP) in turn so that the residual chroma component at Y COMB OUT (Pin 14) is minimum.
3. Emphasis input Y level adjustment  
Mode : REC  
Input signal : color bar 500mVp-p (Pin 30 V IN1)  
Adjustment method : Adjust RV112 (EMPH.Y.LEV) so that the Y signal level at EMPH IN (Pin 5) is 500mVp-p.
4. Y-FM carrier deviation adjustment  
Mode : REC, 22 E = Low (standard mode)  
Input signal : 100% white, 500mVp-p (Pin 30 V IN1)  
Adjustment method : While monitoring the Y RF OUT (Pin 39) signal with a spectrum analyzer, adjust RV108 (CARR) so that the H SYNC spectrum (carrier) is 4.2MHz in standard mode, and adjust RV107 (DEV) so that the 100% white Y level spectrum is 5.4MHz in standard mode.
5. Chroma emphasis fo adjustment  
Mode : REC, 2 TEST1 = high  
Input signal : color bar 500mVp-p (Pin 30V IN1)  
Adjustment method : Adjust RV102 (CEMPH) so that the level of the flat portion of the chroma signal after burst emphasis output to REC C OUT (Pin 8) is minimum.
6. PB Y level 1 adjustment  
Mode : PB  
Input signals : PB Y RF 200 =mVp-p (Pin 41 Y RF IN)  
Adjustment method : Adjust RV111 (PB.Y.LEV1) so that DL IN 1 (Pin 23) Y signal level is 500mVp-p.
7. PB Y level 2 adjustment  
Mode : PB  
Input signal : PB Y RF 200mVp-p (Pin 41 Y RF IN)  
Adjustment method : When VIDEO OUT (Pin 36) is terminated with 75Ω, adjust RV113 (PB.Y.LEV2) so that the output is 1Vp-p.

**Note on Operation**

- Connect NC (Pin 17) to GND directly.
- I REF (Pin 55) resistance 18k, determines the reference current. Employ a metallic film resistance and of allowable difference ±1%.

Application circuit (NTSC NORMAL)

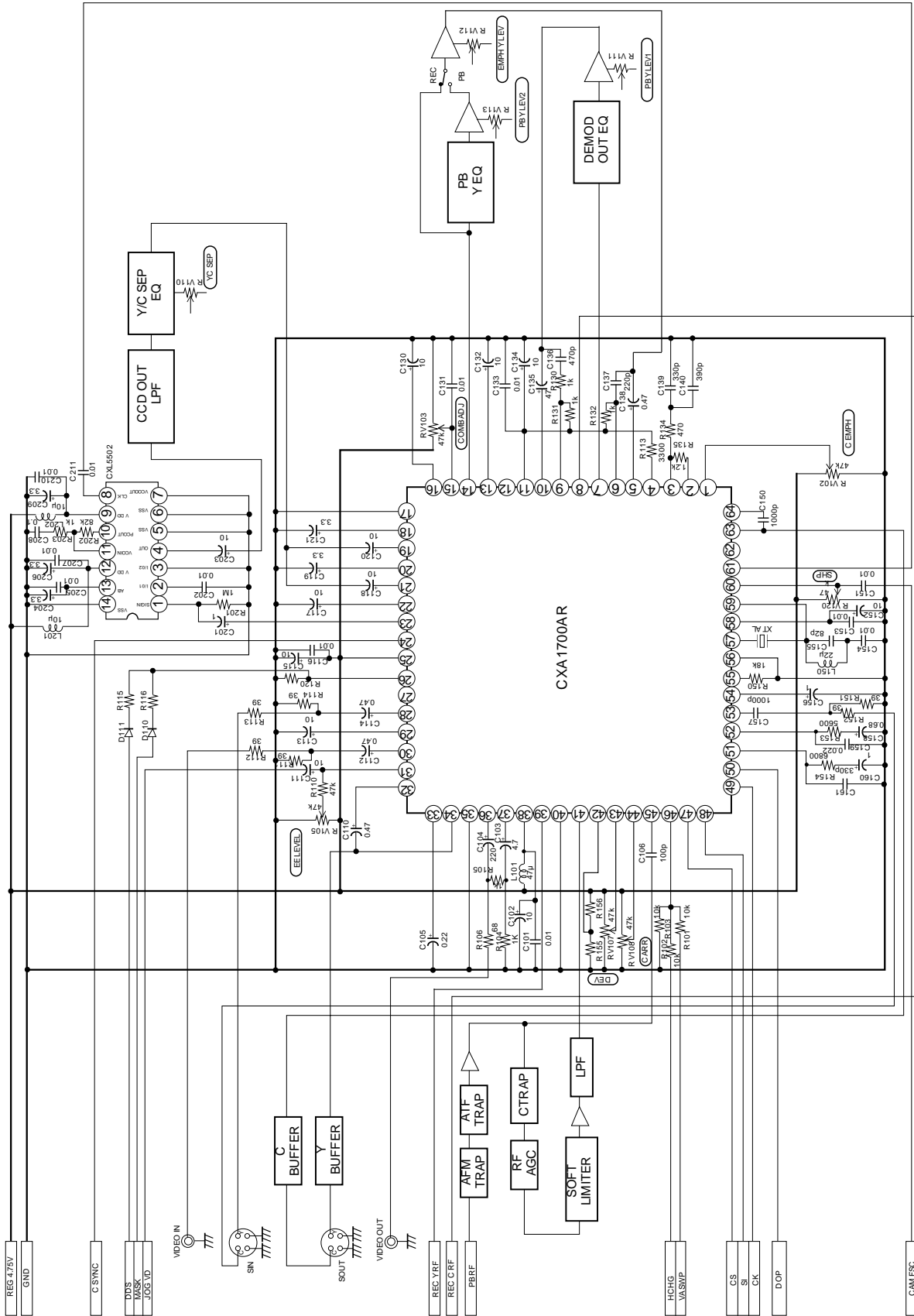

Application circuits shown are typical examples illustrating the operation of the devices. Sony cannot assume responsibility for any problems arising out of the use of these circuits or for any infringement of third party and other right due to same.



Package Outline Unit : mm

CXA1700AQ

64PIN QFP(PLASTIC)

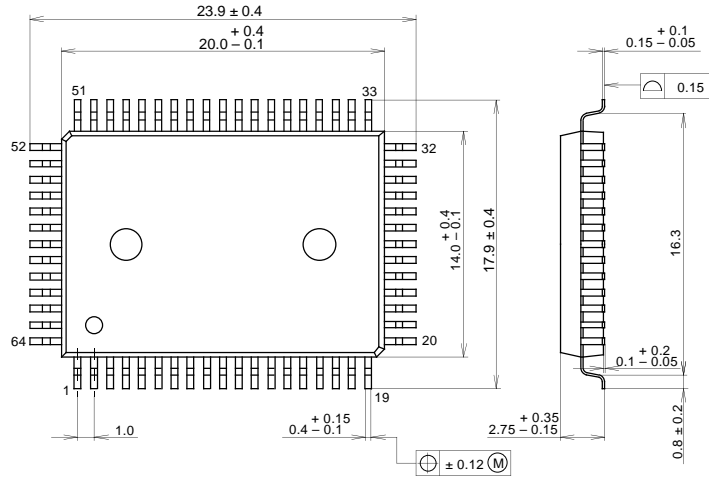

PACKAGE STRUCTURE

SONY CODE	QFP-64P-L01
EIAJ CODE	*QFP064-P-1420
JEDEC CODE	

PACKAGE MATERIAL	EPOXY RESIN
LEAD TREATMENT	SOLDER/PALLADIUM PLATING
LEAD MATERIAL	COPPER /42 ALLOY
PACKAGE WEIGHT	1.5g

CXA1700AR

64PIN LQFP (PLASTIC)

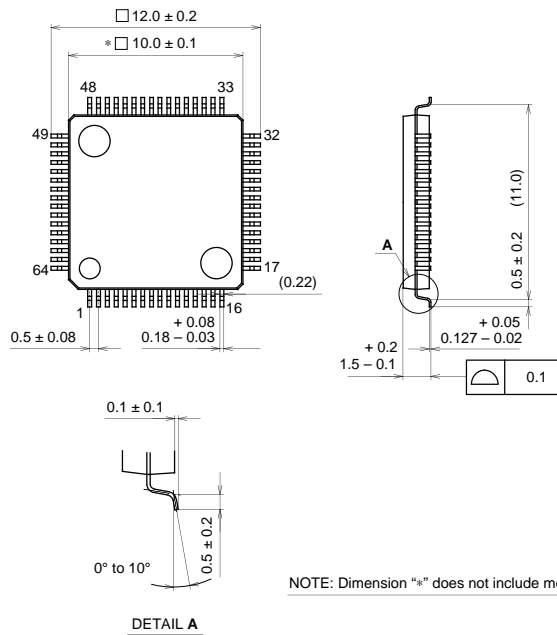

NOTE: Dimension "\*" does not include mold protrusion.

DETAIL A

PACKAGE STRUCTURE

SONY CODE	LQFP-64P-L01
EIAJ CODE	*QFP064-P-1010-A
JEDEC CODE	

PACKAGE MATERIAL	EPOXY / PHENOL RESIN
LEAD TREATMENT	SOLDER PLATING
LEAD MATERIAL	42 ALLOY
PACKAGE WEIGHT	0.3g

This datasheet has been downloaded from:

[www.DatasheetCatalog.com](http://www.DatasheetCatalog.com)

Datasheets for electronic components.



LittleDiode supplies new, hard to find or obsolete electronic components and semiconductors all over the world.

With over two million different components listed you are sure to find the part you need.

Feel free to visit us today at our online store:

[LittleDiode.com](http://LittleDiode.com)

Looking forward to providing you with the best possible service.