

Electronic Volume

Description

The CXA1746Q is a 2-channel electronic volume IC. A 34-bit serial data input controls the level and characteristics of the output signal. It may be used in car stereos and general audio systems.

Features

- Loudness
- Volume control
(from 0 dB to -87 dB, $-\infty$ dB: Fine (1 dB-step)
Coarse (8 dB-step))
- Balance
- Tone control
(3-band, 2 dB-step from -15 dB to +15 dB)
- Fader
(2 dB-step to -20 dB, -25 dB, -35 dB, -45 dB, -60 dB, $-\infty$ dB)
- Input and gain selector (4 channels)
- Serial data control (DATA, CLK, CE)
- Single 8 V power supply
- Zero-cross detection circuit
- Timer
- Power-off mute

Structure

Bipolar IC

48 pin QFP (Plastic)

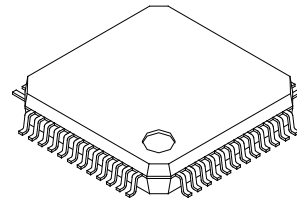

Absolute Maximum Ratings (Ta=25°C)

• Supply voltage	V _{CC}	13	V
• Operating temperature	T _{opr}	-40 to +85	°C
• Storage temperature	T _{stg}	-65 to +150	°C
• Allowable power dissipation	P _D	350	mW (T _a = 85 °C)

Recommended Operating Condition

• Supply voltage	V _{CC}	6 to 12	V
------------------	-----------------	---------	---

Block Diagram and Pin Configuration

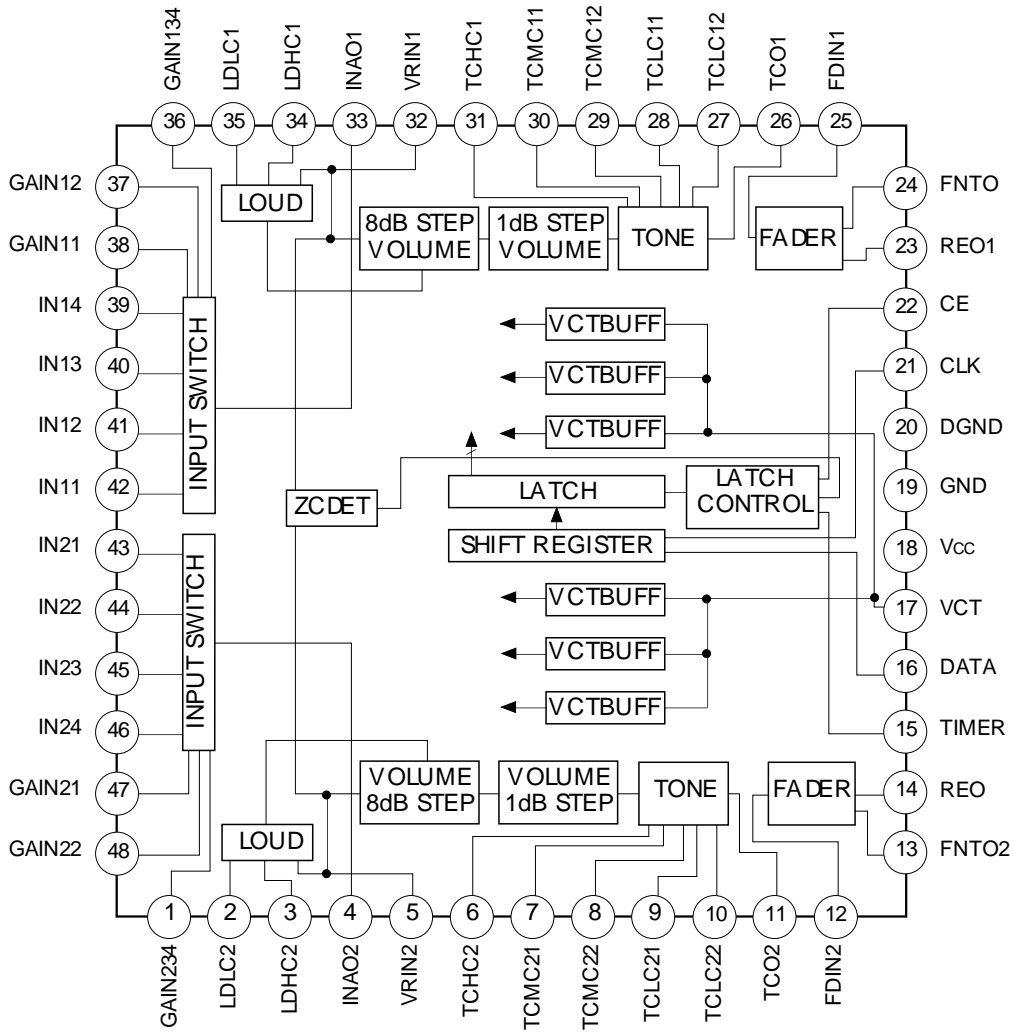

Pin Description and Equivalent Circuit

Pin No.	Pin Name	I/O Resistance Pin voltage	Equivalent Circuit	Description
2 35	LDLC2 LDLC1	6.18k VCT		Sets loudness low cut-off frequency.
3 34	LDHC2 LDHC1	8.92k VCT		Set loudness high cut-off frequency
4 33	INAO2 INAO1	— VCT		Input selector output
5 32	VRIN2 VRIN1	10k VCT		Volume input
6 31	TCHC2 TCHC1	5k VCT		Set tone Treble frequency

Pin No.	Pin Name	I/O Resistance Pin voltage	Equivalent Circuit	Description
7 30	TCMC21 TCMC11	4k VCT		Sets tone Mid frequency
8 29	TCMC22 TCMC12	4k VCT		Sets tone Mid frequency
9 28	TCLC21 TCLC11	8k VCT		Sets tone Bass frequency
10 27	TCLC22 TCLC12	8k VCT		Sets tone Bass frequency
11 26	TCO2 TCO1	— VCT		Tone control output

Pin No.	Pin Name	I/O Resistance Pin voltage	Equivalent Circuit	Description
12 25	FDIN2 FDIN1	24k VCT		Fader input
13 24	REO2 REO1	— VCT		Rear output
14 23	FNT02 FNT01	— VCT		Front output
15	TIMER	$\approx \infty$ —		Sets timer constant
16	DATA	$\approx \infty$ —		Serial data input

Pin No.	Pin Name	I/O Resistance Pin voltage	Equivalent Circuit	Description
17	VCT	— VCT		1/2 Vcc
18	Vcc	— Vcc		Power supply input
19	GND	— Gnd		Ground
20	DGND	— —		Digital ground
21	CLK	$\approx \infty$ —		Serial clock input
22	CE	$\approx \infty$ —		Latch enable input
1 36 37 38 47 49	GAIN234 GAIN134 GAIN12 GAIN11 GAIN21 GAIN22	$\approx \infty$ VCT		External gain setting for input amplifier
39 40 41 42 43 44 45 46	IN14 IN13 IN12 IN11 IN21 IN22 IN23 IN24	50k VCT		Signal input

Data Format

First Bit	D1	NOP	
	D2	NOP	
	D3 D4	ISW	
	D5	LOUD	
	D6 D7 D8 D9	VRC1	
	D10 D11 D12	VRF1	
	D13 D14 D15 D16	VRC2	
	D17 D18 D19	VRF2	
	D20 D21 D22 D23	TONE BASS	
	D24 D25 D26 D27	TONE MID	
	D28 D29 D30 D31	TONE TREBLE	
	D32 D33 D34 D35	FADER	
	Last Bit	D36	FADER SELECT

ISW

MODE	D3	D4
IN14/IN24, GAIN134/GAIN234	1	1
IN13/IN23, GAIN134/GAIN234	1	0
IN12/IN22, GAIN12/GAIN22	0	1
IN11/IN21, GAIN11/GAIN21	0	0

LOUD

MODE	D5
ON	1
OFF	0

VRC1/VRC2

OUTPUT (dB)	D6/D13	D7/D14	D8/D15	D9/D16
0	1	1	1	1
-8	1	1	1	0
-16	1	1	0	1
-24	1	1	0	0
-32	1	0	1	1
-40	1	0	1	0
-48	1	0	0	1
-56	1	0	0	0
-64	0	1	1	1
-72	0	1	1	0
-80	0	1	0	1
-∞	0	1	0	0
-∞	0	0	0	0

VRF1/VRF2

OUTPUT (dB)	D10/D17	D11/D18	D12/D19
0	1	1	1
-1	1	1	0
-2	1	0	1
-3	1	0	0
-4	0	1	1
-5	0	1	0
-6	0	0	1
-7	0	0	0

BASS/MID/TREBLE

OUTPUT (dB)	D20/D24/D28	D21/D25/D29	D22/D26/D30
15	1	1	1
12	1	1	0
10	1	0	1
8	1	0	0
6	0	1	1
4	0	1	0
2	0	0	1
0	0	0	0

BOOST/CUT

MODE	D23/D27/D31
BOOST	1
CUT	0

FADER

OUTPUT (dB)	D32	D33	D34	D35
-∞	1	1	1	1
-60	1	1	1	0
-45	1	1	0	1
-35	1	1	0	0
-25	1	0	1	1
-20	1	0	1	0
-18	1	0	0	1
-16	1	0	0	0
-14	0	1	1	1
-12	0	1	1	0
-10	0	1	0	1
-8	0	1	0	0
-6	0	0	1	1
-4	0	0	1	0
-2	0	0	0	1
0	0	0	0	0

FADER SELECT

MODE	D36
FRONT	1
REAR	0

RESET

Reset is performed automatically when power is first supplied to the IC; there is no reset pin.

The following table shows the respective statuses of various settings after a reset has been performed.

However, from the time when power is first supplied until the first data transfer, keep CE high by pulling it up to Vcc, etc.

MODE	SET VALUE
INPUT	1
VRC1	-∞dB
VRF1	-7 dB
VRC2	-∞dB
VRF2	-7 dB
LOUD	OFF
TONE BASS	0 dB
TONE MID	0 dB
TONE TREBLE	0 dB
FADER	0 dB, REAR

Timing Chart

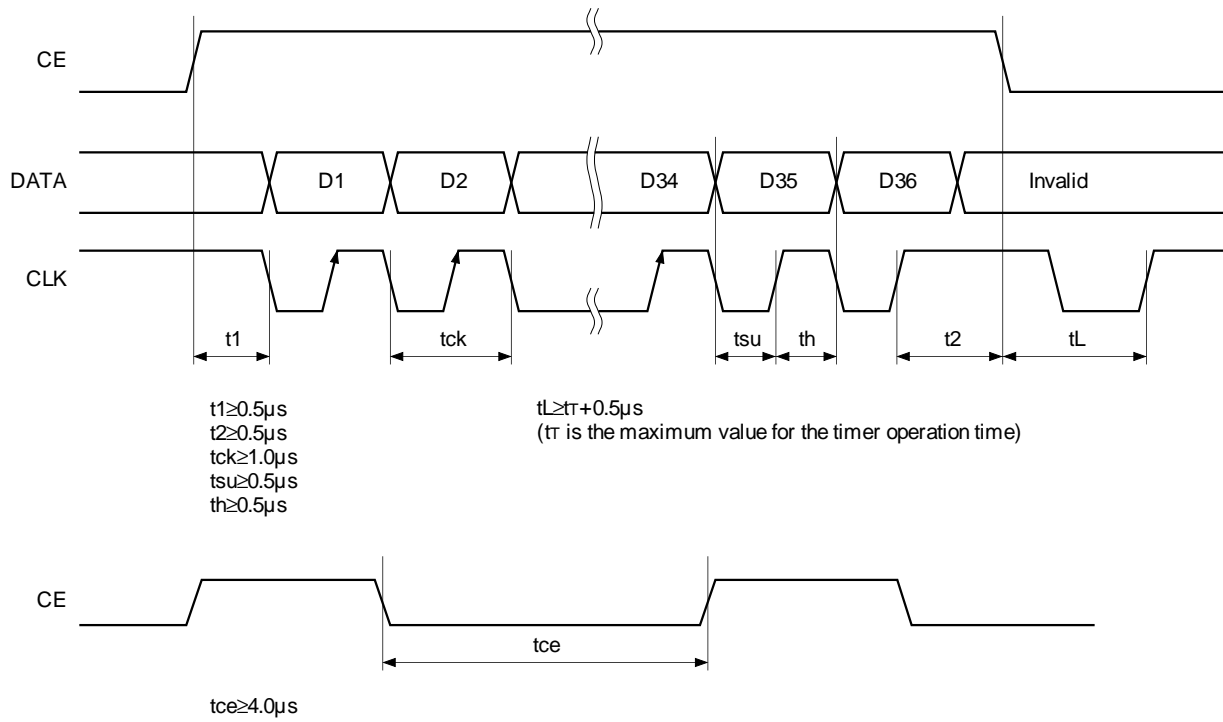

Timer Waiting Period Setting Chart ($V_{CC} = 6$ to $12V$, operating temperature = $-40^\circ C$ to $85^\circ C$)

TIMER pin capacitance C	Waiting period		
	Min.	Typ.	Max.
C = 100pF	3 μs	5 μs	9 μs
C = 0.001 μF	30 μs	50 μs	90 μs
C = 0.01 μF	300 μs	500 μs	900 μs
C = 0.1 μF	3ms	5ms	9ms
C = 1 μF	30ms	50ms	90ms
C = 10 μF	300ms	500ms	900ms

Electrical Characteristics

V_{cc}=8 V, T_a=25°C, Input=0 dB unless otherwise specified

Item	Symbol	Conditions	Min.	Typ.	Max.	Unit	
Current consumption	I _{cc}	No signal	—	21	23	mV	
Total Harmonic distortion	THD	1 kHz, 5 dBm output	—	0.003	0.01	%	
Output noise voltage	V _n	Short-circuit at input, A weight	—	8	10	μV _{rms}	
Max output voltage	V _{om}	1 kHz	8	—	—	dBm	
Separation	CS	1 kHz	72	90	—	dB	
Max. attenuation factor	ATT _m		85	90	—		
Loudness LOW	G _{lb}	100 Hz, VRC=−16 dB	7	8	9		
Loudness HIGH	G _{lh}	10 kHz, VRC=−16dB	7	8	9		
Bass max. boost gain	G _{bb}		13	15	17		
Bass max. cut gain	G _{bc}		13	15	17		
Mid max. boost gain	G _{mb}		13	15	17		
Mid max. cut gain	G _{mc}		13	15	17		
Treble max. boost gain	G _{tb}		13	15	17		
Treble max. cut gain	G _{tc}		13	15	17		
Input voltage HIGH	V _{sh}	DATA, CLK, CE	3	—	6		V
Input voltage LOW	V _{sl}	DATA, CLK, CE	0	—	1.5		
Input voltage range	V _{in}	IN11 to 14 IN21 to 24 VRIN1, 2 FDIN1, 2	1	—	V _{cc} -1		

Electrical Characteristic Test Circuit

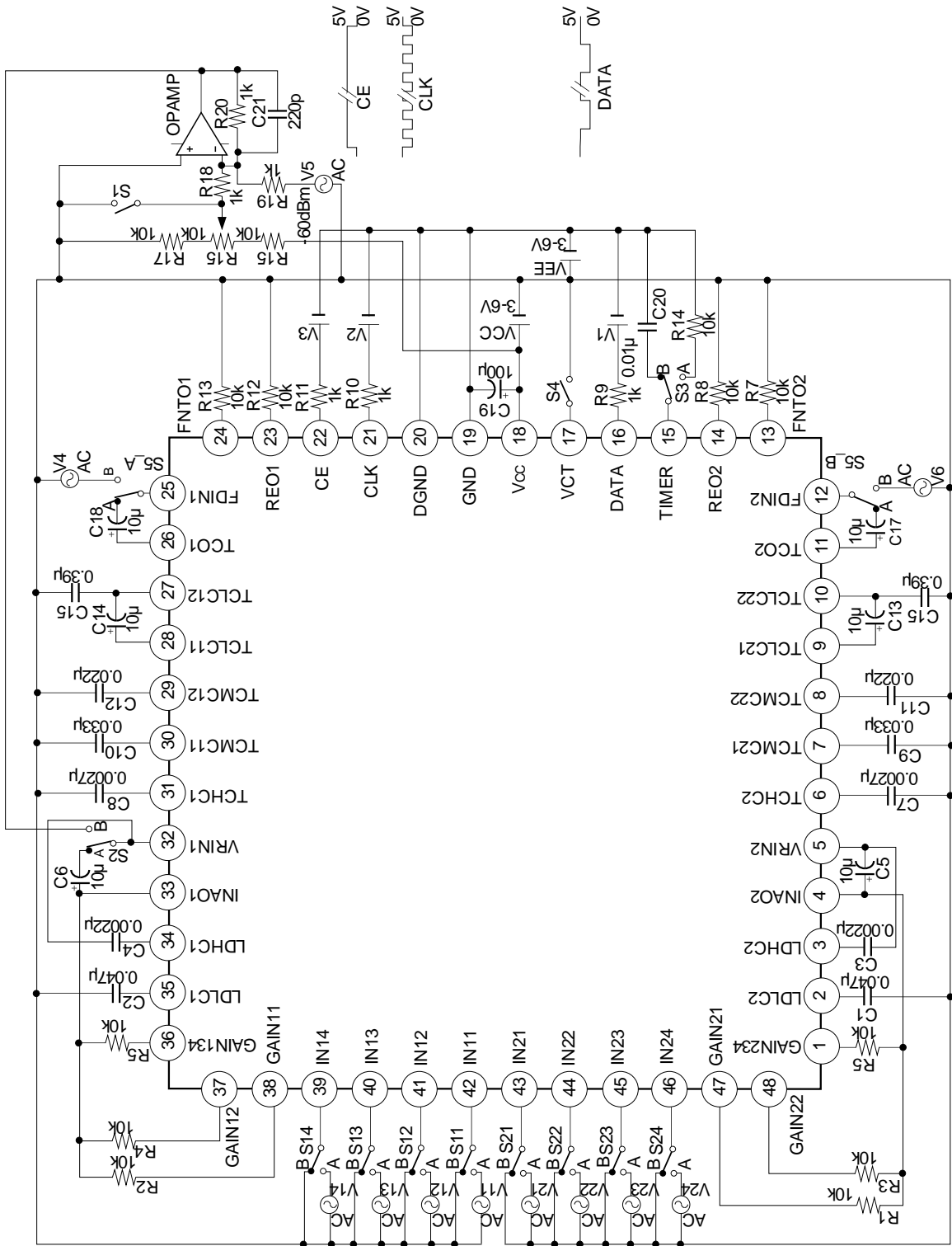

Application Circuit

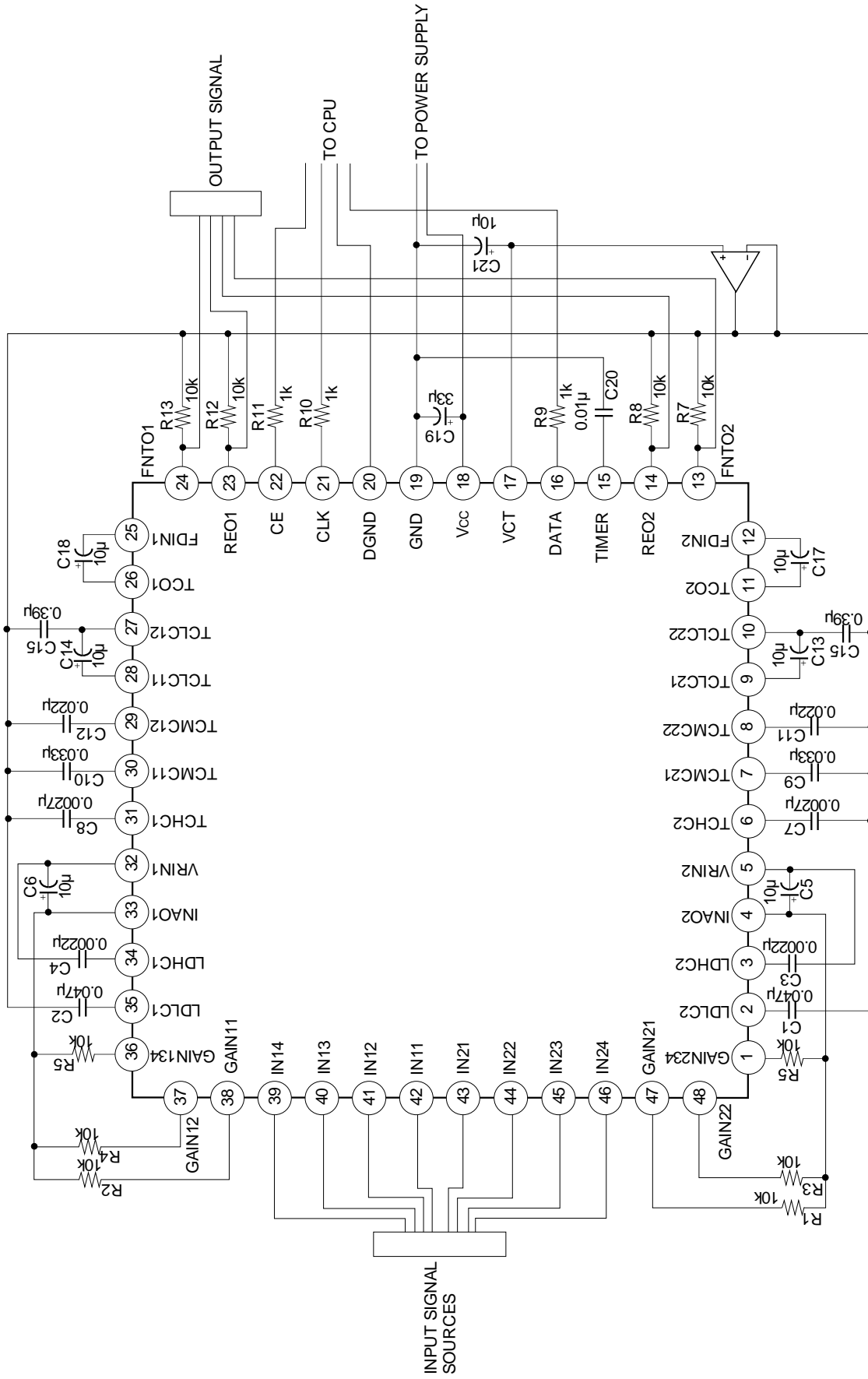

Application circuits shown are typical examples illustrating the operation of the devices. Sony cannot assume responsibility for any problems arising out of the use of these circuits or for any infringement of third party patent and other right due to same.

Description of Operation

(1) Gain of input amplifier

The input selector stage may be configured as a buffer or a non-inverting amplifier.

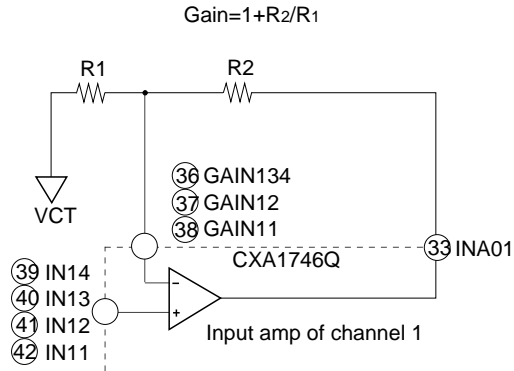

(2) Loud

The loudness function achieves the necessary frequency characteristics by using a filter as shown below. The resistors are built in so that f_L and f_H can be set by selecting C_1 and C_2 .

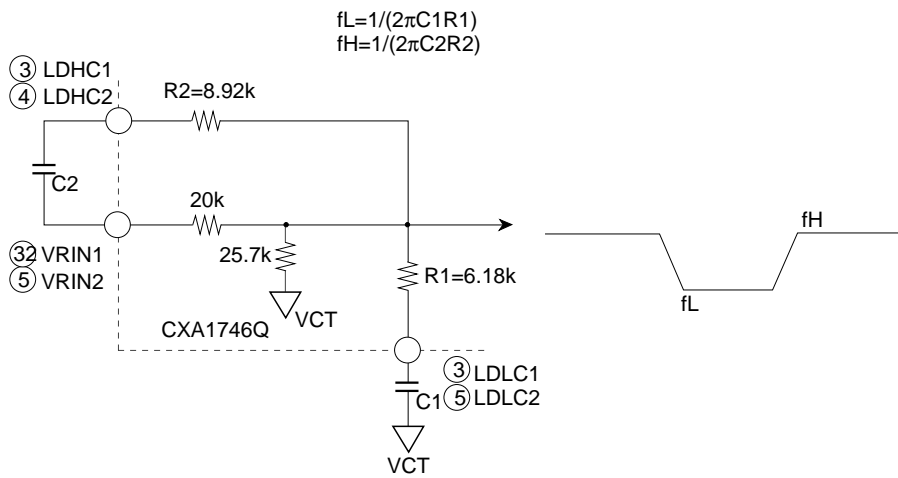

(3) Tone control
BASS: LPF

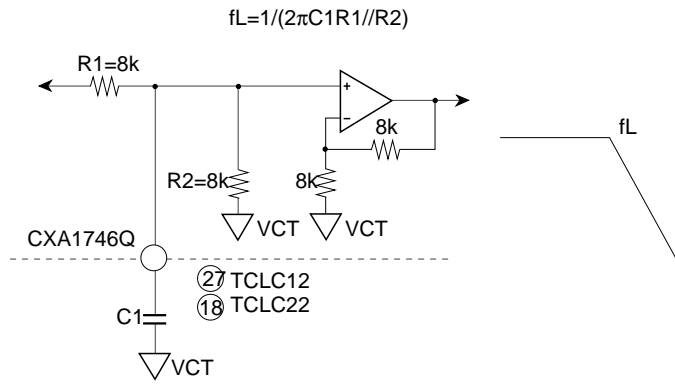

MID: BPF

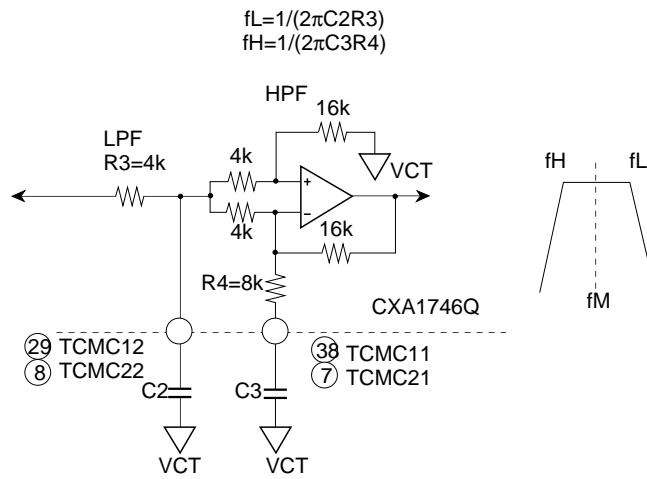

TREBLE: HPF

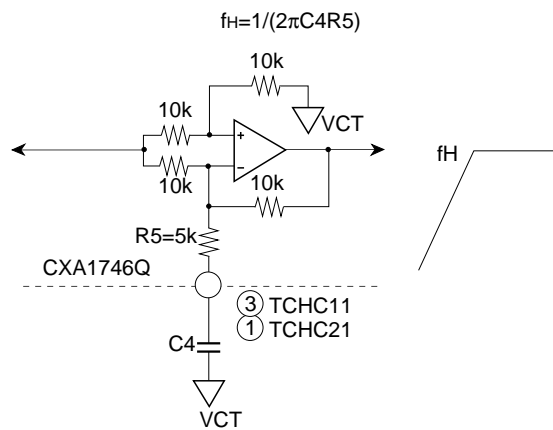

(4) Zero-cross detector and Timer

A built-in zero-cross detection circuit is used to detect the zero-cross points of the input signal. When data arrived at the IC, they are executed at the next zero-cross point or when there is no input signal. This is to minimize 'click' noise during the transition of levels.

The timer circuit is added to ensure that the data is executed even when a zero-cross point is not detected after a pre-determined period of time from the falling edge of the CE pulse.

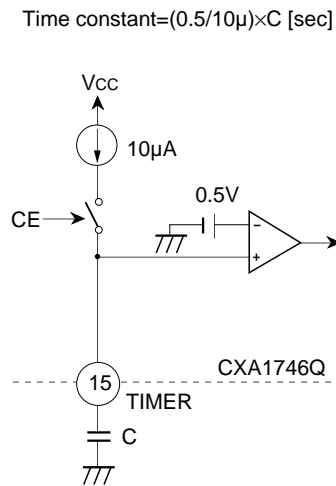

(5) VCT pin

The internal circuit of VCT pin has the following structure.

Insert a buffer when using it as a reference voltage for an external circuit.

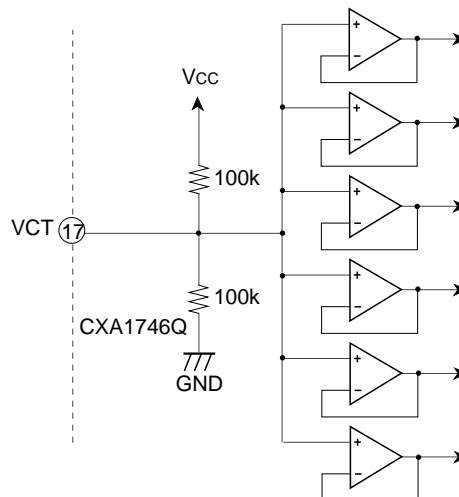

(6) Power-off Mute

This function mutes the output pins FNT01, FNT02, REO1 and REO2, when the Vcc goes below 5V, by turning off the bias of the output stage of the fader circuit. By so doing, the 'pop' noise caused by the drop in these pins potential from $V_{CC}/2$ during power-off can be avoided.

Example of Representative Characteristics

Tone Control Frequency Characteristics

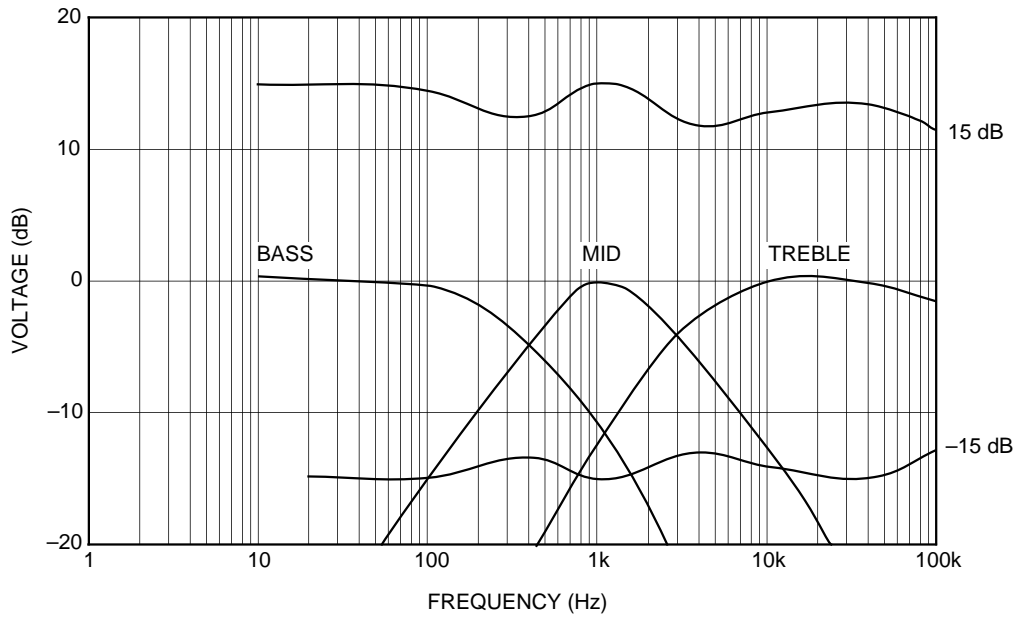

Loudness Frequency Characteristics

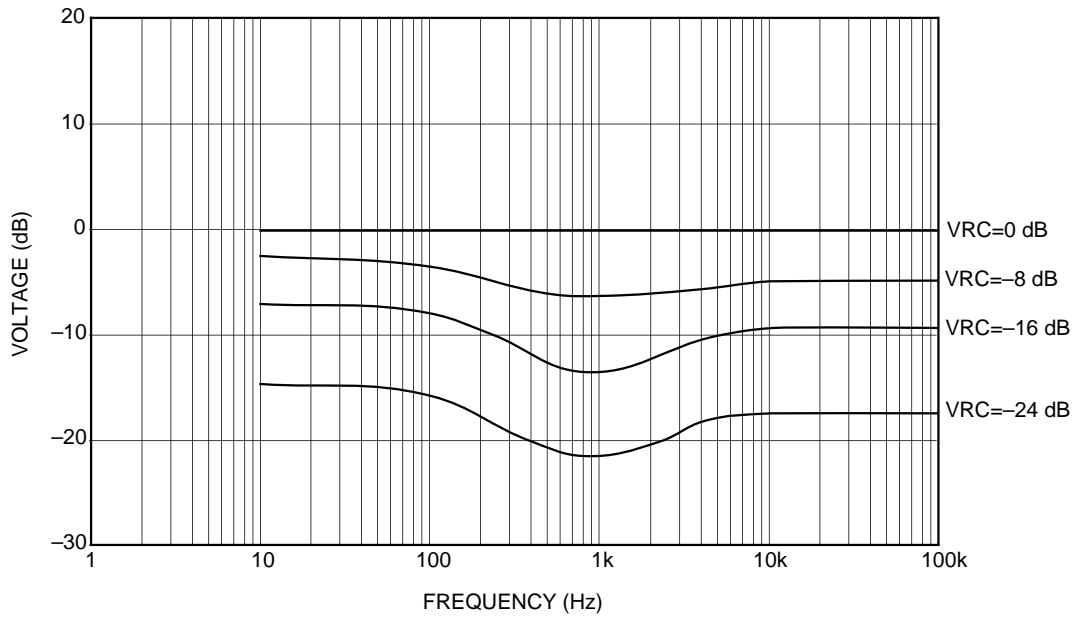

Package Outline Unit : mm

48PIN QFP (PLASTIC)

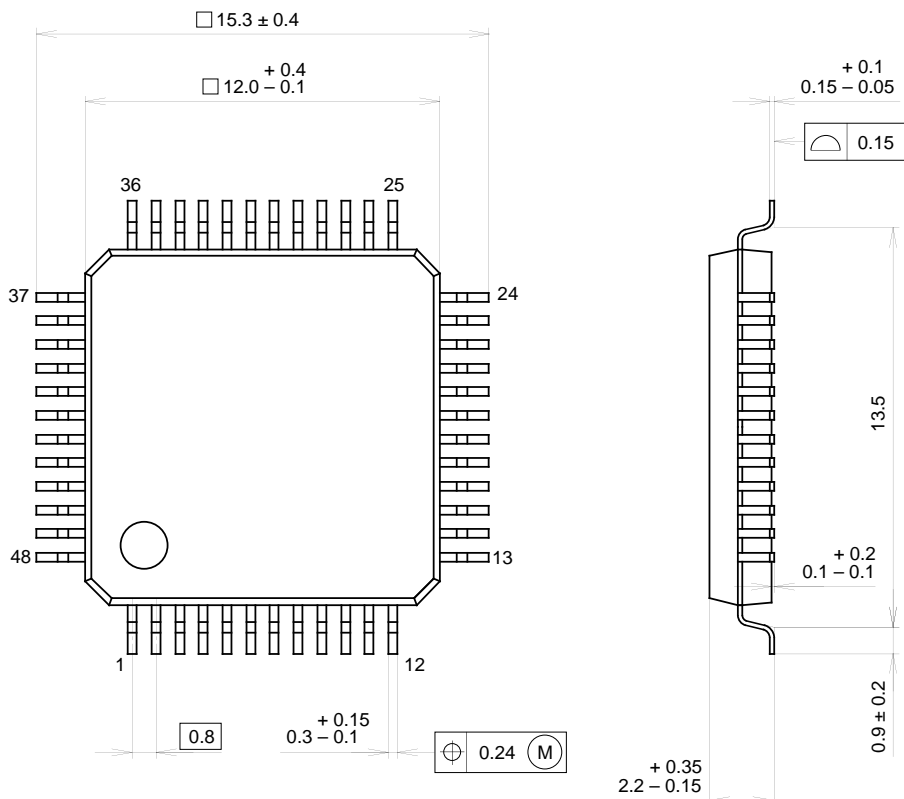

PACKAGE STRUCTURE

SONY CODE	QFP-48P-L04
EIAJ CODE	QFP048-P-1212
JEDEC CODE	_____

PACKAGE MATERIAL	EPOXY RESIN
LEAD TREATMENT	SOLDER / PALLADIUM PLATING
LEAD MATERIAL	42/COPPER ALLOY
PACKAGE MASS	0.7g



LittleDiode supplies new, hard to find or obsolete electronic components and semiconductors all over the world.

With over two million different components listed you are sure to find the part you need.

Feel free to visit us today at our online store:

LittleDiode.com

Looking forward to providing you with the best possible service.