

Headphone Stereos

Description

This is a bipolar IC designed for headphone stereos. It provides functions such as automatic volume limiter control, bass boost, standby, headphone driver and others.

Features

- Low quiescent current (3.2mA at 2.4V Vcc)
- Thermal shutdown circuitry at 120°C
- Headphone driver (30mW at 2.4V Vcc for 16Ω load)
- Bass boost function (9dB)
- Standby function
- Wide operating voltage (1.8 to 5V)
- Automatic volume limiter control (100mVrms)
- Uses SOP 16 pin package

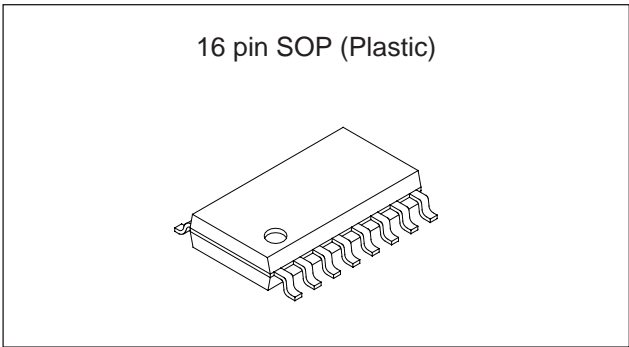

Application

Headphone Stereos

Structure

Bipolar silicon monolithic IC

Absolute Maximum Ratings (Ta = 25°C)

• Supply voltage	Vcc	7	V
• Operating temperature	Topr	-20 to +75	°C
• Storage temperature	Tstg	-65 to +150	°C
• Allowable power dissipation	P _D	500	mW

Operating Conditions

Supply voltage	Vcc	1.8 to 5	V
----------------	-----	----------	---

Sony reserves the right to change products and specifications without prior notice. This information does not convey any license by any implication or otherwise under any patents or other right. Application circuits shown, if any, are typical examples illustrating the operation of the devices. Sony cannot assume responsibility for any problems arising out of the use of these circuits.

Block Diagram and Pin Configuration

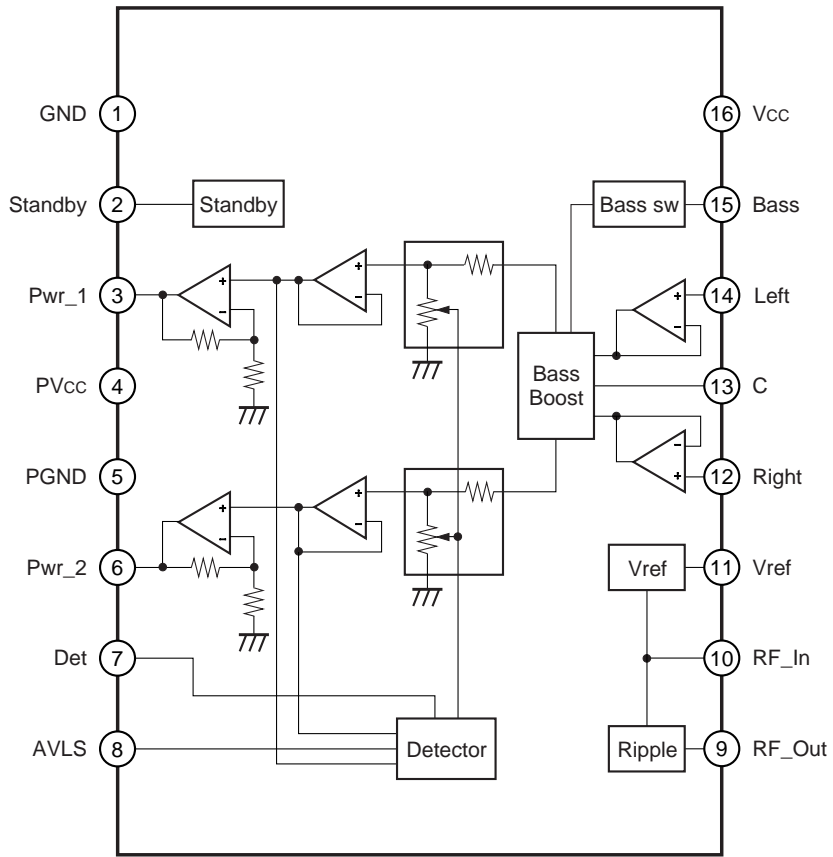

Pin Description

Pin No.	Symbol	Pin Voltage	Equivalent circuit	Description
1 5	GND PGND	0 0		Pre-amp ground Power amp ground
2	Standby	1		Standby switch H: Operate L: Standby
3 6	Pwr_1 Pwr_2	1.2 1.2		Left channel output Right channel output
4 16	PVcc Vcc	0 0		Power amp supply Pre-amp supply
7	Det	< 1		Detector output
8	AVLS	0		AVLS switch H: AVLS on L: AVLS off

Pin No.	Symbol	Pin Voltage	Equivalent circuit	Description
9 10	RF_Out RF_In	2.2 2.2		Ripple filter output
11	Vref	1.2		Voltage reference output
12 14	Right Left	1.2		Right channel input Left channel input
13	C	1.2		Low pass filter output

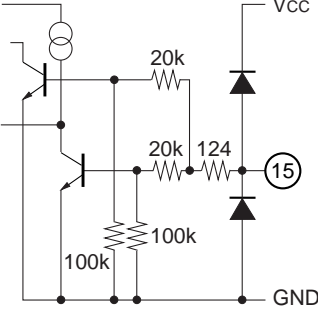
Pin No.	Symbol	Pin Voltage	Equivalent circuit	Description
15	Bass	1		<p>Bass switch H: Bass on L: Bass off</p>

Electrical Characteristics

Items	Symbols	Sw Condition					Vin	Vrr	Measurement conditions
		Sw1	Sw2	Sw3	Sw4	Sw5			
Current consumption 1	I _{CC1}	Off	On	Off	Off	Off			
Current consumption 2	I _{CC2}	Off	Off	Off	Off	Off			
Voltage gain 1	A _{V1}	Off	Off	Off	On	On	-20dBm		
Voltage gain 2	A _{V2}	Off	Off	On	On	On			BB on, ΔAv at 100Hz and 1kHz
AVLS output 1	V _{AVLS1}	On	Off	Off	On	On	50mVp-p		
AVLS output 2	V _{AVLS2}	On	Off	Off	On	On	250mVp-p		
Maximum Power	P _{O1}	Off	Off	Off	On	On			THD = 10%
Distortion factor	THD	Off	Off	Off	On	On			V _O = 0.3V _{rms}
Noise output	V _{no}	Off	Off	Off	Off	Off			R _g = 0, A-weight
Ripple Rejection	RR	Off	Off	Off	Off	Off		-20dBm	
Channel Separation	CS	Off	Off	Off	On/ off	Off/ on			V _O = -10dBv
Standby off	V _{standby}	Off	Off	Off	Off	Off			
Standby switch	I _{standby}	Off	Off	Off	Off	Off			V _{standby} = 1V
Bass on	V _{Bass}	Off	Off	On	Off	Off			
Bass switch	I _{Bass}	Off	Off	On	Off	Off			V _{Bass} = 1V
AVLS on	V _{avls}	On	Off	Off	Off	Off			
AVLS switch	I _{avls}	On	Off	Off	Off	Off			V _{avls} = 1V

(Unless otherwise specified. $T_a = 25^\circ\text{C}$, $V_c = 2.4\text{V}$, $R_L = 16\Omega$, $f = 1\text{kHz}$, standby off, AVLS off, BB off)

No.	Items	Symbols	Measurement conditions	Min.	Typ.	Max.	Units
1	Current consumption 1	I_{CC1}	Standby on	—	18	23	μA
2	Current consumption 2	I_{CC2}		—	3.2	5	mA
3	Voltage gain 1	A_{V1}	$V_{in} = -20\text{dBm}$	11	11.78	12	dB
4	Voltage gain 2	A_{V2}	BB on, ΔA_v at 100Hz and 1kHz	8	9.22	10	dB
5	AVLS output 1	V_{AVLS1}	AVLS on, $V_{in} = 50\text{mVp-p}$	86	103	116	mVrms
6	AVLS output 2	V_{AVLS2}	AVLS on, $V_{in} = 250\text{mVp-p}$	86	104	116	mVrms
7	Maximum Power	P_{O1}	$V_{CC} = 2.4\text{V}$, THD = 10%	15	30	—	mW
8	Distortion factor	THD	$V_O = 0.3\text{Vrms}$	—	0.13	0.3	%
9	Noise output	V_{no}	$R_g = 0$	—	-84	-80	dBm
10	Ripple Rejection	RR^{*1}	$f_R = 1\text{kHz}$, $V_{RR} = -20\text{dBm}$	36	61	—	dB
11	Channel Separation	CS^{*1}	$V_O = -10\text{dBv}$	-46	-50	—	dB
12	Standby off	$V_{standby}$			1		V
13	Standby switch	$I_{standby}$	$V_{standby} = 1\text{V}$		15		μA
14	Bass on	V_{Bass}			1		V
15	Bass switch	I_{Bass}	$V_{Bass} = 1\text{V}$		30		μA
16	AVLS on	V_{avls}			1		V
17	AVLS switch	I_{avls}	$V_{avls} = 1\text{V}$		15		μA

*1 Values are measured with respect to input source.

Electrical Characteristics Measurement Circuit

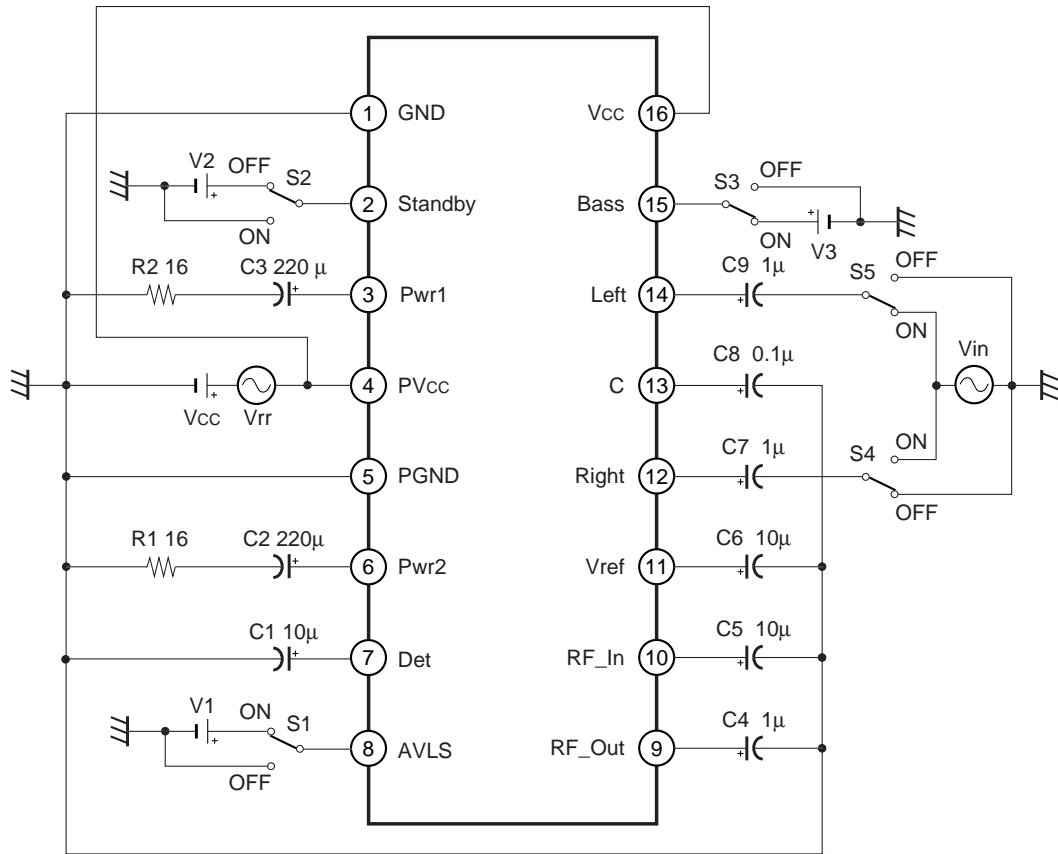

Description of Operation

1) Det Pin (Pin 7)

This is the external pin for the detector during AVLS mode. The attack time is determined by the internal charging buffer and the external capacitor. The recovery time is determined by both the 80k impedance inside the IC and the external capacitor.

2) RF_Out (Pin 9) / RF_In (Pin 10)

These are the two external pin for the power supply's ripple filter. It provides a regulated $0.92 \times V_{cc}$ to the internal circuits. The rejection ratio is determined by the resistors inside the IC and the two external capacitors.

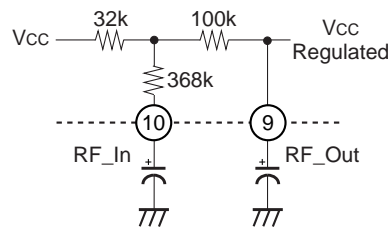

3) C Pin (Pin 13)

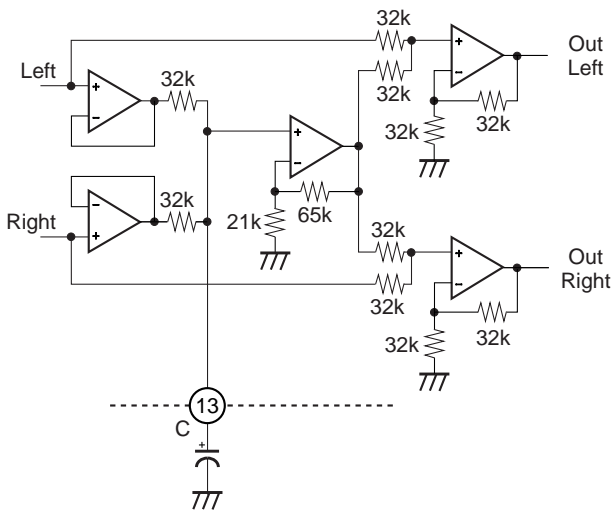

The bass boost circuitry is designed to provide a 9dB gain at 100Hz for $C = 0.1\mu\text{F}$.

The cut off frequency is determined by:

$$f_{\text{cutoff}} = \frac{1}{2\pi \times 16\text{k} \times C}$$

Application Circuit

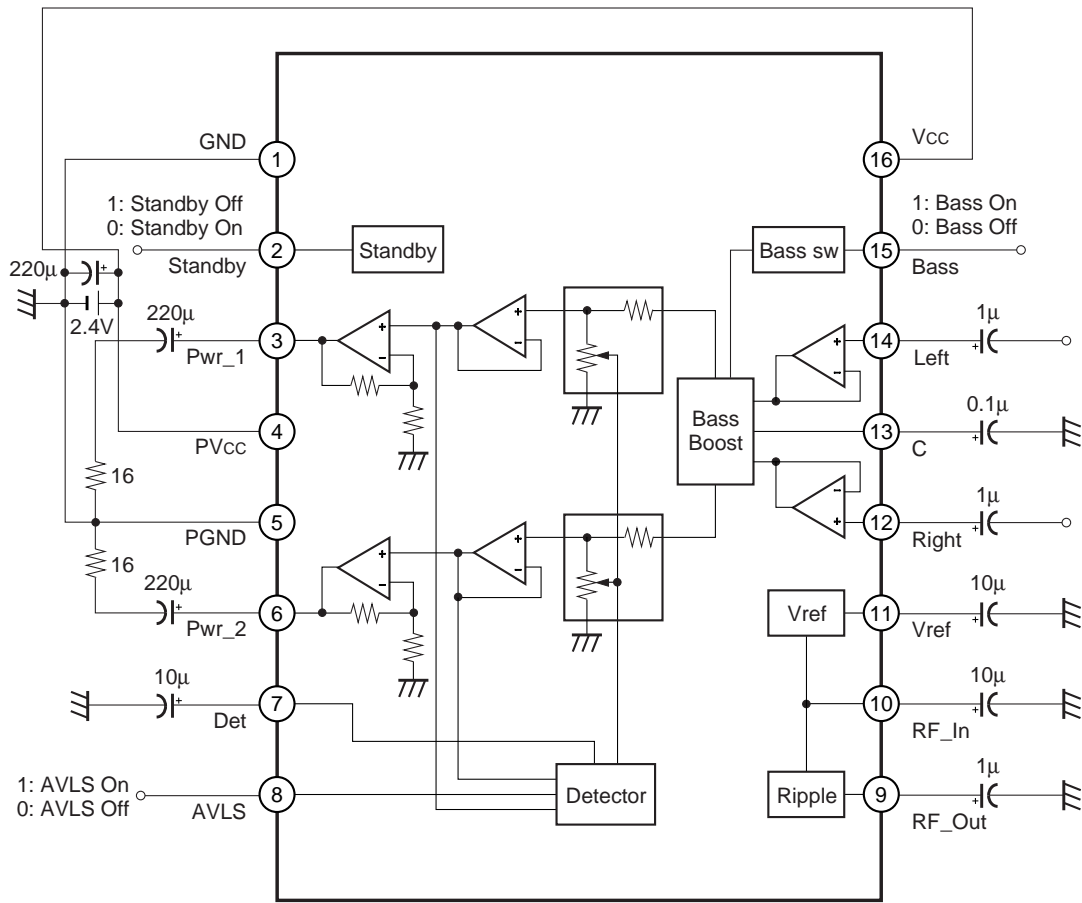

Application circuits shown are typical examples illustrating the operation of the devices. Sony cannot assume responsibility for any problems arising out of the use of these circuits or for any infringement of third party patent and other right due to same.

Example of Representative Characteristics

Circuit current (at no signal)

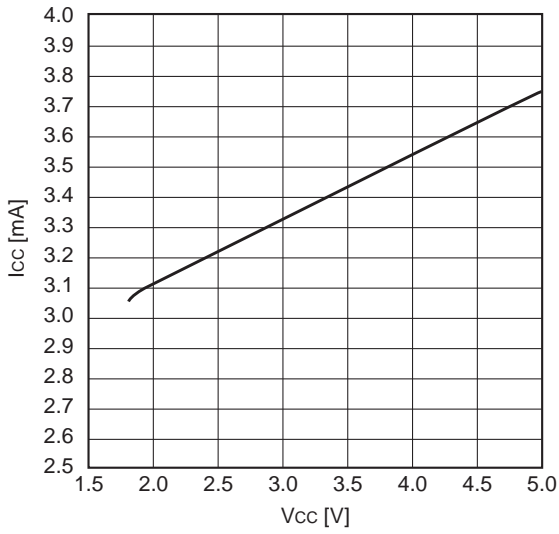

Frequency characteristic

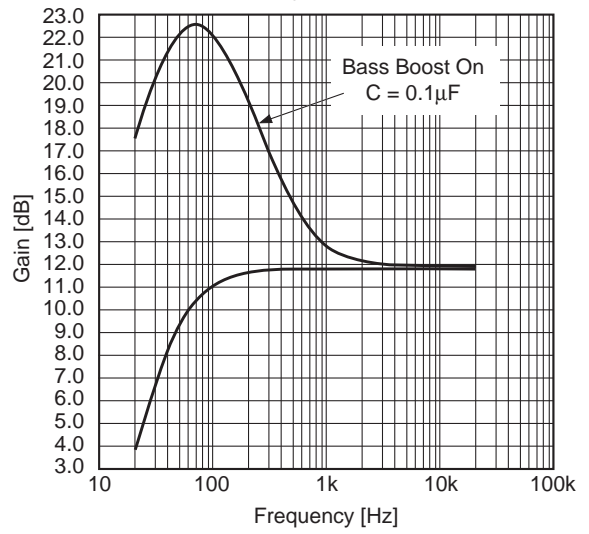

Crosstalk vs. Frequency

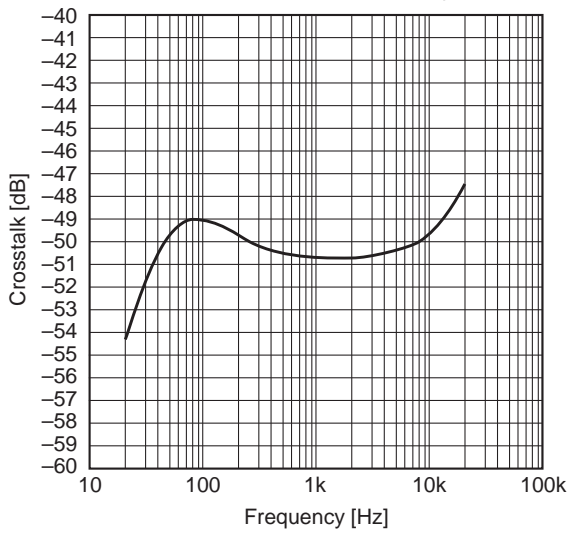

Distortion factor vs. Input characteristics

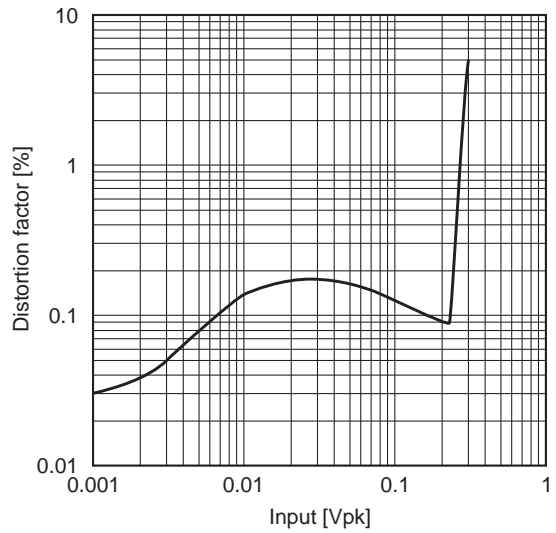

Package Outline

Unit: mm

16PIN SOP (PLASTIC)

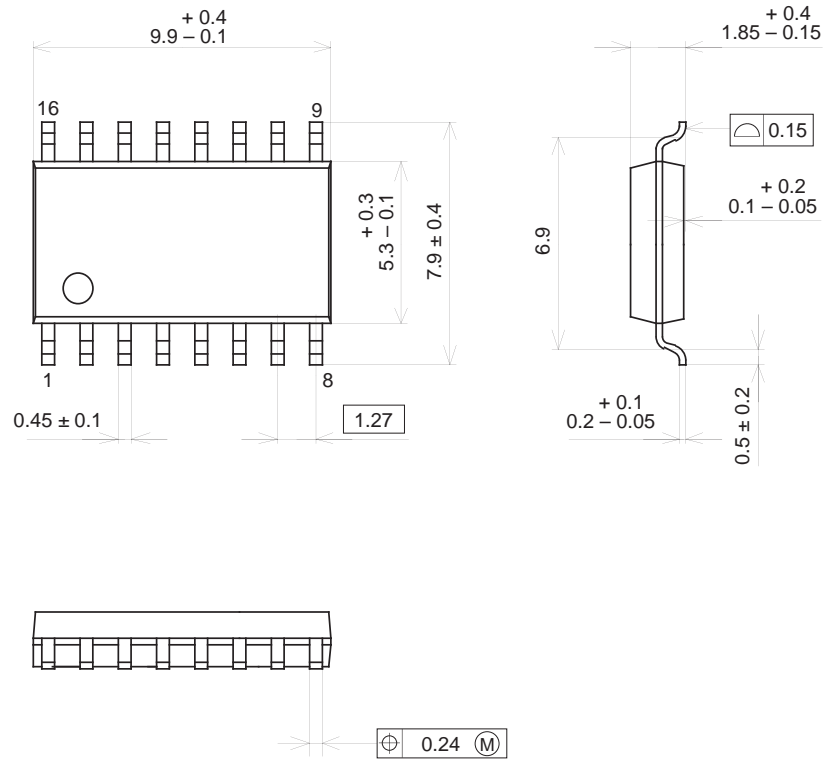

PACKAGE STRUCTURE

SONY CODE	SOP-16P-L01
EIAJ CODE	SOP016-P-0300
JEDEC CODE	_____

PACKAGE MATERIAL	EPOXY RESIN
LEAD TREATMENT	SOLDER PLATING
LEAD MATERIAL	COPPER ALLOY
PACKAGE MASS	0.2g



LittleDiode supplies new, hard to find or obsolete electronic components and semiconductors all over the world.

With over two million different components listed you are sure to find the part you need.

Feel free to visit us today at our online store:

LittleDiode.com

Looking forward to providing you with the best possible service.