

RF Matrix Amplifier

Description

The CXA2571N is an IC developed for the RF signal processing of compact disc players.

Features

- Wide band RF signal processing
- RF system VCA circuit
- RF system equalizer (supports CAV mode)
- Supports pickups with built-in RF summing amplifier
- Low power consumption mode (EQ Pass mode)
- RW/ROM switching mode
- Center error amplifier
- Output DC level shift circuit

Functions

- RFAC summing amplifier, equalizer, VCA
- RFDC summing amplifier
- Focus error amplifier
- Tracking error amplifier
- Automatic power control
- VC buffer amplifier (analog system, digital system)

Applications

CD-ROM/RW compatible systems

Structure

Bipolar silicon monolithic IC

30 pin SSOP (Plastic)

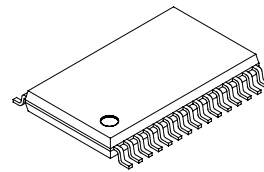

Absolute Maximum ratings

• Supply voltage	V _{CC}	7	V
• Operating temperature	T _{opr}	-20 to +75	°C
• Storage temperature	T _{stg}	-65 to +150	°C
• Allowable power dissipation	P _D	620	mW

Operating Conditions

• Supply voltage	V _{CC} – GND	3.0 to 5.5	V
• Operating temperature	T _{opr}	-20 to +75	°C

Sony reserves the right to change products and specifications without prior notice. This information does not convey any license by any implication or otherwise under any patents or other right. Application circuits shown, if any, are typical examples illustrating the operation of the devices. Sony cannot assume responsibility for any problems arising out of the use of these circuits.

Connected Circuit Diagram

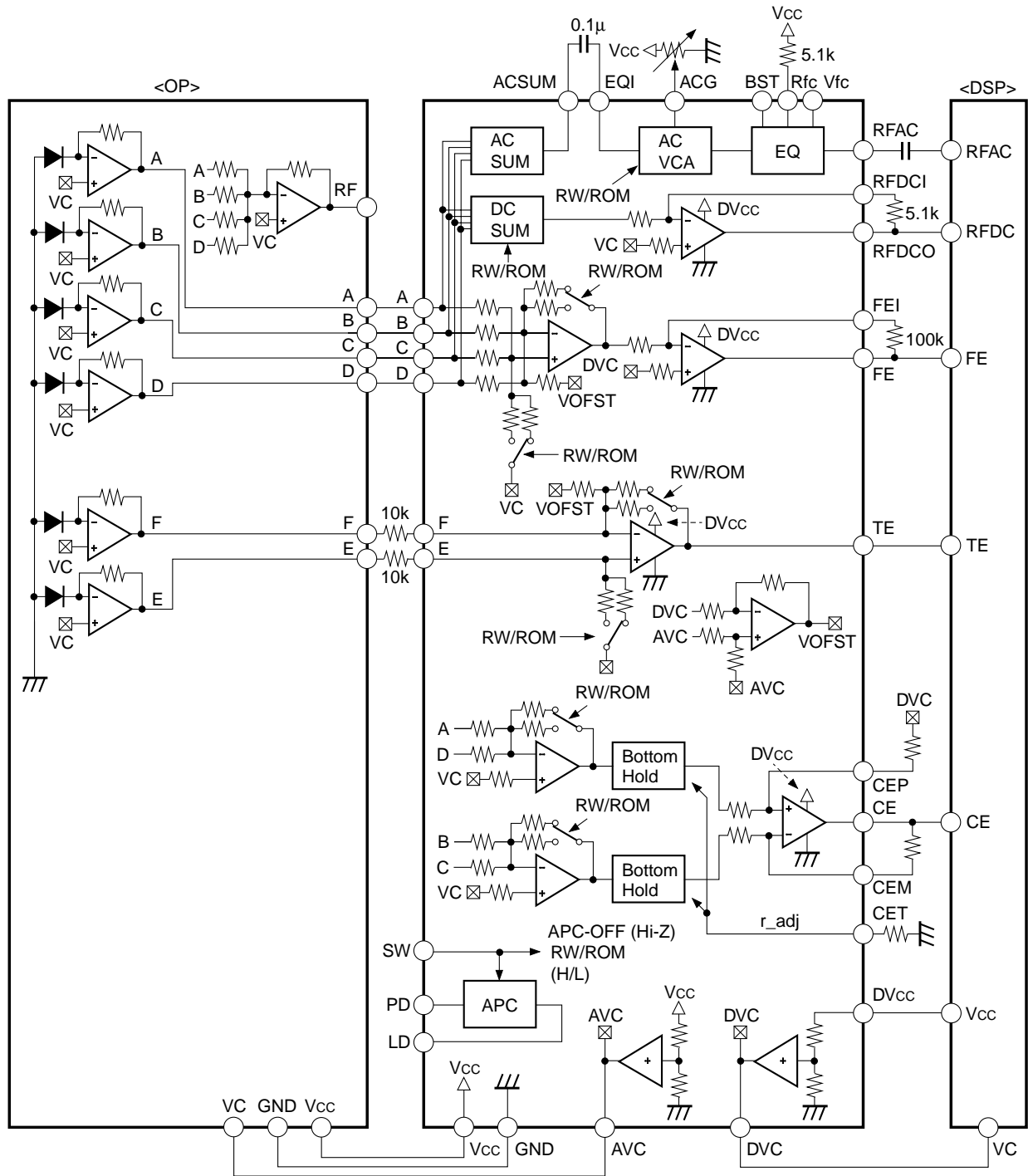

Pin Description

Pin NO.	Symbol	I/O	Description
1	LD	Out	APC amplifier output.
2	PD	In	APC amplifier input.
3	EQ_IN	In	RFAC system VCA block and EQ block input.
4	AC_SUM	Out	RFAC system RF SUM output.
5	GND	In	Ground.
6	A	In	A signal input.
7	B	In	B signal input.
8	C	In	C signal input.
9	D	In	D signal input.
10	E	In	E signal input.
11	F	In	F signal input.
12	SW	In	Mode switching signal input.
13	CET	In	CE system hold time constant adjustment.
14	CEP	—	CE amplifier non-inverted input.
15	DVcc	In	DVcc.
16	RFAC	Out	RFAC signal output.
17	DVC	Out	DVC output.
18	FE	Out	Focus error signal output.
19	FEI	—	FE amplifier virtual ground.
20	TE	Out	Tracking error signal output.
21	CE	Out	Center error signal output.
22	CEM	—	CE amplifier virtual ground.
23	Vcc	In	Vcc.
24	RFG	In	RFAC system VCA block low-frequency gain adjustment.
25	BST	In	EQ boost amount adjustment range.
26	VFC	In	EQ cut-off frequency adjustment.
27	RFC	In	EQ cut-off frequency adjustment.
28	VC	Out	VC voltage output.
29	RFDCO	Out	RFDC signal output.
30	RFDCI	—	RFDC amplifier virtual ground.

Pin Description and Equivalent Circuit

Pin No.	Symbol	I/O	Equivalent circuit	Description
1	LD	O		APC amplifier output.
2	PD	I		APC amplifier input.
3	EQ_IN	I		Equalizer circuit input.
4	AC_SUM	O		RFAC summing amplifier output.
5	GND	—	—	Ground.

Pin No.	Symbol	I/O	Equivalent circuit	Description
6	A	I		RF summing amplifier and focus error amplifier input.
7	B	I		
8	C	I		
9	D	I		
10	E	I		Tracking error amplifier input.
11	F	I		
20	TE	O		Tracking error amplifier output.
12	SW	I		CD-ROM/RW switching input. RW when connected to Vcc, ROM when connected to GND.
15	Vcc	—	—	Power supply.
16	RFAC	O		RFAC amplifier output.
17	DVC	O		(DVcc + GND)/2 voltage output.

Pin No.	Symbol	I/O	Equivalent circuit	Description
18	FE	O		Focus error amplifier output.
19	FEI	I		Focus error amplifier gain adjustment. The gain is adjusted by the external resistance value connected between this pin and Pin 18.
13	CET	I		Center error amplifier time constant adjustment.
14	CEP	I		Center error amplifier non-inverted input.
21	CE	O		Center error amplifier input.
22	CEM	I		Center error amplifier inverted input.
23	Vcc	—	—	Vcc. (AVcc)
24	RFG	I		Sets the RFAC low-frequency gain.
25	BST	I		Input for adjusting the equalizer circuit boost amount.
26	VFC	I		Input for adjusting the equalizer circuit boost frequency with the control voltage.

Pin No.	Symbol	I/O	Equivalent circuit	Description
27	RFC	I		Input for adjusting the equalizer circuit boost frequency with external resistance.
28	VC	O		(V _{CC} + GND)/2 voltage output.
29	RFDC	O		RFDC amplifier output. This pin serves as the eye pattern check point.
30	RFDCI	I		RFDC amplifier gain adjustment. The gain is adjusted by the external resistance value connected between this pin and Pin 29.

Electrical Characteristics Measurement Circuit

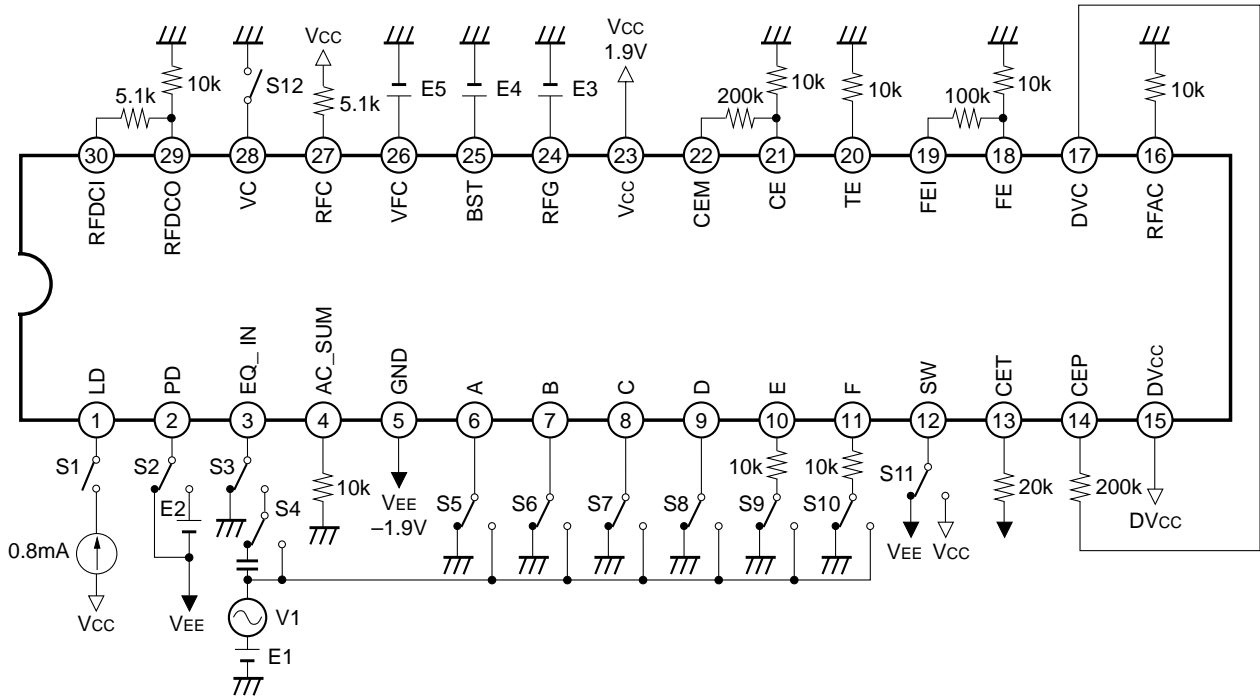

Application Circuits

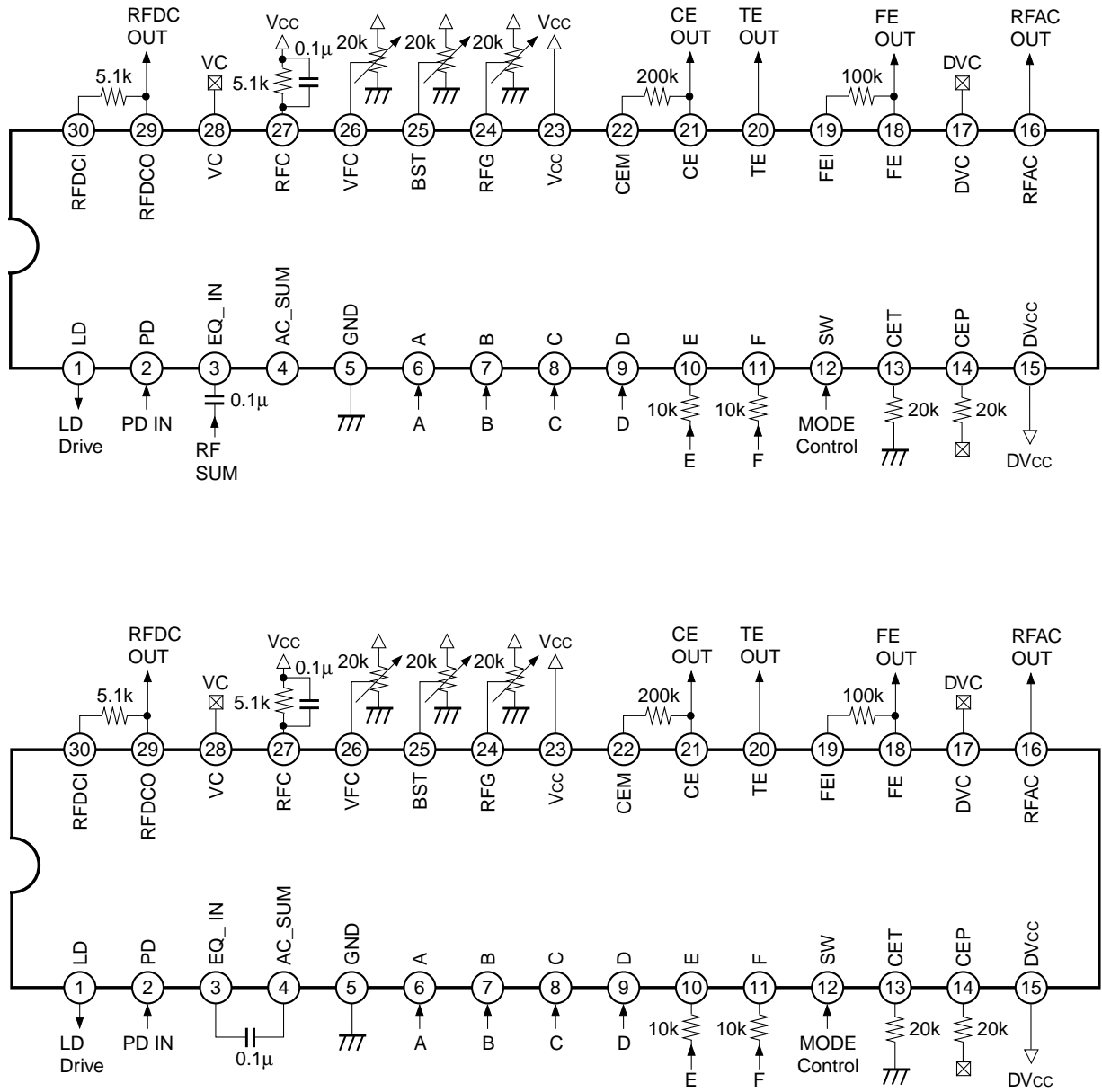

Application circuits shown are typical examples illustrating the operation of the devices. Sony cannot assume responsibility for any problems arising out of the use of these circuits or for any infringement of third party patent and other right due to same.

Description of Functions

• **RFAC**

The RF signal input by connecting capacitance to the EQ_IN pin is equalized, arithmetically amplified and then output from the RFAC pin.

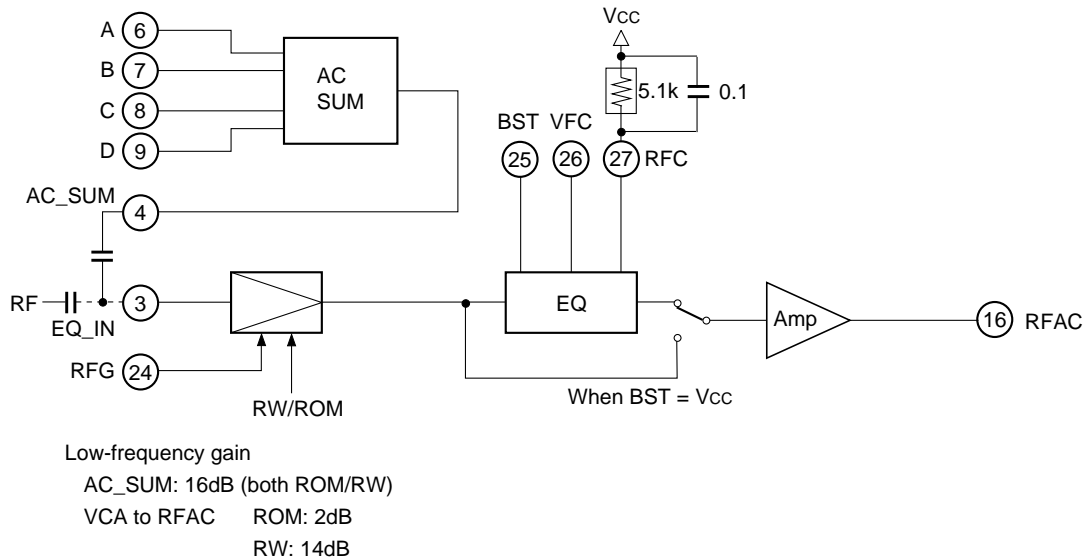

The EQ can be bypassed by connecting the BST control pin (Pin 25) to Vcc. In this case only the EQ block enters sleep mode and the low power consumption mode (slim mode) is activated. The low-frequency gain is the same value as for EQ ON mode.

The RF_SUM input dynamic range is $VC \pm 300mV$ (typ.).

If RF (summing signal) is present at the pickup output pin, input the addition output signal to the EQ_IN pin (Pin 3) coupled by capacitance.

When using a pickup without a summing output function, perform addition with the AC SUM block and then input the signal to the EQ_IN pin coupled by capacitance.

RW/ROM switching is done by the VCA block, so either input method can be used without problem.

The RW gain is 12dB higher than the ROM gain.

The VCA low-frequency gain can be adjusted by the RFG pin (Pin 24) voltage.

The control voltage vs. low-frequency gain characteristics are shown in the graph to the right.

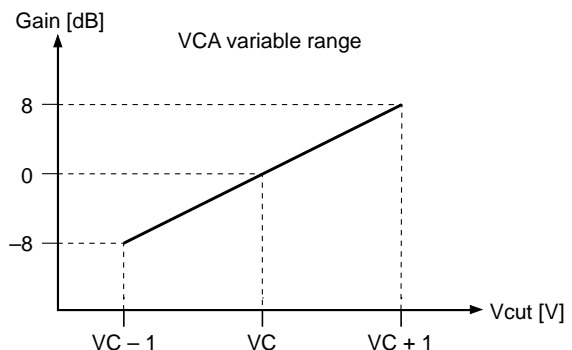

The RFAC pin (Pin 16) is an NPN transistor emitter follower output.

The maximum drive current is approximately 2mA.

If the load capacitance distorts the output waveform, increase the drive current.

Connect resistance between Pin 16 and GND.

• EQ

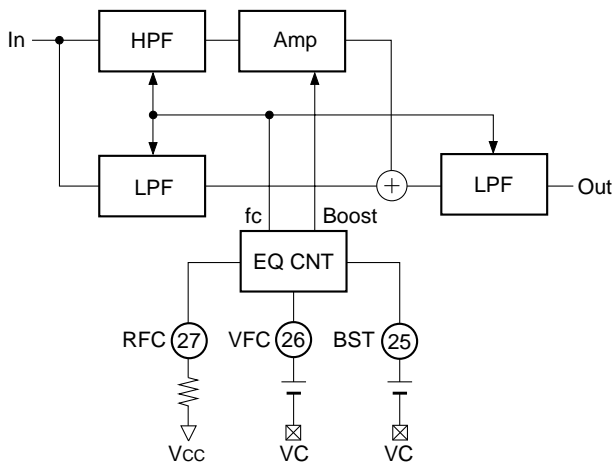

The diagram to the left shows the EQ internal block diagram.

The EQ consists of a combination of HPF and LPF. The HPF and LPF transmittance is the Bessel function. The boost gain can be adjusted by adjusting the HPF gain.

The boost frequency is adjusted by the RFC external resistance value and the VFC control voltage value.

RFC resistance value: The cut-off frequency f_0 of each filter is adjusted by the Pin 27 external resistance value. The VFC voltage can be varied using this f_0 as the reference.

VFC voltage: f_0 can be changed by the voltage applied to Pin 26.

The boost gain can be adjusted by the BST pin control voltage. The control characteristics are shown in the graph below.

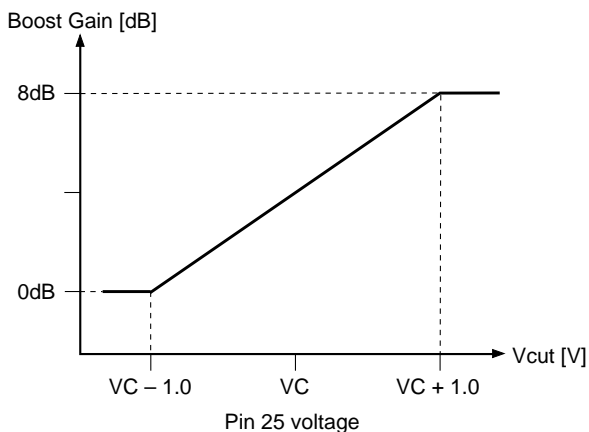

The cut-off frequency control characteristics are shown in the graph below.

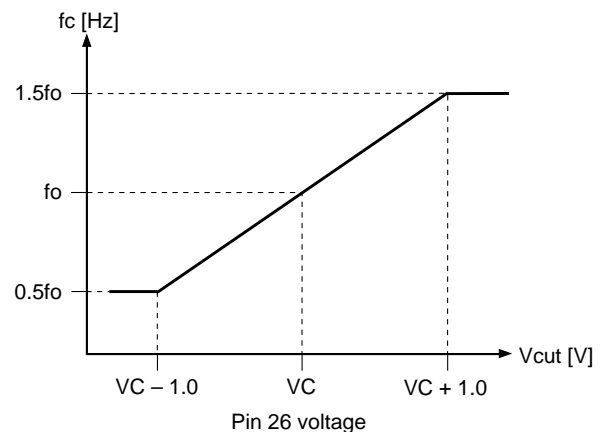

• APC (Automatic Power Control)

When the laser diode is driven by a constant current, the optical power output has extremely large negative temperature characteristics. Therefore, the current must be controlled to maintain the monitor photodiode output at a constant level. This control is performed by the APC function.

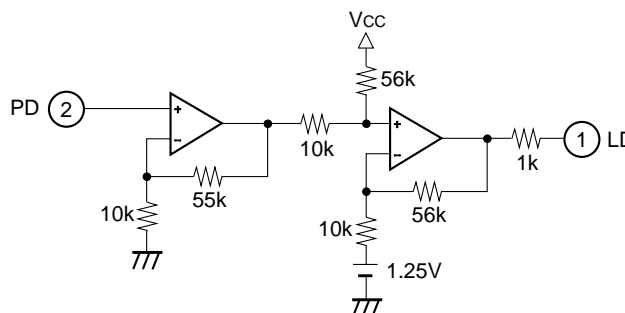

• Focus Error

The signals input to the A and C pins and the B and D pins are arithmetically amplified and the focus error signal is output.

This circuit has RW/ROM switching, low-frequency gain adjustment and offset addition functions.

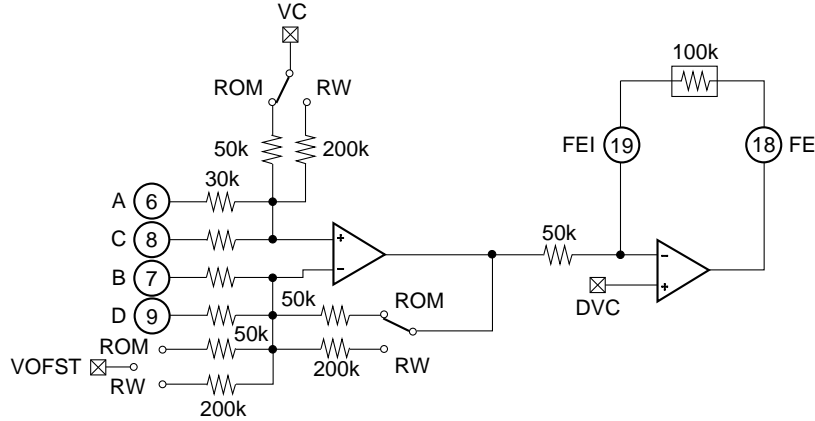

FE = Gain { (B + D) - (A + C) }

Low-frequency gain ROM: 16dB
 RW: 28dB

Cut-off frequency fc (typ.) ROM: 400kHz
 RW: 300kHz

• Tracking Error

The signals input to the E and F pins are arithmetically amplified and the tracking error signal is output.

This circuit has RW/ROM switching and offset addition functions.

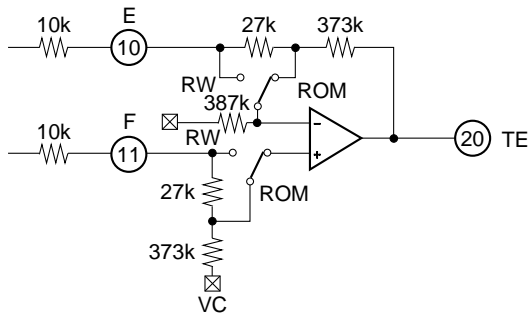

TE = Gain (F - E)

Low-frequency gain ROM: 20dB
 RW: 32dB

fc (typ.) ROM: 1MHz
 RW: 250kHz

• VC Buffer

This outputs the VC ((1/2) Vcc) voltage. The maximum output current is approximately ±3mA. Use this voltage as the analog system VC voltage.

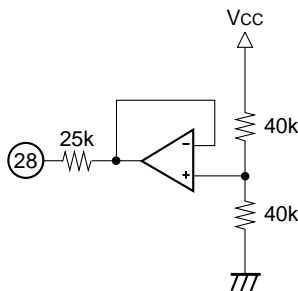

• DVC Buffer

This outputs the 1/2 DVcc voltage. The maximum output current is approximately ±3mA. Use this voltage as the digital system DC voltage. The output DC voltage of each system is level shifted using the DVC voltage as the reference.

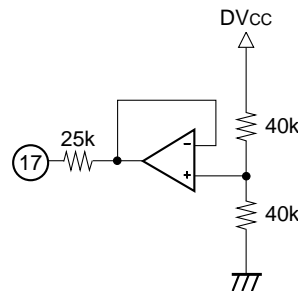

• RFDC

The signals input via the A, B, C and D pins are added, amplified and the RFDC signal is output. RW/ROM switching and low-frequency gain adjustment are possible.

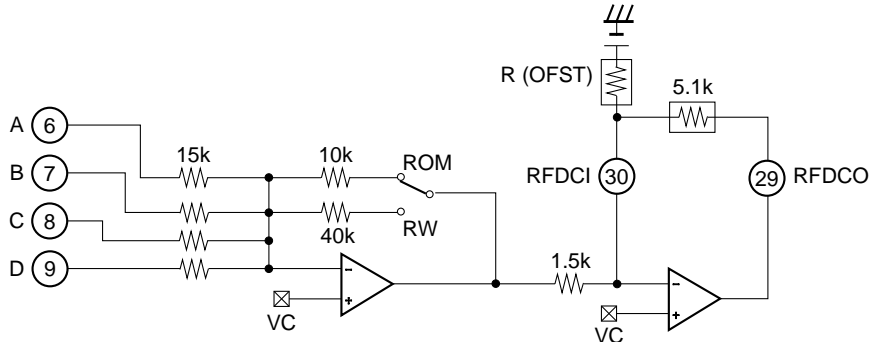

RFDC = Gain (A + B + C + D)
 Low-frequency gain ROM: 20dB (17MHz)
 RW: 32dB (5.5MHz)
 fc (Typ.) ROM: 12MHz
 RW: 5MHz

The gain can be adjusted by the external resistance connected between Pins 29 and 30.
 The output voltage offset can be adjusted by the R (OFST) resistance.

• Center Error

The signals input to the A and D pins and the B and C pins are arithmetically amplified and the center error signal is output.

RW/ROM switching, low-frequency gain adjustment and offset adjustment are possible.

The bottom hold time constant can be adjusted by the CET (Pin 13) external resistance value.

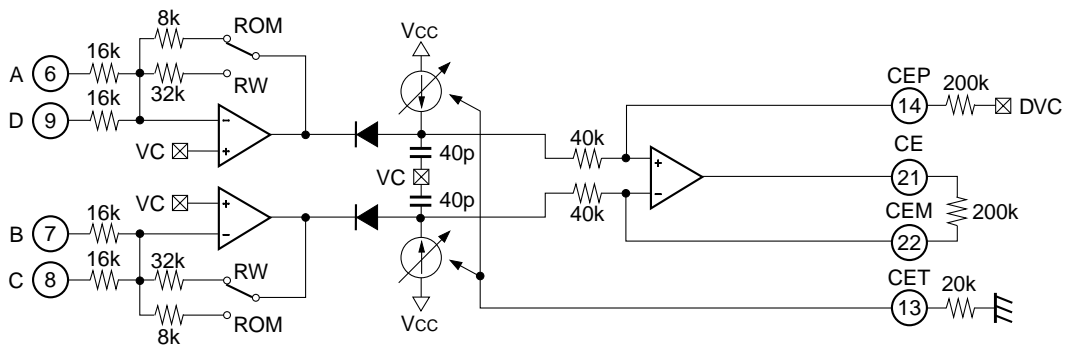

The (B + C) – (A + D) signal is arithmetically amplified.
 Low-frequency gain ROM: 14dB
 RW: 26dB

• Output Offset Shift

The RFDC, FE, TE and CE output DC voltages are level shifted to the digital VC voltage (DVC). The reference voltage of this IC is the VC voltage, and only the output reference voltage changes. The maximum output voltage of each output signal should be kept to the digital V_{CC} voltage (DV_{CC}) or less in order to protect the DSP_IC.

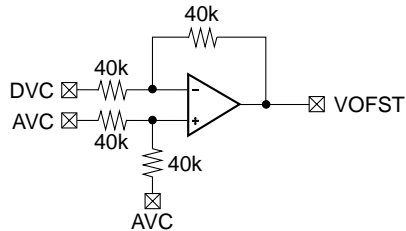

The AVC and DVC voltages are arithmetically amplified and output as the VOFST voltage.

The VOFST voltage serves as the level shift reference voltage, and is distributed to each system.

• SW

This controls the laser (APC) on/off, active/sleep mode, and RW/ROM mode switching. Switching is controlled by the voltage applied to the SW pin (Pin 12).

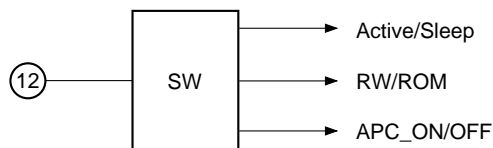

The VC buffer is kept active even in sleep mode. In the function block, BGR and MODE_SW are always set to active mode.

Control voltage \ Item	APC	Active/Sleep	RW/ROM
V _{CC}	ON	Active	RW
VC or Hi-Z	OFF	Sleep	—
GND	ON	Active	ROM

Notes on Operation

[RFAC signal]

Stabilizing the RFAC signal

The RFAC system (RFSUM + EQ) is comprised entirely of non-inverted function blocks.

This is in order to support pickups with built-in RFSUM.

Therefore, if the voltage gain of each block is increased, a feedback loop is formed over the entire RFAC system causing the RFAC signal to become unstable (oscillate).

In these cases, it is recommended to lower the EQ frequency response and the boost gain. This has a large effect on the board (power supply, I/O signal cross talk, etc.) loop. The RFAC signal easily becomes unstable if the VCA gain is increased, the EQ boost frequency is set to a high frequency, the EQ boost amount is increased, etc.

The VCA gain is low in ROM mode, so the RFAC signal is stable.

The area where the RFAC signal becomes unstable is thought to vary for each set, as this is greatly affected by the board loop as noted above.

Proposed stabilization measures

The board and other loop characteristics can be changed by adding external capacitance as noted below.

This has a particularly large effect on the stabilization when using RFSUM.

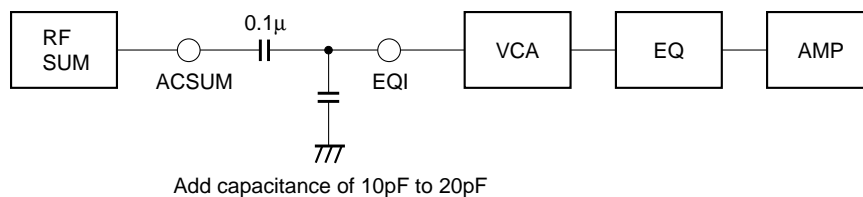

[Limiter circuit]

This IC has a limiter circuit to protect the input range of the rear-end IC (DSP) during excessive voltage output for each signal (RFDC, FE, TE, CE).

When the limiter circuit operates, the maximum output voltage is limited to the DV_{CC} voltage or less.

However, when limiting the excessive voltage output, the ON/OFF operation of the limiter circuit causes the maximum output side (clipped portion of the output waveform) to oscillate slightly.

Example) AV_{CC} = 5V, DV_{CC} = 3V

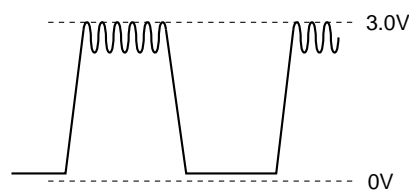

Example of Representative Characteristics

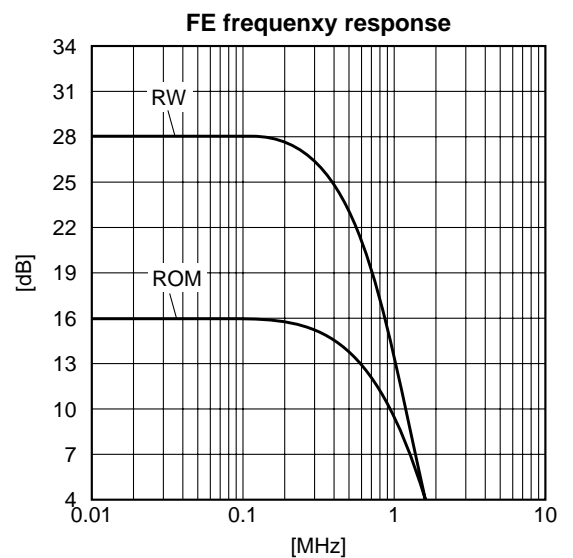
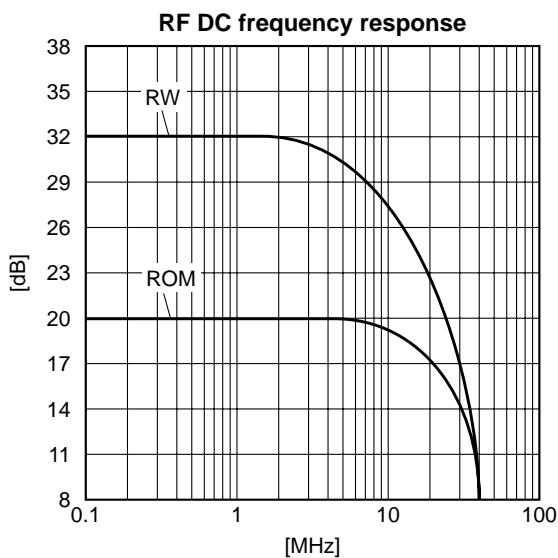
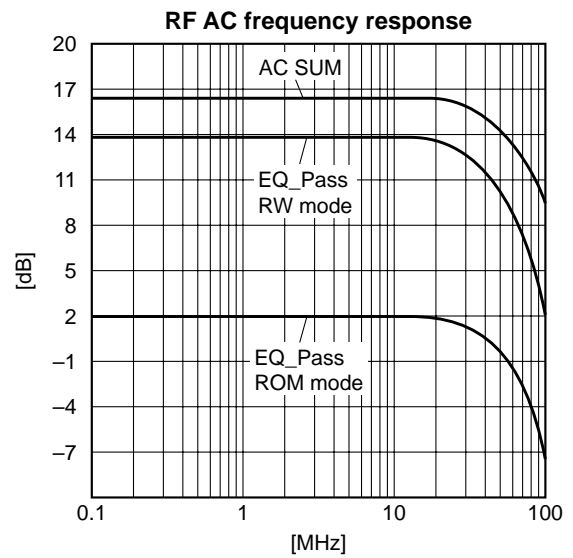
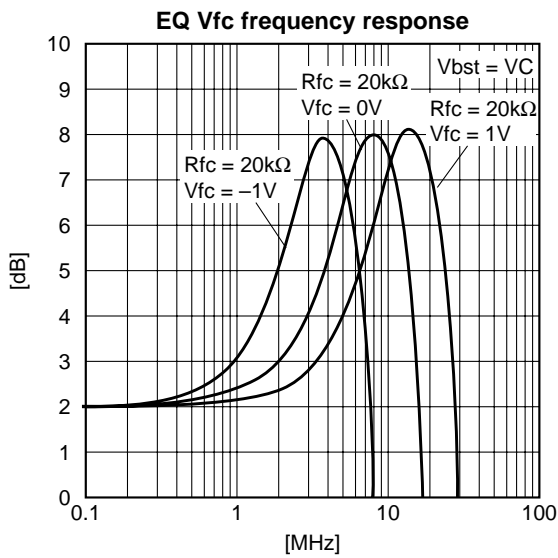
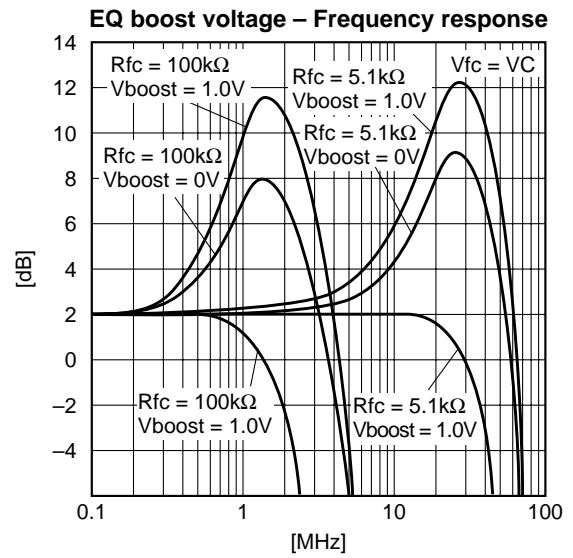
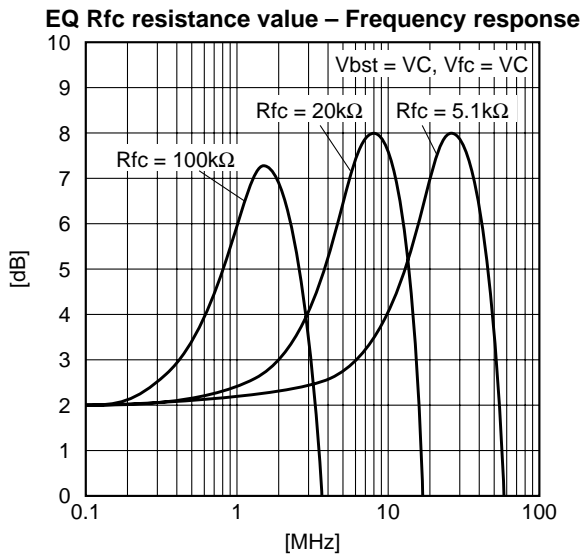

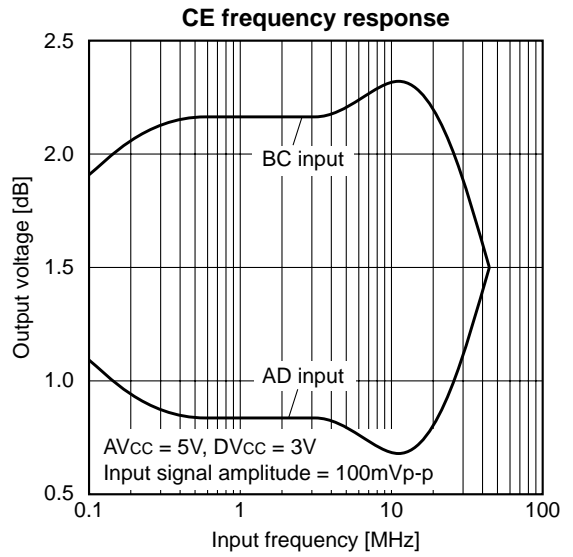
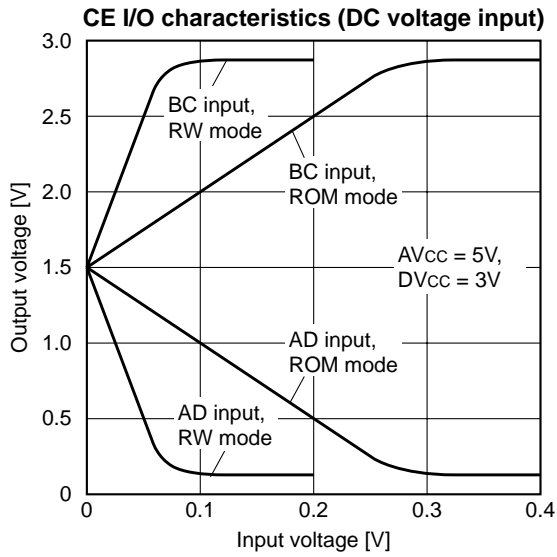
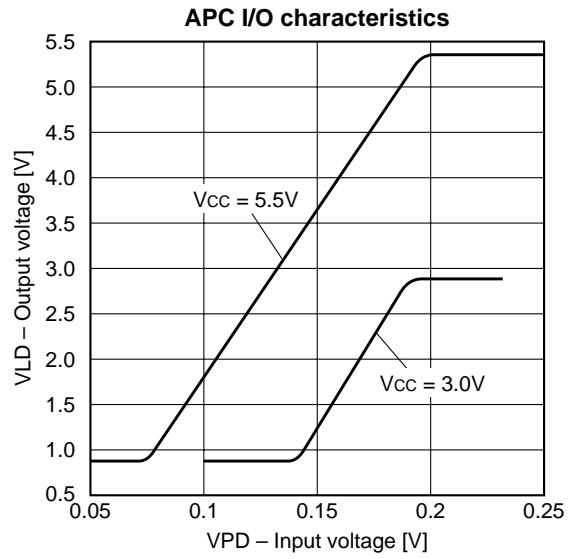
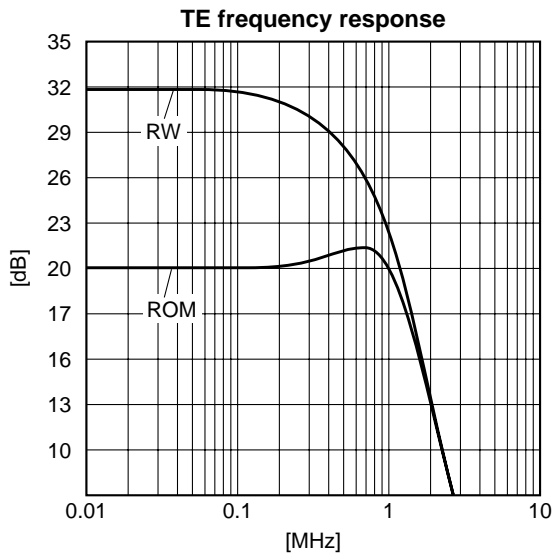

Package Outline Unit: mm

30PIN SSOP (PLASTIC)

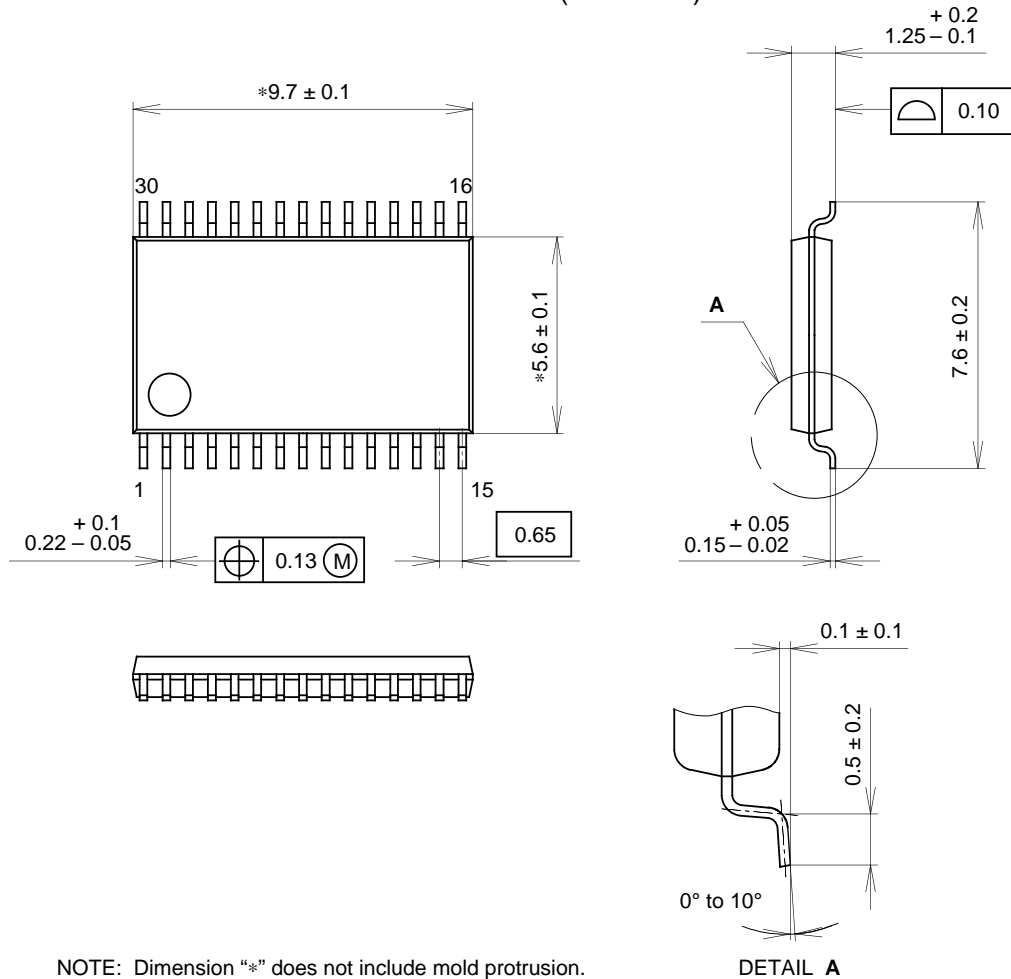

NOTE: Dimension "*" does not include mold protrusion.

PACKAGE STRUCTURE

SONY CODE	SSOP-30P-L01
EIAJ CODE	SSOP030-P-0056
JEDEC CODE	_____

PACKAGE MATERIAL	EPOXY RESIN
LEAD TREATMENT	SOLDER/PALLADIUM PLATING
LEAD MATERIAL	42/COPPER ALLOY
PACKAGE MASS	0.1g

NOTE : PALLADIUM PLATING
 This product uses S-PdPPF (Sony Spec.-Palladium Pre-Plated Lead Frame).



LittleDiode supplies new, hard to find or obsolete electronic components and semiconductors all over the world.

With over two million different components listed you are sure to find the part you need.

Feel free to visit us today at our online store:

LittleDiode.com

Looking forward to providing you with the best possible service.