

UHF-Band RF Modulator for VCR

Description

The CXA3219M is a UHF-band RF modulator which converts the frequency of audio and video signals. Some circuits which comprise this IC are a UHF oscillator video clamp, white clip, video modulator, audio FM modulator and an intercarrier SW.

Features

- Low voltage of 5V
- Wide bandwidth 470 to 750MHz
- UHF oscillator greatly reduces external parts
- Sharp white clip circuit
- Built-in voltage regulator can accept large fluctuation of supply voltage
- Video input of 0.5Vp-p for general-purpose use
- Mixer simplifies RF unit design
- Picture/sound ratio is adjustable with external parts
- Intercarrier switch

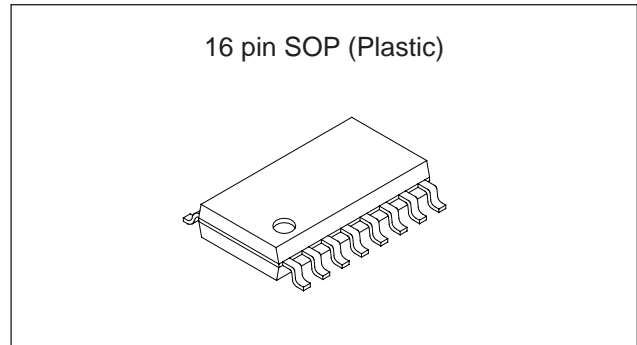

Applications

PAL system VCR

Absolute Maximum Ratings

• Supply voltage	V _{cc}	7	V
• Operating temperature	T _{opr}	-20 to +75	°C
• Storage temperature	T _{stg}	-55 to +150	°C
• Allowable power dissipation	P _d	350	mW

Structure

Bipolar silicon monolithic IC

Recommended Supply Voltage Range

Supply voltage	V _{cc}	5.0 ± 0.5	V
----------------	-----------------	-----------	---

Block Diagram and Pin Configuration

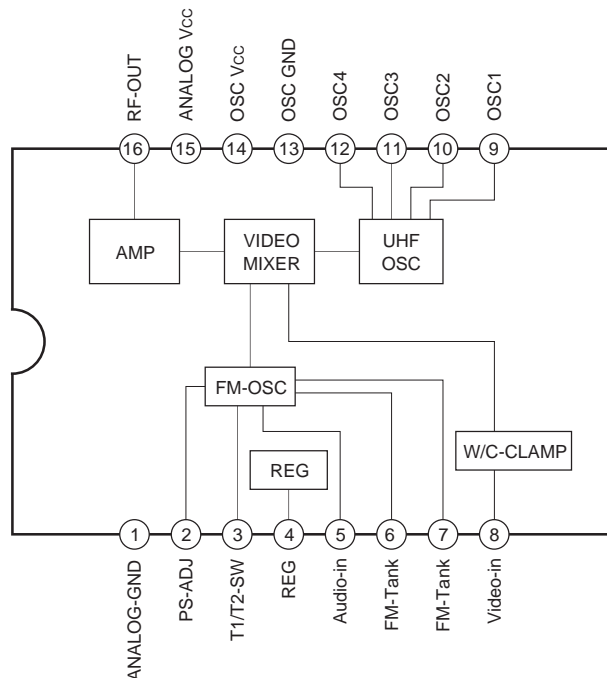

Sony reserves the right to change products and specifications without prior notice. This information does not convey any license by any implication or otherwise under any patents or other right. Application circuits shown, if any, are typical examples illustrating the operation of the devices. Sony cannot assume responsibility for any problems arising out of the use of these circuits.

Pin Description and Equivalent Circuit

Pin No.	Symbol	Typical pin voltage [V]	Equivalent circuit	Description
1	GND1			GND for RF/audio.
2	P/S ADJ	1.8		P/S adjustment (Adding a capacitor between Pin 2 and GND increases P/S ratio.) Video modulation depth adjustment (Adding a resistor between Pin 2 and GND increases the modulation depth; adding a resistor between Pins 2 and 4 decreases the modulation depth.)
3	T1/T2 SW	2.4		T1/T2 SW. T1 for GND. T2 for OPEN.
4	REG OUT	4.1		Regulator output.
5	AUDIO IN	0		Audio input.
6	TANK1	3.1		5.5MHz audio tank coil connection.

Pin No.	Symbol	Typical pin voltage [V]	Equivalent circuit	Description
7	TANK2	2.9		6.0MHz audio tank coil connection.
8	VIDEO IN	2.6		Video input.
9 10 11 12	OSC1 OSC2 OSC3 OSC4	2.5 1.7 1.7 2.5		Oscillator pin.
13	GND2			GND for oscillator.
14	Vcc1			Power supply for oscillator.
15	Vcc2			Power supply for RF/audio.
16	RF OUT	4.1		RF output.

Electrical Characteristics 1

Refer to Electrical Characteristics Test Circuit. (Ta = 25°C, Vcc = 5V, fP = 591.25MHz)

Item	Symbol	Conditions	Min.	Typ.	Max.	Unit	
Supply current	Icc	V ₁ (VIDEO IN) and V ₂ (AUDIO IN) at no signal	22	28	35	mA	
Video output level	Vo	*1	78.7	81.2	83.7	dBμV	
Video modulation depth	mp	V ₁ = 0.5Vp-p, FLAT FIELD signal input	72	78.5	86	%	
Max. video modulation depth (During limiter operation)	mp (Max.)	V ₁ = 1.0Vp-p, FLAT FIELD signal input	92	95.5	99	%	
Chroma beat	Vcb	V ₁ = 4.43MHz, 0.5Vp-p sine wave input*5	68	78	–	dB	
Sync crush level	ΔSync	V ₁ = 0.5Vp-p, FLAT FIELD signal input ΔSync = (1 – S/W · 10/4) × 100	–	2	5	%	
Differential gain	DG	STAIR STEP signal input V ₁ = 0.5Vp-p*2	0	1.6	5	%	
Differential phase	DP	STAIR STEP signal input V ₁ = 0.5Vp-p*2	–5	0	5	deg	
Video 2nd-harmonic wave ratio	V _{VH}	V ₁ = 0.5Vp-p, 1MHz sine wave input*3	48	52.5	–	dB	
PS ratio	Vps	V ₁ = no input, fs = 5.5MHz	11.5	14	16.5	dB	
Audio FM modulation sensitivity	βS1 (T1)	V ₂ = 100mVp-p, 1kHz sine wave input fs frequency change/0.1V*6	fs = 5.5MHz	0.400	0.420	0.455	kHz/mV
	βS2 (T2)		fs = 6.0MHz	0.380	0.400	0.440	
Audio distortion	THD	V ₂ = 1kHz sine wave input*4	0	0.4	1	%	
Audio S/N ratio	ASN	V ₂ = 1kHz sine wave input 0dB at fs = 5.5MHz with 60kHz deviation V ₁ = STAIR STEP signal input (rms measurement)	45	54	–	dB	
Max. audio FM modulation depth	ms (Max.)	V ₂ = 1Vp-p, 1kHz sine wave input (T1) fs frequency change (kHz)/100kHz × 100	380	415	–	%	
Audio 2nd-harmonic wave ratio	V _{S2}	Difference between video carrier (V ₁ = no input) and 2nd-harmonic wave, at PS ratio of 14dB conversion	52	57	–	dB	

Electrical Characteristics 2

1. Video S/N	50dB (min.), 58dB (typ.)
2. Video amplitude frequency characteristics (at 1MHz reference)	Within ± 1 dB at 0.5 to 5MHz
3. APL variation (Normalized to APL 50%)	Within $\pm 2\%$ at 10 to 90%
4. Pin 5 input impedance	1M Ω and above
5. Pin 8 input impedance	1M Ω and above

- *1 Spectrum analyzer with 50 Ω input impedance should be used to test video output level. Measured value V_o (dBm) is used to calculate output according to the following relationship:

$$\text{Output (dB}\mu\text{)} = V_o \text{ (dBm)} + 107 \quad \text{50}\Omega \text{ terminal direct reading value}$$
- *2 Measured after demodulating by standard demodulator.
- *3 $f_c + 2$ MHz component of V_1 carrier (f_c) level.
- *4 Adjust the V_2 level to obtain an FM deviation of ± 30 kHz and measure the harmonic distortion after demodulating V_o with a standard demodulator.
- *5 Video determined by measuring ratio (dB) of chroma beat to video carrier level when $V_1 =$ no signal by spectrum analyzer.
- *6 R1 (12k Ω) of the Electrical Characteristics Test Circuit is added for obtaining a better match between the audio modulation sensitivity classifications and the actual pre-emphasis.

Input Waveform

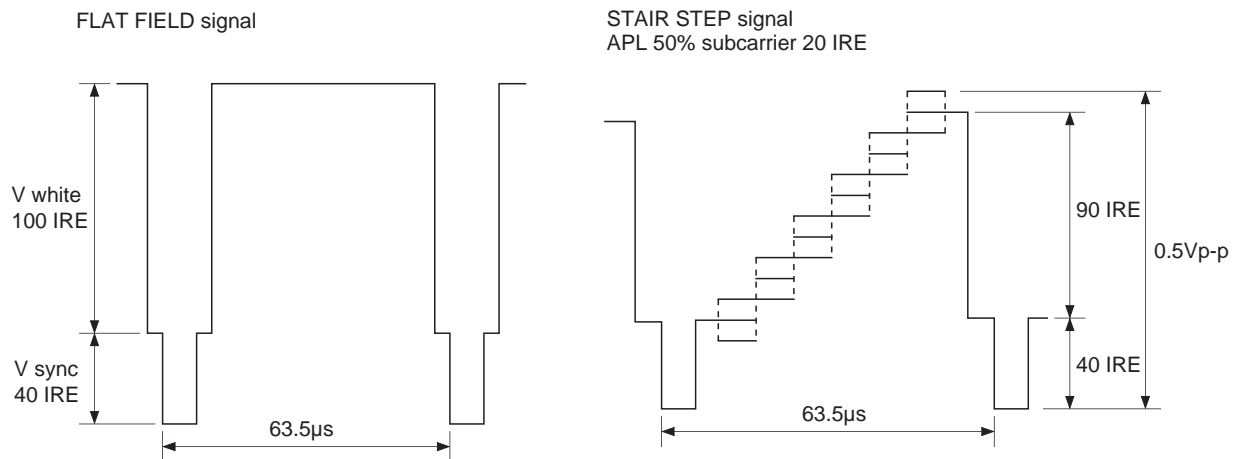

Electrical Characteristics Test Circuit

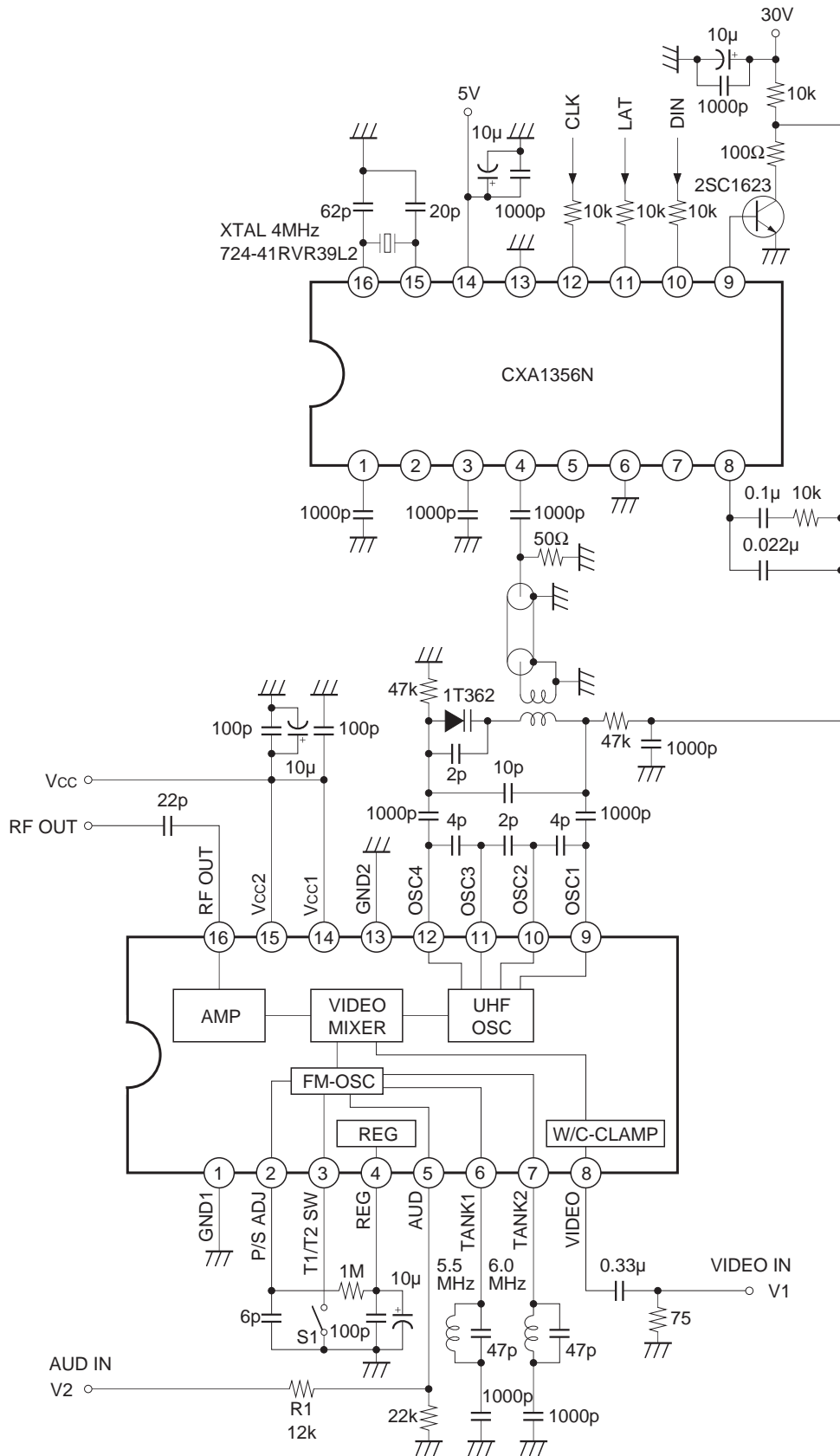

Application Circuit 1

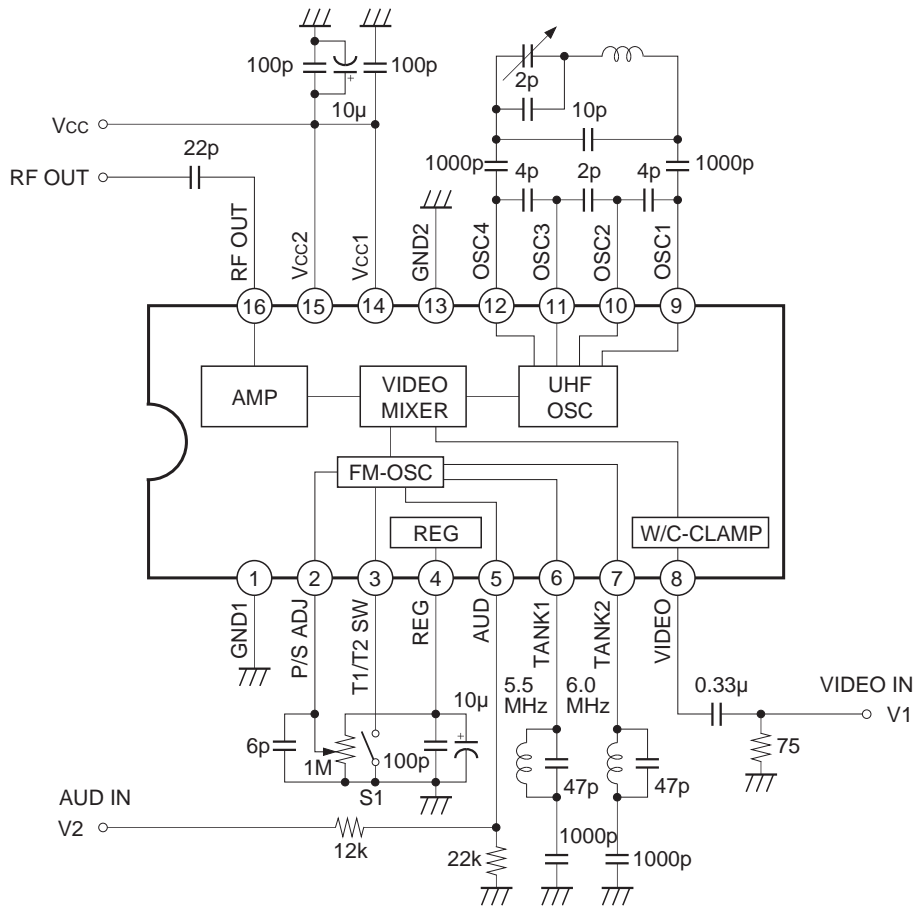

Application circuits shown are typical examples illustrating the operation of the devices. Sony cannot assume responsibility for any problems arising out of the use of these circuits or for any infringement of third party patent and other right due to same.

Application Circuit 2

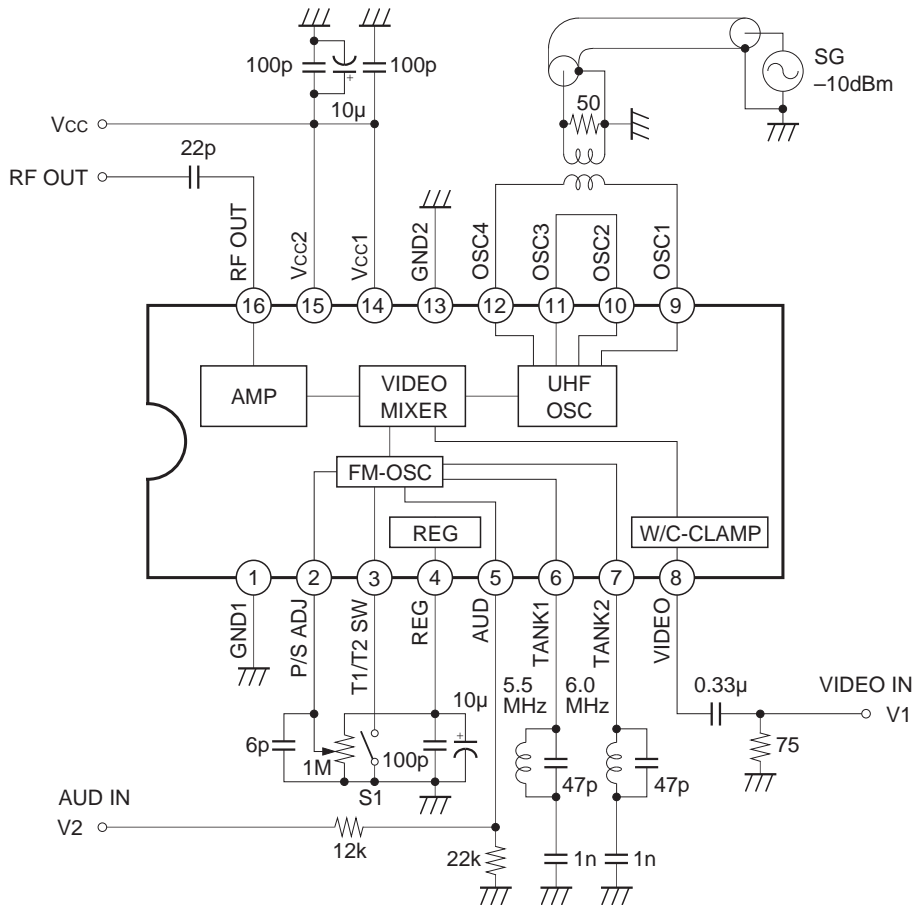

Application circuits shown are typical examples illustrating the operation of the devices. Sony cannot assume responsibility for any problems arising out of the use of these circuits or for any infringement of third party patent and other right due to same.

Example of Representative Characteristics

Supply voltage vs. Video output level

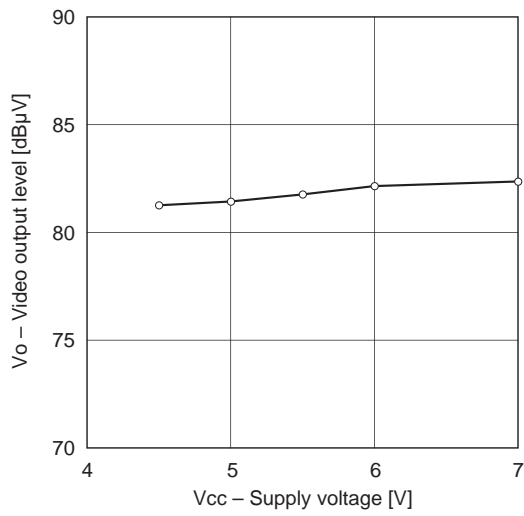

Supply voltage vs. Video modulation depth

(fp = 591.25MHz, Ta = 25°C)

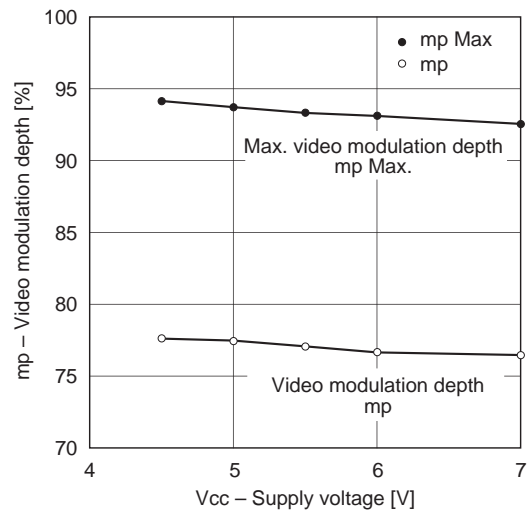

Supply voltage vs. PS ratio

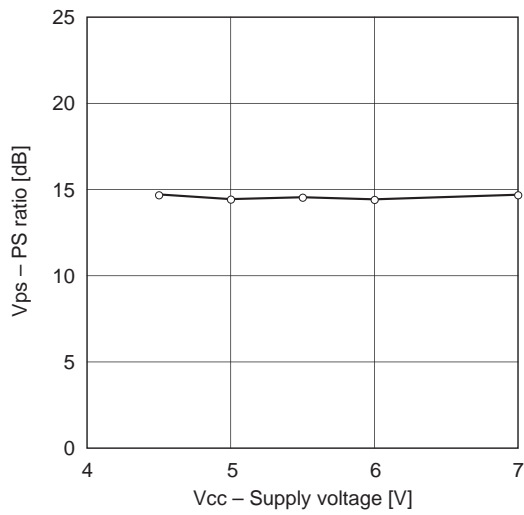

Supply voltage vs. Audio FM modulation sensitivity

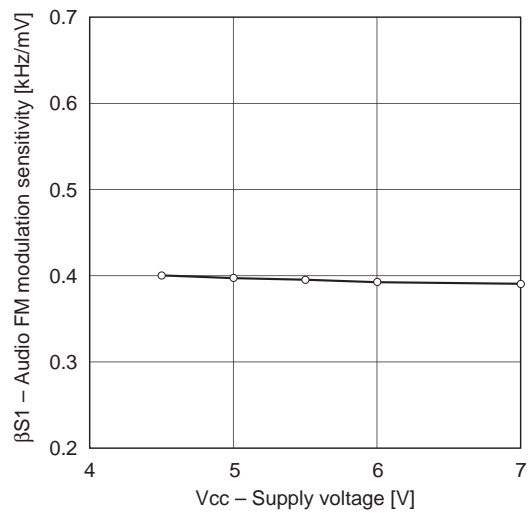

Ambient temperature vs. Video output level

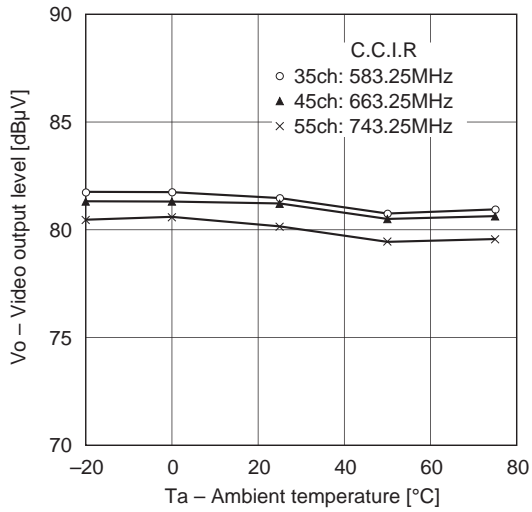

Ambient temperature vs. Video modulation depth

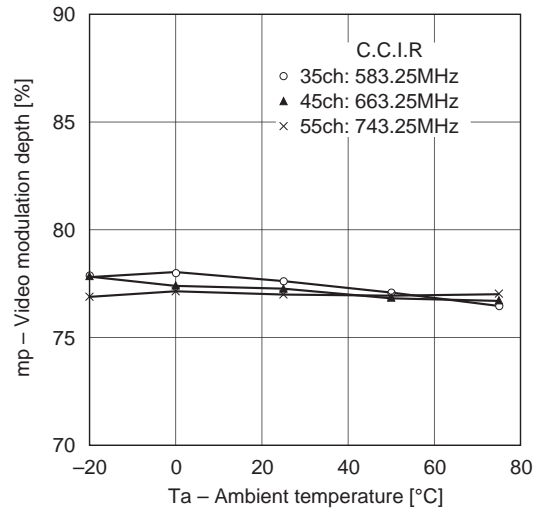

Ambient temperature vs. Max. video modulation dep

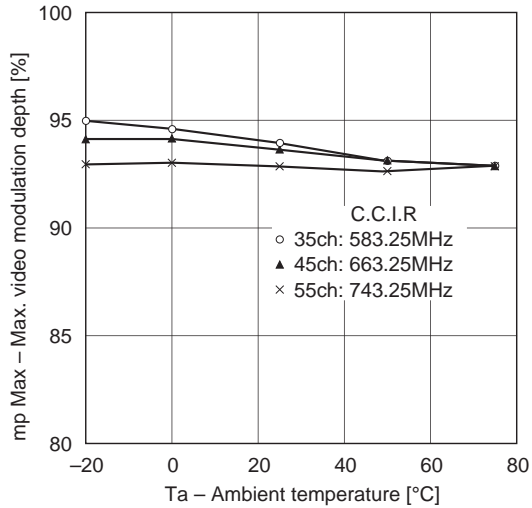

Ambient temperature vs. PS ratio

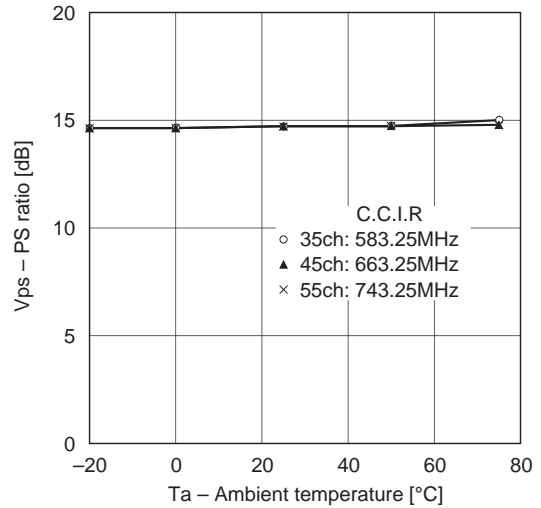

Ambient temperature vs. Audio 2nd-harmonic wave ratio

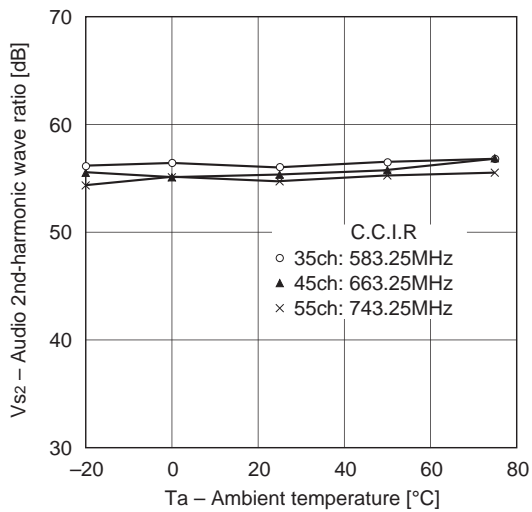

Ambient temperature vs. Video 2nd-harmonic wave ratio

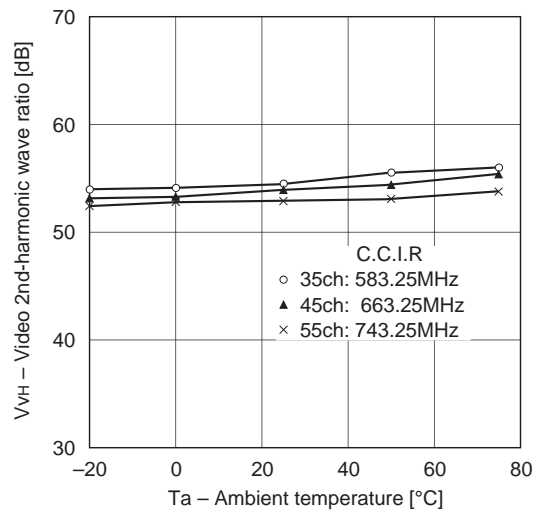

Ambient temperature vs. Chroma beat

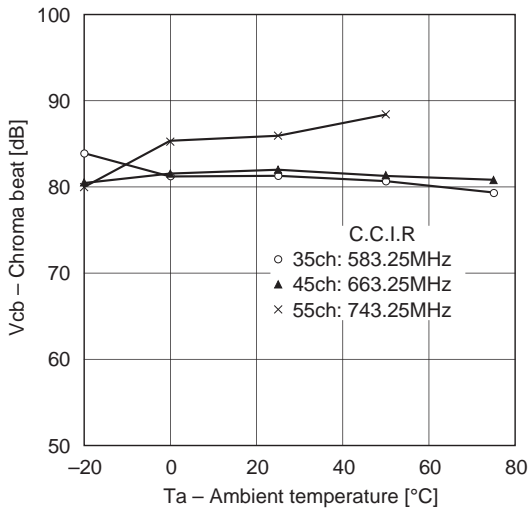

Ambient temperature vs. Differential gain

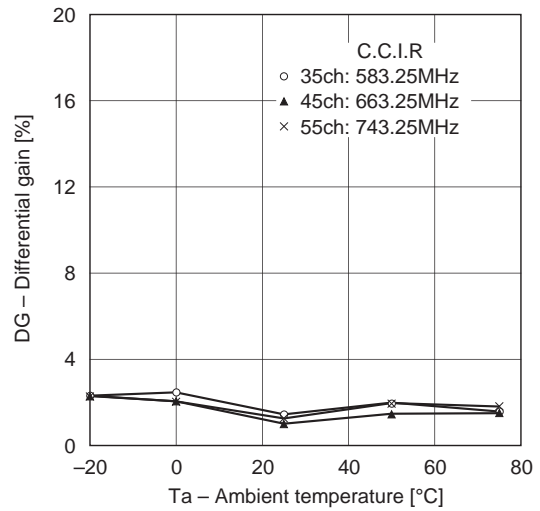

Ambient temperature vs. Differential phase

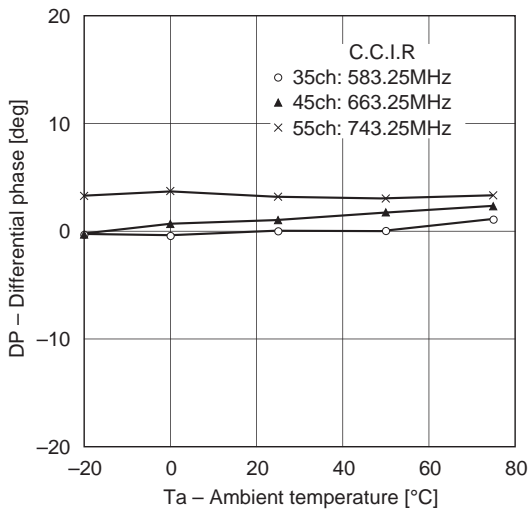

Ambient temperature vs. Audio distortion

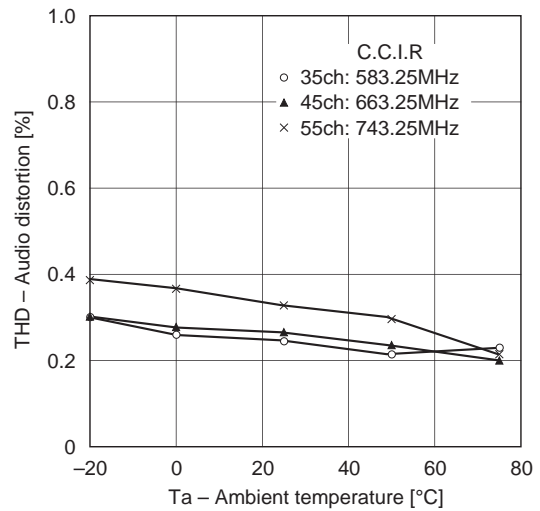

Ambient temperature vs. Audio S/N ratio

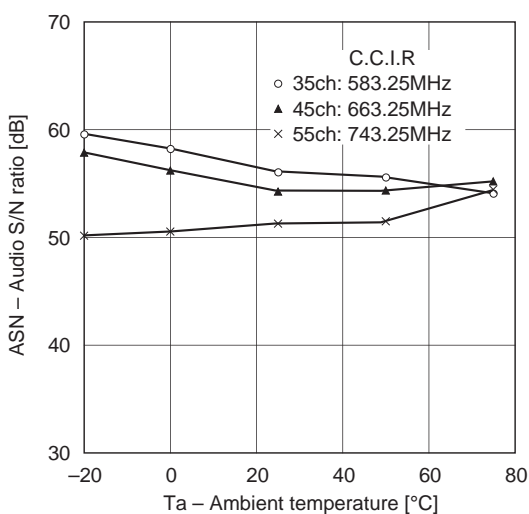

Ambient temperature vs. Sync crush level

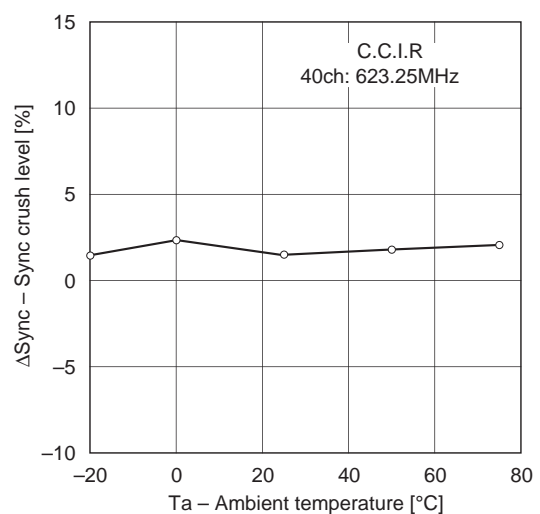

Ambient temperature vs. Audio FM modulation sensitivity

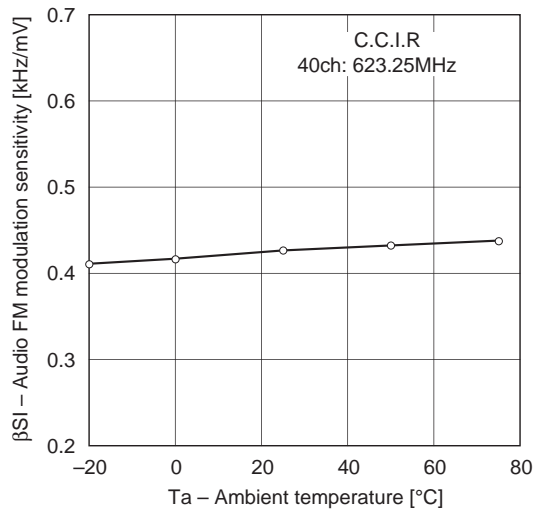

Ambient temperature vs. Max. audio FM modulation depth

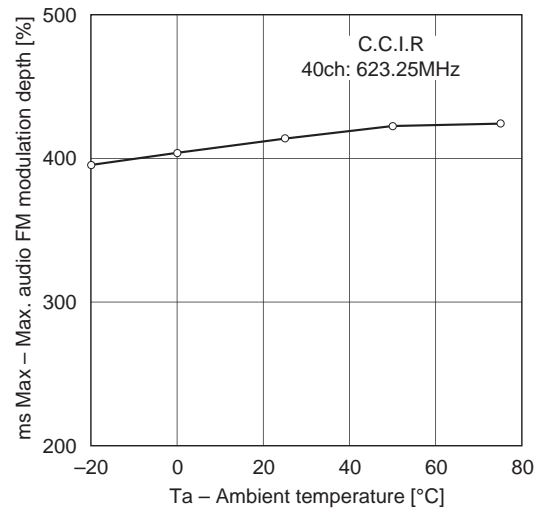

Video carrier frequency vs. Video output level

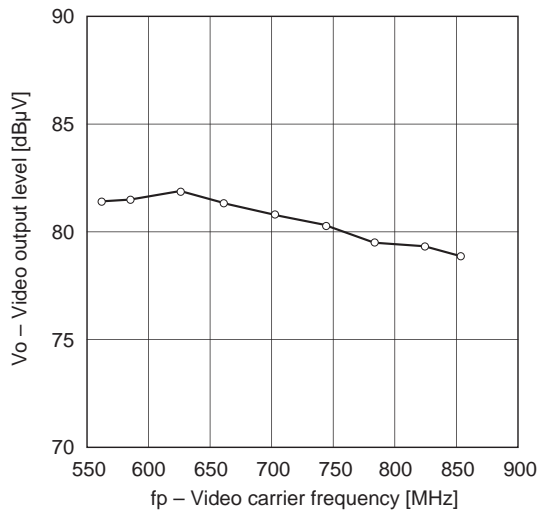

Video carrier frequency vs. Video modulation depth

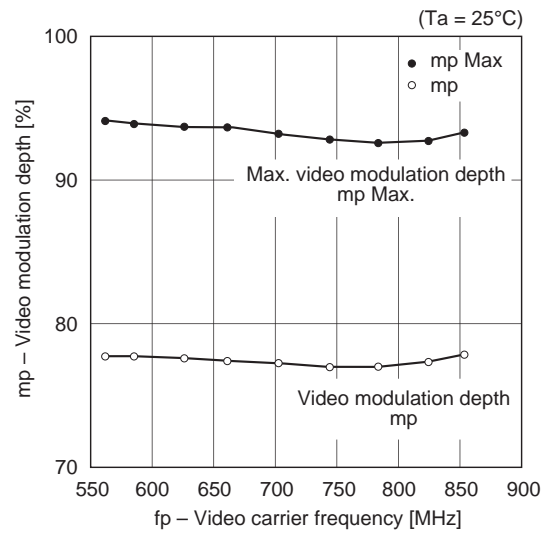

Video carrier frequency vs. PS ratio

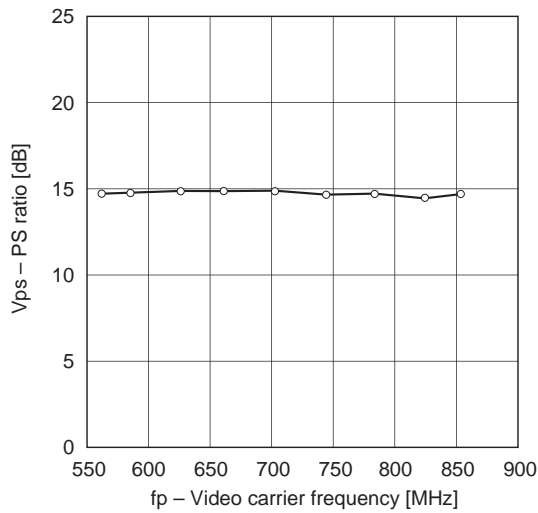

Video carrier frequency vs. Audio 2nd-harmonic wave ratio

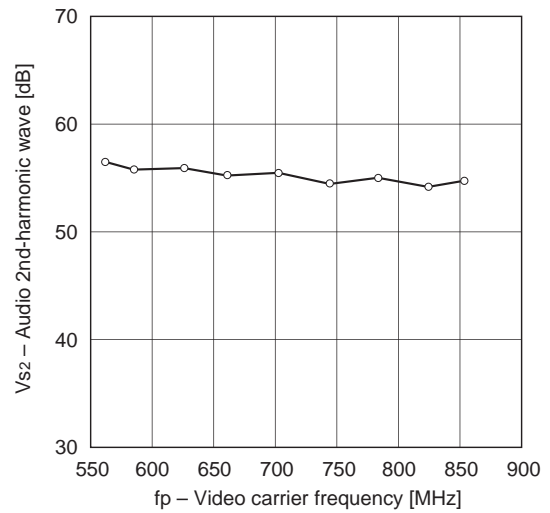

Video carrier frequency vs. Video 2nd-harmonic wave ratio

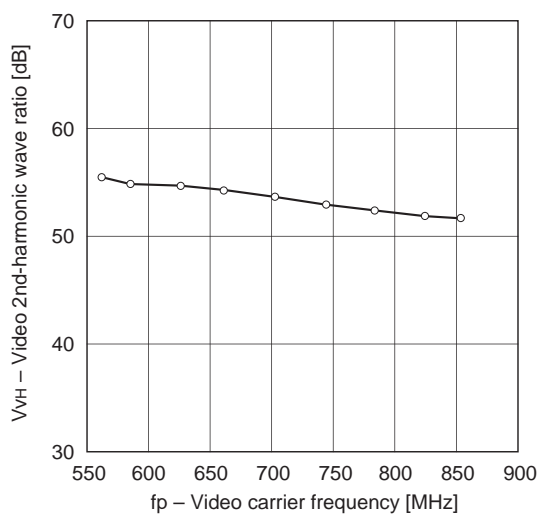

Video carrier frequency vs. Chroma beat

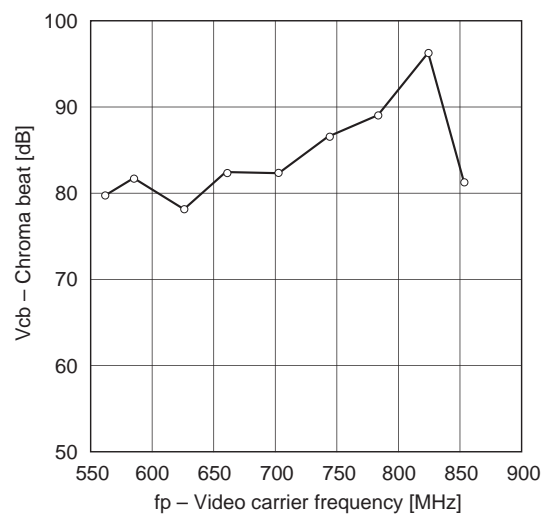

Video carrier frequency vs. Audio distortion

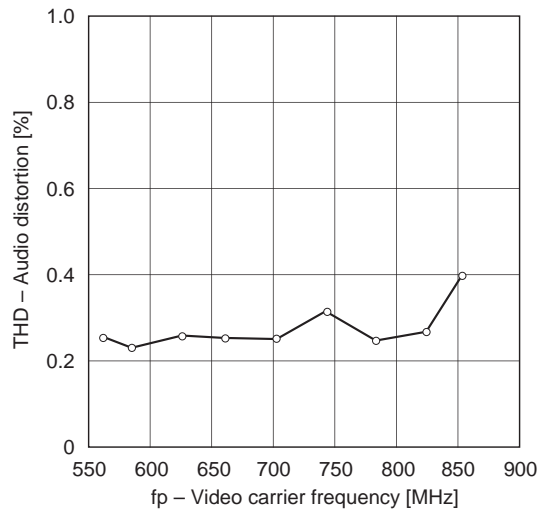

Video carrier frequency vs. Audio S/N ratio

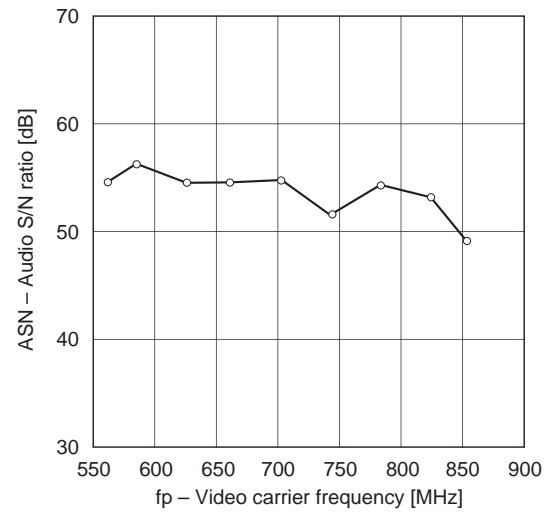

Video carrier frequency vs. Differential gain

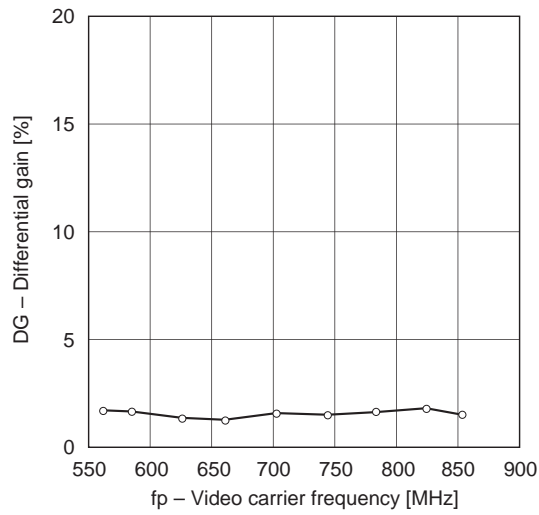

Video carrier frequency vs. Differential phase

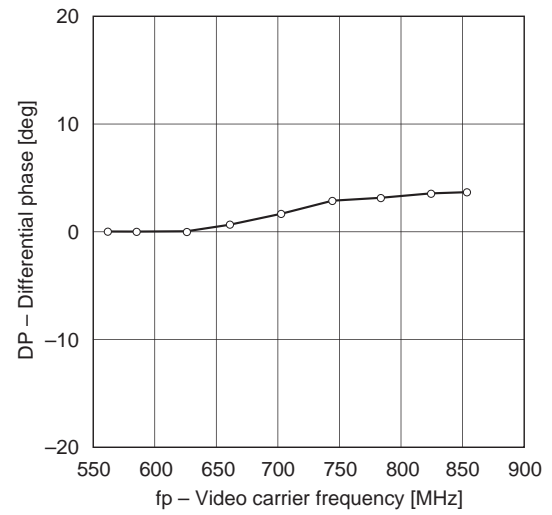

Package Outline

Unit: mm

16PIN SOP (PLASTIC) 300mil

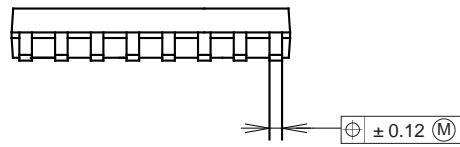
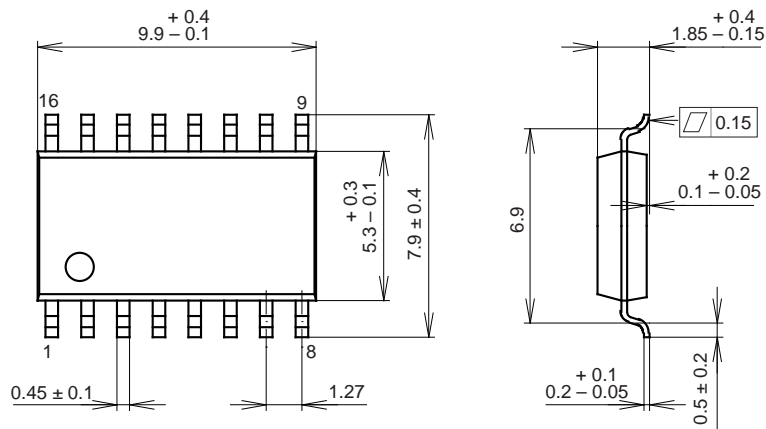

SONY CODE	SOP-16P-L01
EIAJ CODE	*SOP016-P-0300-A
JEDEC CODE	_____

PACKAGE STRUCTURE

PACKAGE MATERIAL	EPOXY RESIN
LEAD TREATMENT	SOLDER PLATING
LEAD MATERIAL	COPPER ALLOY
PACKAGE WEIGHT	0.2g



LittleDiode supplies new, hard to find or obsolete electronic components and semiconductors all over the world.

With over two million different components listed you are sure to find the part you need.

Feel free to visit us today at our online store:

LittleDiode.com

Looking forward to providing you with the best possible service.