

## 8-bit 40MSPS High Speed D/A Converter

**Description**

The CXD1171M is a 8-bit 40 MHz high speed D/A converter. The adoption of a current output system reduces power consumption to 80 mW (200  $\Omega$  load at 2 Vp-p output).

This IC is suitable for digital TV and graphic display applications.

**Features**

- Resolution 8-bit
- Max. conversion speed 40MSPS
- Non linearity error within  $\pm 0.25$  LSB
- Low glitch noise
- TTL CMOS compatible input
- +5 V single power supply
- Low power consumption 80 mW (200  $\Omega$  load at 2 Vp-p output)

**Function**

8-bit 40 MHz D/A converter

**Structure**

Silicon gate CMOS IC

24 pin SOP (Plastic)

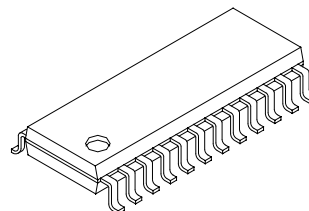
**Absolute Maximum Ratings** (Ta=25 °C)

- Supply voltage AVDD, DVDD 7 V
- Input voltage (All pins)
 

VIN	VDD +0.5 to VSS -0.5 V
-----	------------------------
- Output current IOUT 15 mA
- Storage temperature
 

Tstg	-55 to +150 °C
------	----------------

**Recommended Operating Conditions**

- Supply voltage AVDD, AVSS 4.75 to 5.25 V
- DVDD, DVSS 4.75 to 5.25 V
- Reference input voltage
 

VREF	2.0 V
------	-------
- Clock pulse width
 

Tpw1, Tpw0	11.2 ns (min) to 1.1 $\mu$ s (max)
------------	------------------------------------
- Operating temperature
 

Topr	-40 to +85 °C
------	---------------

Sony reserves the right to change products and specifications without prior notice. This information does not convey any license by any implication or otherwise under any patents or other right. Application circuits shown, if any, are typical examples illustrating the operation of the devices. Sony cannot assume responsibility for any problems arising out of the use of these circuits.

Block Diagram and Pin Configuration

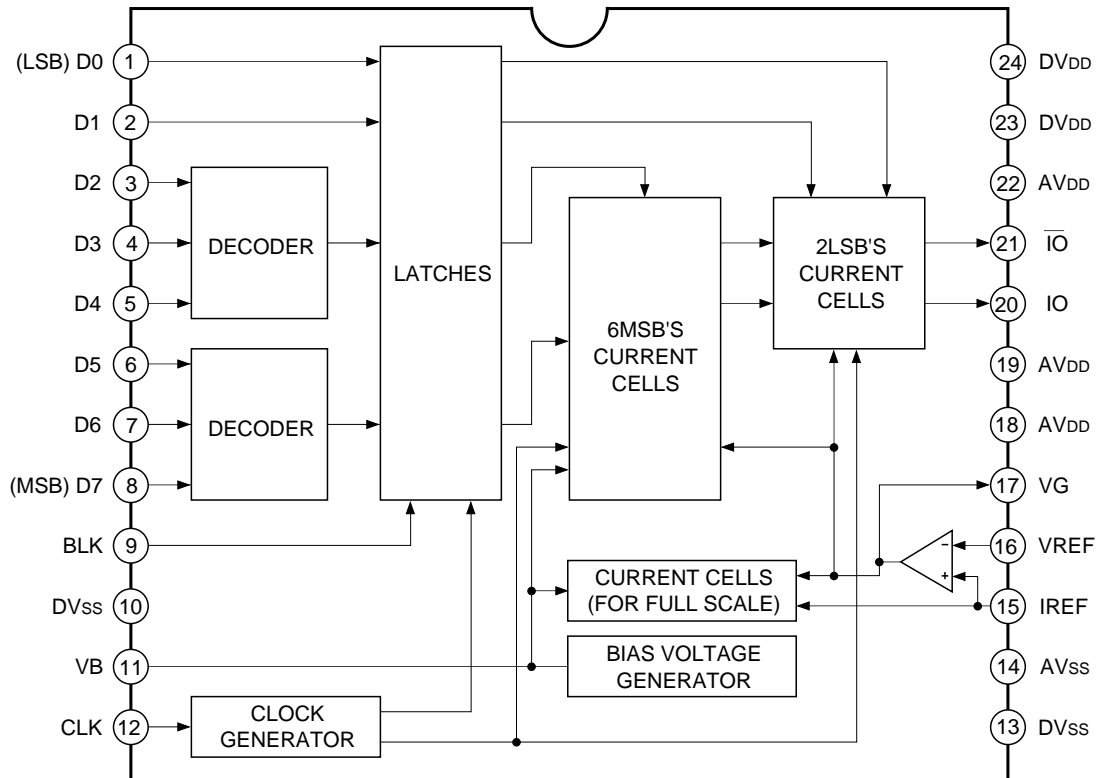

Pin Description and I/O Pins Equivalent Circuit

No.	Symbol	I/O	Equivalent circuit	Description
1 to 8	D0 to D7	I		<p>Digital input. D0 (LSB) to D7 (MSB) D0 and D1 have a pull-down resistor.</p>
9	BLK	I		<p>Blanking input. This is synchronized with the clock signal. No signal at "H" (Output 0 V). Output condition at "L".</p>
11	VB	O		<p>Connect a capacitor of about 0.1 μF.</p>
12	CLK	I		<p>Clock input.</p>
10, 13	DVss	—		Digital ground.
14	AVss	—		Analog ground.

No.	Symbol	I/O	Equivalent circuit	Description
15	IREF	O		Connect a resistor "R <sub>IR</sub> " 16 times against the output resistance value "R <sub>OUT</sub> " connected to Pin 20 (IO).
16	VREF	I		Set full-scale output value.
17	VG	O		Connect a capacitor of about 0.1 μF.
18, 19, 22	AV <sub>DD</sub>	—		Analog power supply.
20	IO	O		Current output. Voltage output can be obtained by connecting a resistance.
21	$\overline{\text{IO}}$			Inverted current output. Normally connected to analog GND.
23, 24	DV <sub>DD</sub>	—		Digital power supply.

**Electrical Characteristics**

( $F_{CLK}=40\text{ MHz}$ ,  $AV_{DD}=DV_{DD}=5\text{ V}$ ,  $R_{OUT}=200\ \Omega$ ,  $V_{REF}=2.0\text{ V}$ ,  $T_a=25\text{ }^\circ\text{C}$ )

Item	Symbol	Measurement conditions	Min.	Typ.	Max.	Unit	
Resolution	n			8		bit	
Conversion speed	$F_{CLK}$	$AV_{DD}=DV_{DD}=4.75\text{ to }5.25\text{ V}$ $T_a=-40\text{ to }85\text{ }^\circ\text{C}$	0.5		40	MSPS	
Integral non-linearity error	$E_L$	Endpoint	-0.5		1.3	LSB	
Differential non-linearity error	$E_D$		-0.25		0.25	LSB	
Output full-scale voltage	$V_{FS}$		1.9	2.0	2.1	V	
Output full-scale current	$I_{FS}$			10	15	mA	
Output offset voltage	$V_{OS}$	When D0 to D7=00000000 input			1	mV	
Glitch energy	GE	$R_{OUT}=75\ \Omega$		30		pV·s	
Supply current	$I_{DD}$	When 14.3 MHz color bar data input	13	14.5	16	mA	
Analog input resistance	$R_{IN}$	$V_{REF}$	1			M $\Omega$	
Input capacitance	$C_i$				9	pF	
Digital input voltage	$V_{IH}$	$AV_{DD}=DV_{DD}=4.75\text{ to }5.25\text{ V}$ $T_a=-20\text{ to }+75\text{ }^\circ\text{C}$	2.4			V	
	$V_{IL}$				0.8		
Digital input current	$I_{IH}$	$AV_{DD}=DV_{DD}=4.75\text{ to }5.25\text{ V}$ $T_a=-20\text{ to }+75\text{ }^\circ\text{C}$	D0, D1	-5		240	$\mu\text{A}$
	$I_{IL}$		D2 to 7, BLK, CLK	-5		5	
Setup time	$t_s$	$R_{OUT}=75\ \Omega$	5			ns	
Hold time	$t_H$	$R_{OUT}=75\ \Omega$	10			ns	
Propagation delay time	$t_{PD}$			10		ns	

**Electrical Characteristics Measurement Circuit**

Analog Input Resistance } Measurement Circuit  
 Digital Input Current }

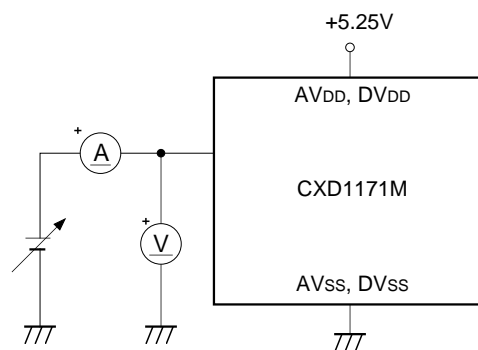

**Maximum Conversion Speed Measurement Circuit**

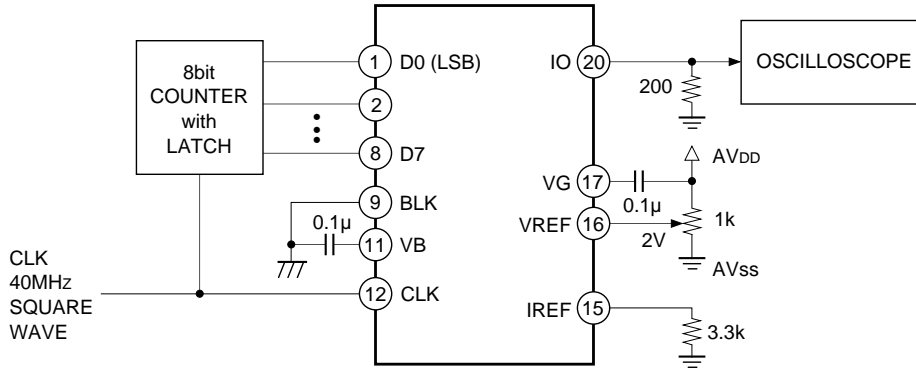

**DC Characteristics Measurement Circuit**

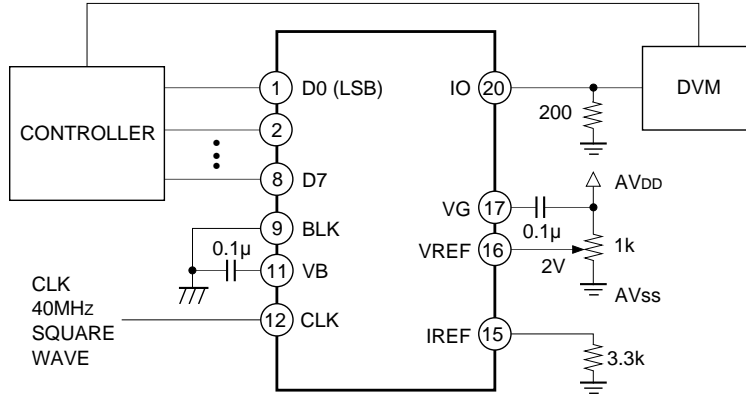

**Propagation Delay Time Measurement Circuit**

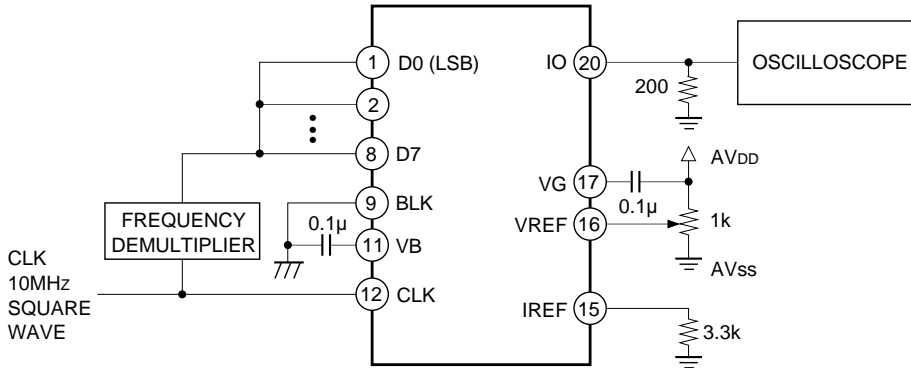

Setup Time  
Hold Time  
Glitch Energy

**measurement Circuit**

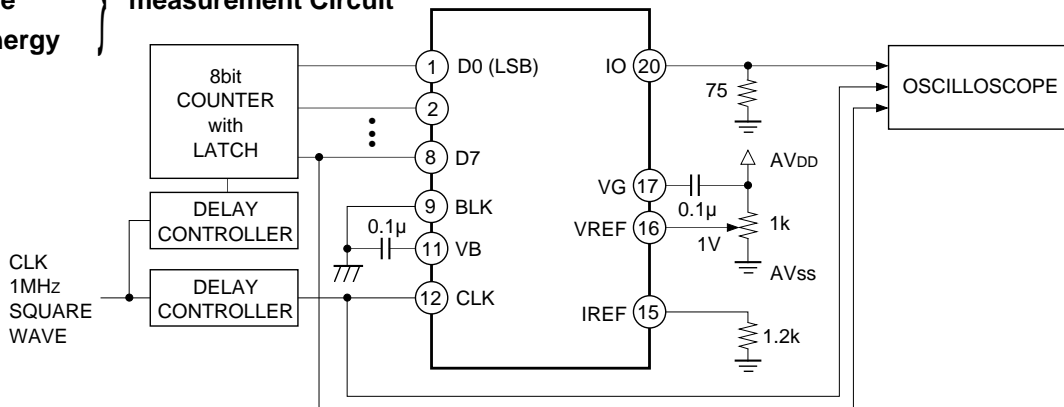



## Notes on Operation

- How to select the output resistance

The CXD1171M is a D/A converter of the current output type. To obtain the output voltage connect the resistance to the current output pin IO. For specifications we have:

Output full scale voltage  $V_{FS} = 1.9$  to  $2.1$  [V]

Output full scale current  $I_{FS} =$  less than  $15$  [mA]

Calculate the output resistance value from the relation of  $V_{FS} = I_{FS} \times R_{OUT}$ . Also, 16 times resistance of the output resistance is connected to reference current pin IREF. In some cases, however, this turns out to be a value that does not actually exist. In such a case a value close to it can be used as a substitute. Here please note that  $V_{FS}$  becomes  $V_{FS} = V_{REF} \times 16R_{OUT}/R_{IR}$ .  $R_{OUT}$  is the resistance connected to IO while  $R_{IR}$  is connected to IREF. Increasing the resistance value can curb power consumption. On the other hand glitch energy and data settling time will inversely increase. Set the most suitable value according to the desired application.

- Phase relation between data and clock

To obtain the expected performance as a D/A converter, it is necessary to set properly the phase relation between data and clock applied from the exterior. Be sure to satisfy the provisions of the setup time ( $t_s$ ) and hold time ( $t_h$ ) as stipulated in the Electrical Characteristics.

- Power supply and ground

To reduce noise effects separate analog and digital systems in the device periphery. For the power supply pins, both digital and analog, bypass respective grounds by using a ceramic capacitor of about  $0.1 \mu\text{F}$ , as close as possible to the pin.

- Latch up

$AV_{DD}$  and  $DV_{DD}$  have to be common at the PCB power supply source. This is to prevent latch up due to voltage difference between  $AV_{DD}$  and  $DV_{DD}$  pins when power supply is turned ON.

- $\overline{IO}$  pin

The  $\overline{IO}$  pin is the inverted current output pin described in the Pin Description. The sum of the currents output from the  $\overline{IO}$  pin and the IO pin becomes the constant value for any input data.

However, the performances such as the linearity error of the  $\overline{IO}$  pin output current is not guaranteed.

**Latch Up Prevention**

The CXD1171M is a CMOS IC which requires latch up precautions. Latch up is mainly generated by the lag in the voltage rising time of AV<sub>DD</sub> (Pins 18, 19 and 22) and DV<sub>DD</sub> (Pins 23 and 24), when power supply is ON.

**1. Correct usage**

**a. When analog and digital supplies are from different sources**

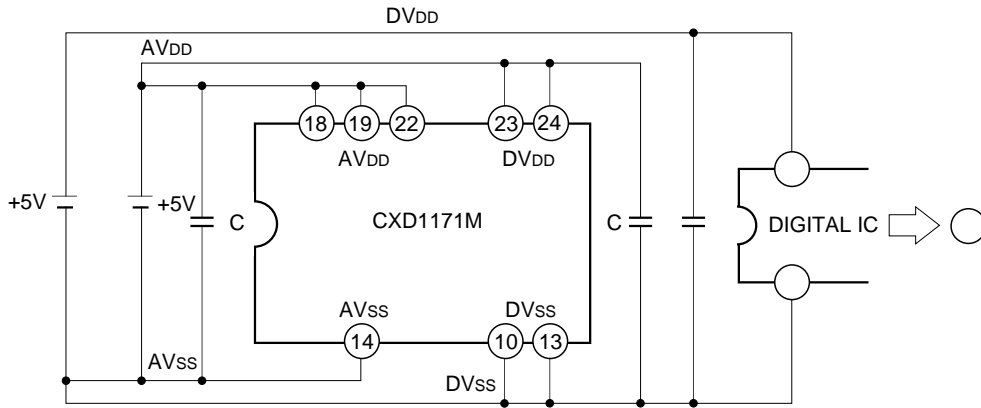

**b. When analog and digital supplies are from a common source**

(i)

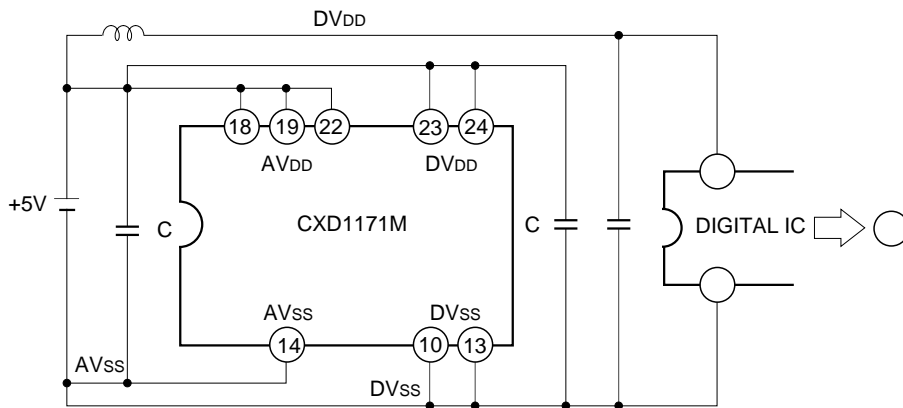

(ii)

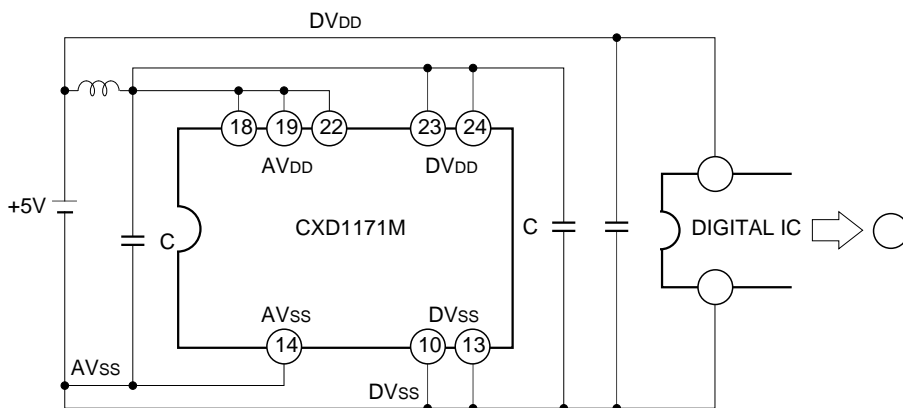

2. Example when latch up easily occurs

a. When analog and digital supplies are from different sources

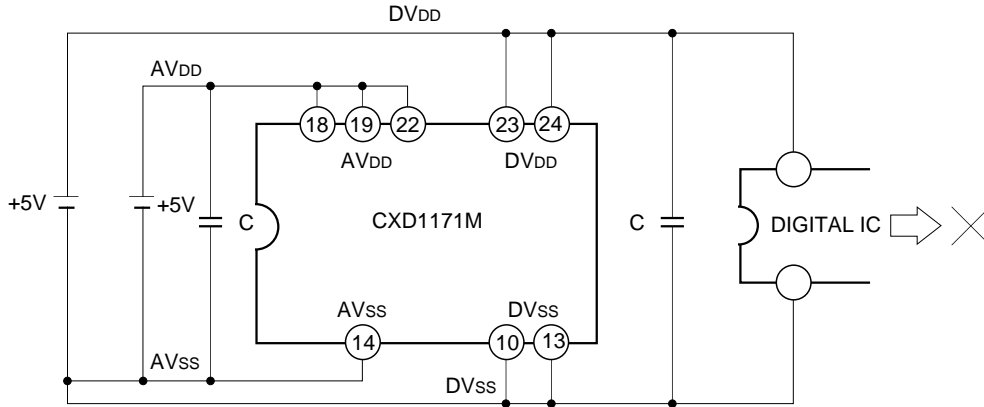

b. When analog and digital supplies are from common source

(i)

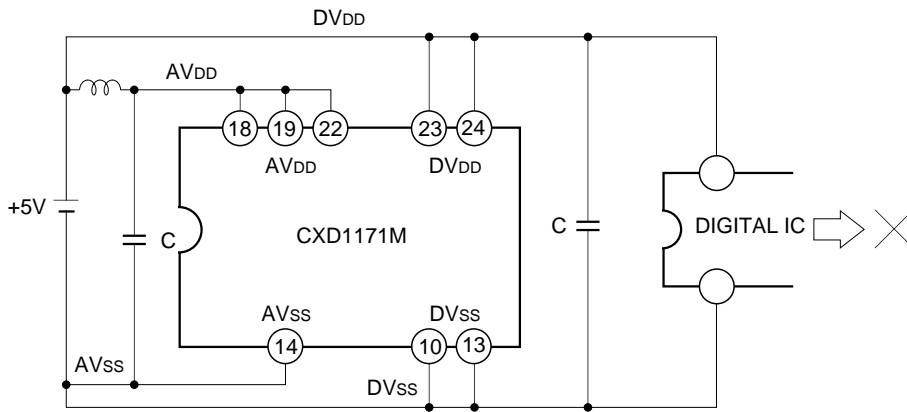

(ii)

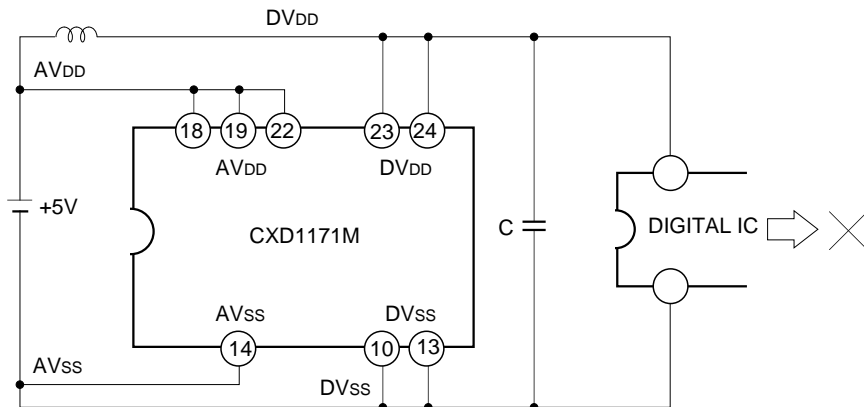

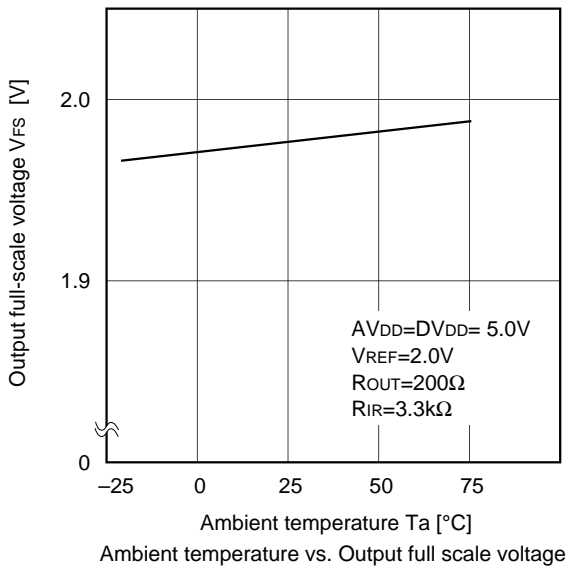
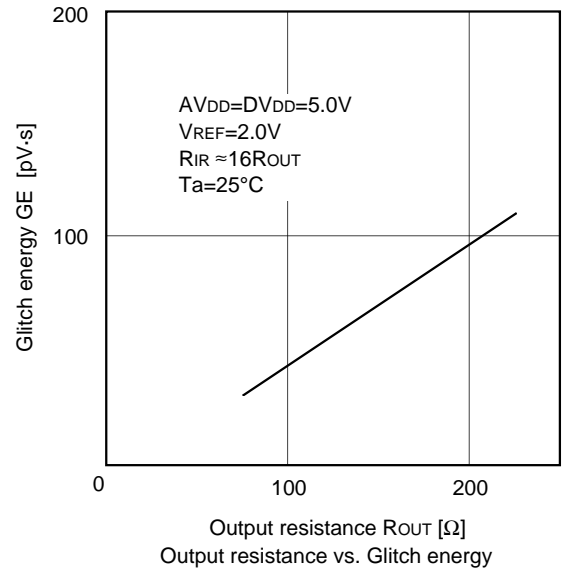
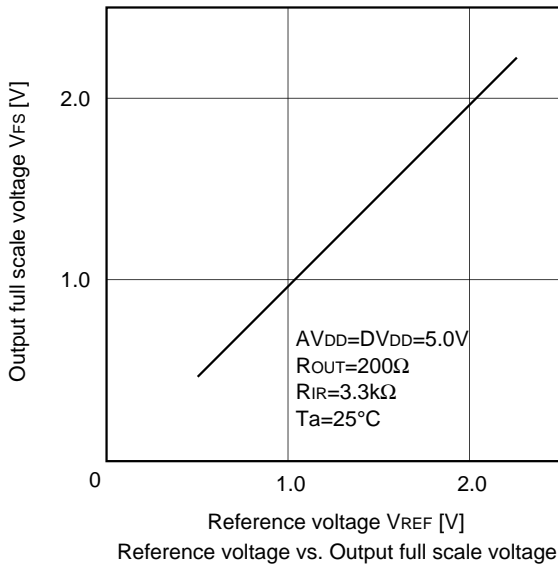

Package Outline Unit : mm

24PIN SOP (PLASTIC)

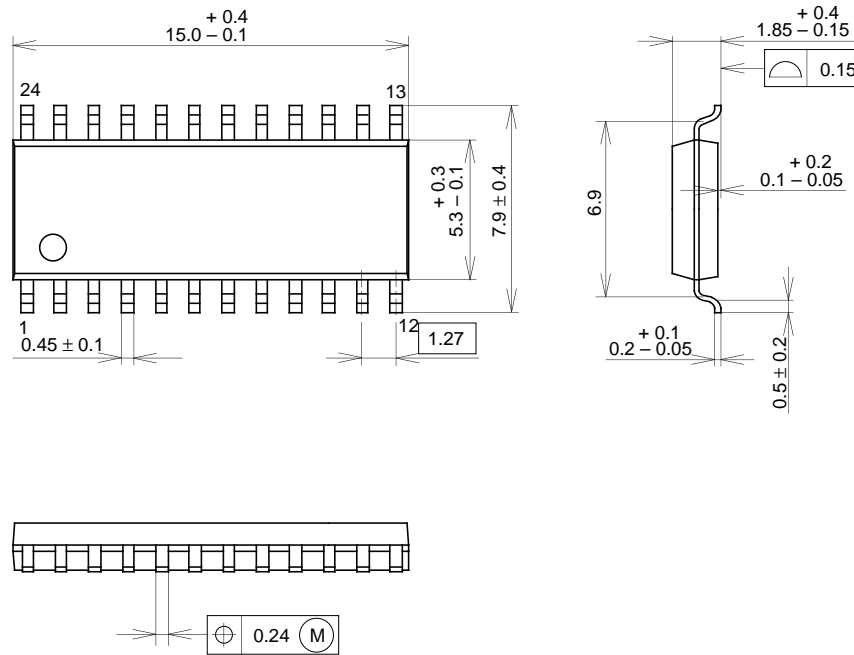

PACKAGE STRUCTURE

SONY CODE	SOP-24P-L01
EIAJ CODE	SOP024-P-0300
JEDEC CODE	_____

MOLDING COMPOUND	EPOXY RESIN
LEAD TREATMENT	SOLDER PLATING
LEAD MATERIAL	42/COPPER ALLOY
PACKAGE MASS	0.3g

Package Outline Unit : mm

24PIN SOP (PLASTIC)

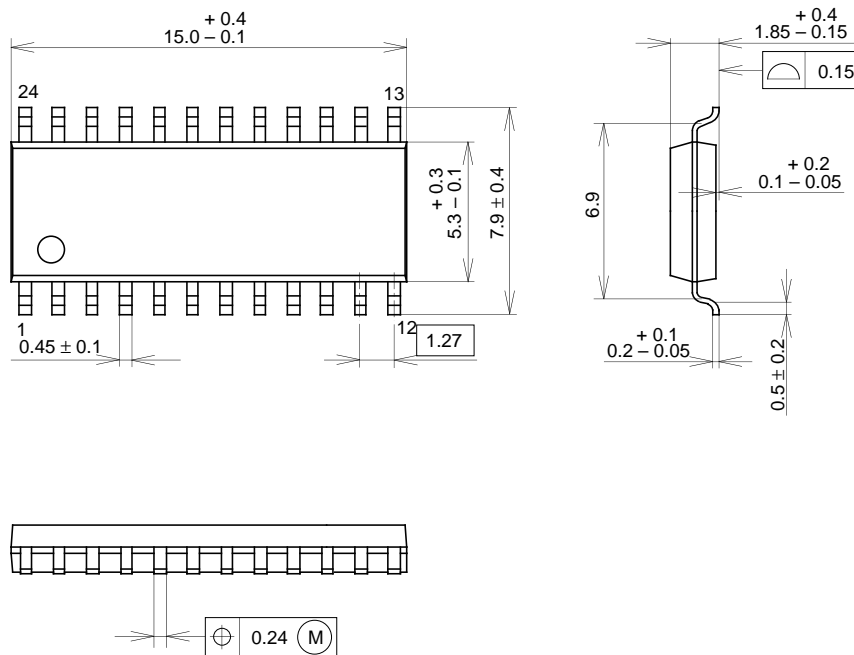

PACKAGE STRUCTURE

SONY CODE	SOP-24P-L01
EIAJ CODE	SOP024-P-0300
JEDEC CODE	_____

MOLDING COMPOUND	EPOXY RESIN
LEAD TREATMENT	SOLDER PLATING
LEAD MATERIAL	42/COPPER ALLOY
PACKAGE MASS	0.3g

LEAD SPECIFICATIONS

ITEM	SPEC.
LEAD MATERIAL	COPPER ALLOY
LEAD TREATMENT	Sn-Bi 2.5%
LEAD TREATMENT THICKNESS	5-18 $\mu$ m



LittleDiode supplies new, hard to find or obsolete electronic components and semiconductors all over the world.

With over two million different components listed you are sure to find the part you need.

Feel free to visit us today at our online store:

[LittleDiode.com](http://LittleDiode.com)

Looking forward to providing you with the best possible service.