

CXD1172AM/AP

6-bit 20MSPS Video A/D Converter (CMOS)

Description

CXD1172AM/AP is a 6-bit CMOS A/D converter for video use. The adoption of a 2-step parallel system achieves low consumption at a maximum conversion speed of 20MSPS minimum, 35MSPS typical.

Features

- Resolution: 6-bit $\pm 1/2$ LSB
- Max. sampling frequency: 20MSPS
- Low power consumption: 40mW (at 20MSPS typ.)
(Reference current excluded)
- Built-in sampling and hold circuit.
- 3-state TTL compatible output.
- Power supply: 5V single
- Low input capacitance: 4pF
- Reference impedance: 250 Ω (typ.)

Applications

TV, VCR digital systems and a wide range of fields where high speed A/D conversion is required.

Structure

Silicon gate CMOS monolithic IC

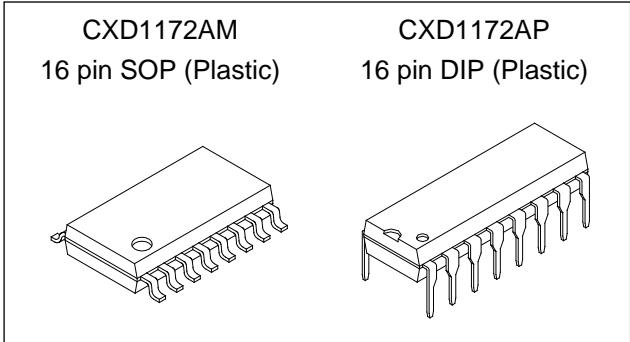

Absolute Maximum Ratings (Ta = 25°C)

• Supply voltage	V _{DD}	7	V
• Reference voltage	V _{RT} , V _{RB}	V _{DD} + 0.5 to V _{SS} - 0.5	V
• Input voltage (Analog)	V _{IN}	V _{DD} + 0.5 to V _{SS} - 0.5	V
• Input voltage (Digital)	V _{CLK}	V _{DD} + 0.5 to V _{SS} - 0.5	V
• Output voltage (Digital)	V _{OH} , V _{OL}	V _{DD} + 0.5 to V _{SS} - 0.5	V
• Storage temperature	T _{stg}	-55 to +150	°C

Recommended Operating Conditions

• Supply voltage	AV _{DD} , AV _{SS}	4.75 to 5.25	V
	DV _{DD} , DV _{SS}	4.75 to 5.25	V
• Reference input voltage	V _{RB}	0 to 4.1	V
	V _{RT}	0.9 to 5.0	V
	V _{RT} - V _{RB}	0.9 to AV _{DD}	V
• Analog input voltage	V _{IN}	V _{RB} to V _{RT}	V
• Clock pulse width	T _{PW1} , T _{PW0}	23ns (min.) to 1.1 μ s (max.)	
• Operating temperature	T _{opr}	-20 to +75	°C

Sony reserves the right to change products and specifications without prior notice. This information does not convey any license by any implication or otherwise under any patents or other right. Application circuits shown, if any, are typical examples illustrating the operation of the devices. Sony cannot assume responsibility for any problems arising out of the use of these circuits.

Block Diagram and Pin Configuration

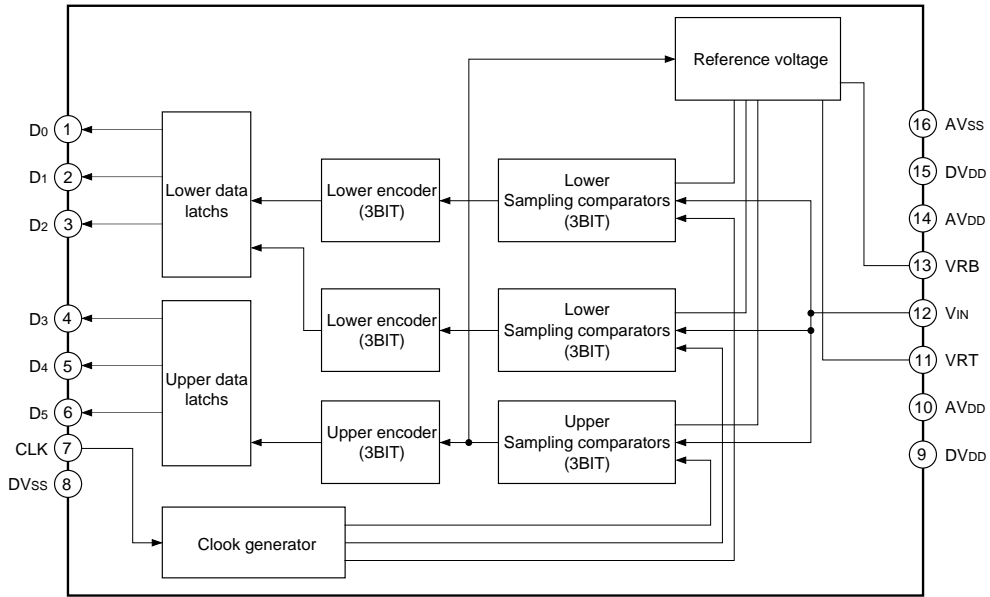

Pin Description and Equivalent Circuits

No.	Symbol	Equivalent Circuit	Description
1 to 6	D ₀ to D ₅		D ₀ (LSB) to D ₅ (MSB) output
7	CLK		Clock input
8	DVSS		Digital GND
9, 15	DVDD		Digital +5V
10, 14	AVDD		Analog +5V
11	VRT		Reference voltage (Top)
13	VRB		Reference voltage (Bottom)
12	V _{IN}		Analog input
16	AVSS		Analog GND

Digital Output

Compatibility between Analog input voltage and the digital output code is indicated in the chart below.

Input signal voltage	Step	Digital output code					
		MSB					LSB
V _{RT}	0	1	1	1	1	1	1
⋮	⋮						⋮
⋮	31	1	0	0	0	0	0
⋮	32	0	1	1	1	1	1
⋮	⋮						⋮
V _{RB}	63	0	0	0	0	0	0

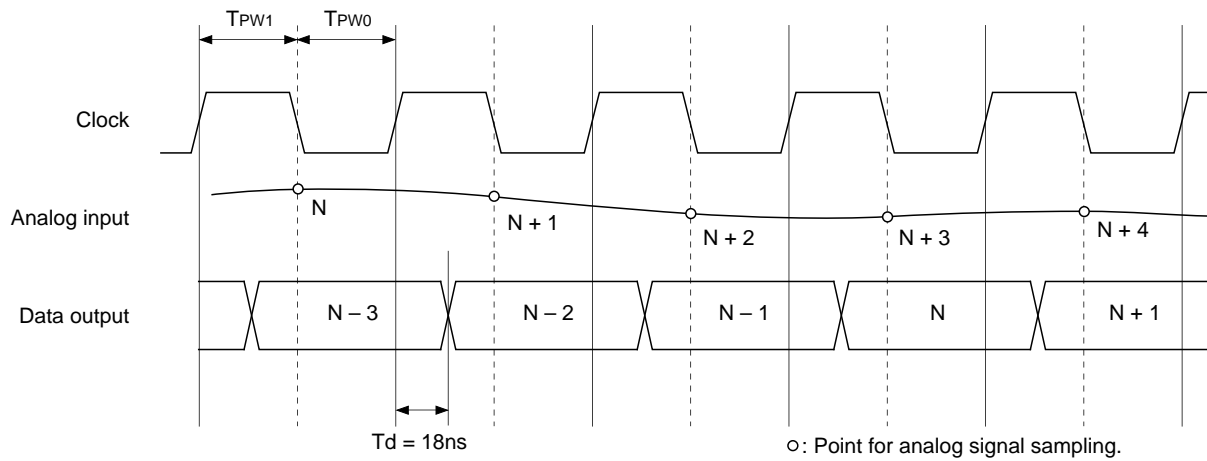

Timing Chart 1

Electrical Characteristics

(V_{DD} = 5V, V_{RB} = 1.0V, V_{RT} = 2.0V, T_a = 25°C)

Item	Symbol	Conditions	Min.	Typ.	Max.	Unit	
Conversion speed	F _c	V _{DD} = 4.75 to 5.25V T _a = -20 to +75°C V _{IN} = 1.0 to 2.0V f _{IN} = 1kHz ramp	0.5		20	MSPS	
Supply current	I _{DD}	F _c = 20MSPS NTSC ramp wave input		7	12	mA	
Reference pin current	I _{REF}		3	4	5.7		
Analog input band width (-1dB)	BW	Envelope		18		MHz	
Analog input capacitance	C _{IN}	V _{IN} = 1.5V + 0.07V _{rms}		4		pF	
Reference resistance (V _{RT} to V _{RB})	R _{REF}		175	250	325	Ω	
Offset voltage*1	E _{OT}	Potential difference to V _{RT}	0	-20	-40	mV	
	E _{OB}	Potential difference to V _{RB}	15	35	55		
Digital input voltage	V _{IH}	V _{DD} = 4.75 to 5.25V T _a = -20 to +75°C	4.0			V	
	V _{IL}						1.0
Digital input current	I _{IH}	V _{DD} = max.				μA	
	I _{IL}						V _{IL} = 0V
Digital output current	I _{OH}	V _{DD} = min.				mA	
	I _{OL}						V _{OL} = 0.4V
Output data delay	T _{DL}	With TTL 1 gate and 10pF load T _a = -20 to +75°C V _{DD} = 4.75 to 5.25V		18	30	ns	
Integral non-linearity error	E _L	End point			±0.3	±0.5	LSB
Differential non-linearity error	E _D				±0.3	±0.5	
Differential gain error	DG	NTSC 40 IRE mod ramp F _c = 14.3MSPS			1.0		%
Differential phase error	DP				1.0		deg
Aperture jitter	T _{aj}			40		ps	
Sampling delay	T _{sd}			4		ns	

*1 The offset voltage EOB is a potential difference between V_{RB} and a point of position where the voltage drops equivalent to 1/2 LSB of the voltage when the output data changes from "00000000" to "00000001". EOT is a potential difference between V_{RT} and a potential of point where the voltage rises equivalent to 1/2 LSB of the voltage when the output data changes from "11111111" to "11111110".

Electrical Characteristics Test Circuit

Integral non-linearity error }
 Differential non-linearity } Test Circuit
 Offset voltage }

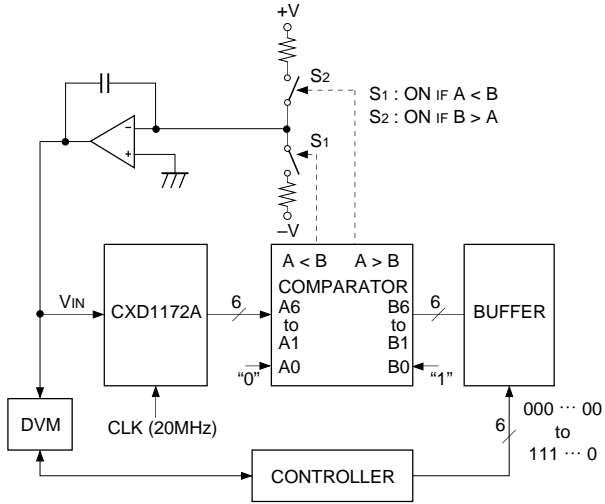

Maximum operational speed }
 Differential gain error } Test Circuit
 Differential phase error }

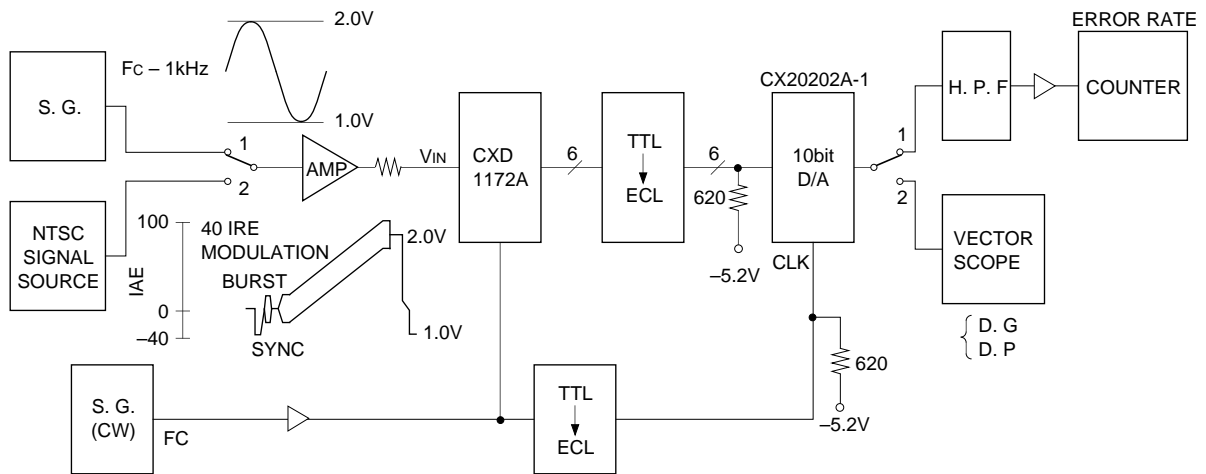

Digital output current test circuit

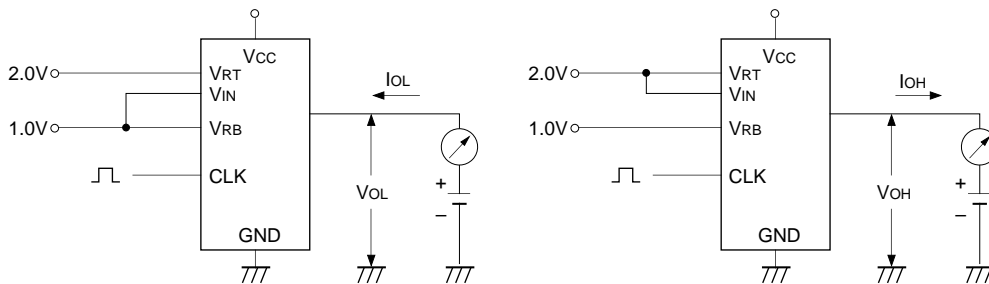

Timing Chart 2

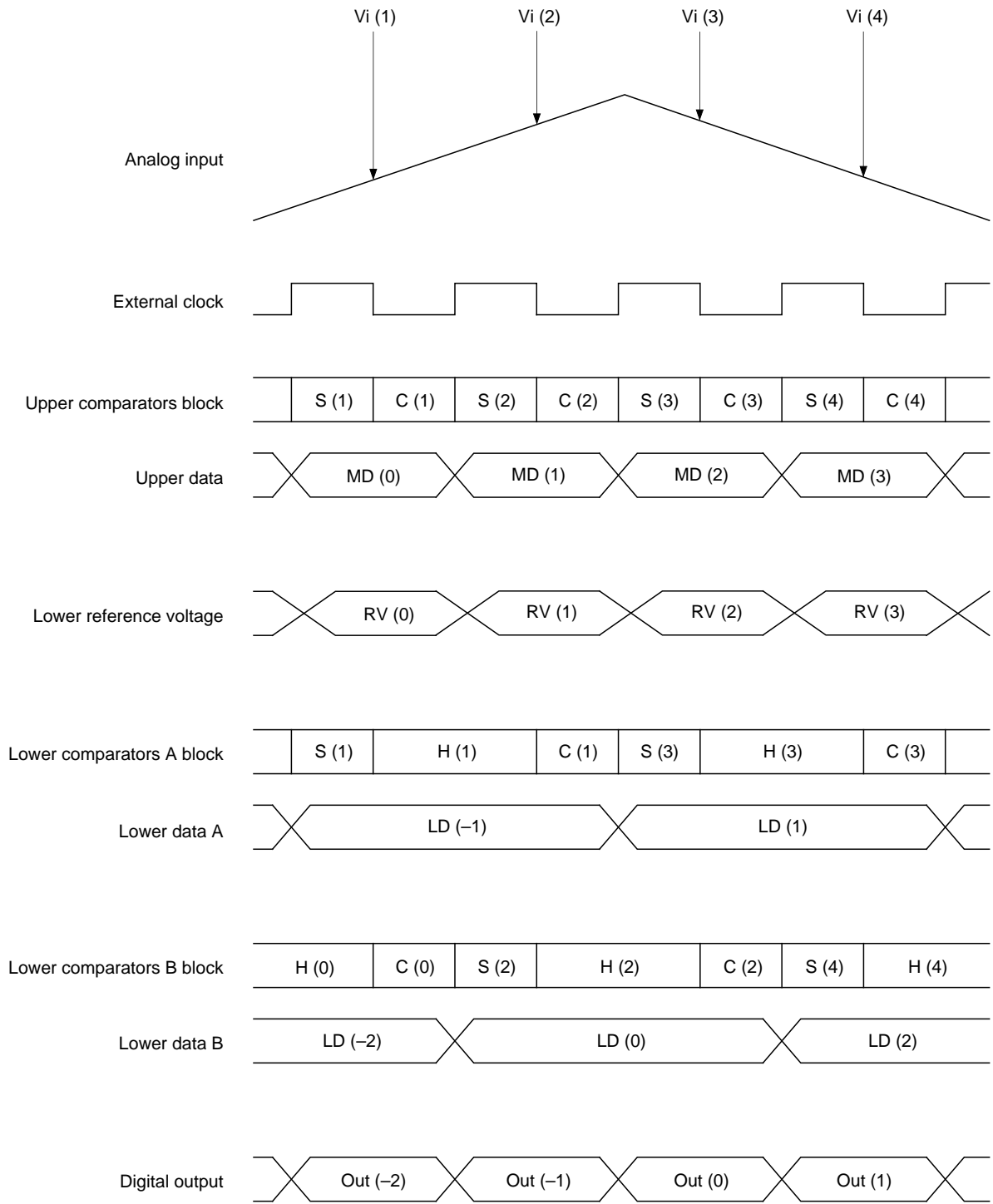

Operation (See Block Diagram and Timing Chart)

1. CXD1172AM/AP is a 2-step parallel system A/D converter featuring a 3-bit upper comparators group and 2 lower comparators groups of 3-bit each. The reference voltage that is equal to the voltage between VRT-VRB/8 is constantly applied to the upper 3-bit comparator block. Voltage that corresponded to the upper data is fed through the reference supply to the lower data.
2. This IC uses an offset cancel type comparator and operates synchronously with an external clock. It features the following operating modes which are respectively indicated on the timing chart with S, H, C symbols. That is input sampling (auto zero) mode, input hold mode and comparison mode.
3. The operation of respective parts is as indicated in the chart. For instance input voltage V_i (1) is sampled with the falling edge of the first clock by means of the upper comparator block and the lower comparator A block. The upper comparators block finalizes comparison data MD (1) with the rising edge of the first clock. Simultaneously the reference supply generates the lower reference voltage RV (1) that corresponded to the upper results. The lower comparator block finalizes comparison data LD (1) with the rising edge of the second clock. MD (1) and LD (1) are combined and output as Out (1) with the rising edge of the 3rd clock. Accordingly there is a 2.5 clock delay from the analog input sampling point to the digital data output.

Operation Notes1. V_{DD} , V_{SS}

To reduce noise effects, separate the analog and digital systems close to the device. For both the digital and analog V_{DD} pins, use a ceramic capacitor of about 0.1 μ F set as close as possible to the pin to bypass to the respective GND's.

2. Analog input

Compared with the flash type A/D converter, the input capacitance of the analog input is rather small. However it is necessary to conduct the drive with an amplifier featuring sufficient band and drive capability. When driving with an amplifier of low output impedance, parasite oscillation may occur. That may be prevented by inserting a resistance of about 100 Ω in series between the amplifier output and A/D input.

3. Clock input

The clock line wiring should be as short as possible also, to avoid any interference with other signals, separate it from other circuits.

4. Reference input

Voltage between VRT to VRB is compatible with the dynamic range of the analog input. Bypassing VRT and VRB pins to GND, by means of a capacitor about 0.1 μ F, stable characteristics are obtained.

5. Timing

Analog input is sampled with the falling edge of CLK and output as digital data with a delay of 2.5 clocks and with the following rising edge. The delay from the clock rising edge to the data output is about 18ns.

6. About latch up

It is necessary that AV_{DD} and DV_{DD} pins be the common source of power supply.

This is to avoid latch up due to the voltage difference between AV_{DD} and DV_{DD} pins when power is ON.

See "For latch up prevention" of CXD1172P/CXA1106P PCB description. (Page 6, 7)

Latch Up Prevention

The CXD1172A is a CMOS IC which requires latch up precautions. Latch up is mainly generated by the lag in the voltage rising time of AV_{DD} (Pins 10 and 14) and DV_{DD} (Pins 9 and 15), when power supply is ON.

1. Correct usage

a. When analog and digital supplies are from different sources

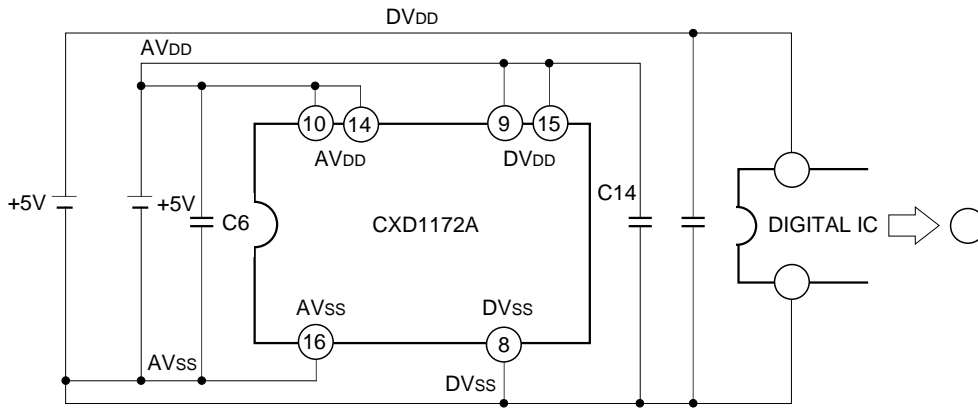

b. When analog and digital supplies are from a common source

(i)

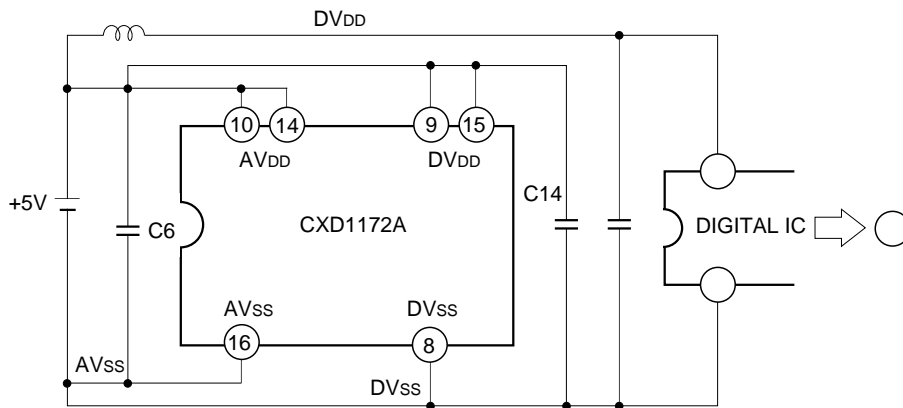

(ii)

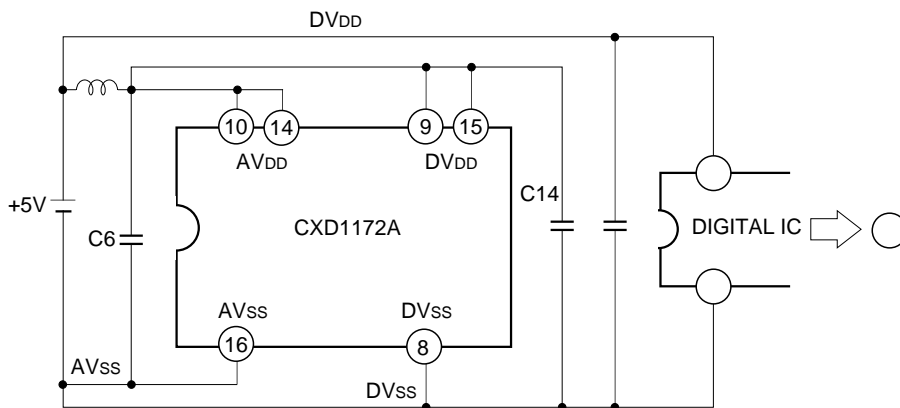

2. Example when latch up easily occurs

a. When analog and digital supplies are from different sources

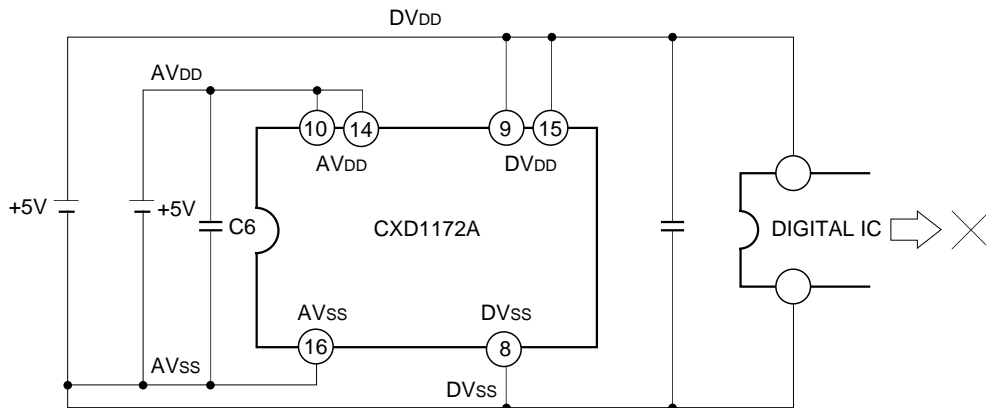

b. When analog and digital supplies are from common source

(i)

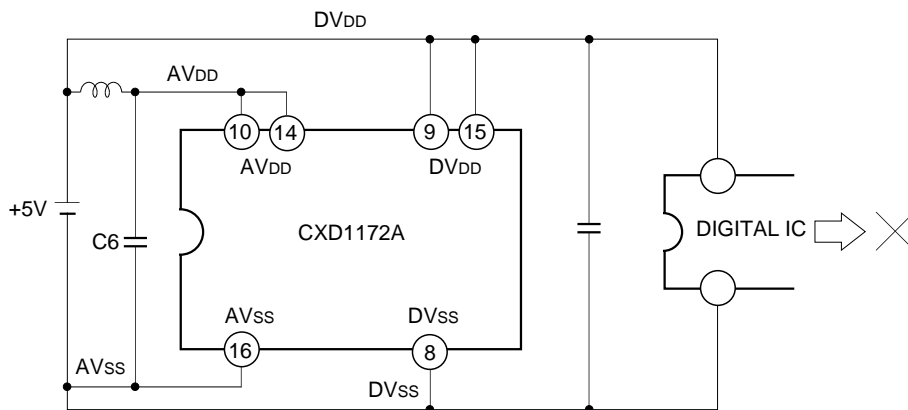

(ii)

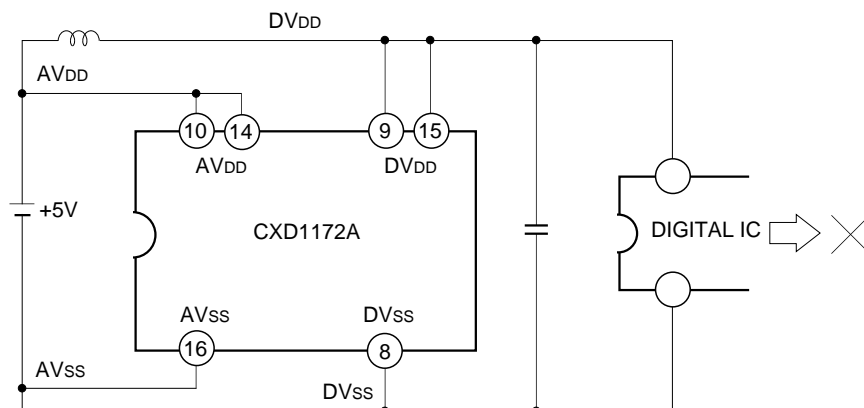

6-bit, 20MSPS ADC and DAC Evaluation Board

Silk Side

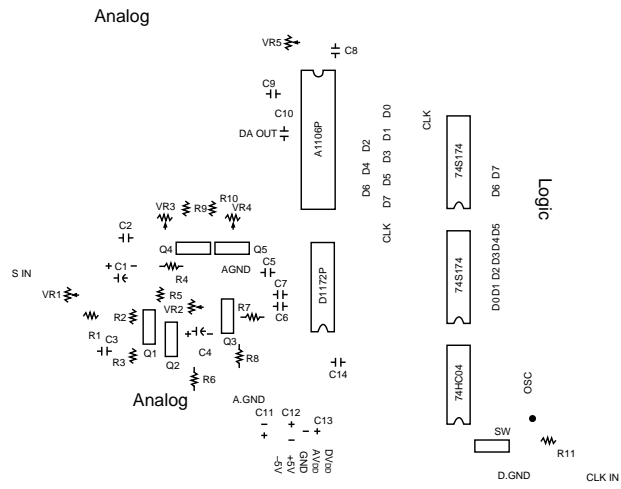

Component Side

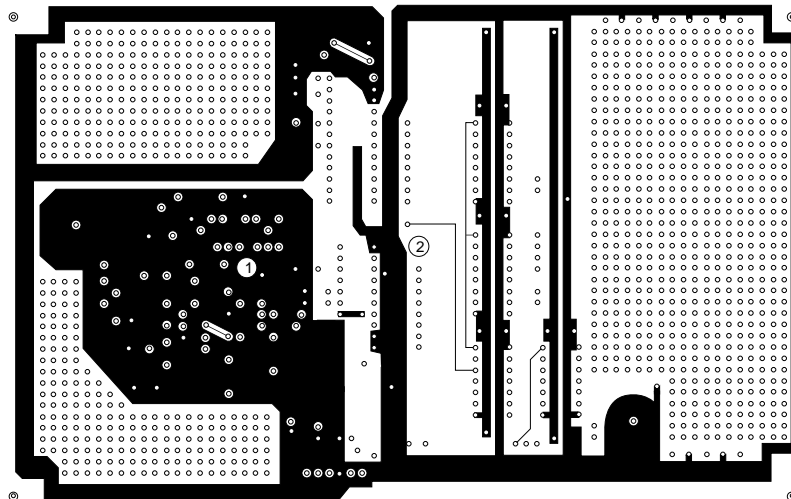

Soldering Side

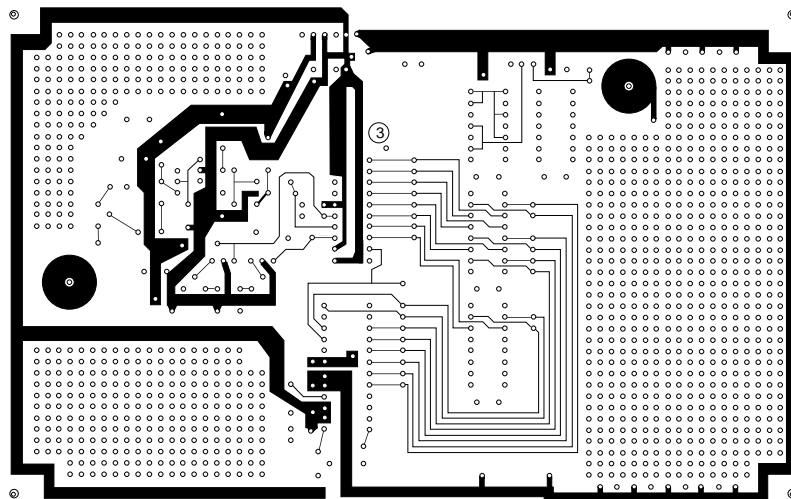

Package Outline Unit: mm

CXD1172AM

16PIN SOP (PLASTIC) 300mil

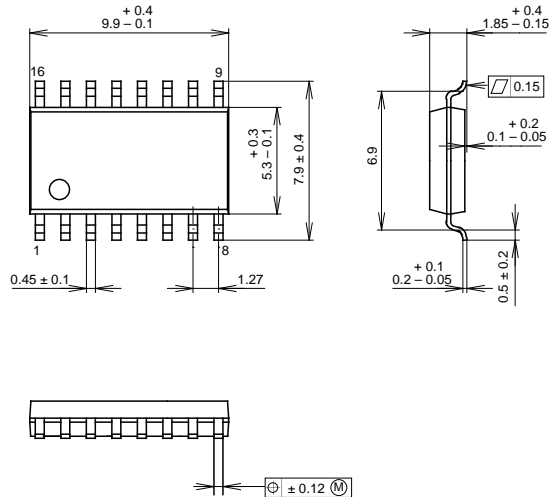

SONY CODE	SOP-16P-L01
EIAJ CODE	+SOP016-P-0300-A
JEDEC CODE	

PACKAGE STRUCTURE

PACKAGE MATERIAL	EPOXY RESIN
LEAD TREATMENT	SOLDER PLATING
LEAD MATERIAL	COPPER ALLOY
PACKAGE WEIGHT	0.2g

CXD1172AP

16PIN DIP (PLASTIC)

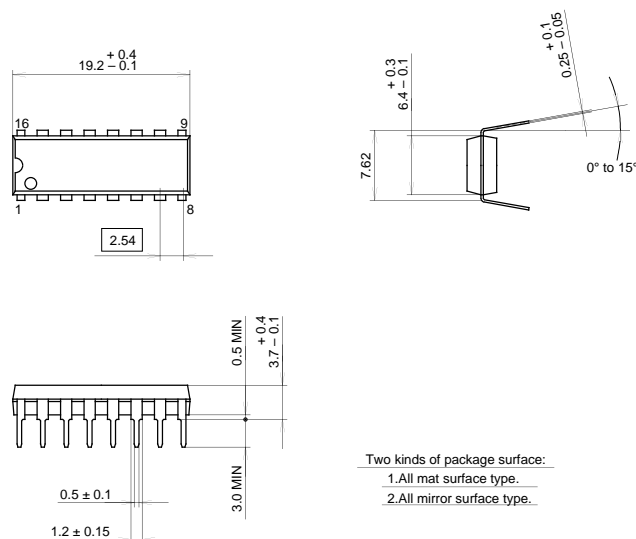

- Two kinds of package surface:
1. All mat surface type.
 2. All mirror surface type.

SONY CODE	DIP-16P-01
EIAJ CODE	DIP016-P-0300
JEDEC CODE	Similar to MO-001-AE

PACKAGE STRUCTURE

PACKAGE MATERIAL	EPOXY RESIN
LEAD TREATMENT	SOLDER PLATING
LEAD MATERIAL	COPPER ALLOY
PACKAGE MASS	1.0 g



LittleDiode supplies new, hard to find or obsolete electronic components and semiconductors all over the world.

With over two million different components listed you are sure to find the part you need.

Feel free to visit us today at our online store:

LittleDiode.com

Looking forward to providing you with the best possible service.