

CXD1175AM/AP

8-bit 20MSPS Video A/D Converter (CMOS)

Description

The CXD1175A is an 8-bit CMOS A/D converter for video use. The adoption of a 2-step parallel system achieves low consumption at a maximum conversion speed of 20MSPS minimum, 35MSPS typical.

Features

- Resolution: 8 bit \pm 1/2LSB (DL)
- Maximum sampling frequency: 20MSPS
- Low power consumption: 60mW (at 20MSPS typ.) (reference current excluded)
- Built-in sampling and hold circuit
- Built-in reference voltage self-bias circuit
- 3-state TTL compatible output
- Power supply: 5V single
- Low input capacitance: 11pF
- Reference impedance: 300 Ω (typ.)

Applications

TV, VCR digital systems and a wide range of fields where high speed A/D conversion is required.

Structure

Silicon gate CMOS monolithic IC

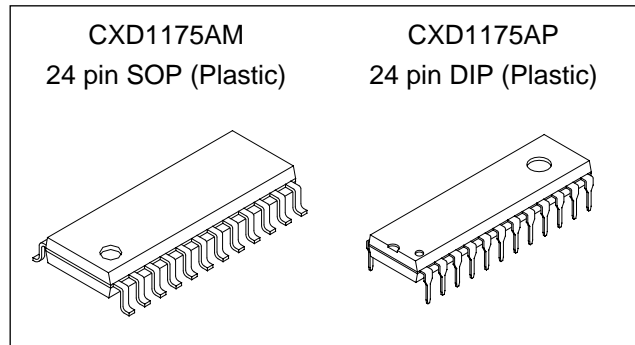

Absolute Maximum Ratings (Ta = 25°C)

- Supply voltage V_{DD} 7 V
- Reference voltage V_{RT}, V_{RB} $V_{DD} + 0.5$ to $V_{SS} - 0.5$
- Input voltage V_{IN} $V_{DD} + 0.5$ to $V_{SS} - 0.5$ (Analog)
- Input voltage V_I $V_{DD} + 0.5$ to $V_{SS} - 0.5$ (Digital)
- Output voltage V_O $V_{DD} + 0.5$ to $V_{SS} - 0.5$ (Digital)
- Storage temperature T_{stg} -55 to +150 °C

Recommended Operating Conditions

- Supply voltage AV_{DD}, AV_{SS} 4.75 to 5.25 V
 DV_{DD}, DV_{SS} | $DV_{SS} - AV_{SS}$ | 0 to 100 mV
- Reference input voltage V_{RB} 0 and above V
 V_{RT} 2.8 and below V
- Analog input V_{IN} 1.8Vp-p above
- Clock pulse width $TPW1, TPW0$ 23ns (min) to 1.1 μ s (max)
- Operating ambient temperature T_{opr} -40 to +85 °C

Sony reserves the right to change products and specifications without prior notice. This information does not convey any license by any implication or otherwise under any patents or other right. Application circuits shown, if any, are typical examples illustrating the operation of the devices. Sony cannot assume responsibility for any problems arising out of the use of these circuits.

Block Diagram and Pin Configuration

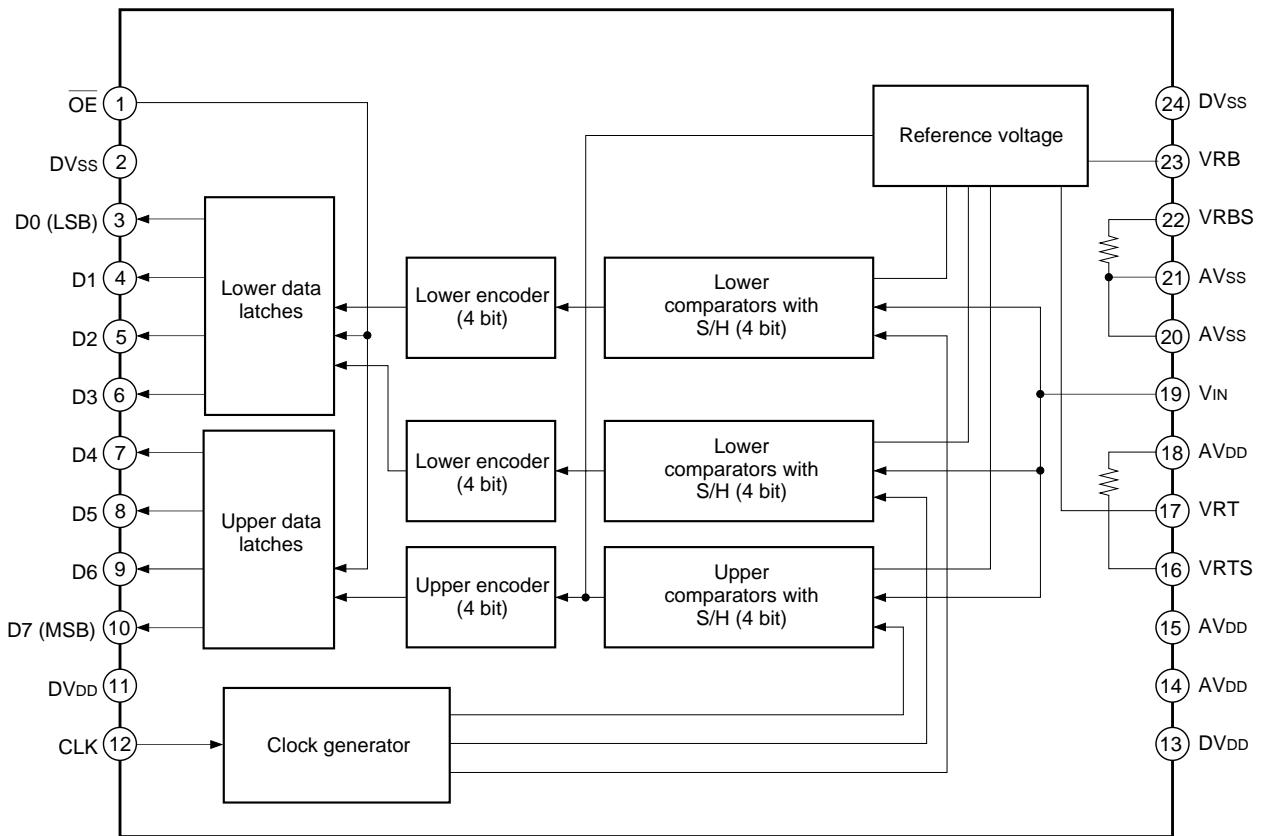

Pin Description and Equivalent Circuits

| No. | Symbol | Equivalent circuit | Description |
|------------|-----------------|--------------------|---|
| 1 | \overline{OE} | | When \overline{OE} = Low, Data is output. When \overline{OE} = High, D0 to D7 pins turn to High impedance. |
| 2, 24 | DVSS | | Digital ground |
| 3 to 10 | D0 to D7 | | D0 (LSB) to D7 (MSB) output |
| 11, 13 | DVDD | | Digital +5V |
| 12 | CLK | | Clock input |
| 16 | VRTS | | Shorted with VRT generates, +2.6V. |
| 17 | VRT | | Reference voltage (Top) |
| 23 | VRB | | Reference voltage (Bottom) |
| 14, 15, 18 | AVDD | | Analog +5V |
| 19 | V_{IN} | | Analog input |
| 20, 21 | AVSS | | Analog GND |
| 22 | VRBS | | Shorted with VRB generates +0.6V. |

Digital output

Compatibility between analog input voltage and the digital output code is indicated in the chart below.

| Input signal voltage | Step | Digital output code | |
|----------------------|------|---------------------|-----------------|
| | | MSB | LSB |
| V _{RT} | 0 | 1 | 1 1 1 1 1 1 1 1 |
| ⋮ | ⋮ | | ⋮ |
| ⋮ | 127 | 1 | 0 0 0 0 0 0 0 0 |
| ⋮ | 128 | 0 | 1 1 1 1 1 1 1 1 |
| ⋮ | ⋮ | | ⋮ |
| V _{RB} | 255 | 0 | 0 0 0 0 0 0 0 0 |

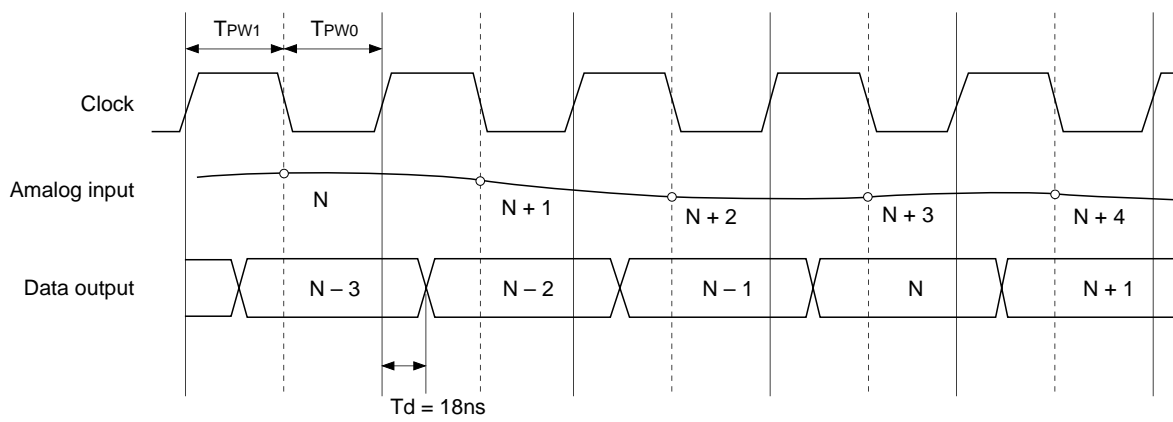

○ : Point for analog signal sampling.

Timing Chart 1

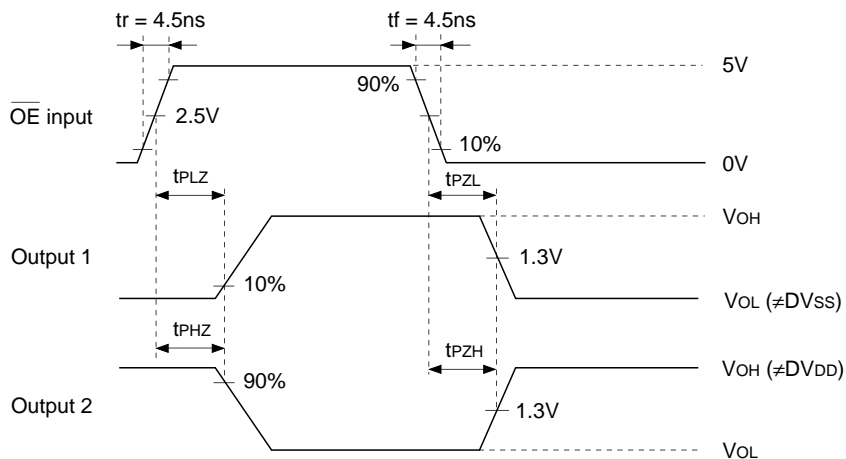

Timing Chart 2

Electrical Characteristics

Analog characteristics

(Fc = 20MSPS, V_{DD} = 5V, V_{RB} = 0.5V, V_{RT} = 2.5V, Ta = 25°C)

| Item | Symbol | Conditions | Min. | Typ. | Max. | Unit |
|----------------------------------|-----------------|--|------|------|------|------|
| Conversion speed | F _c | V _{DD} = 4.75 to 5.25V Ta = -40 to +85°C V _{IN} = 0.5 to 2.5V f _{IN} = 1kHz ramp | 0.5 | | 20 | MSPS |
| Analog input band width (-1dB) | BW | Envelope | | 18 | | MHz |
| Offset voltage*1 | E _{OT} | Potential difference to V _{RT} | -10 | -35 | -60 | mV |
| | E _{OB} | Potential difference to V _{RB} | 0 | +15 | +45 | |
| Integral non-linearity error | E _L | End point | | +0.5 | +1.3 | LSB |
| Differential non-linearity error | E _D | | | ±0.3 | ±0.5 | |
| Differential gain error | DG | NTSC 40 IRE mod ramp Fc = 14.3MSPS | | 1.0 | | % |
| Differential phase error | DP | | | 0.5 | | deg |
| Aperture jitter | t _{aj} | | | 30 | | ps |
| Sampling delay | t _{sd} | | | 4 | | ns |

*1 The offset voltage EOB is a potential difference between V_{RB} and a point of position where the voltage drops equivalent to 1/2 LSB of the voltage when the output data changes from "00000000" to "00000001".
EOT is a potential difference between V_{RT} and a potential of point where the voltage rises equivalent to 1/2LSB of the voltage when the output data changes from "11111111" to "11111110".

DC characteristics

($F_c = 20\text{MSPS}$, $V_{DD} = 5\text{V}$, $V_{RB} = 0.5\text{V}$, $V_{RT} = 2.5\text{V}$, $T_a = 25^\circ\text{C}$)

| Item | Symbol | Conditions | | Min. | Typ. | Max. | Unit |
|--|-----------------|---|---------------------------------|------|------|------|---------------|
| Supply current | I_{DD} | $F_c = 20\text{MSPS}$ NTSC ramp wave input | | | 12 | 17 | mA |
| Reference pin current | I_{REF} | | | 4.5 | 6.6 | 8.7 | mA |
| Analog input capacitance | C_{IN} | $V_{IN} = 1.5\text{V} + 0.07\text{V}_{rms}$ | | | 11 | | pF |
| Reference resistance (V_{RT} to V_{RB}) | R_{REF} | | | 230 | 300 | 450 | Ω |
| Self-bias I | VRB_1 | Shorts VRB and $VRBS$ Shorts VRT and $VRTS$ | | 0.60 | 0.64 | 0.68 | V |
| | $VRT_1 - VRB_1$ | | | 1.96 | 2.09 | 2.21 | |
| Self-bias II | VRT_2 | $VRB = \text{AGND}$ Shorts VRT and $VRTS$ | | 2.25 | 2.39 | 2.53 | V |
| Digital input voltage | V_{IH} | $V_{DD} = 4.75$ to 5.25V $T_a = -40$ to $+85^\circ\text{C}$ | | 3.5 | | | V |
| | V_{IL} | | | | | 1.0 | |
| Digital input current | I_{IH} | $V_{DD} = \text{max}$ | $V_{IH} = V_{DD}$ | | | 5 | μA |
| | I_{IL} | | $V_{IL} = 0\text{V}$ | | | 5 | |
| Digital output current | I_{OH} | $\overline{OE} = V_{SS}$ $V_{DD} = \text{min}$ | $V_{OH} = V_{DD} - 0.5\text{V}$ | -1.1 | | | mA |
| | I_{OL} | | $V_{OL} = 0.4\text{V}$ | 3.7 | | | |
| | I_{OZH} | $\overline{OE} = V_{DD}$ $V_{DD} = \text{max}$ | $V_{OH} = V_{DD}$ | | | 16 | μA |
| | I_{OZL} | | $V_{OL} = 0\text{V}$ | | | 16 | |

Timing

($F_c = 20\text{MSPS}$, $V_{DD} = 4.75$ to 5.25V , $V_{RB} = 0.5\text{V}$, $V_{RT} = 2.5\text{V}$, $T_a = -40$ to $+85^\circ\text{C}$)

| Item | Symbol | Conditions | Min. | Typ. | Max. | Unit |
|-------------------------------|-----------|--|------|------|------|------|
| Output data delay | T_{DL} | With TTL 1 gate and 10pF load | | 18 | 30 | ns |
| Tri-state output enable time | t_{PZH} | $R_L = 1\text{k}\Omega$, $C_L = 20\text{pF}$ $\overline{OE} = 5\text{V} \rightarrow 0\text{V}$ | 3 | 7 | 13 | ns |
| | t_{PZL} | | | | | |
| Tri-state output disable time | t_{PHZ} | $R_L = 1\text{k}\Omega$, $C_L = 20\text{pF}$ $\overline{OE} = 0\text{V} \rightarrow 5\text{V}$ | 7 | 15 | 26 | ns |
| | t_{PLZ} | | | | | |

Electrical Characteristics Measurement Circuit

Integral non-linearity error } measurement circuit
 Differential non-linearity error }
 Offset voltage }

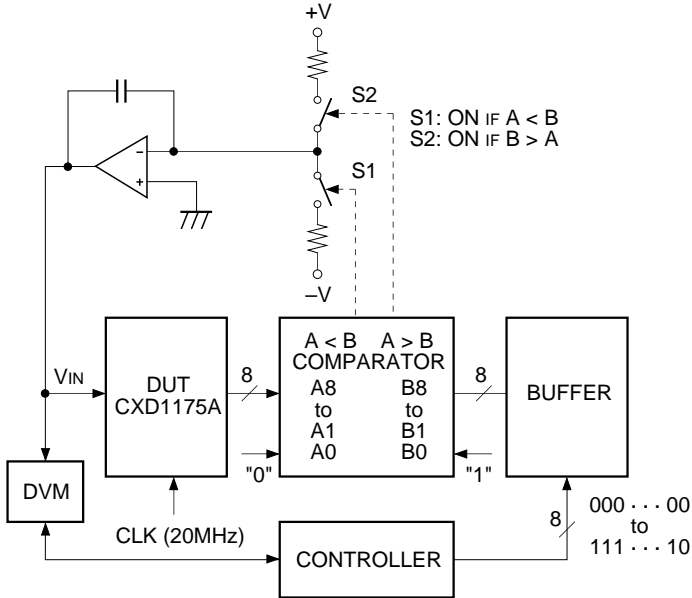

3-state output measurement circuit

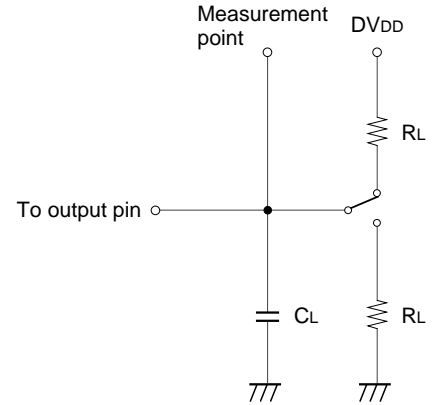

Note) C_L includes the capacitance of the probe and others.

Maximum operational speed } measurement circuit
 Differential gain error }
 Differential phase error }

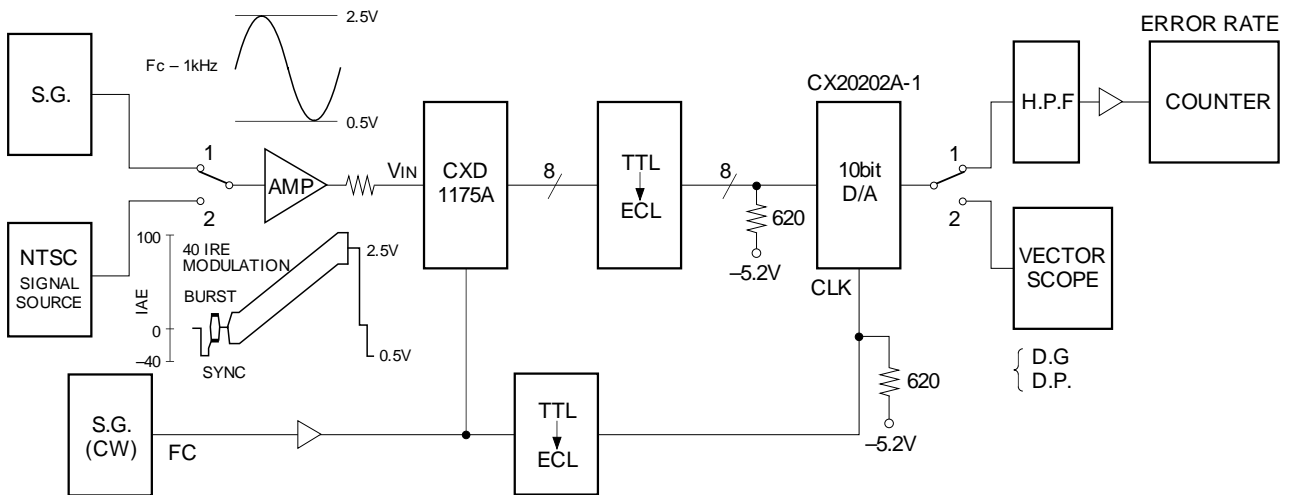

Digital output current measurement circuit

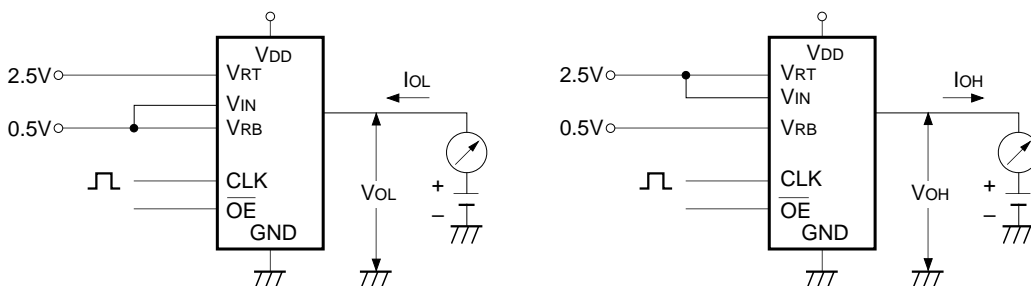

Timing Chart 3

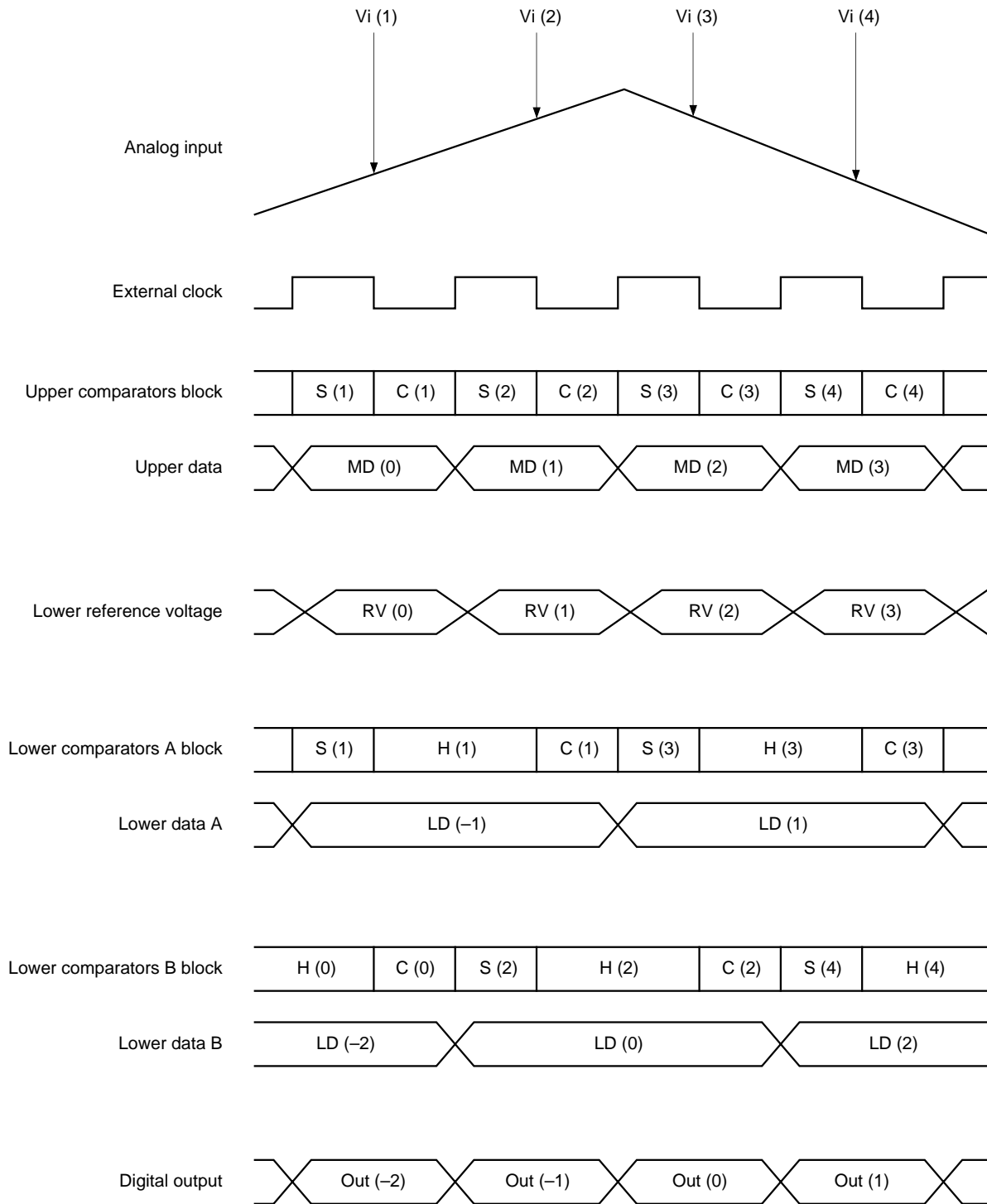

Operation (See Block Diagram and Timing Chart)

1. The CXD1175AM/AP is a 2-step parallel system A/D converter featuring a 4-bit upper comparators group and 2 lower comparators groups of 4-bit each. The reference voltage that is equal to the voltage between $V_{RT} - V_{RB}/16$ is constantly applied to the upper 4-bit comparator block. Voltage that corresponded to the upper data is fed through the reference supply to the lower data. V_{RTS} and V_{RBS} pins serve for the self generation of V_{RT} (Reference voltage top) and V_{RB} (Reference voltage bottom).

2. This IC uses an offset cancel type comparator and operates synchronously with an external clock. It features the following operating modes which are respectively indicated on the timing chart with S, H, C symbols. That is input sampling (auto zero) mode, input hold mode and comparison mode.
3. The operation of respective parts is as indicated in the chart. For instance input voltage V_i (1) is sampled with the falling edge of the first clock by means of the upper comparator block and the lower comparator A block.
The upper comparators block finalizes comparison data MD (1) with the rising edge of the first clock. Simultaneously the reference supply generates the lower reference voltage RV (1) that corresponded to the upper results. The lower comparator block finalizes comparison data LD (1) with the rising edge of the second clock. MD (1) and LD (1) are combined and output as Out (1) with the rising edge of the 3rd clock. Accordingly there is a 2.5 clock delay from the analog input sampling point to the digital data output.

Operation Notes

1. V_{DD} , V_{SS}
To reduce noise effects, separate the analog and digital systems close to the device. For both the digital and analog V_{DD} pins, use a ceramic capacitor of about $0.1\mu\text{F}$ set as close as possible to the pin to bypass to the respective GND's.
2. Analog input
Compared with the flash type A/D converter, the input capacitance of the analog input is rather small. However it is necessary to conduct the drive with an amplifier featuring sufficient band and drive capability. When driving with an amplifier of low output impedance, parasite oscillation may occur. That may be prevented by inserting a resistance of about 100Ω in series between the amplifier output and A/D input.
3. Clock input
The clock line wiring should be as short as possible also, to avoid any interference with other signals, separate it from other circuits.
4. Reference input
Voltage between V_{RT} to V_{RB} is compatible with the dynamic range of the analog input. Bypassing V_{RT} and V_{RB} pins to GND, by means of a capacitor about $0.1\mu\text{F}$, stable characteristics are obtained. By shorting V_{RT} and V_{RTS} , V_{RB} and V_{RBS} , the self-bias function that generates $V_{RT} = 2.6\text{V}$ and $V_{RB} = 0.6\text{V}$, is activated.
5. Timing
Analog input is sampled with the falling edge of CLK and output as digital data with a delay of 2.5 clocks and with the following rising edge. The delay from the clock rising edge to the data output is about 18ns.
6. $\overline{\text{OE}}$ pin
By connecting $\overline{\text{OE}}$ to GND output mode is obtained. By connecting to V_{DD} high impedance is obtained.
7. About latch up
It is necessary that AV_{DD} and DV_{DD} pins be the common source of power supply.
This is to avoid latch up due to the voltage difference between AV_{DD} and DV_{DD} pins when power is ON.

Application Circuit

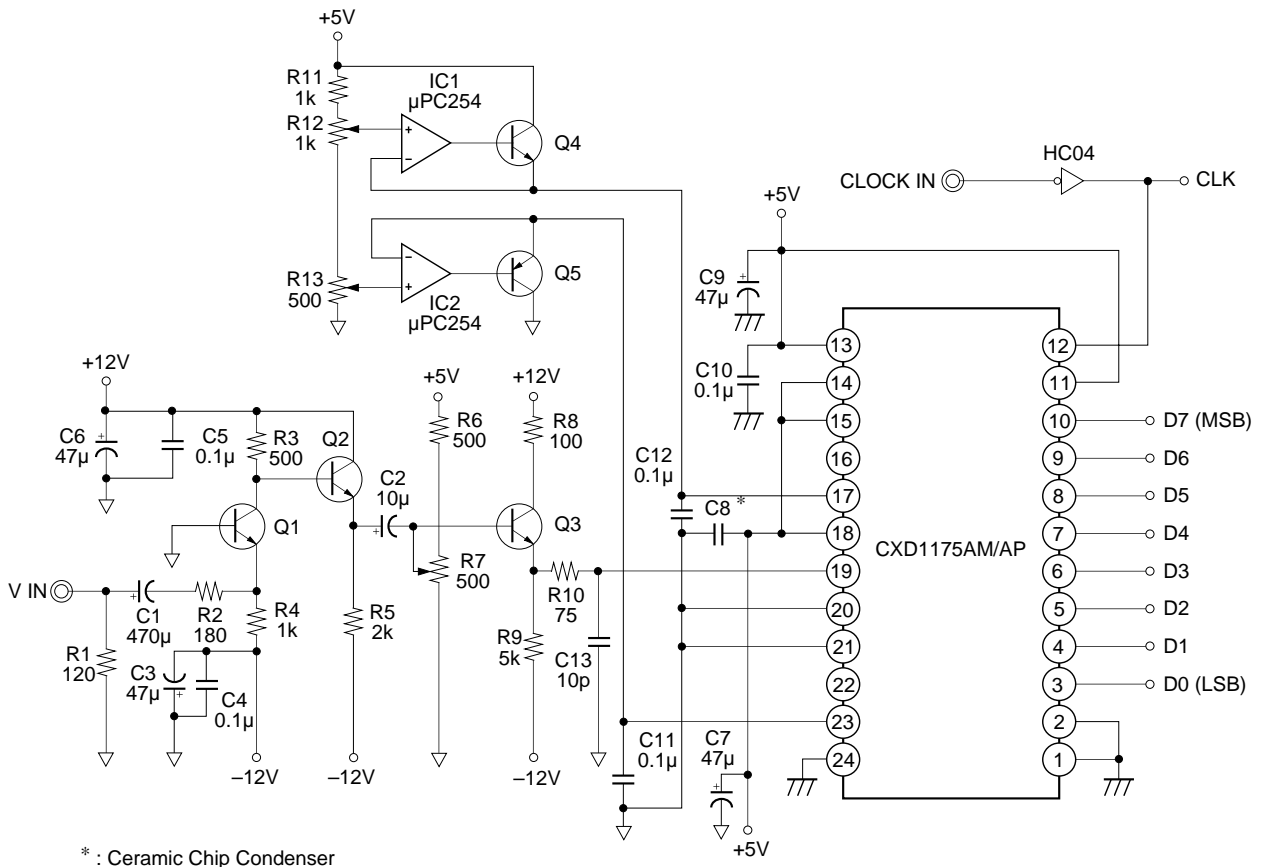

* : Ceramic Chip Condenser
0.1μF

▽ : Analog GND

⏏ : Digital GND

Note) It is necessary that AV_{DD} and DV_{DD} pins the common source of power supply.
The gain of analog input signal can be variable by adjustment of value of R3.

Application circuits shown are typical examples illustrating the operation of the devices. Sony cannot assume responsibility for any problems arising out of the use of these circuits or for any infringement of third party patent and other right due to same.

8-bit 20MSPS ADC and DAC Evaluation Board

The CXD1175AP/CXA1106P PCB is evaluation PCB for the 8-bit high speed and low power consumption CMOS A/D converter CXD1175AP and the 8-bit high speed bipolar D/A converter CXA1106P. This PCB features a high speed and low power consumption CMOS A/D converter, analog input buffer, clock buffer, latch and high speed bipolar D/A converter designed to fully enhance the performance of A/D and D/A converters.

Block Diagram

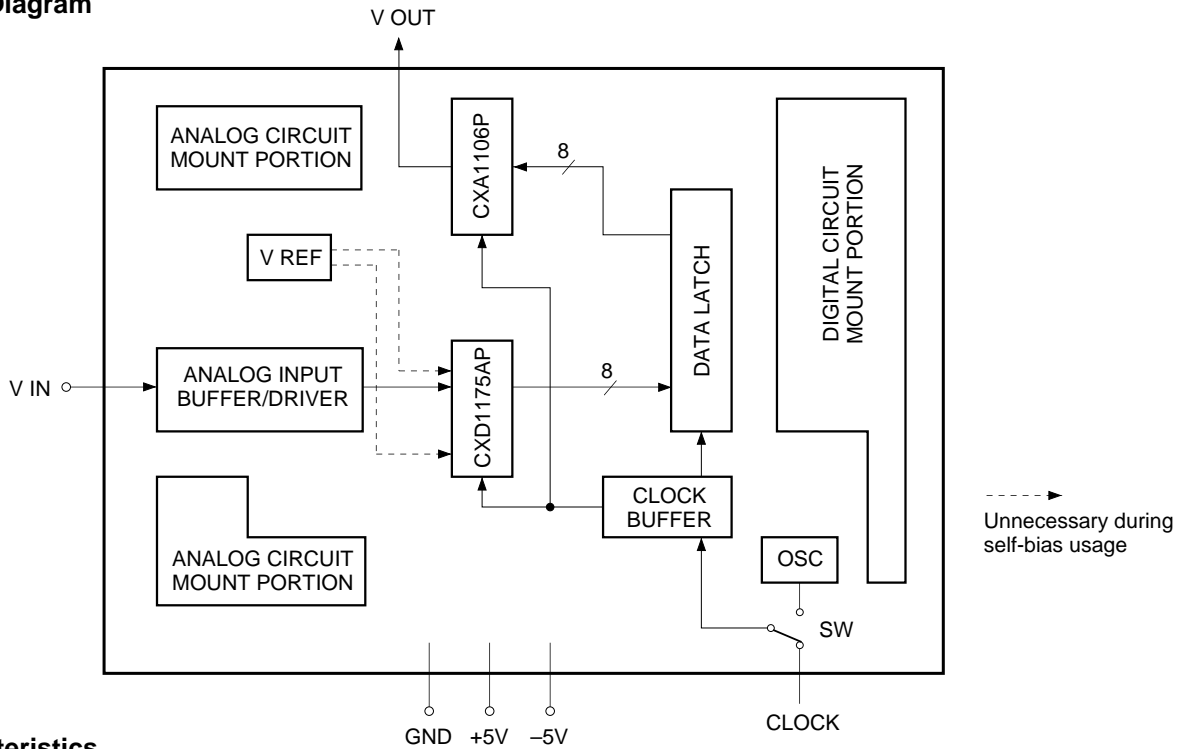

Characteristics

- Resolution 8bit
- Maximum conversion rate 20MHz
- Digital input level TTL level
- Supply voltage $\pm 5.0V$

Supply voltage

| Item | Min. | Typ. | Max. | Unit |
|------|------|------|------|------|
| +5V | | | 150 | mA |
| -5V | | | 20 | |

Analog input

AC input voltage

| Item | Min. | Typ. | Max. | Unit |
|-----------------------------------|------|------|------|------|
| Gain ($V_{IN} = 2V_{p-p}$ input) | 0.5 | | 2 | |
| Offset voltage | 0 | | 5 | V |

Clock input

TTL compatible

- Pulse width T_{CW1} 25ns (min.)
- T_{CW0} 25ns (min.)

Analog Output (CXA1106) (RL > 10kΩ)

| Item | Min. | Typ. | Max. | Unit |
|---------------|------|------|------|------|
| Analog output | 0.9 | 1.0 | 1.1 | V |

Output Format (CXD1175A)

The table shows the output format of A/D converter.

| Input signal voltage | Step | Digital output code | | | | | | | |
|----------------------|------|---------------------|---|---|---|-----|---|---|---|
| | | MSB | | | | LSB | | | |
| V _{RT} | 0 | 1 | 1 | 1 | 1 | 1 | 1 | 1 | 1 |
| ⋮ | ⋮ | ⋮ | | | | | | | |
| ⋮ | 127 | 1 | 0 | 0 | 0 | 0 | 0 | 0 | 0 |
| ⋮ | 128 | 0 | 1 | 1 | 1 | 1 | 1 | 1 | 1 |
| ⋮ | ⋮ | ⋮ | | | | | | | |
| V _{RB} | 255 | 0 | 0 | 0 | 0 | 0 | 0 | 0 | 0 |

Timing Chart

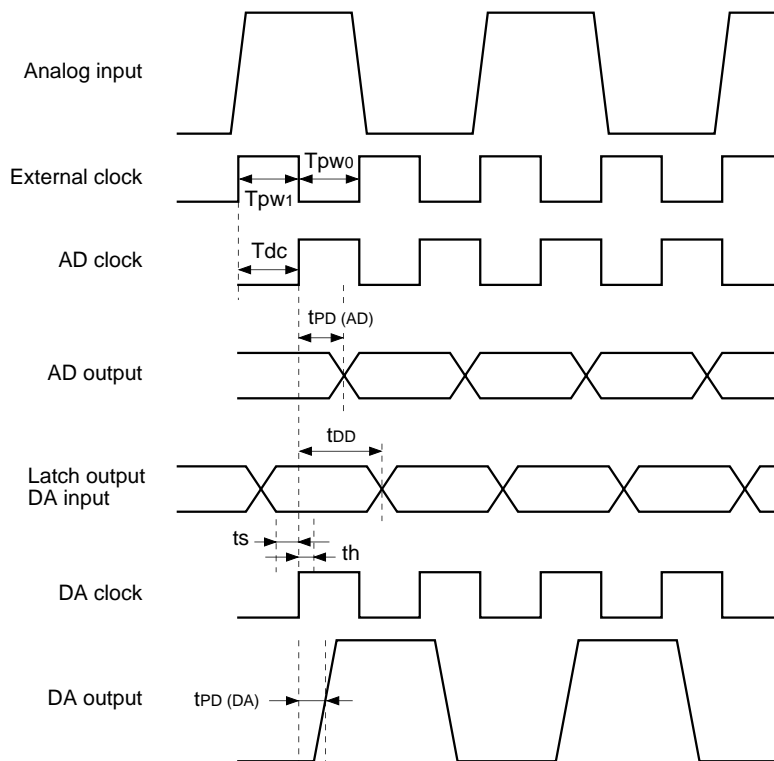

| Item | Symbol | Min. | Typ. | Max. | Unit |
|--------------------|---------------------|------|------|------|------|
| Clock high time | T _{PW1} | 25 | | | ns |
| Clock low time | T _{PW0} | 25 | | | ns |
| Clock delay | T _{dc} | | | 24 | ns |
| Data delay AD | t _{PD(AD)} | | 18 | 30 | ns |
| Data delay (latch) | t _{DD} | | | 17 | ns |
| Set up time | t _s | 10 | | | ns |
| Hold time | t _h | 2 | | | ns |
| Data delay DA | t _{PD(DA)} | | 11 | | ns |

Peripheral Circuit Board (Top View)

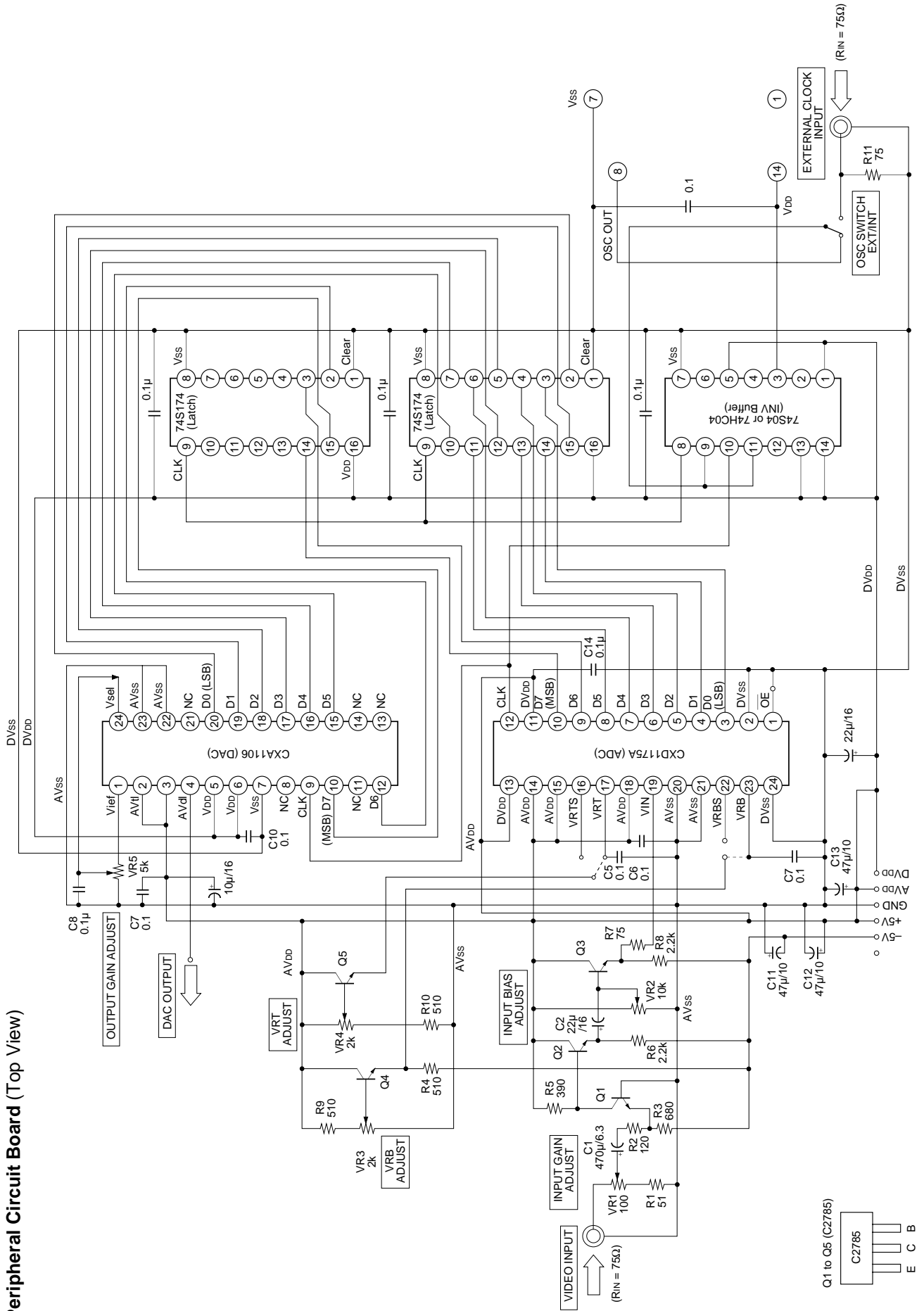

List of Parts

| | | | |
|------------------|-----------------------|-------------------|---------|
| resistor | | transistor | |
| R1 | 51Ω | Q1 | 2SC2785 |
| R2 | 120Ω | Q2 | 2SC2785 |
| R3 | 680Ω | Q3 | 2SC2785 |
| R4 | 510Ω | Q4 | 2SC2785 |
| R5 | 390Ω | Q5 | 2SC2785 |
| R6 | 2.2kΩ | | |
| R7 | 75Ω | IC | |
| R8 | 2.2kΩ | IC1 | 74S174 |
| R9 | 510Ω | IC2 | 74S174 |
| R10 | 510Ω | IC3 | 74S04 |
| R11 | 75Ω | | |
| VR1 | 100Ω | oscillator | |
| VR2 | 10kΩ | OSC | |
| VR3 | 2kΩ | | |
| VR4 | 2kΩ | others | |
| VR5 | 5kΩ | connector | BNC071 |
| | | SW | AT1D2M3 |
| capacitor | | | |
| C1 | 470μF/6.3V (chemical) | | |
| C2 | 22μF/16V (chemical) | | |
| C3 | 0.01μF | | |
| C4 | 10μF/16V (tantalate) | | |
| C5 | 0.1μF | | |
| C6 | 0.1μF | | |
| C7 | 0.1μF | | |
| C8 | 0.1μF | | |
| C9 | 0.1μF | | |
| C10 | 0.1μF | | |
| C11 | 47μF/10V (chemical) | | |
| C12 | 47μF/10V (chemical) | | |
| C13 | 47μF/10V (chemical) | | |
| C14 | 0.1μF | | |

Method of Adjustment

1. Vgain (VR1)
Gain adjustment of the analog input.
2. Voffset (VR2)
Offset adjustment of the analog input.
3. Vref (VR3, VR4)
Adjustment of the A/D converter reference voltage.
VRB is adjusted at VR3, and VRT at VR4. Reference voltage is given with self-bias for PCB shipment.
4. Analog output gain (VR5)
Full-scale voltage of the D/A converter output is adjusted.

Points on the PCB Pattern Layout

1. Layout so that digital current does not flow to analog GND (part 1).
(See Component Side on page 19 for part 1.)
2. Capacitor C6 (between AV_{SS} and AV_{DD}) and capacitor C14 (between DV_{SS} and DV_{DD}) are important factors to enhance the CXD1175A performance. Those capacitors should feature good high frequency characteristics over 0.1 μ F (ceramic capacitor). Layout as close to the IC as possible.
3. Analog GND (AV_{SS}) and Digital GND (DV_{SS}) have a common voltage and a supply source. The DV_{SS} of A/D converter (part 2) location as close to the voltage source is possible will give even better results. That is, a layout where the A/D converter is close to the voltage source is recommended. (See Component Side on page 19 for part 2.)
4. AV_{DD} (Pins 14, 15 and 18) and DV_{DD} (Pins 11 and 13) are provided in the CXD1175A, and a common voltage source should be used for them as for part 3. (See the paragraph for Latch Up Prevention.) (See Soldering Side on page 19 for part 3.)
5. The A/D converter samples analog signals at the falling edge of clock. Accordingly, clocks fed to the A/D converter should not be affected by jitter.
6. In this PCB, to evaluate A/D and D/A converters independently, an independent layout has been adopted for the analog GND of A/D and D/A converters, from the voltage generation source. For the user's actual PCB even a common source poses no problems. For the CXA1106, as analog signals are output with the supply voltage as reference, take care not to let noise interfere with the analog V_{DD} of D/A converter.

Notes on Operation

1. Reference voltage

The self-bias function where $V_{RT} = 2.6V$ and $V_{RB} = 0.6V$ is available by shorting V_{RT} and V_{RTS} , V_{RB} and V_{RBS} in the CXD1175A. At the PCB, either self-bias or external reference voltage can be selected according to the way the jumper wire is connected. For shipment, the reference voltage is provided by the self-bias. Also, when reference voltage is to be provided from the exterior, adjust the dynamic range ($V_{RT} - V_{RB}$) to 1.8Vp-p or over.

2. Clock input

There are two modes for the PCB clock input.

- 1) Through an external signal generator (external clock)
- 2) Using a crystal oscillator (internal clock)

These two modes can be selected with a switch on the PCB.

They are given from the external clock for shipment.

3. Peripheral through hole

There is a number of through holes at the analog input, output and LOGIC areas. Those are used when additional circuits are to be mounted on the PCB circuit.

4 The two latch ICs (74S174) on the circuit diagram are not absolutely necessary for the A/D and D/A converter evaluation. That is, when the A/D converter output data is directly input to D/A converter input, normal operation is maintained. However, as A/D converter output data is hardly ever subject to D/A conversion without the digital signal processing, the PCB has been fitted with the 74S174 to show a layout example for digital signal processing IC.

5. Analog input buffer & driver block is designed to handle conventional video band signals. Accordingly, for tests involving frequencies higher than that, methods shown in the figure below are recommended.

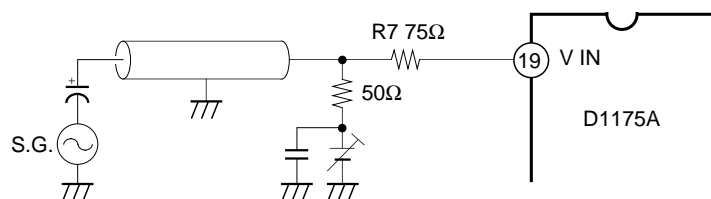

High frequency input measurement circuit

Latch Up Prevention

The CXD1175A is a CMOS IC which requires latch up precautions. Latch up is mainly generated by the lag in the voltage rising time of AV_{DD} (Pins 14, 15 and 18) and DV_{DD} (Pins 11 and 13), when power supply is ON.

1. Correct usage

a. When analog and digital supplies are from different sources

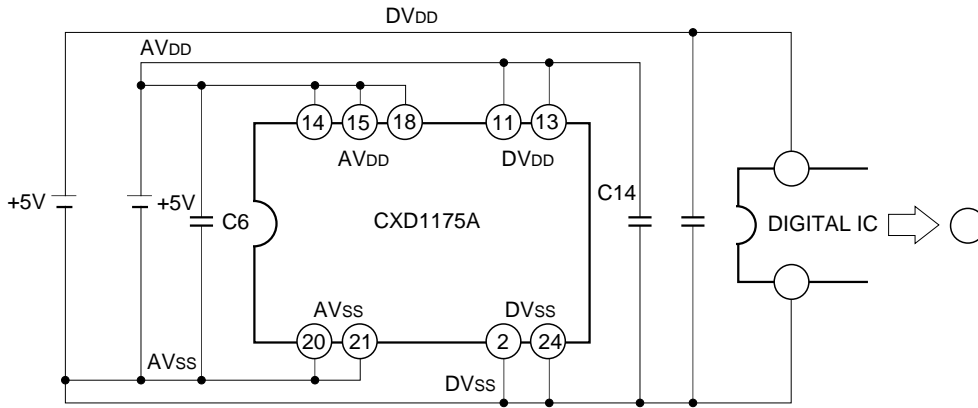

b. When analog and digital supplies are from a common source

(i)

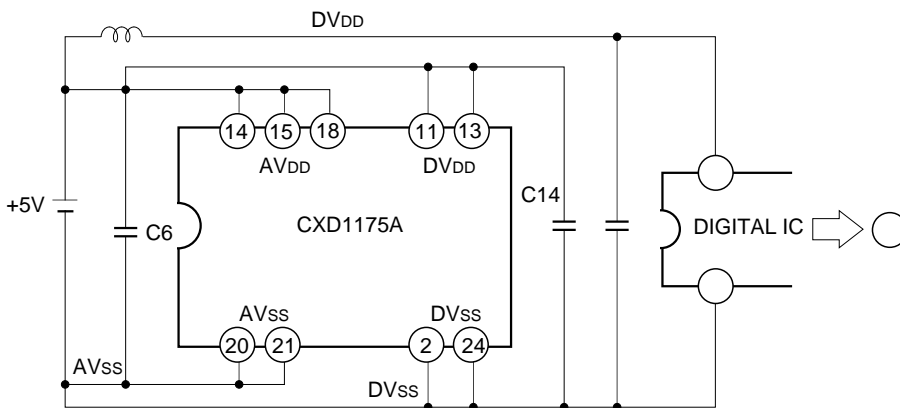

(ii)

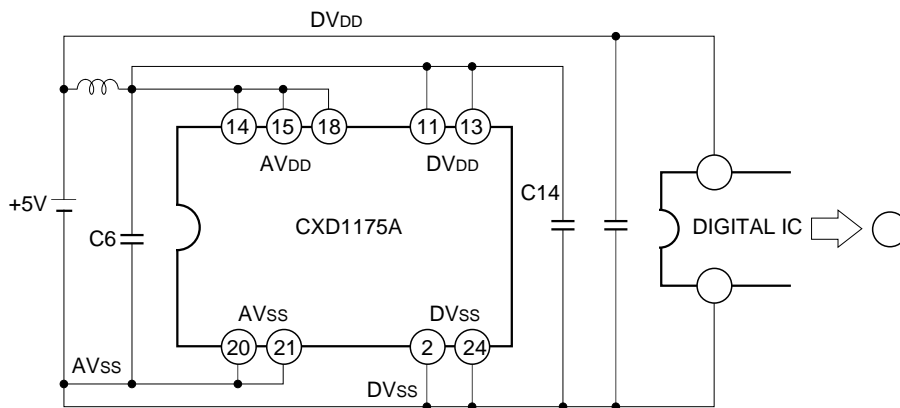

2. Example when latch up easily occurs

a. When analog and digital supplies are from different sources

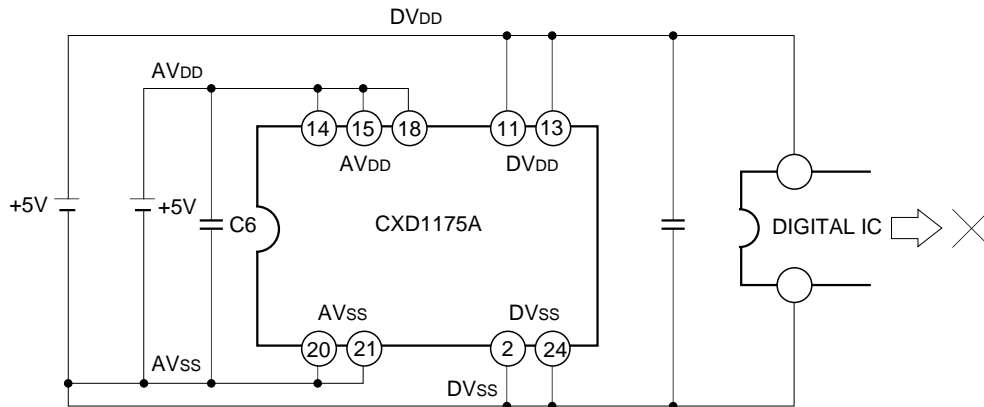

b. When analog and digital supplies are from common source

(i)

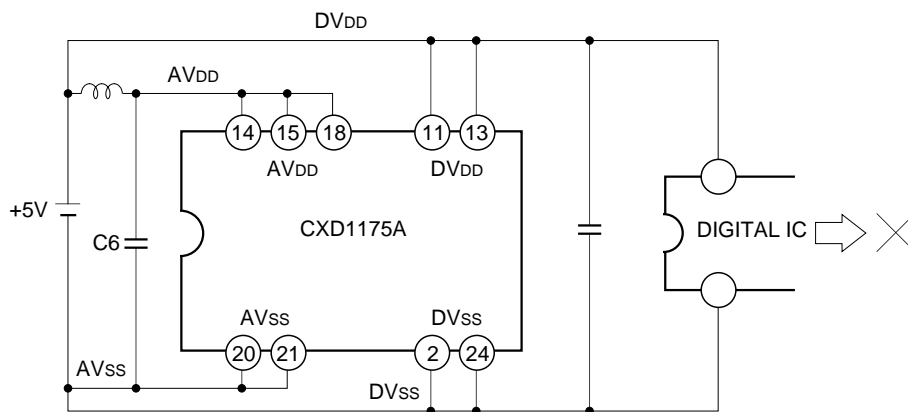

(ii)

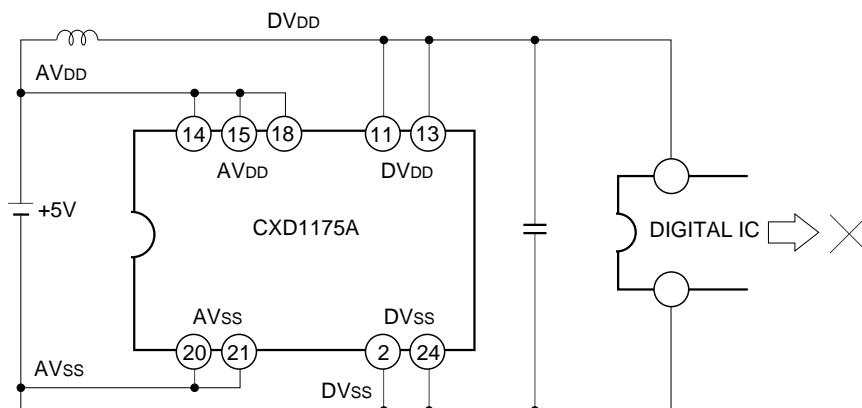

Silk Side

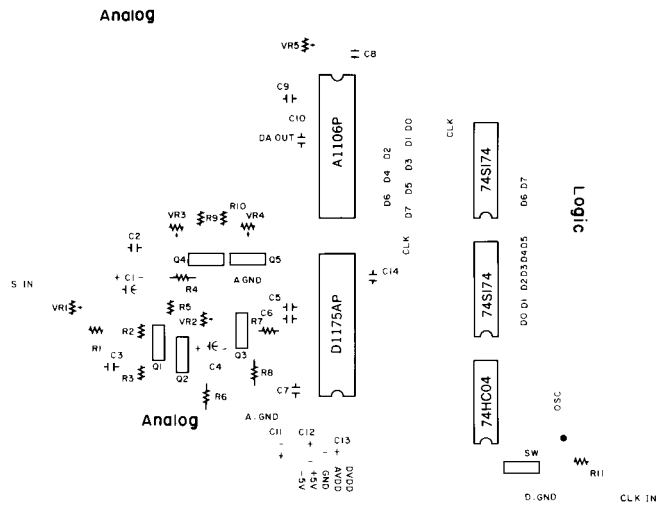

Component side

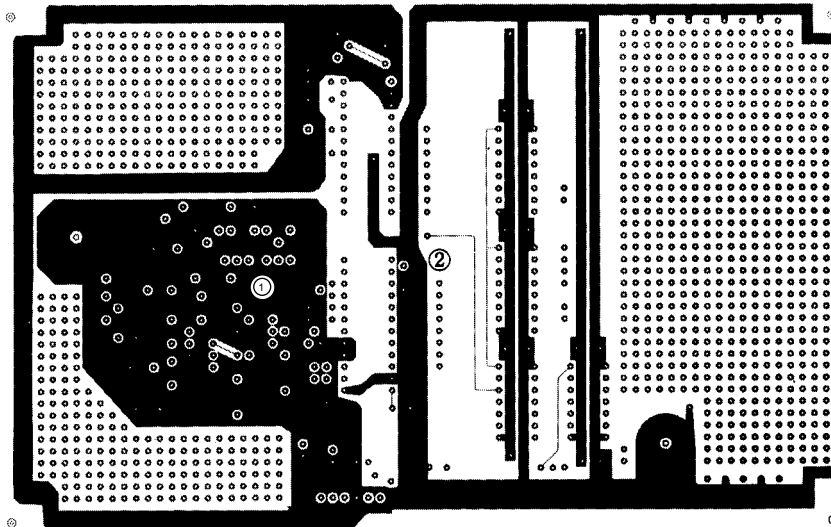

Soldering side

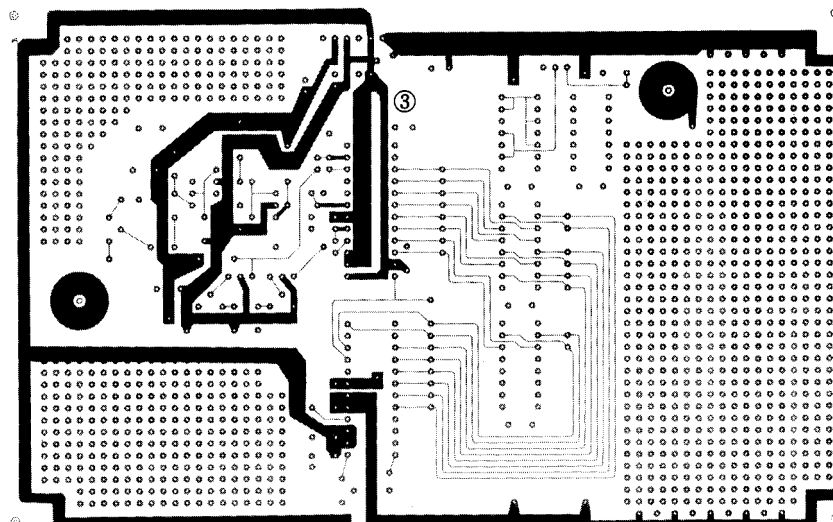

Package Outline

Unit: mm
CXD1175AM

24PIN SOP (PLASTIC)

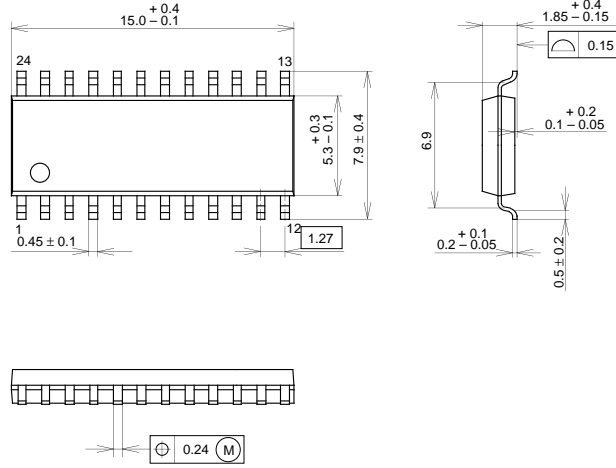

PACKAGE STRUCTURE

| | |
|------------|---------------|
| SONY CODE | SOP-24P-L01 |
| EIAJ CODE | SOP024-P-0300 |
| JEDEC CODE | — |

| | |
|------------------|-----------------|
| MOLDING COMPOUND | EPOXY RESIN |
| LEAD TREATMENT | SOLDER PLATING |
| LEAD MATERIAL | 42/COPPER ALLOY |
| PACKAGE MASS | 0.3g |

24PIN SOP (PLASTIC)

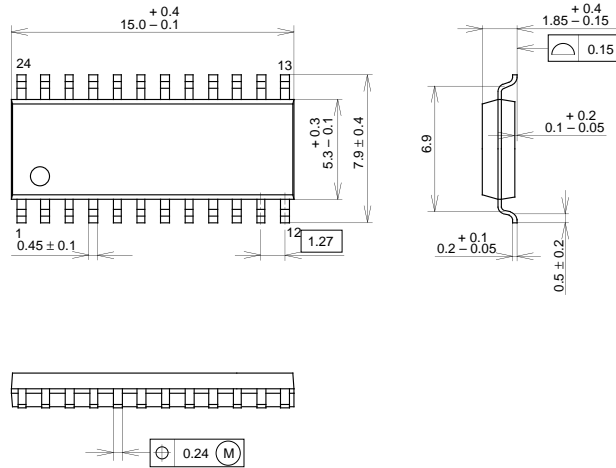

PACKAGE STRUCTURE

| | |
|------------|---------------|
| SONY CODE | SOP-24P-L01 |
| EIAJ CODE | SOP024-P-0300 |
| JEDEC CODE | — |

| | |
|------------------|-----------------|
| MOLDING COMPOUND | EPOXY RESIN |
| LEAD TREATMENT | SOLDER PLATING |
| LEAD MATERIAL | 42/COPPER ALLOY |
| PACKAGE MASS | 0.3g |

LEAD SPECIFICATIONS

| ITEM | SPEC. |
|--------------------------|--------------|
| LEAD MATERIAL | COPPER ALLOY |
| LEAD TREATMENT | Sn-Bi 2.5% |
| LEAD TREATMENT THICKNESS | 5-18 μ m |

Package Outline

Unit: mm
CXD1175AP

24PIN DIP(PLASTIC)

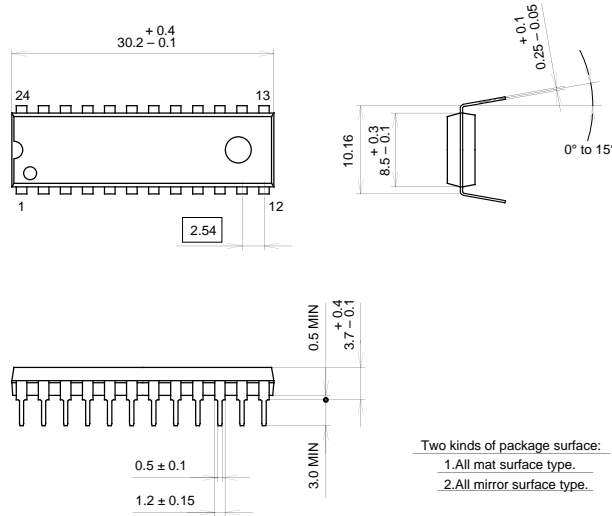

PACKAGE STRUCTURE

| | |
|------------|---------------|
| SONY CODE | DIP-24P-01 |
| EIAJ CODE | DIP024-P-0400 |
| JEDEC CODE | |

| | |
|------------------|-----------------|
| PACKAGE MATERIAL | EPOXY RESIN |
| LEAD TREATMENT | SOLDER PLATING |
| LEAD MATERIAL | 42/COPPER ALLOY |
| PACKAGE MASS | 2.0g |

24PIN DIP(PLASTIC)

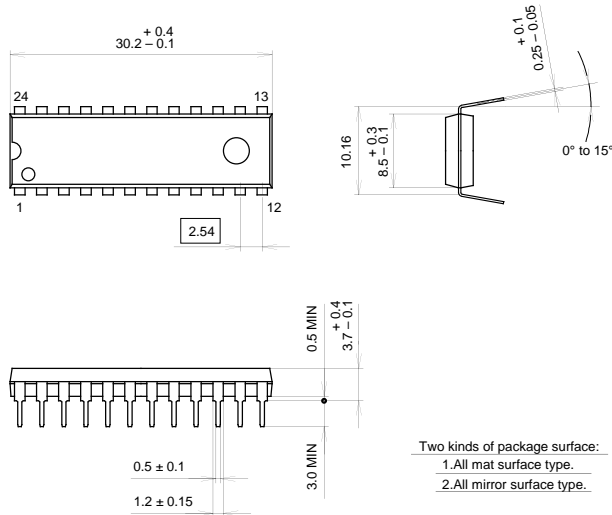

PACKAGE STRUCTURE

| | |
|------------|---------------|
| SONY CODE | DIP-24P-01 |
| EIAJ CODE | DIP024-P-0400 |
| JEDEC CODE | |

| | |
|------------------|-----------------|
| PACKAGE MATERIAL | EPOXY RESIN |
| LEAD TREATMENT | SOLDER PLATING |
| LEAD MATERIAL | 42/COPPER ALLOY |
| PACKAGE MASS | 2.0g |

LEAD SPECIFICATIONS

| ITEM | SPEC. |
|--------------------------|--------------|
| LEAD MATERIAL | COPPER ALLOY |
| LEAD TREATMENT | Sn-Bi 2.5% |
| LEAD TREATMENT THICKNESS | 5-18 μ m |



LittleDiode supplies new, hard to find or obsolete electronic components and semiconductors all over the world.

With over two million different components listed you are sure to find the part you need.

Feel free to visit us today at our online store:

LittleDiode.com

Looking forward to providing you with the best possible service.