

**Digital Comb Filter (NTSC)**

**Description**

The CXD2073S is an adaptive comb filter compatible with NTSC system, and provide high-precision Y/C separation with a single chip.

**Features**

- Y/C separation by adaptive processing
- Horizontal aperture compensation circuit
- 8-bit A/D converter (1 channel)
- 8-bit D/A converter (2 channels)
- One 1H delay line
- Clamp circuit

**Absolute Maximum Ratings** (Ta = 25°C, Vss = 0V)

- Supply voltage
 

DVDD	Vss – 0.5 to +7.0	V
DAVD	Vss – 0.5 to +7.0	V
ADVD	Vss – 0.5 to +7.0	V
PLVD	Vss – 0.5 to +7.0	V
- Input voltage
 

Vi	Vss – 0.5 to VDD +0.5	V
----	-----------------------	---
- Output voltage
 

Vo	Vss – 0.5 to VDD +0.5	V
----	-----------------------	---
- Operating temperature
 

Topr	–20 to +75	°C
------	------------	----
- Storage temperature
 

Tstg	–55 to +150	°C
------	-------------	----

**Recommended Operating Conditions**

- Supply voltage
 

DVDD	5.0 ± 0.25	V
DAVD	5.0 ± 0.25	V
ADVD	5.0 ± 0.25	V
PLVD	5.0 ± 0.25	V
- Operating temperature
 

Topr	–20 to +75	°C
------	------------	----

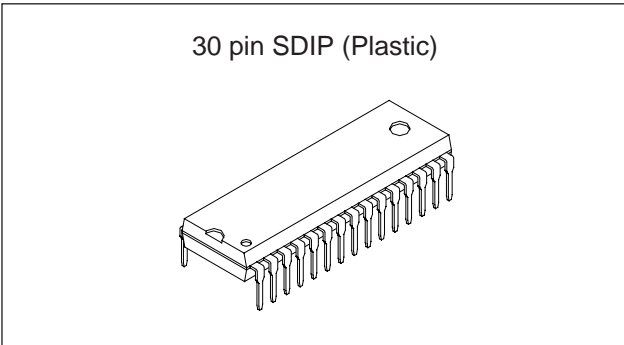

**Structure**

Silicon gate CMOS IC

**Applications**

Y/C separation for color TVs and VCRs

Sony reserves the right to change products and specifications without prior notice. This information does not convey any license by any implication or otherwise under any patents or other right. Application circuits shown, if any, are typical examples illustrating the operation of the devices. Sony cannot assume responsibility for any problems arising out of the use of these circuits.

Pin Configuration (Top View)

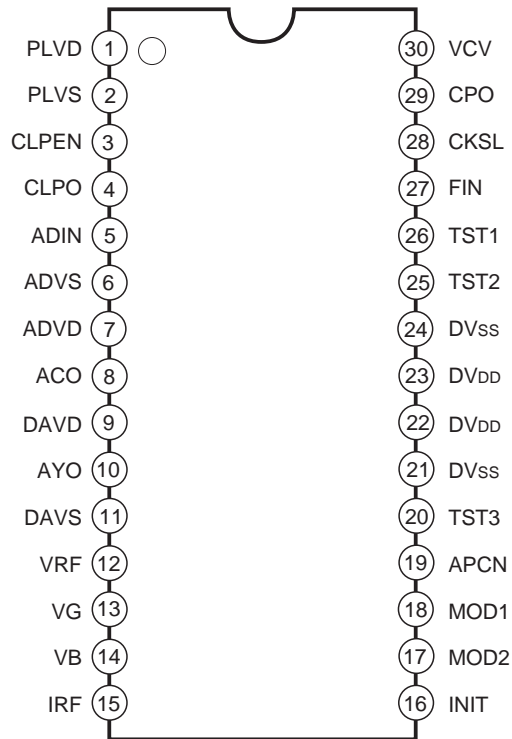

Block Diagram

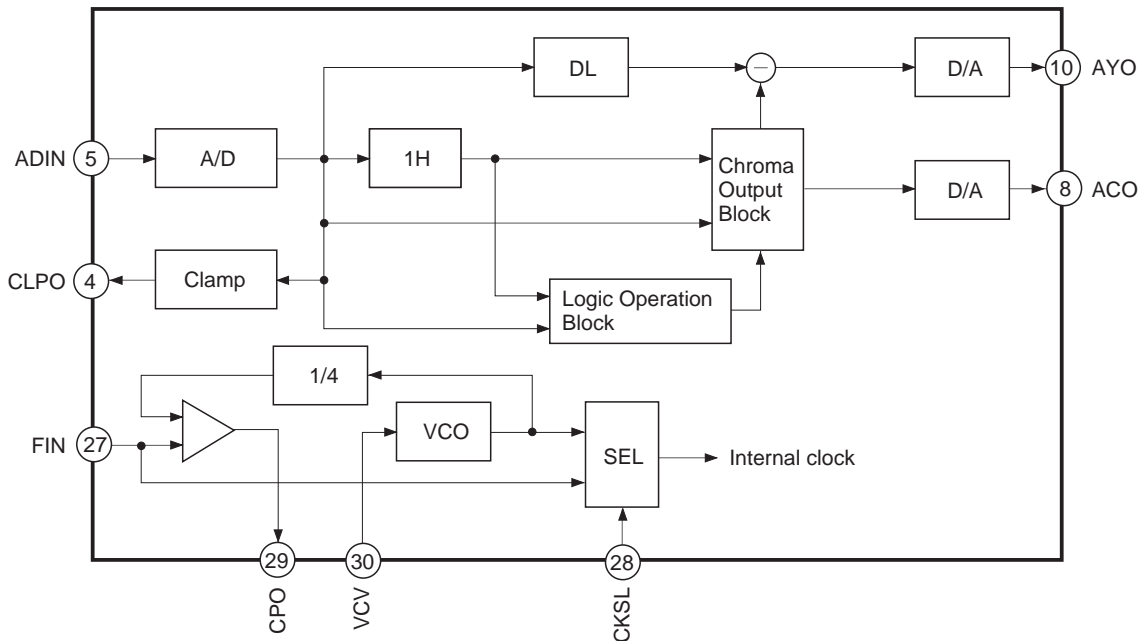

## Pin Description

Pin No.	Symbol	I/O	Description
1	PLVD	—	Analog power supply for PLL (+5V)
2	PLVS	—	Analog ground for PLL
3	CLPEN	I	Clamp enable L: Clamp function is enabled. Set to L when the internal clamp is used. H: Clamp function is disabled. Set to H when the internal clamp is not used.
4	CLPO	O	Connect to ADIN when clamp circuit is used. Leave this pin open when clamp circuit is not used.
5	ADIN	I	Comb filter analog input (A/D converter input)
6	ADVS	—	Analog ground for A/D converter
7	ADVD	—	Analog power supply for A/D converter (+5V)
8	ACO	O	Analog chroma signal output
9	DAVD	—	Analog power supply for D/A converter (+5V)
10	AYO	O	Analog luminance signal output
11	DAVS	—	Analog ground for D/A converter
12	VRF	I	D/A converter reference voltage setting. Sets the full-scale value for D/A converter.
13	VG	O	Connect to DAVD via a capacitor of approximately 0.1 $\mu$ F.
14	VB	O	Connect to DAVS via a capacitor of approximately 0.1 $\mu$ F.
15	IRF	O	Connect a resistor of 16 times (16R) that of the output resistor "R" of AYO pin.
16	INIT	I	Test. Normally, fix to Low.
17	MOD2	I	Y/C separation status setting pins MOD2 MOD1
18	MOD1	I	L L Adaptive processing mode L H BPF separation fixed mode H L Y through mode H H Simple comb mode
19	APCN	I	Aperture compensation switching L: Aperture compensation OFF H: Aperture compensation ON
20	TST3	O	Test. Normally, leave this pin open.
21	DVss	—	Digital ground
22	DVDD	—	Digital power supply (+5V)
23	DVDD	—	Digital power supply (+5V)
24	DVss	—	Digital ground
25	TST2	O	Test. Normally, leave this pin open.
26	TST1	I	Test. Normally, fix to Low.
27	FIN	I	Clock input. Input burst-locked clock. Input fsc when the PLL is used. Input 4fsc when the PLL is not used.
28	CKSL	I	PLL control. L: When the PLL is not used. The 4fsc clock input to FIN is supplied internally. H: When the PLL is used. The 4fsc clock from VCO oscillation output is supplied internally.
29	CPO	O	Phase comparison output for the internal PLL. Leave open when the PLL is not used.
30	VCV	I	VCO oscillation control voltage input for the internal PLL. Connect to PLVS when the PLL is not used.

**Electrical Characteristics**(V<sub>DD</sub> = 5 ± 0.25V, V<sub>SS</sub> = 0V, T<sub>a</sub> = -20 to +75°C)

Item	Symbol	Conditions	Min.	Typ.	Max.	Unit
Supply voltage	DV <sub>DD</sub>	—	4.75	5.0	5.25	V
	ADVD					
	DAVD					
	PLVD					
Operating temperature	Topr	—	-20	—	+75	°C
Supply current	I <sub>DD</sub>	Clock 14MHz	—	55	80	mA
High level input voltage	V <sub>IH</sub>	CMOS level (Pin 3, 16 to 19, 26, 28)	V <sub>DD</sub> × 0.7	—	V <sub>DD</sub>	V
Low level input voltage	V <sub>IL</sub>		V <sub>SS</sub>	—	V <sub>DD</sub> × 0.3	V
High level output voltage	V <sub>OH</sub>	I <sub>OH</sub> = -2mA (Pin 20 and 25)	V <sub>DD</sub> - 0.8	—	V <sub>DD</sub>	V
Low level output voltage	V <sub>OL</sub>	I <sub>OL</sub> = 4mA (Pin 20 and 25)	V <sub>SS</sub>	—	0.4	V
Logical V <sub>th</sub>	LV <sub>th</sub>	FIN (Pin 27)	—	V <sub>DD</sub> /2	—	V
Input voltage	V <sub>IN</sub>		0.5	—	V <sub>DD</sub>	V <sub>p-p</sub>
Feedback resistor	R <sub>FB</sub>		250k	1M	2.5M	Ω

**A/D Converter Characteristics**(V<sub>DD</sub> = 5V, T<sub>a</sub> = 25°C, f = 10MHz)

Item	Symbol	Conditions	Min.	Typ.	Max.	Unit
Resolution	n		—	8	—	bit
Max. conversion speed	f <sub>max</sub>		14.3	—	—	MSPS
Analog input band width	BW	-3dB	—	18	—	MHz
Input bias	BOTTOM		0.48	0.52	0.56	V
	TOP - BOTTOM		1.96	2.08	2.22	V
Differential linearity error	E <sub>D</sub>		-1.0	—	+1.0	LSB
Integral linearity error	E <sub>L</sub>		-3.0	—	+3.0	LSB

**D/A Converter Characteristics**(V<sub>DD</sub> = 5V, V<sub>RF</sub> = 2V, I<sub>RF</sub> = 3.3kΩ, R = 200Ω, T<sub>a</sub> = 25°C, f = 10MHz)

Item	Symbol	Conditions	Min.	Typ.	Max.	Unit
Resolution	n		—	8	—	bit
Max. conversion speed	f <sub>max</sub>	—	14.3	—	—	MSPS
Differential linearity error	E <sub>D</sub>	—	-0.8	—	+0.8	LSB
Integral linearity error	E <sub>L</sub>	—	-2.0	—	+2.0	LSB
Output full-scale voltage	V <sub>FS</sub>	—	1.805	1.90	1.995	V
Output full-scale current	I <sub>FS</sub>	—	—	9.5	15	mA
Output offset voltage	V <sub>OS</sub>	—	—	—	1.0	mV
Precision guaranteed output voltage range	V <sub>OC</sub>	—	1.8	—	2.1	V

**Clamp**(V<sub>DD</sub> = 5V, T<sub>a</sub> = 25°C, f = 10MHz)

Item	Symbol	Conditions	Min.	Typ.	Max.	Unit
Clamp level*1	CLV		—	0.67	—	V

\*1 Sync tip clamp

**Description of Functions**

## • Horizontal aperture compensation

Compensates aperture degradation accompanied by D/A conversion.

This compensation is effective for the following modes; adaptive processing, Y through, and simple comb modes.

## • Switching of Y/C separation modes

The following four modes can be set; however, the adaptive processing mode or Y through mode is normally used.

## (1) Adaptive processing mode

This mode detects interline correlation, switches between comb filter processing and BPF processing, and operates Y/C separation.

## (2) Y through mode

The composite video signal input from ADIN (Pin 5) is A/D converted. It is also D/A converted, and then output from AYO (Pin 10).

At this time, the output of ACO (Pin 8) is the same output as that of adaptive processing mode.

## (3) BPF mode

C signal is generated by passing composite video signal through BPF.

Y output is a signal in which the C signal generated is subtracted from input composite video signal.

## (4) Simple comb mode

Y/C separation is operated by the comb filter processing forcibly.

Modes	MOD1 (Pin 18)	MOD2 (Pin 17)
Adaptive processing mode	L	L
Y through mode	L	H
BPF mode	H	L
Simple comb mode	H	H

## • Selection Pin Setting Table

Pin No.	Symbol	H	L
3	CLPEN	Internal clamp not used	Internal clamp used
17 18	MOD2 MOD1	See the table above.	
19	APCN	Horizontal aperture compensation ON	Horizontal aperture compensation OFF
28	CKSL	Internal 4-multiple PLL used	Internal 4-multiple PLL not used

Application Circuit for D/A Converter

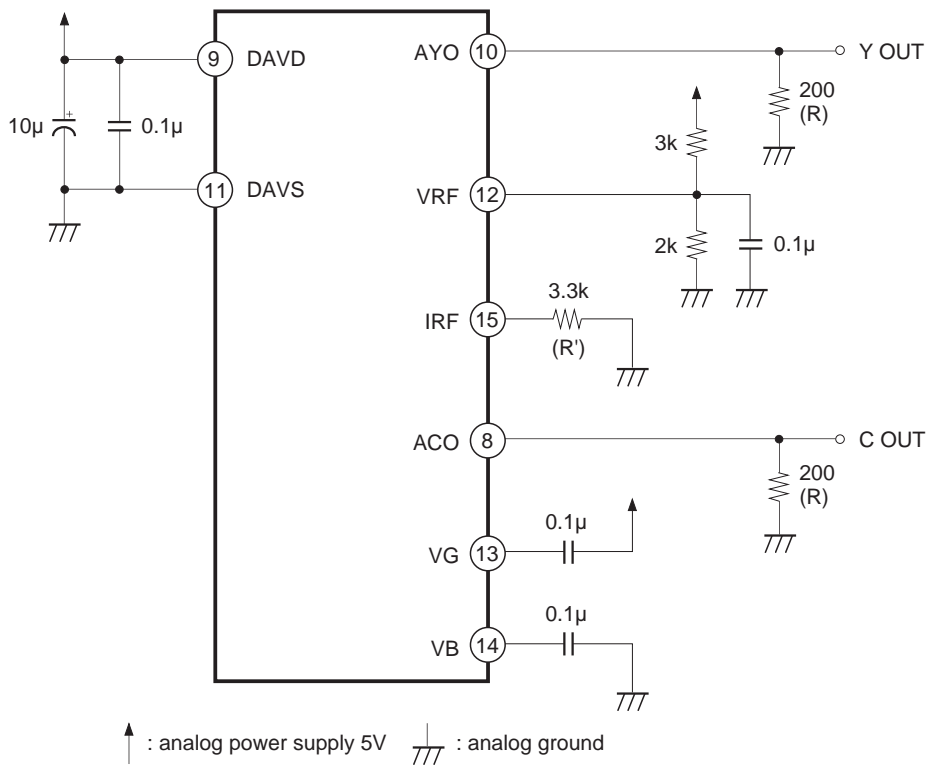

• Method of selecting output resistance

The CXD2073S has a built-in current output-type D/A converter. To obtain the output voltages, connect resistors to AYO and ACO pins.

$$VFS = IFS \times R$$

Here, VFS is output full-scale voltage, IFS is output full-scale current, and R is the output resistance connected to each IO.

In addition, connect a resistance of 16 times the output resistor to the reference current pin IRF. In the case where the value comes to be impractical, use a value of resistance as close to the value calculated as possible. At that time,

$$VFS = VRF \times 16 \times R/R'$$

R is the output resistance connected to each IO, R' is the resistance connected to IRF, and VRF is the VRF pin voltage. Power consumption can be reduced by using higher resistance values, but then glitch energy and data settling time increase contrastingly. Select optimum resistance values according to the system applications.

In case of the circuit above,  $VFS = 2 [V] \times 16 \times 0.2k/3.3k \approx 1.93 [V]$ ,  $IFS = 1.93/0.2k \approx 9.65 [mA]$ .

## Notes on Operation

- Power supply, ground

Separate the analog and digital systems around the device to reduce noise effect. Both analog and digital  $V_{DD}$  are respectively bypassed to  $V_{SS}$  as close to these  $V_{DD}$  and  $V_{SS}$  pins as possible through ceramic capacitors of approximately  $0.1\mu\text{F}$ .

Also, layout the power supply and ground pattern of the board substrate as wide as possible to lower impedance.

- Clock

Use the burst-locked clock. Separate the clock line on the board substrate as far as possible from analog-related pins, analog power supply, and analog ground.

- ADIN (analog input signal)

- (1) Low impedance drive

The input signal to ADIN (Pin 5) should be driven at the low impedance and its wiring should be as short as possible.

- (2) Input level

Set the input signal peak-to-peak value  $V_{PP}$  to 1.75V or less. Additionally,  $V_{PP}$  is recommended to be 1.3V or more since the A/D converter input dynamic range should be made as large as possible.

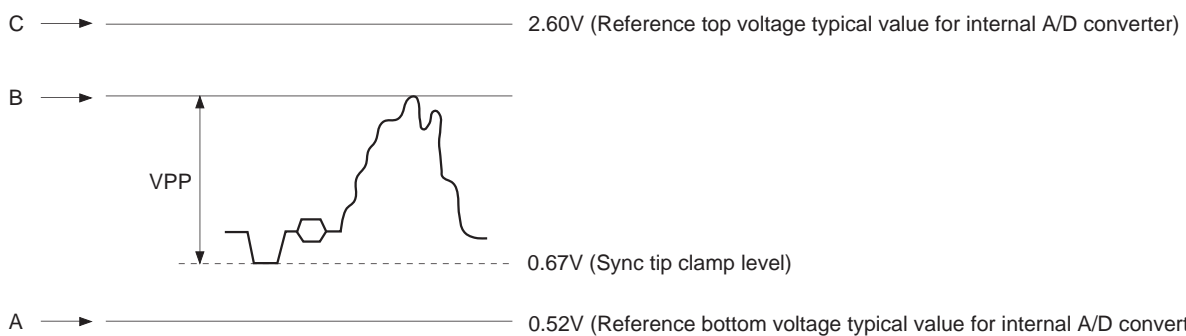

The DC level at the ADIN pin is as shown in the diagram above when the internal sync tip clamp is used.

Labeling the internal D/A converter AYO output full-scale voltage as  $V_{FS}$ , the correspondence between the ADIN pin voltage and AYO output pin voltage (DC level) is as follows;

DC voltage at point A → 0 [V]

DC voltage at point B → AYO maximum output voltage [V]

DC voltage at point C →  $V_{FS}$  [V]

The  $V_{FS}$  is the AYO output voltage generated when the voltage equivalent to the point C is input.

- Internal delay

The delay from the internal A/D converter to the D/A converter output is  $21.5 \text{ clocks} + \alpha \text{ ns}$  ( $\alpha$ : D/A converter analog output delay = approximately 20ns).

The 21.5 clocks are the sum of the clocks shown below;

A/D converter: 3.5 clocks ("0.5" is for fetching the data at the fall of the clock.)

Internal logic : 17 clocks

D/A converter: 1 clock

Application Circuit

(1) When the fsc clock is used

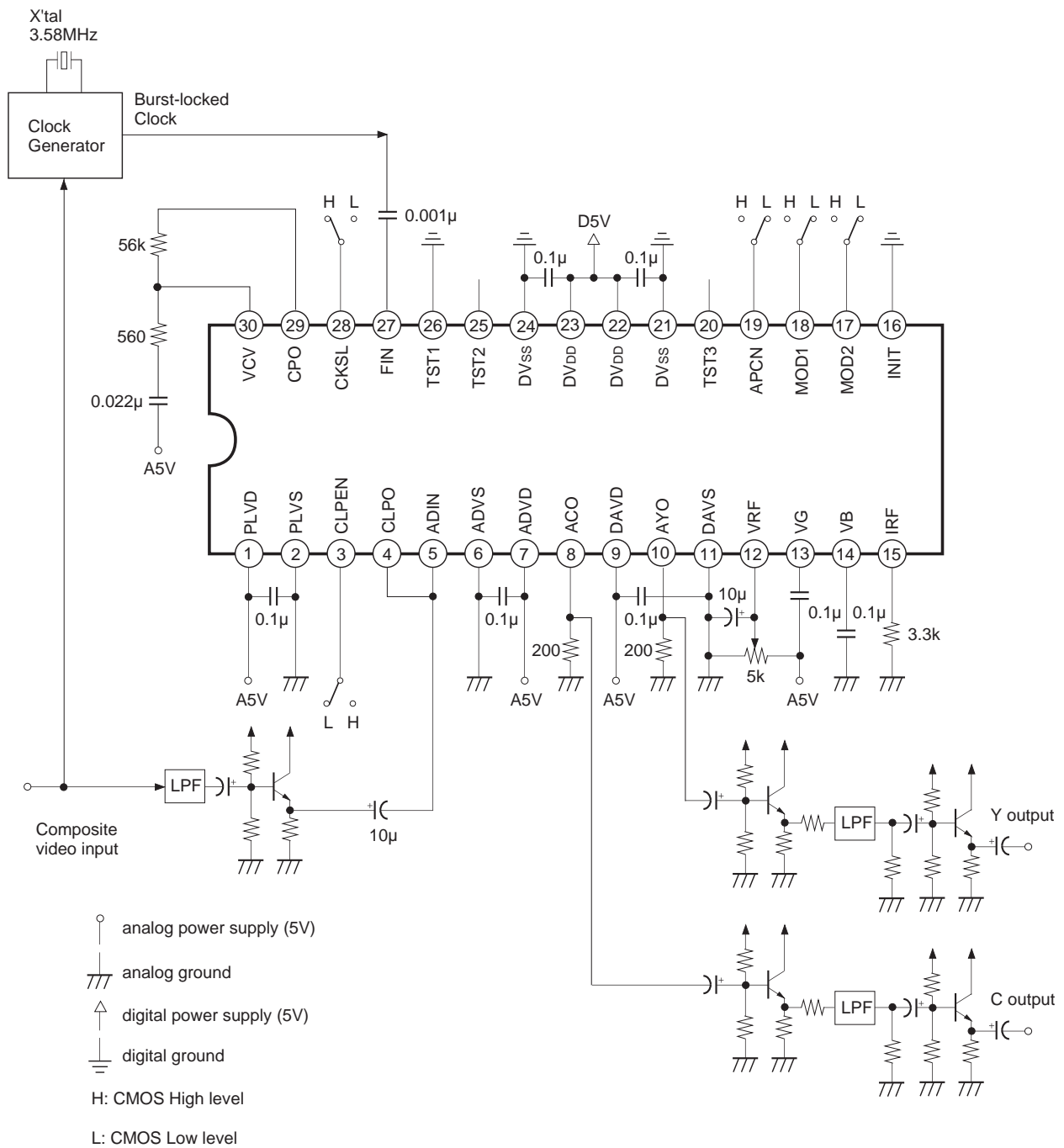

Application circuits shown are typical examples illustrating the operation of the devices. Sony cannot assume responsibility for any problems arising out of the use of these circuits or for any infringement of third party patent and other right due to same.

(2) When the 4fsc clock is used

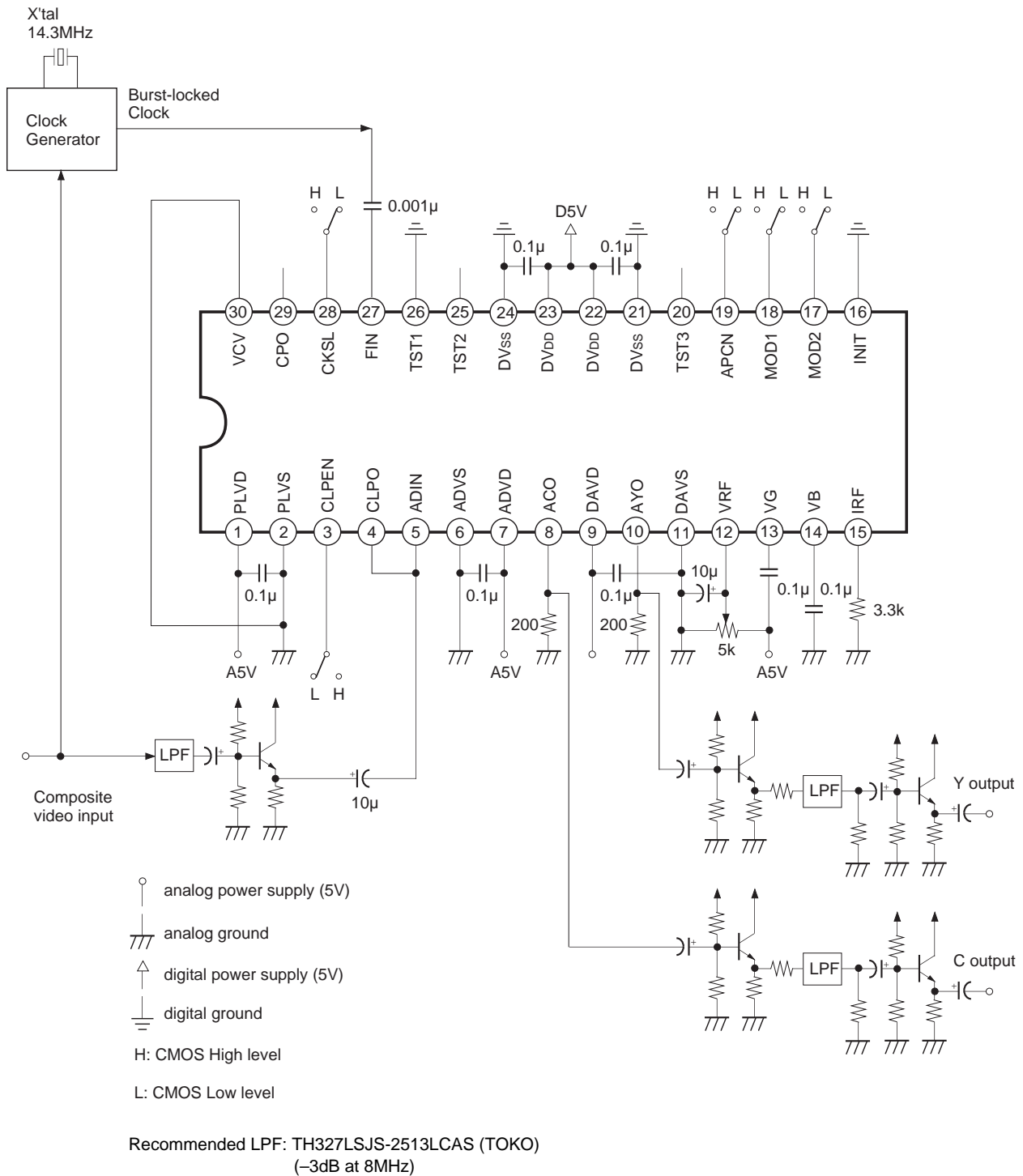

Application circuits shown are typical examples illustrating the operation of the devices. Sony cannot assume responsibility for any problems arising out of the use of these circuits or for any infringement of third party patent and other right due to same.

Example of Representative Characteristics

Analog I/O amplitude ratio vs. VRF pin voltage

Input signal peak-to-peak voltage  $\leq 1.75V$

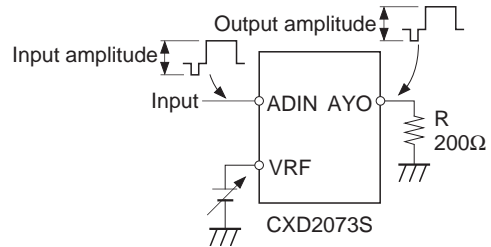
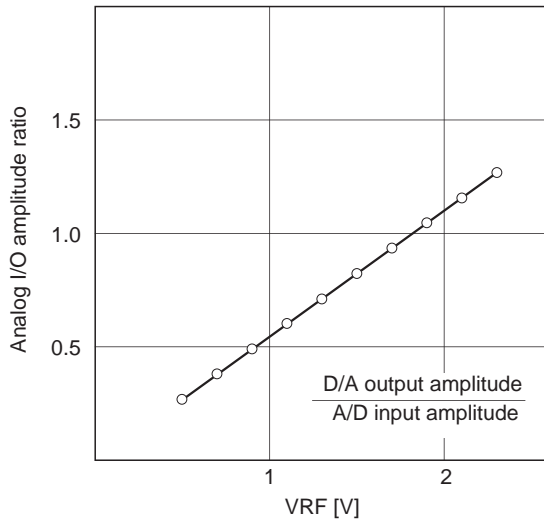

Output full-scale voltage vs. Ambient temperature

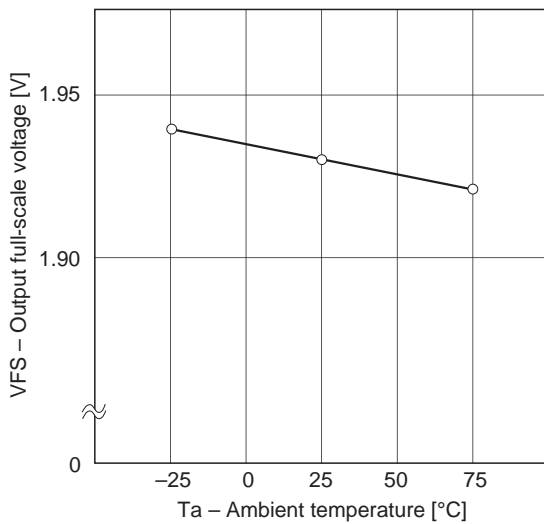

VDD = 5V  
 VRF = 2V  
 IRF = 3.3kΩ  
 R = 200Ω

AYO (Y output) frequency response

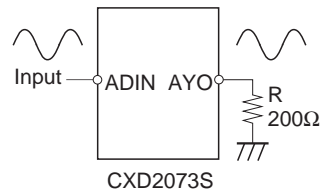
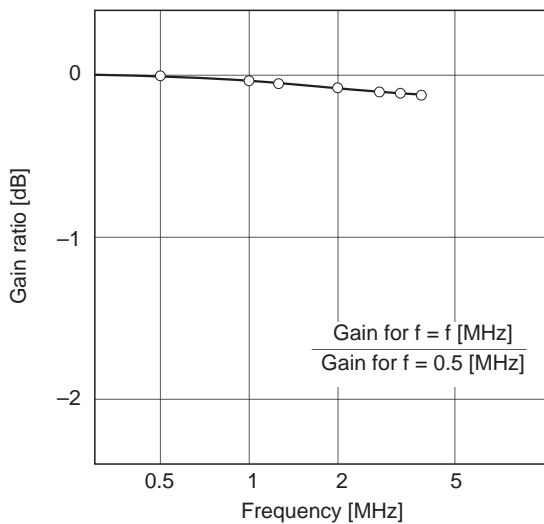

Package Outline

Unit: mm

30PIN SDIP (PLASTIC)

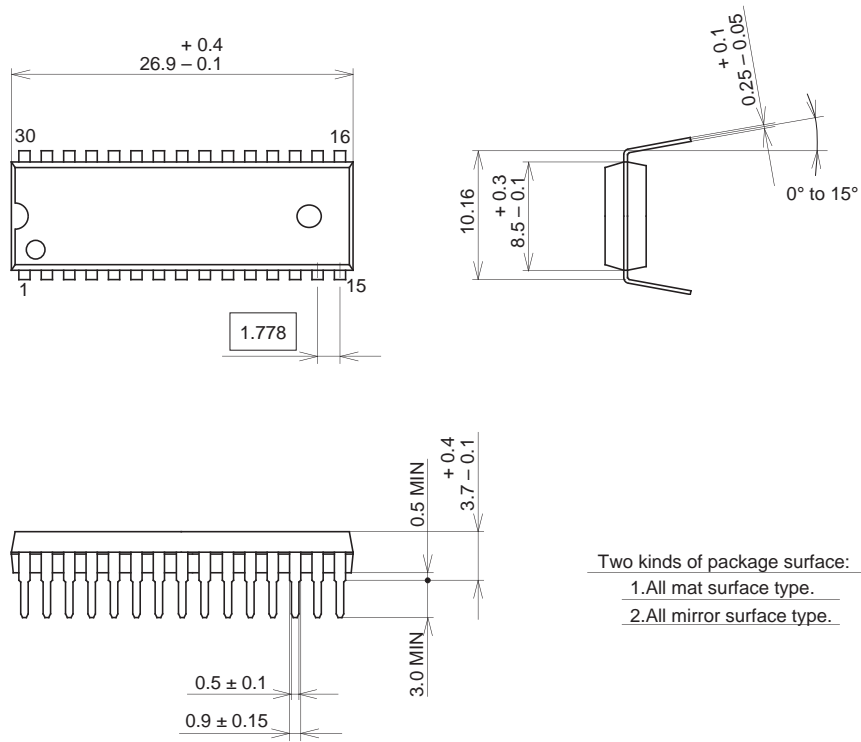

Two kinds of package surface:

- 1. All mat surface type.
- 2. All mirror surface type.

PACKAGE STRUCTURE

SONY CODE	SDIP-30P-01
EIAJ CODE	SDIP030-P-0400
JEDEC CODE	—

MOLDING COMPOUND	EPOXY RESIN
LEAD TREATMENT	SOLDER/PALLADIUM PLATING
LEAD MATERIAL	COPPER ALLOY
PACKAGE MASS	1.8g



LittleDiode supplies new, hard to find or obsolete electronic components and semiconductors all over the world.

With over two million different components listed you are sure to find the part you need.

Feel free to visit us today at our online store:

**[LittleDiode.com](http://LittleDiode.com)**

Looking forward to providing you with the best possible service.