

10-bit 50MSPS RGB 3-channel D/A Converter

Description

The CXD2307R is a 10-bit high-speed D/A converter for video band, featuring RGB 3-channel I/O. This is ideal for use in high-definition TVs and high-resolution displays.

Features

- Resolution 10-bit
- Maximum conversion speed 50MSPS
- RGB 3-channel I/O
- Differential linearity error $\pm 0.5\text{LSB}$
- Low power consumption; 300 mW (max.)
- Single +5 V power supply
- Low glitch
- Stand-by function

Structure

Silicon gate CMOS IC

64 pin LQFP (Plastic)

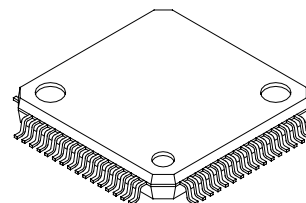

Absolute Maximum Ratings (Ta=25 °C)

- Supply voltage AV_{DD}, DV_{DD} 7 V
- Input voltage (All pins)
 V_{IN} $V_{DD}+0.5$ to $V_{SS}-0.5$ V
- Output current (for each channel)
 I_{OUT} 0 to 15 mA
- Storage temperature
 T_{stg} -55 to +150 °C

Recommended Operating Conditions

- Supply voltage AV_{DD}, AV_{SS} 4.75 to 5.25 V
 DV_{DD}, DV_{SS} 4.75 to 5.25 V
- Reference input voltage
 V_{REF} 1.8 to 2.0 V
- Clock pulse width
 T_{PW1}, T_{PW0} 9 ns (min.) to 1.1 μs (max.)
- Operating temperature
 T_{opr} -20 to +85 °C

Sony reserves the right to change products and specifications without prior notice. This information does not convey any license by any implication or otherwise under any patents or other right. Application circuits shown, if any, are typical examples illustrating the operation of the devices. Sony cannot assume responsibility for any problems arising out of the use of these circuits.

Block Diagram

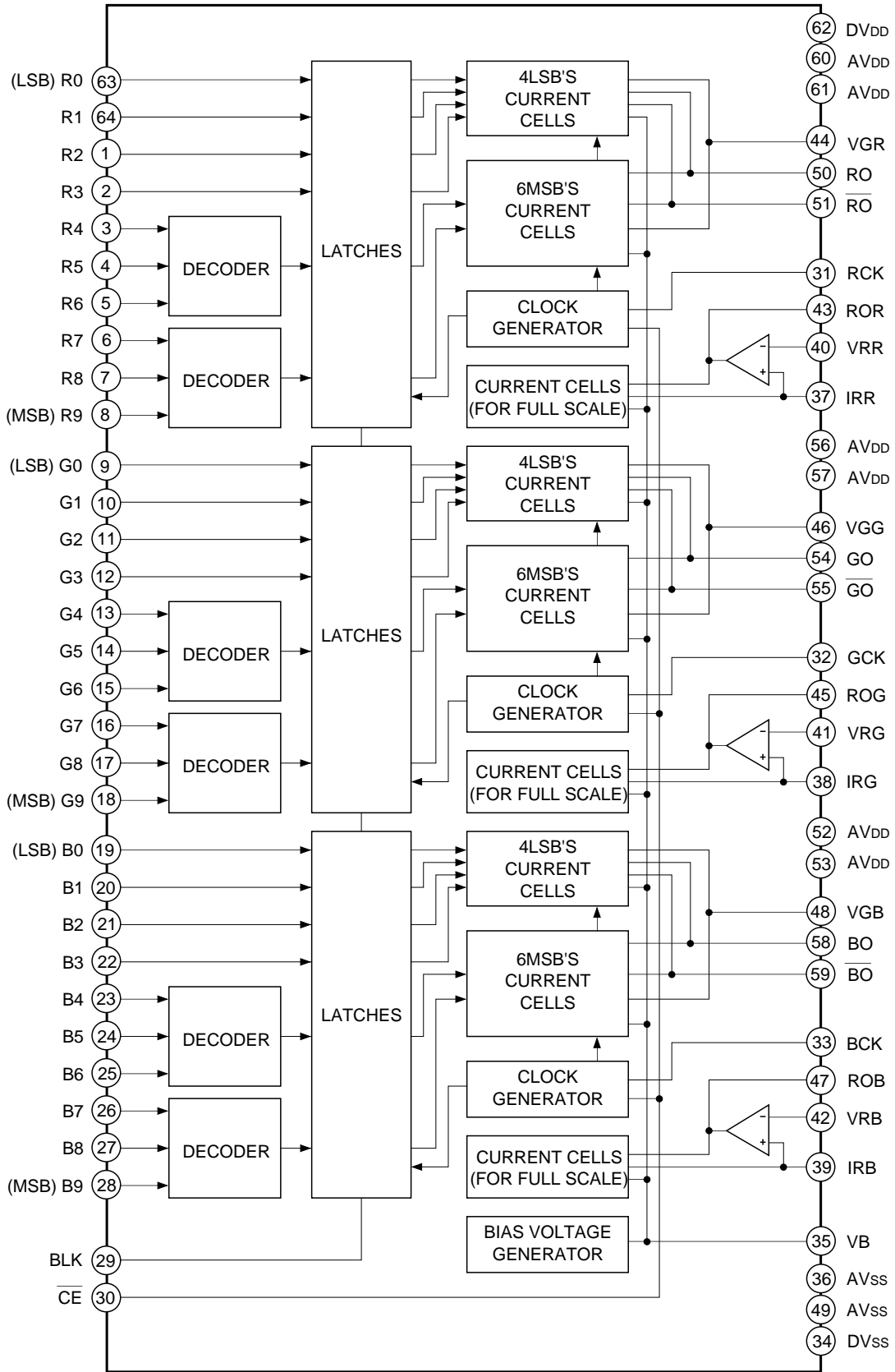

Pin Configuration

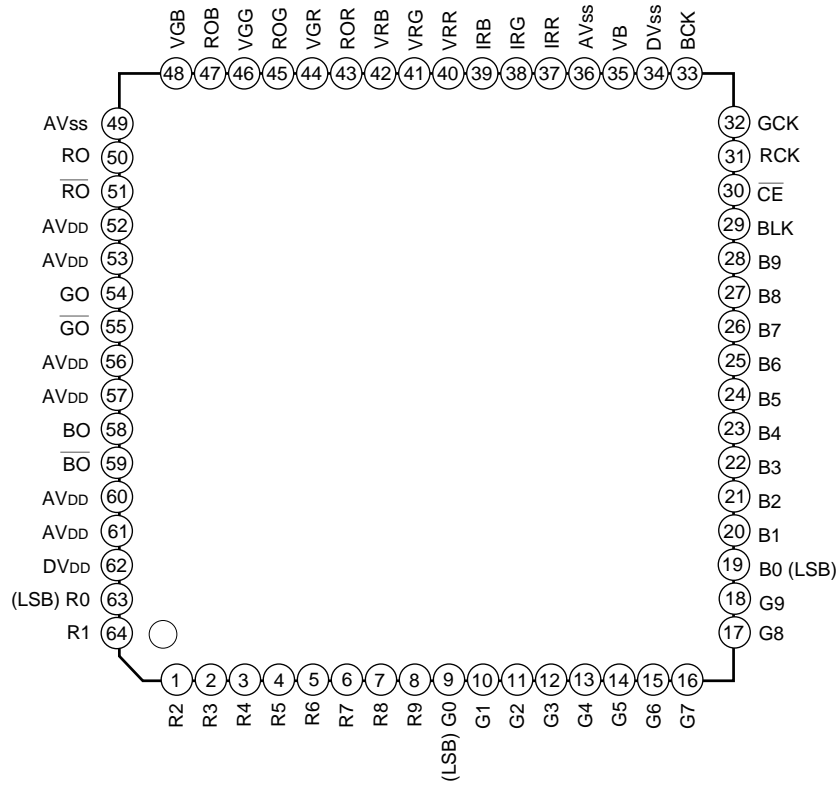

Pin Description and Equivalent Circuit

Pin No.	Symbol	I/O	Equivalent circuit	Description
63 to 8 9 to 18 19 to 28	R0 to R9 G0 to G9 B0 to B9			Digital input. R0 (LSB) to R9 (MSB) G0 (LSB) to G9 (MSB) B0 (LSB) to B9 (MSB)
29	BLK			Blanking input. This is synchronized with the clock input signal for each channel. No signal for High (0 V output). Output generated for Low.
30	CE	I		Chip enable pin. This is not synchronized with the clock input signal. No signal at for High (0 V output) to minimize power consumption.
31 32 33	RCK GCK BCK			Clock input.
34	DVss	—		Digital ground.

Pin No.	Symbol	I/O	Equivalent circuit	Description
35	VB	O		Connect to DVSS with a capacitor of approximately 0.1 μF.
36, 49	AVSS	—		Analog grounds.
43 45 47	ROR ROG ROB	O		Connect to VGR, VGG, and VGB with the control method of output amplitude. See Application Circuit.
44 46 48	VGR VGG VGB	I		Connect a capacitor of approximately 0.1 μF.
37 38 39	IRR IRG IRB	O		Connect to AVSS with a resistance of 3.3 kΩ .
40 41 42	VRR VRG VRB	I		Set output full-scale value (2.0 V).

Pin No.	Symbol	I/O	Equivalent circuit	Description
50	RO	O		Current output pins. Output can be retrieved by connecting a resistance of 200 Ω to AVss.
54	GO			
58	BO			
51	\overline{RO}			Reverse current output pins. Normally connected to AVss.
55	\overline{GO}			
59	\overline{BO}			
52, 53, 56, 57, 60, 61	AV _{DD}	—		Analog V _{DD} .
62	DV _{DD}	—		Digital V _{DD} .

Timing Chart

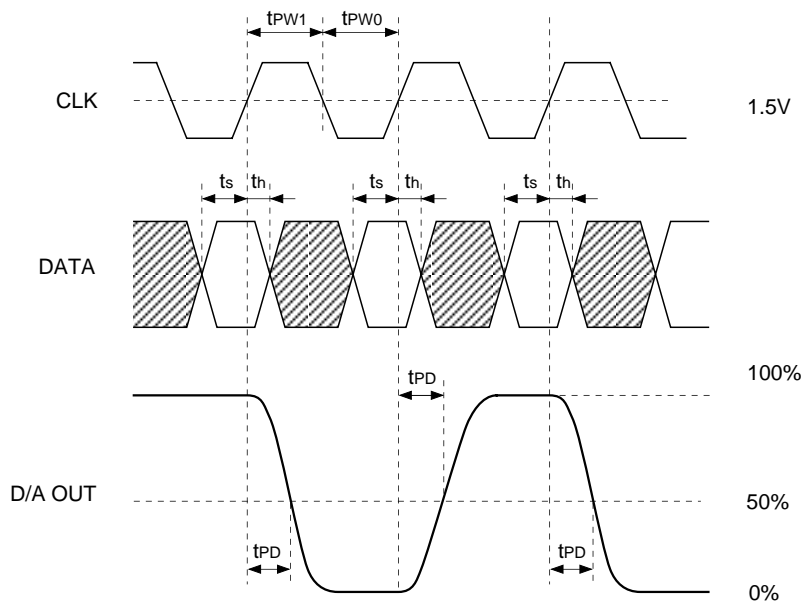

I/O Correspondence Table (output full-scale voltage: 2.00 V)

Input code		Output voltage
MSB	LSB	
1 1 1 1 1 1 1 1 1 1		2.0 V
	:	
1 0 0 0 0 0 0 0 0 0		1.0 V
	:	
0 0 0 0 0 0 0 0 0 0		0 V

Electrical Characteristics

(F_{CLK}=50 MHz, AV_{DD}=DV_{DD}=5 V, R_{OUT}=200 Ω, V_{REF}=2.0 V, Ta=25 °C)

Item	Symbol	Measurement conditions	Min.	Typ.	Max.	Unit
Resolution	n			10		bit
Conversion speed	F _{CLK}	AV _{DD} =DV _{DD} =4.75 to 5.25 V Ta=-20 to 85 °C	0.5		50	MSPS
Integral non-linearity error	EL	Endpoint	-2.0		2.0	LSB
Differential non-linearity error	ED		-0.5		0.5	LSB
Precision guaranteed output voltage range	V _{OC}		1.8	1.9	2.0	V
Output full-scale voltage	V _{FS}		1.8	1.9	2.0	V
Output full-scale ratio *1	F _{SR}	For the same gain (See the Application Circuit)	0	1.5	3.0	%
Output full-scale current	I _{FS}			9.5	10	mA
Output offset voltage	V _{OS}	When "0000000000" data input			1	mV
Glitch energy	GE			100		pV•s
Crosstalk	CT	When 10 MHz sine wave data input		54		dB
Supply current	I _{DD}	\overline{CE} = "L"		55	60	mA
	I _{STB}	\overline{CE} = "H"			1	
Analog input resistance	R _{IN}	V _{GR} , V _{GG} , V _{GB} , V _{RR} , V _{RG} , V _{RB}	1			MΩ
Input capacitance	C _I				9	pF
Output capacitance	C _O	RO,GO,BO		50		pF
Digital input voltage	V _{IH}	AV _{DD} =DV _{DD} =4.75 to 5.25 V Ta=-20 to +75 °C	2.15			V
	V _{IL}				0.85	
Digital input current	I _{IH}	AV _{DD} =DV _{DD} =4.75 to 5.25 V Ta=-20 to +75 °C	-5		5	μA
	I _{IL}					
Setup time	t _s		7			ns
Hold time	t _h		3			ns
Propagation delay time	t _{PD}			10		ns
CE enable time *2	t _E	\overline{CE} = H→L		1	2	ms
CE disable time *2	t _D	\overline{CE} = L→H		1	2	ms

*1 Full-scale output ratio = $\left| \frac{\text{Full-scale voltage for each channel}}{\text{Full-scale voltage average value for each channel}} - 1 \right| \times 100 (\%)$

*2 When the external capacitors for the VG pins are 0.1 μF.

Electrical Characteristics Measurement Circuit

Analog Input Resistance
Digital Input Current

Measurement Circuit

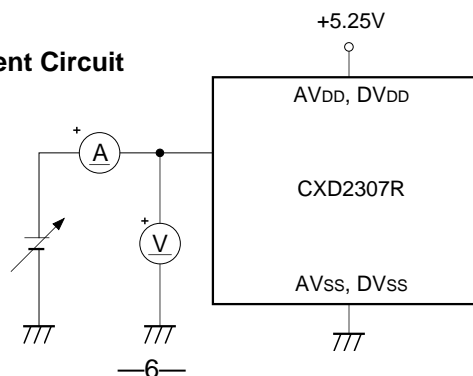

Maximum Conversion Speed Measurement Circuit

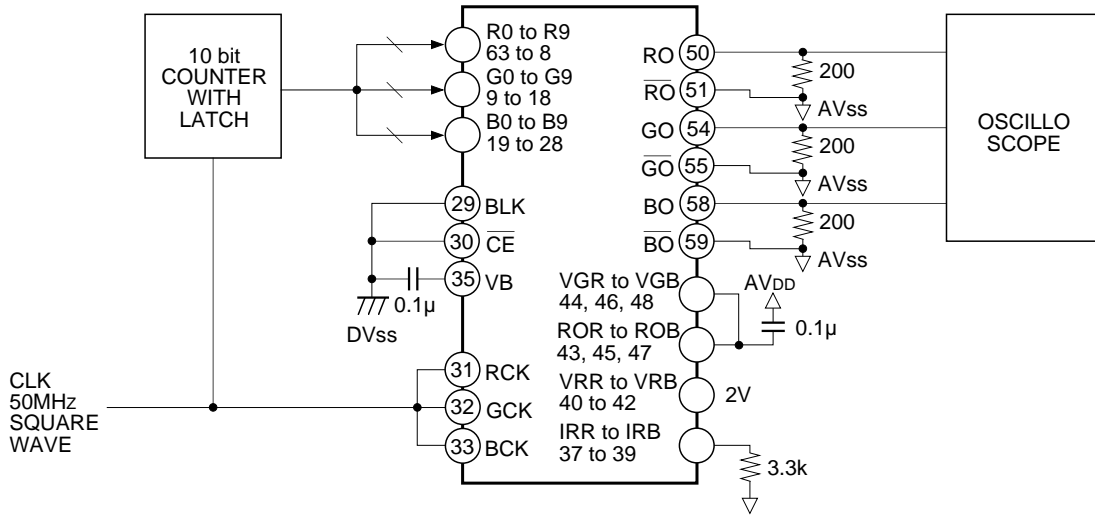

Setup Time
Hold Time
Glitch Energy

Measurement Circuit

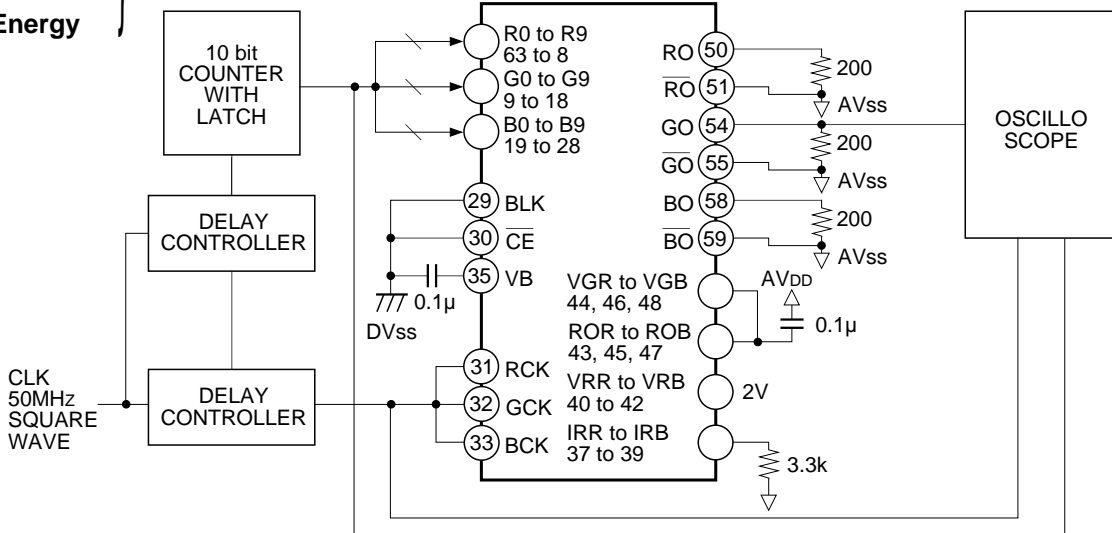

Cross Talk Measurement Circuit

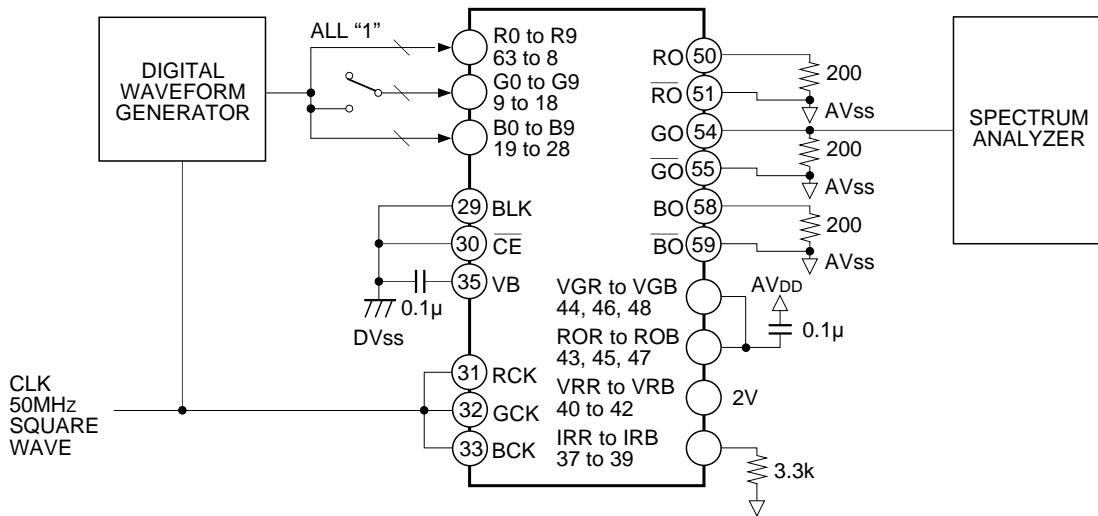

DC Characteristics Measurement Circuit

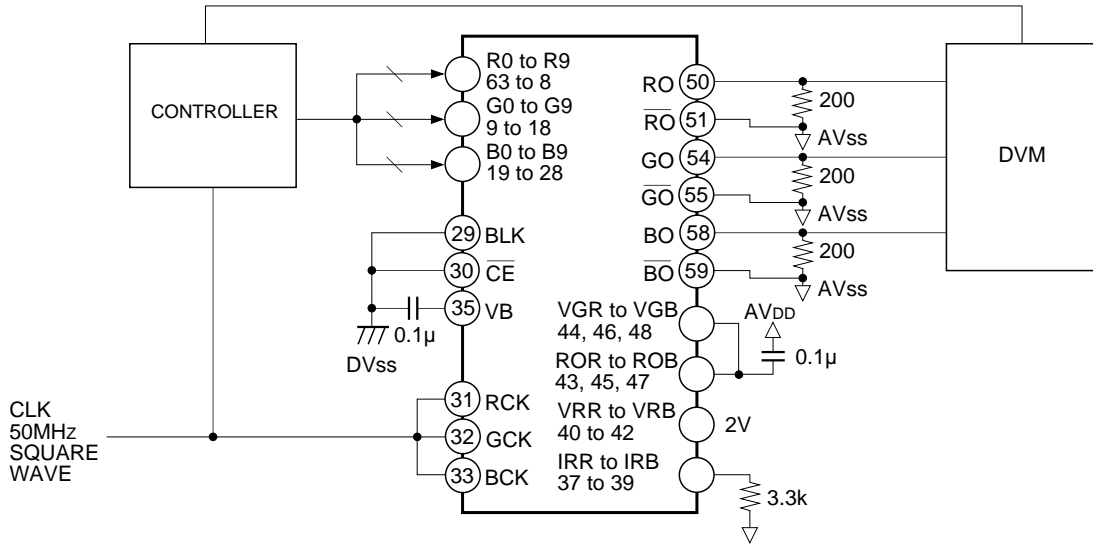

Propagation Delay Time Measurement Circuit

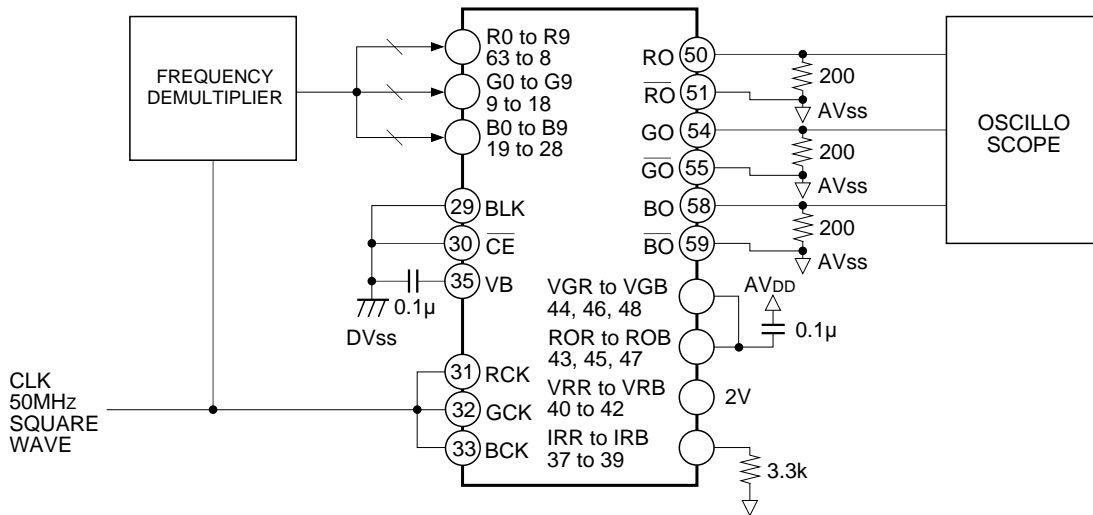

Application Circuit

(Gain equal)

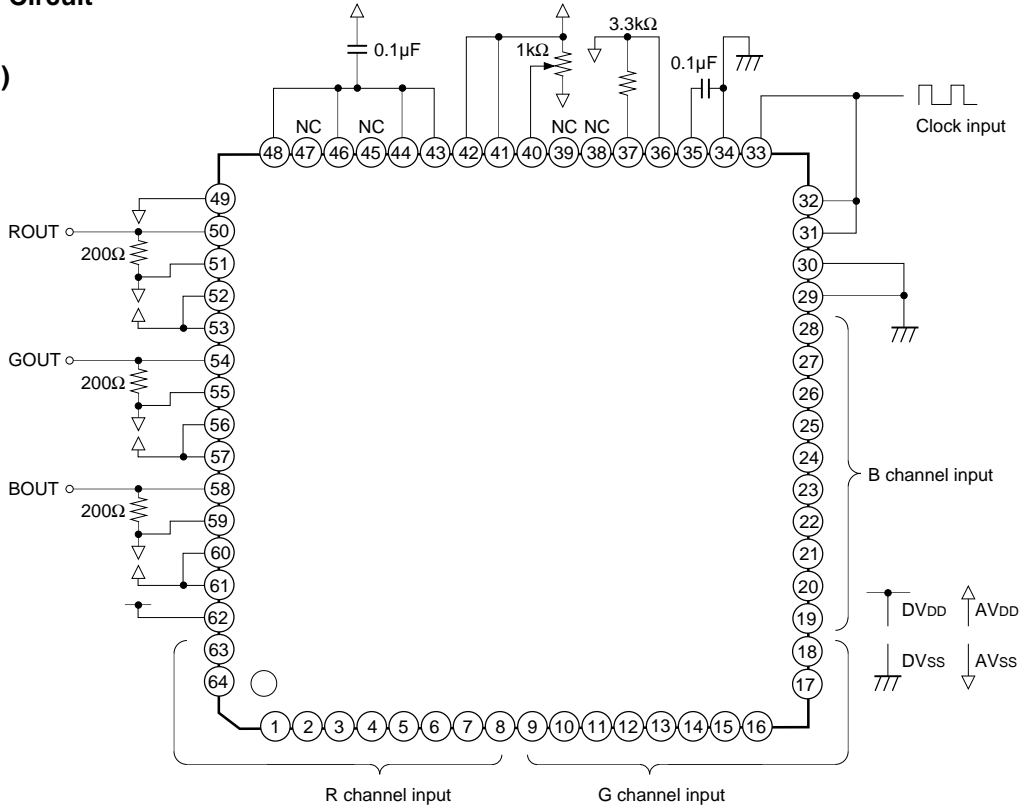

(Gain independently)

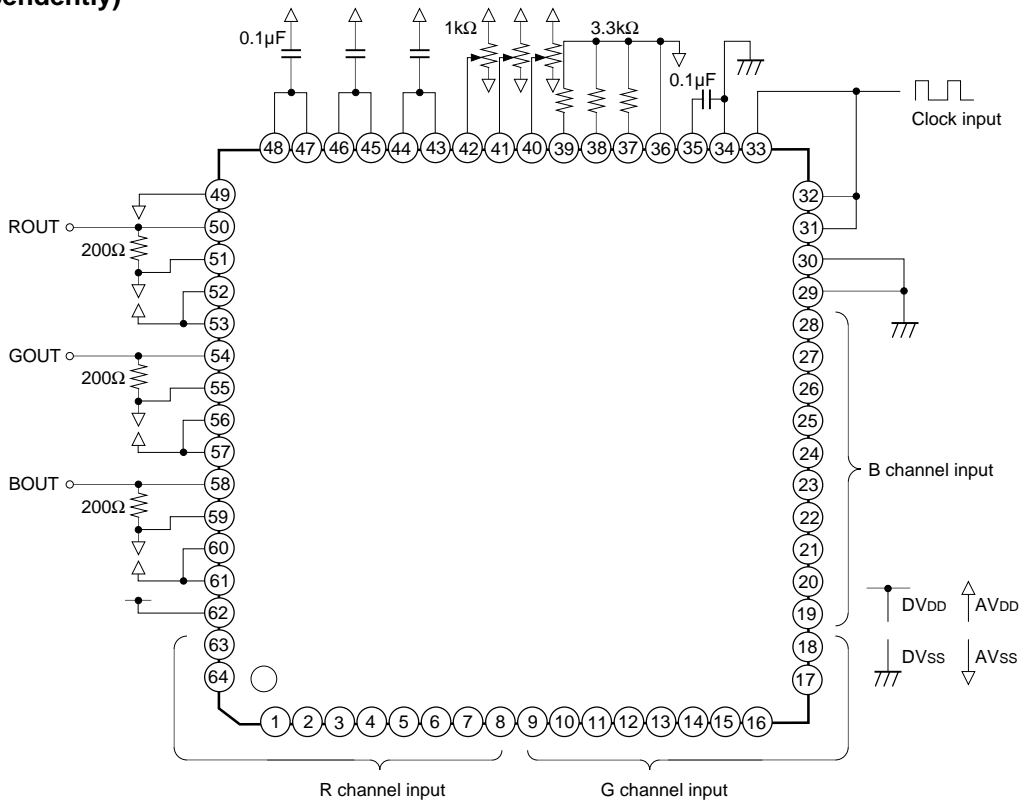

Application circuits shown are typical examples illustrating the operation of the devices. Sony cannot assume responsibility for any problems arising out of the use of these circuits or for any infringement of third party patent and other right due to same.

Notes on Operation

- How to select the output resistance

The CXD2307R is a D/A converter of the current output type. To obtain the output voltage connect the resistance to the current output pins \overline{RO} , \overline{GO} and \overline{BO} . For specifications we have:

Output full scale voltage $V_{FS}=1.8$ to 2.0 [V]

Output full scale current $I_{FS}=\text{less than } 15$ [mA]

Calculate the output resistance value from the relation of $V_{FS}=I_{FS} \times R_{OUT}$. Also, 16 times resistance of the output resistance is connected to reference current pin IRR, IRG and IRB. In some cases, however, this turns out to be a value that does not actually exist. In such a case a value close to it can be used as a substitute.

Here please note that V_{FS} becomes $V_{FS}=V_{REF} \times 16R_{OUT}/R_{IR}$. V_{REF} is the voltage set at V_{RR} , V_{RG} and the VRB pin, and R_{OUT} is the resistance connected to the current output pins \overline{RO} , \overline{GO} and \overline{BO} while R_{IR} is connected to IRR, IRG and IRB. Increasing the resistance value can curb power consumption. On the other hand glitch energy and data settling time will inversely increase. Set the most suitable value according to the desired application.

- Phase relation between data and clock

To obtain the expected performance as a D/A converter, it is necessary to set properly the phase relation between data and clock applied from the exterior. Be sure to satisfy the provisions of the setup time (t_s) and hold time (t_H) as stipulated in the Electrical Characteristics.

- Power supply and ground

To reduce noise effects separate analog and digital systems in the device periphery. For power supply pins, both digital and analog, bypass respective grounds by using a ceramic capacitor of about $0.1 \mu\text{F}$, as close as possible to the pin.

- Latch up

Analog power supply and digital power supply have to be common at the PCB power supply source. This is to prevent latch up due to voltage difference between AV_{DD} and DV_{DD} pins when power supply is turned ON.

- \overline{RO} , \overline{GO} and \overline{BO} pins

The \overline{RO} , \overline{GO} and \overline{BO} pins are the inverted current output pins described in the Pin Description. The sums shown below become the constant value for any input data.

a) The sum of the currents output from \overline{RO} and \overline{RO}

b) The sum of the currents output from \overline{GO} and \overline{GO}

c) The sum of the currents output from \overline{BO} and \overline{BO}

However, the performances such as the linearity error of the inverted current output pin output current is not guaranteed.

- Output full-scale voltage

For the applications using the RGB signal, the color balance may be broken up when the no-adjusted output full-scale voltage is used.

Latch Up Prevention

The CXD2307R is a CMOS IC which requires latch up precautions. Latch up is mainly generated by the lag in the voltage rising time of AV_{DD} and DV_{DD}, when power supply is ON.

1. Correct usage

a. When analog and digital supplies are from different sources

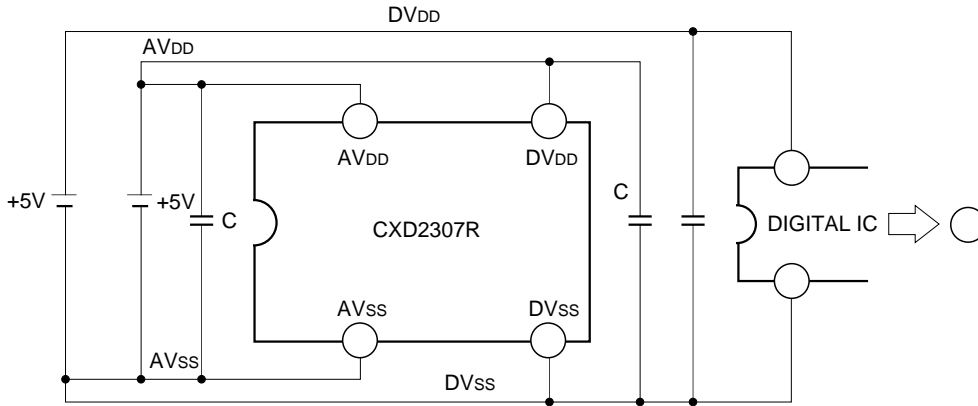

b. When analog and digital supplies are from a common source

(i)

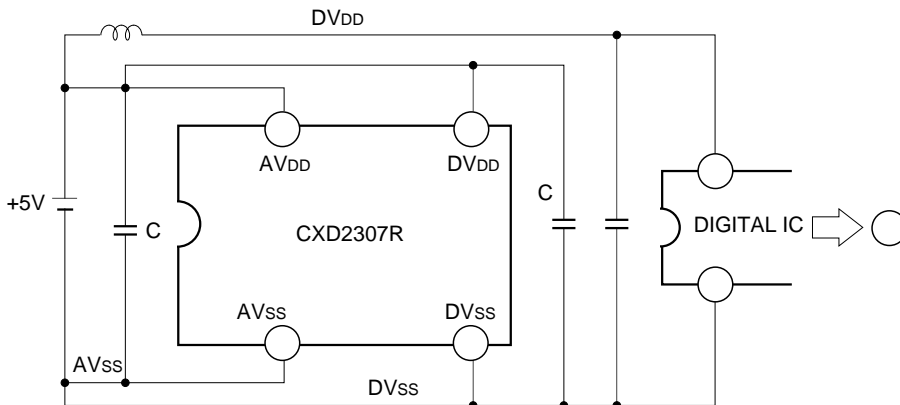

(ii)

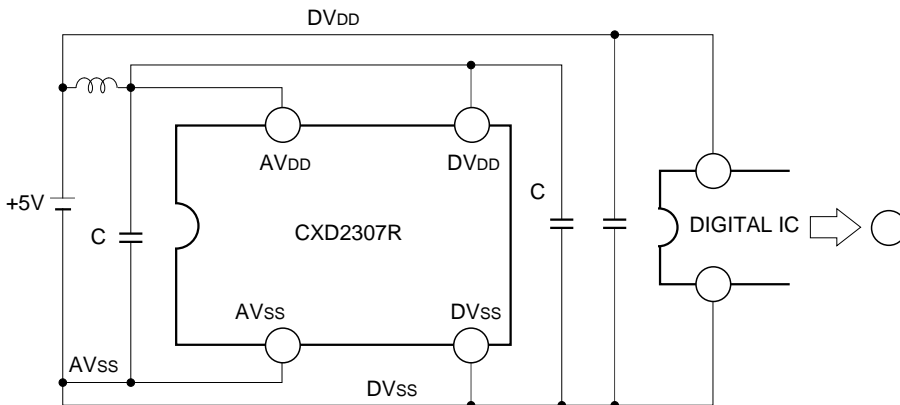

2. Example when latch up easily occurs

a. When analog and digital supplies are from different sources

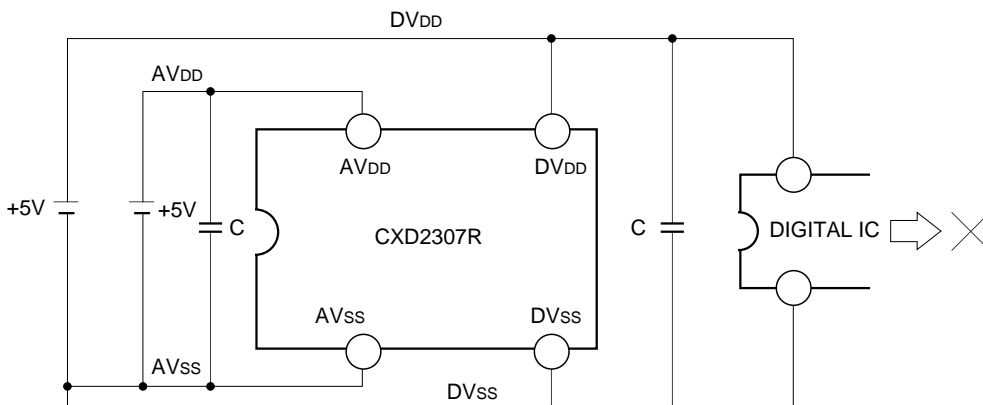

b. When analog and digital supplies are from common source

(i)

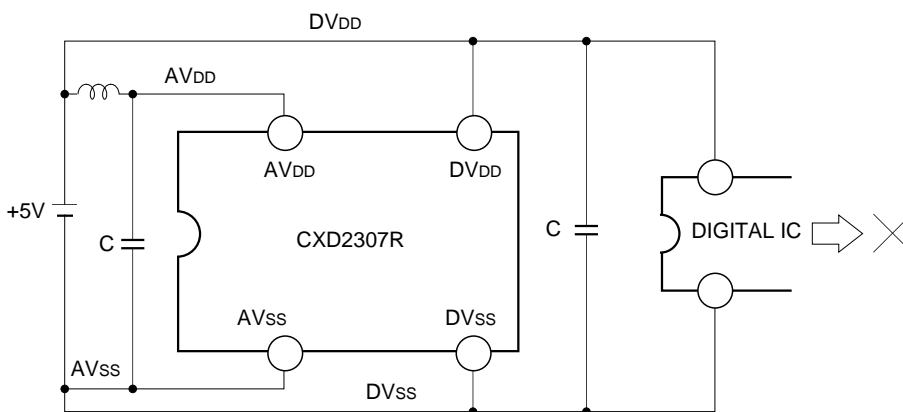

(ii)

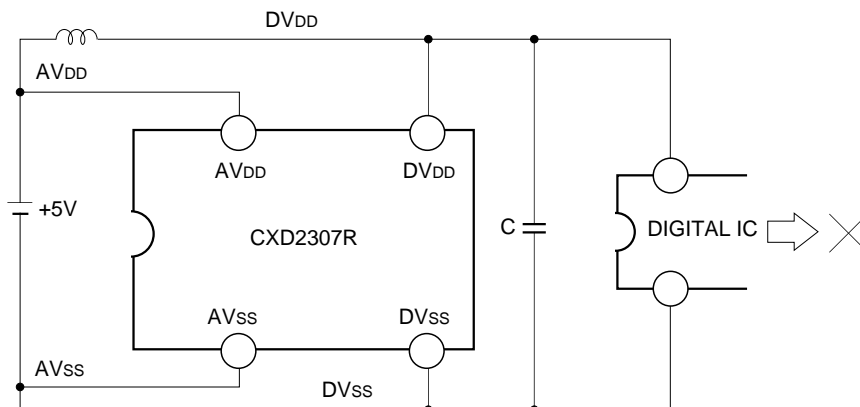

Example of Representative Characteristics

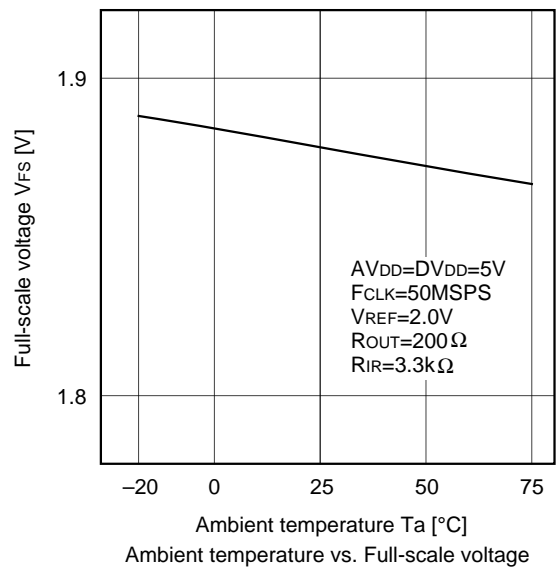
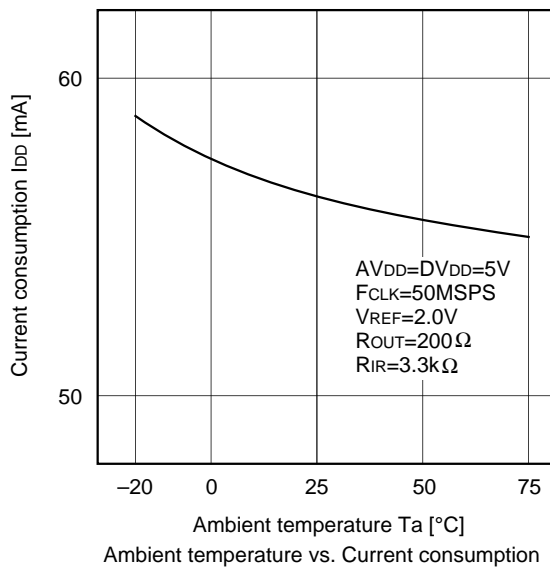
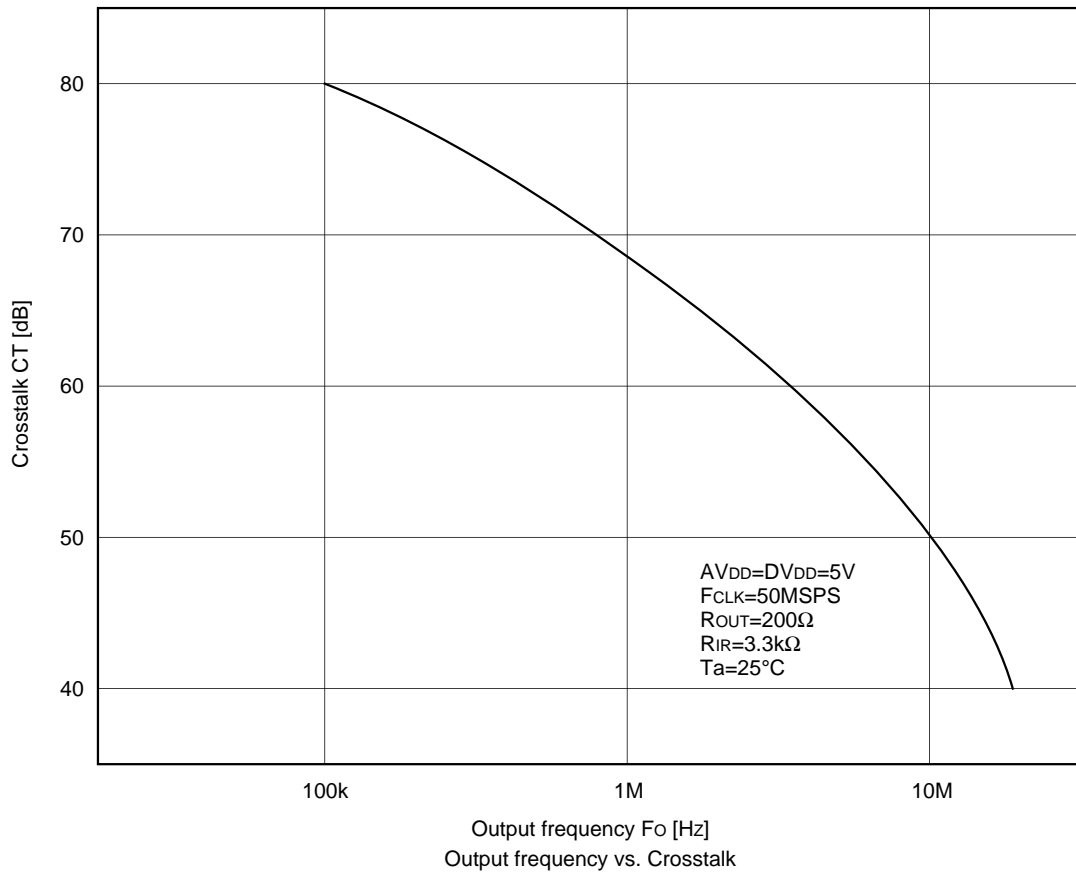

Package Outline Unit : mm

64PIN LQFP (PLASTIC)

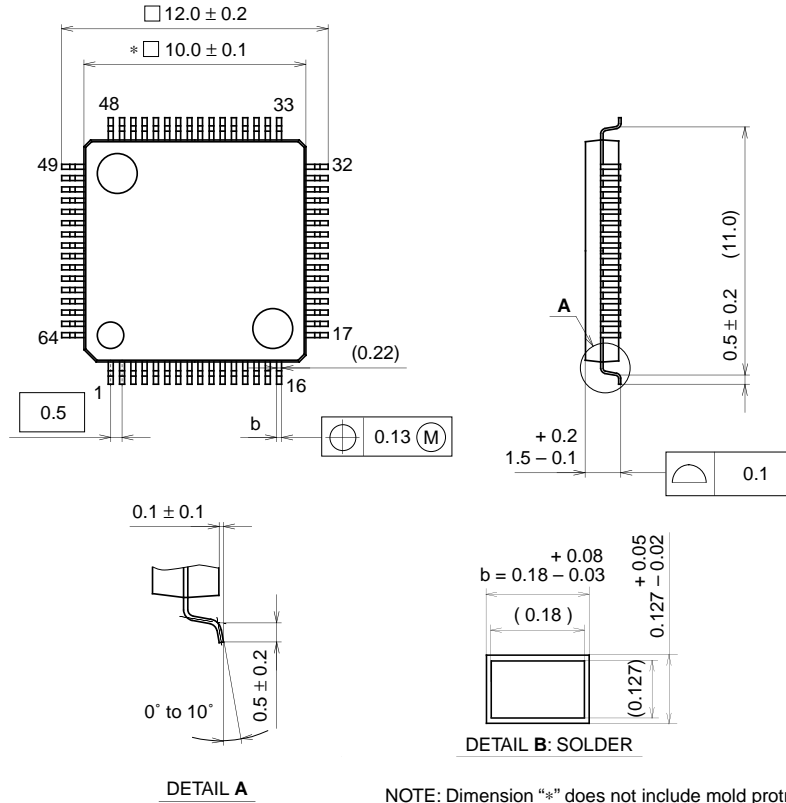

NOTE: Dimension "*" does not include mold protrusion.

PACKAGE STRUCTURE

SONY CODE	LQFP-64P-L01
EIAJ CODE	P-LQFP64-10x10-0.5
JEDEC CODE	_____

PACKAGE MATERIAL	EPOXY RESIN
LEAD TREATMENT	SOLDER PLATING
LEAD MATERIAL	42/COPPER ALLOY
PACKAGE MASS	0.3g

Package Outline Unit : mm

64PIN LQFP (PLASTIC)

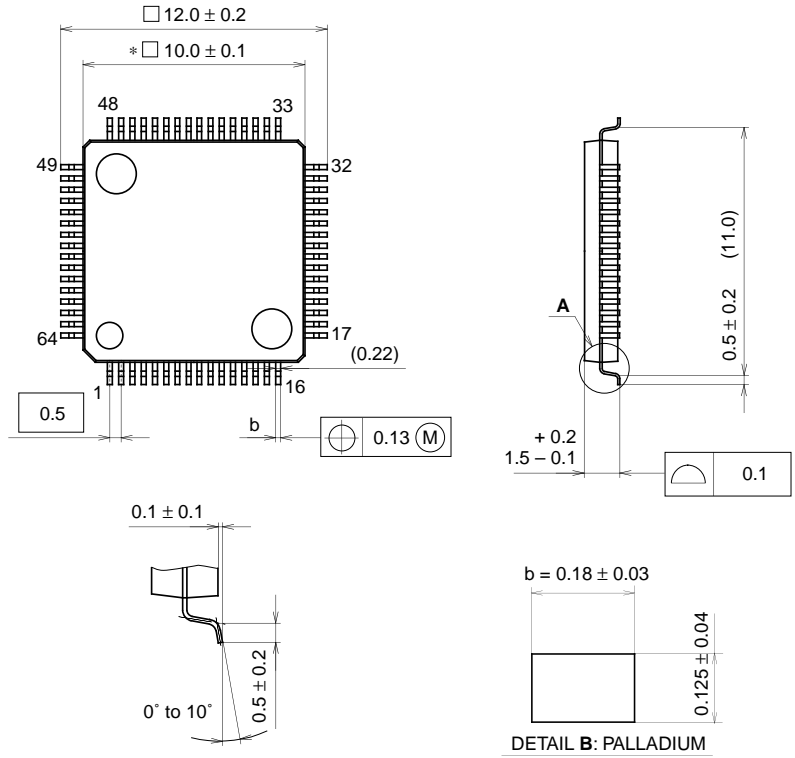

DETAIL A

DETAIL B: PALLADIUM

NOTE: Dimension "*" does not include mold protrusion.

PACKAGE STRUCTURE

SONY CODE	LQFP-64P-L01
EIAJ CODE	P-LQFP64-10x10-0.5
JEDEC CODE	_____

PACKAGE MATERIAL	EPOXY RESIN
LEAD TREATMENT	PALLADIUM PLATING
LEAD MATERIAL	COPPER ALLOY
PACKAGE MASS	0.3g



LittleDiode supplies new, hard to find or obsolete electronic components and semiconductors all over the world.

With over two million different components listed you are sure to find the part you need.

Feel free to visit us today at our online store:

LittleDiode.com

Looking forward to providing you with the best possible service.