

CD Digital Signal Processor with Built-in Digital Servo and DAC

**Description**

The CXD2548R is a digital signal processor LSI for CD players. This LSI incorporates a digital servo, digital filter, zero detection circuit, 1-bit DAC and analog low-pass filter on a single chip.

**Features**

- All digital signal processing during playback is performed with a single chip
- Highly integrated mounting possible due to a built-in RAM

**Digital Signal Processor (DSP) Block**

- Playback mode which supports CAV (Constant Angular Velocity)
  - Frame jitter free
  - 0.5 × to 2.5 × continuous playback possible
  - Allows relative rotational velocity readout
  - Supports spindle external control
- Wide capture range playback mode
  - Spindle rotational velocity following method
  - Supports normal-speed, double-speed playback
- 16K RAM
- EFM data demodulation
- Enhanced EFM frame sync signal protection
- SEC strategy-based error correction
- Subcode demodulation and Sub Q data error detection
- Digital spindle servo
  - 16-bit traverse counter
  - Asymmetry compensation circuit
  - CPU interface on serial bus
  - Error correction monitor signal, etc. output from a new CPU interface
- Servo auto sequencer
- Digital audio interface outputs
- Digital level meter, peak meter

**Digital Servo (DSSP) Block**

- Microcomputer software-based flexible servo control
- Offset cancel function for servo error signal
- Auto gain control function for servo loop
- E:F balance, focus bias adjustment functions
- Surf jump function supporting micro two-axis

**Digital Filter, DAC and Analog Low-Pass Filter Blocks**

- Digital de-emphasis
- Digital attenuation
- Zero detection function
- 8Fs oversampling digital filter
- S/N: 100dB or more (master clock: 384Fs, typ.)
- THD + N: 0.007% or more (master clock: 384Fs, typ.)
- Rejection band attenuation: -60dB or more

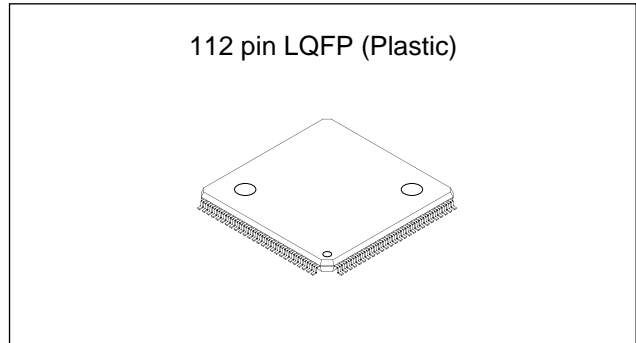

**Applications**

CD players

**Structure**

Silicon gate CMOS IC

**Absolute Maximum Ratings**

- Supply voltage  $V_{DD}$  -0.3 to +7.0 V
- Input voltage  $V_I$  -0.3 to +7.0 V
- Output voltage  $V_O$  -0.3 to +7.0 V
- Storage temperature  $T_{stg}$  -40 to +125 °C
- Supply voltage difference
  - $V_{SS} - AV_{SS}$  -0.3 to +0.3 V
  - $V_{DD} - AV_{DD}$  -0.3 to +0.3 V

**Recommended Operating Conditions**

- Supply voltage  $V_{DD}^{Note}$  -3.4 to +5.25 V
- Operating temperature  $T_{opr}$  -20 to +75 °C

**Note)** The  $V_{DD}$  (Min.) for the CXD2548R varies according to the playback speed selection.

Playback speed	$V_{DD}$ (min.) [V]		
	CD-DSP block	DAC block	DSSP block
2 ×	3.4V	4.5V	3.4V
1 ×	3.4V	3.4V	3.4V
1 ×*1	3.4V	/	3.4V

\*1 When the internal operation of the CD-DSP side is set to double-speed mode and the crystal oscillation frequency is halved, normal-speed playback results.

**I/O Capacitance**

- Input pin  $C_i$  12 (Max.) pF
- Output pin  $C_o$  12 (Max.) pF

**Note)** Measurement conditions  $V_{DD} = V_I = 0V$   
 $f_m = 1MHz$

Sony reserves the right to change products and specifications without prior notice. This information does not convey any license by any implication or otherwise under any patents or other right. Application circuits shown, if any, are typical examples illustrating the operation of the devices. Sony cannot assume responsibility for any problems arising out of the use of these circuits.

Block Diagram

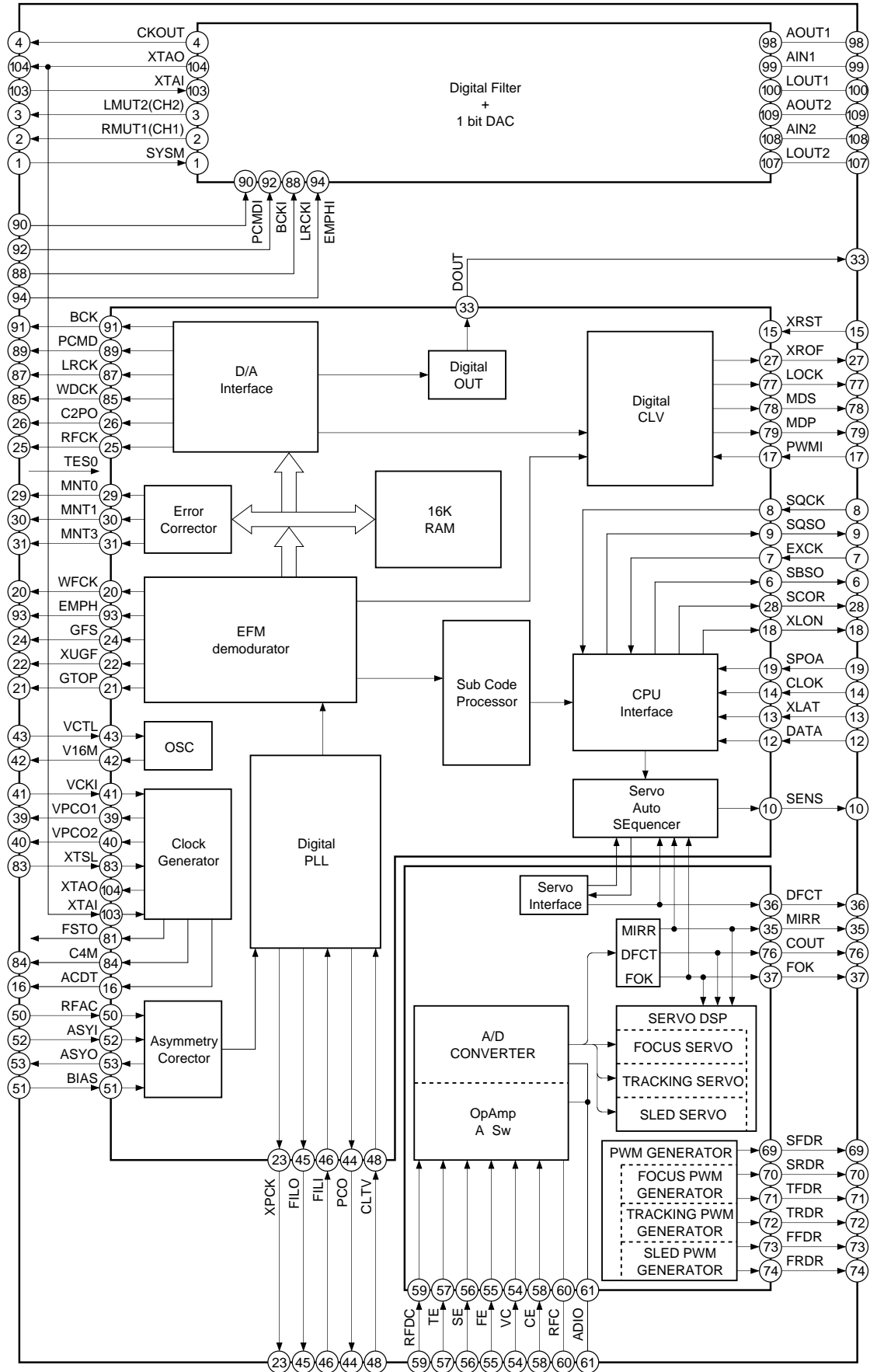

Pin Configuration

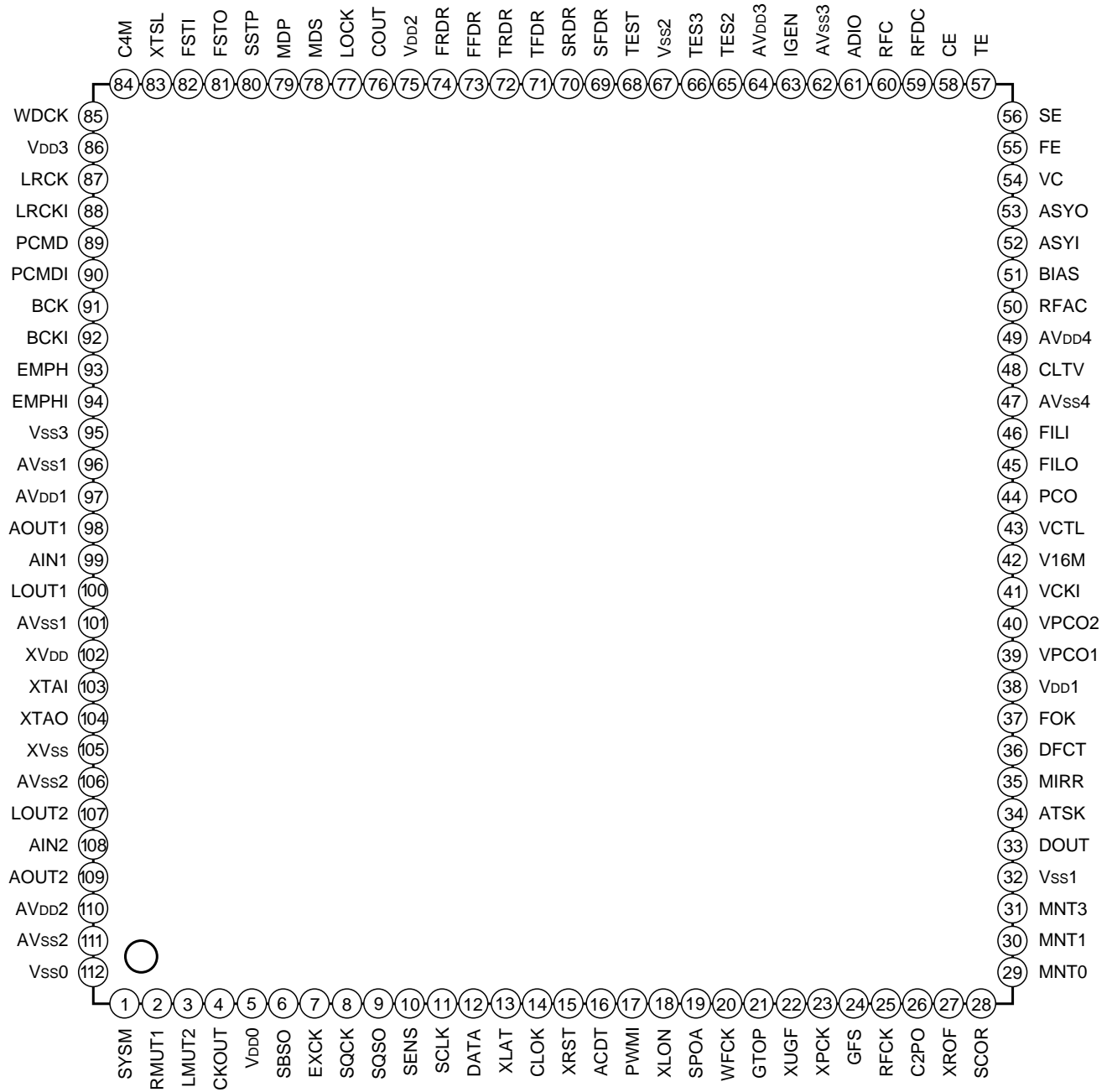

## Pin Description

Pin No.	Symbol	I/O		Description
1	SYSM	I		System mute input. (high = on, low = off)
2	RMUT1	O	1, 0	R ch zero detection output. (high = on, low = off)
3	LMUT2	O	1, 0	L ch zero detection output. (high = on, low = off)
4	CKOUT	O	1, 0	DAC master clock frequency division output. Either the clock input from $XTAI \times 1$ , $\times 1/2$ or $\times 1/4$ , or low output is selected and output.
5	V <sub>DD0</sub>			Digital power supply.
6	SBSO	O	1, 0	Sub P to W serial output.
7	EXCK	I		SBSO readout clock input.
8	SQCK	I		SQSO readout clock input.
9	SQSO	O	1, 0	Sub Q 80-bit and PCM peak and level data 16-bit output.
10	SENS	O	1, 0	SENS output to CPU.
11	SCLK	I		SENS serial data readout clock input.
12	DATA	I		Serial data input from CPU.
13	XLAT	I		Latch input from CPU. Serial data is latched at the falling edge.
14	CLOK	I		Serial data transfer clock input from CPU.
15	XRST	I		System reset. Reset when low.
16	ACDT	O	1, 0	Normally not used. Leave open.
17	PWMI	I		Spindle motor external control input.
18	XLON	O	1, 0	Microcomputer extension interface (output).
19	SPOA	I		Microcomputer extension interface (input A).
20	WFCK	O	1, 0	WFCK (Write Flame Clock) output.
21	GTOP	O	1, 0	GTOP output.
22	XUGF	O	1, 0	XUGF output.
23	XPCK	O	1, 0	XPLCK output.
24	GFS	O	1, 0	GFS output.
25	RFCK	O	1, 0	RFCK output.
26	C2PO	O	1, 0	C2PO output.
27	XROF	O	1, 0	XRAOF output.
28	SCOR	O	1, 0	Outputs a high signal when either subcode sync S0 or S1 is detected.
29	MNT0	O	1, 0	MNT0 output.
30	MNT1	O	1, 0	MNT1 output.
31	MNT3	O	1, 0	MNT3 output.
32	V <sub>SS1</sub>			Digital GND.
33	DOUT	O	1, 0	Digital Out output pin.
34	ATSK	I		Anti-shock pin.
35	MIRR	O	1, 0	Mirror signal output.
36	DFCT	O	1, 0	Defect signal output.

Pin No.	Symbol	I/O		Description
37	FOK	O	1, 0	Focus OK signal output.
38	V <sub>DD1</sub>			Digital power supply.
39	VPCO1	O	1, Z, 0	Wide-band EFM PLL charge pump output.
40	VPCO2	O	1, Z, 0	Wide-band EFM PLL VCO2 charge pump output.
41	VCKI	I		Wide-band EFM PLL VCO2 oscillation input.
42	V16M	O	1, 0	Wide-band EFM PLL VCO2 oscillation output.
43	VCTL	I		Wide-band EFM PLL VCO2 control input.
44	PCO	O	1, Z, 0	Master PLL charge pump output.
45	FILO	O	Analog	Master PLL filter output (slave = digital PLL).
46	FILI	I		Master PLL filter input.
47	AV <sub>ss4</sub>			Analog GND.
48	CLTV	I		Master VCO control voltage input.
49	AV <sub>DD4</sub>			Analog power supply.
50	RFAC	I		EFM signal input.
51	BIAS	I		Asymmetry circuit constant current input.
52	ASYI	I		Asymmetry comparator voltage input.
53	ASYO	O	1, 0	EFM full-swing output (low = V <sub>ss</sub> , high = V <sub>DD</sub> ).
54	VC	I		Center voltage input.
55	FE	I		Focus error signal input.
56	SE	I		Sled error signal input.
57	TE	I		Tracking error signal input.
58	CE	I		Center error signal input.
59	RFDC	I		RF signal input. Input range: 2.15 to 5.0V. (when DV <sub>DD</sub> = AV <sub>DD</sub> = 5.0V)
60	RFC	I		Connects an RF signal LPF time-constant capacitor.
61	ADIO	O		Operational amplifier output.
62	AV <sub>ss3</sub>			Analog GND.
63	IGEN	I		Connects an operational amplifier current source reference resistor.
64	AV <sub>DD3</sub>			Analog power supply.
65	TES2	I		Test pin. Normally fixed to low.
66	TES3	I		Test pin. Normally fixed to low.
67	V <sub>ss2</sub>			Digital GND.
68	TEST	I		Test pin. Normally fixed to low.
69	SFDR	O	1, 0	Sled drive output.
70	SRDR	O	1, 0	Sled drive output.
71	TFDR	O	1, 0	Tracking drive output.
72	TRDR	O	1, 0	Tracking drive output.
73	FFDR	O	1, 0	Focus drive output.

Pin No.	Symbol	I/O		Description
74	FRDR	O	1, 0	Focus drive output.
75	V <sub>DD2</sub>			Digital power supply.
76	COUT	O	1, 0	Track count signal output.
77	LOCK	O	1, 0	GFS is sampled at 460Hz; when GFS is high, this pin outputs a high signal. If GFS is low eight consecutive samples, this pin outputs low.
78	MDS	O	1, 0	Spindle motor servo control output.
79	MDP	O	1, 0	Spindle motor servo control output.
80	SSTP	I		Disc innermost track detection signal input.
81	FSTO	O	1, 0	2/3-frequency division output for Pins 103 and 104.
82	FSTI	I		Digital servo reference clock input.
83	XTSL	I		Crystal selection input. Low when the crystal is 16.9344MHz; high when the crystal is 33.8688MHz.
84	C4M	O	1, 0	4.2336MHz output.
85	WDCK	O	1, 0	D/A interface. Word clock $f = 2F_s$
86	V <sub>DD3</sub>			Digital power supply.
87	LRCK	O	1, 0	D/A interface. LR clock $f = F_s$
88	LRCKI	I		LR clock input to DAC (48-bit slot).
89	PCMD	O	1, 0	D/A interface. Serial data. (two's complement, MSB first)
90	PCMDI	I		Audio data input to DAC (48-bit slot).
91	BCK	O	1, 0	D/A interface. Bit clock.
92	BCKI	I		Bit clock input to DAC (48-bit slot).
93	EMPH	O	1, 0	Outputs a high signal when the playback disc has emphasis, and a low signal when there is no emphasis.
94	EMPHI	I		DAC de-emphasis ON/OFF. (high = on, low = off)
95	V <sub>SS3</sub>			Digital GND.
96	AV <sub>SS1</sub>			L ch, analog GND.
97	AV <sub>DD1</sub>			L ch, analog power supply.
98	AOUT1	O	Analog	L ch, analog output.
99	AIN1	I		L ch, operational amplifier input.
100	LOUT1	O	Analog	L ch, LINE output.
101	AV <sub>SS1</sub>			L ch, analog GND.
102	XV <sub>DD</sub>			Master clock analog power supply.
103	XTAI	I		Master clock 16.9344MHz crystal oscillation circuit input, or 33.8688MHz input.
104	XTAO	O	1, 0	Master clock 16.9344MHz crystal oscillation circuit output.
105	XV <sub>SS</sub>			Master clock analog GND.
106	AV <sub>SS2</sub>			R ch, analog GND.
107	LOUT2	O	Analog	R ch, LINE output.
108	AIN2	I		R ch, operational amplifier input.
109	AOUT2	O	Analog	R ch, analog output.

Pin No.	Symbol	I/O		Description
110	AV <sub>DD2</sub>			R ch, analog power supply.
111	AV <sub>SS2</sub>			R ch, analog GND.
112	V <sub>SS0</sub>			Digital GND.

- Notes)**
- PCMD is a MSB first, two's complement output.
  - GTOP is used to monitor the frame sync protection status. (High: sync protection window released.)
  - XUGF is the frame sync obtained from the EFM signal, and negative pulse. It is the signal before sync protection.
  - XPLCK is the inverse of the EFM PLL clock. The PLL is designed so that the falling edge and the EFM signal transition point coincide.
  - The GFS signal goes high when the frame sync and the insertion timing match.
  - RFCK is derived from the crystal accuracy, and has a cycle of 136 $\mu$ s (during normal speed).
  - C2PO represents the data error status.
  - XRAOF is generated when the 16K RAM exceeds the  $\pm 4F$  jitter margin.

## Electrical Characteristics

## 1. DC Characteristics

(V<sub>DD</sub> = AV<sub>DD</sub> = 5.0V ± 5%, V<sub>SS</sub> = AV<sub>SS</sub> = 0V, Topr = -20 to +75°C)

Item			Conditions	Min.	Typ.	Max.	Unit	Applicable pins
Input voltage (1)	High level input voltage	V <sub>IH</sub> (1)		0.7V <sub>DD</sub>			V	*1
	Low level input voltage	V <sub>IL</sub> (1)				0.3V <sub>DD</sub>	V	
Input voltage (2)	High level input voltage	V <sub>IH</sub> (2)	Schmitt input	0.8V <sub>DD</sub>			V	*2
	Low level input voltage	V <sub>IL</sub> (2)				0.2V <sub>DD</sub>	V	
Input voltage (3)	Input voltage	V <sub>IN</sub> (3)	Analog input	V <sub>SS</sub>		V <sub>DD</sub>	V	*3, 7, 8, 10
Output voltage (1)	High level output voltage	V <sub>OH</sub> (1)	I <sub>OH</sub> = -4mA	V <sub>DD</sub> - 0.8		V <sub>DD</sub>	V	*4
	Low level output voltage	V <sub>OL</sub> (1)	I <sub>OL</sub> = 4mA	0		0.4	V	
Output voltage (2)	High level output voltage	V <sub>OH</sub> (2)	I <sub>OH</sub> = -2mA	V <sub>DD</sub> - 0.8		V <sub>DD</sub>	V	*5
	Low level output voltage	V <sub>OL</sub> (2)	I <sub>OL</sub> = 4mA	0		0.4	V	
Output voltage (3)	High level output voltage	V <sub>OH</sub> (3)	I <sub>OH</sub> = -0.28mA	V <sub>DD</sub> - 0.5		V <sub>DD</sub>	V	*6
	Low level output voltage	V <sub>OL</sub> (3)	I <sub>OL</sub> = 0.36mA	0		0.4	V	
Input leak current (1)		I <sub>LI</sub> (1)	V <sub>I</sub> = 0 to 5.5V	-10		10	μA	*1, 2
Input leak current (2)		I <sub>LI</sub> (2)	V <sub>I</sub> = 1.5 to 3.5V	-20		20	μA	*7
Input leak current (3)		I <sub>LI</sub> (3)	V <sub>I</sub> = 0 to 5.0V	-40		600	μA	*8
Tri-state pin output leak current		I <sub>LO</sub>	V <sub>O</sub> = 0 to 5.5V	-5		5	μA	*9

## Applicable pins

\*1 XTSL, DATA, XLAT, TEST, TES2, TES3, SSTP, ATSK, PWMI, SYSM, EMPHI, PCMDI

\*2 CLOK, XRST, EXCK, SQCK, VCKI, LRCKI, BCKI, SPOA, SCLK

\*3 CLTV, FILI, RFAC, VCTL, AIN1, AIN2, ASYI

\*4 MDP, PCO, PDO, VPCO1, VPCO2

\*5 ASYO, DOUT, FSTO, C4M, SBSO, SQSO, SCOR, EMPH, LOCK, WDCK, SENS, MDS, MNT0, MNT1, MNT3, WFCK, V16M, CKOUT, LMUT2, RMUT1, XLON, LRCK, PCMD, BCK, GTOP, XUGF, XPCK, GFS, RFCK, C2PO, XRAOF, MIRR, DFCT, COUT, FFDR, FRDR, TFDR, TRDR, SFDR, SRDR

\*6 FILO

\*7 TE, SE, FE, CE, VC

\*8 RFDC

\*9 SENS, MDS, MDP, PDO, PCO, VPCO1, VPCO2

\*10 RFC

2. AC Characteristics

(1) XTAI pin

(a) When using self-excited oscillation

( $T_{opr} = -20$  to  $+75^{\circ}\text{C}$ ,  $V_{DD} = AV_{DD} = 5.0\text{V} \pm 5\%$ )

Item	Symbol	Min.	Typ.	Max.	Unit
Oscillation frequency	$f_{MAX}$	7		34	MHz

(b) When inputting pulses to XTAI pin

( $T_{opr} = -20$  to  $+75^{\circ}\text{C}$ ,  $V_{DD} = AV_{DD} = 5.0\text{V} \pm 5\%$ )

Item	Symbol	Min.	Typ.	Max.	Unit
High level pulse width	$t_{WHX}$	13		500	ns
Low level pulse width	$t_{WLX}$	13		500	ns
Pulse cycle	$t_{CK}$	26		1,000	ns
Input high level	$V_{IHx}$	$V_{DD} - 1.0$			V
Input low level	$V_{ILx}$			0.8	V
Rise time, fall time	$t_R, t_F$			10	ns

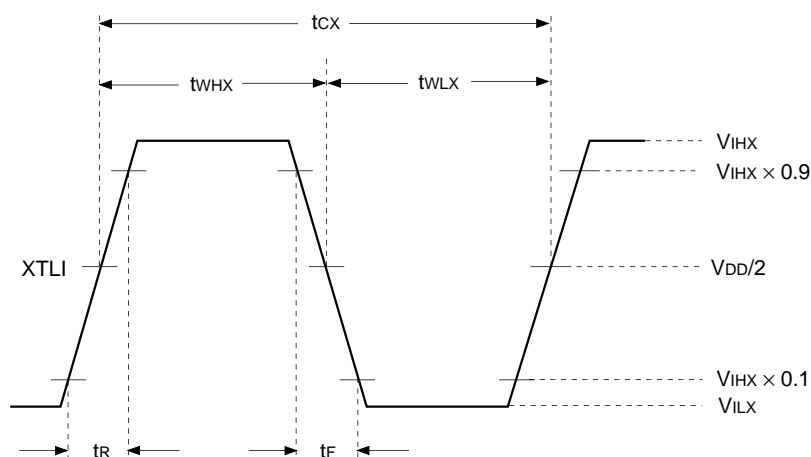

(c) When inputting sine waves to XTLI pin via a capacitor

( $T_{opr} = -20$  to  $+75^{\circ}\text{C}$ ,  $V_{DD} = AV_{DD} = 5.0\text{V} \pm 5\%$ )

Item	Symbol	Min.	Typ.	Max.	Unit
Input amplitude	$V_i$	2.0		$V_{DD} + 0.3$	Vp-p

(2) CLOK, DATA, XLAT, SQCK, and EXCK pins

( $V_{DD} = AV_{DD} = 5.0V \pm 5\%$ ,  $V_{SS} = AV_{SS} = 0V$ ,  $T_{opr} = -20$  to  $+75^{\circ}C$ )

Item	Symbol	Min.	Typ.	Max.	Unit
Clock frequency	$f_{CK}$			0.65	MHz
Clock pulse width	$t_{WCK}$	750			ns
Setup time	$t_{SU}$	300			ns
Hold time	$t_H$	300			ns
Delay time	$t_D$	300			ns
Latch pulse width	$t_{WL}$	750			ns
EXCK, SQCK frequency	$f_T$			0.65*1	MHz
EXCK, SQCK pulse width	$f_{WT}$	750*1			ns

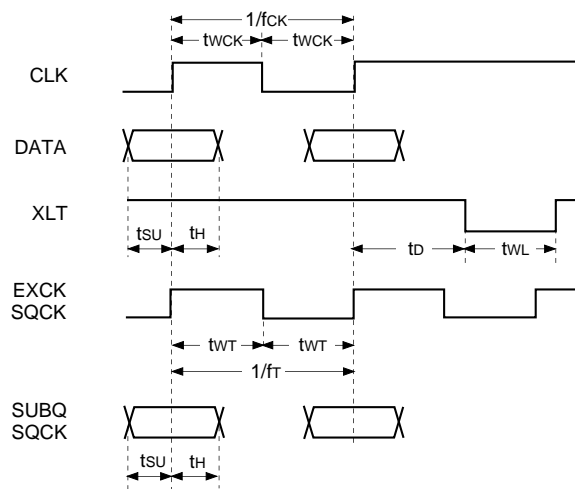

\*1 In quasi double-speed playback mode, except when SQSO is Sub Q Read, the SQCL maximum operating frequency is 300kHz and its minimum pulse width is 1.5 $\mu$ s.

(3) BCKI, LRCKI and PCMDI pins ( $V_{DD} = AV_{DD} = 5.0V \pm 5\%$ ,  $V_{SS} = AV_{SS} = 0V$ ,  $T_{opr} = -20$  to  $+75^{\circ}C$ )

Item	Symbol	Conditions	Min.	Typ.	Max.	Unit
BCK pulse width	$t_w$		94			ns
DATAL, R setup time	$t_{SU}$		18			ns
DATAL, R hold time	$t_H$		18			ns
LRCK setup time	$t_{SU}$		18			ns

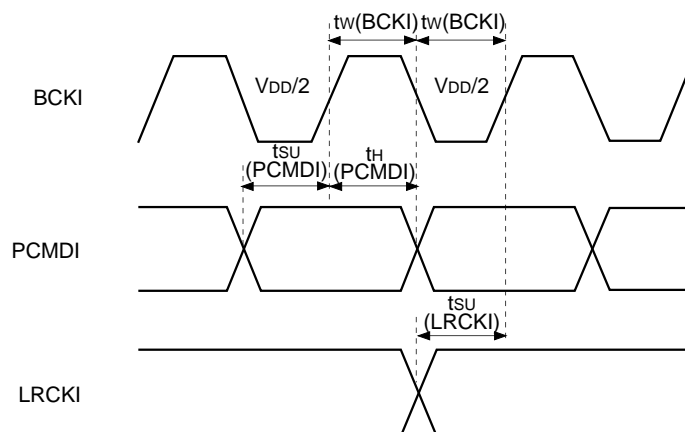

(4) SCLK pin

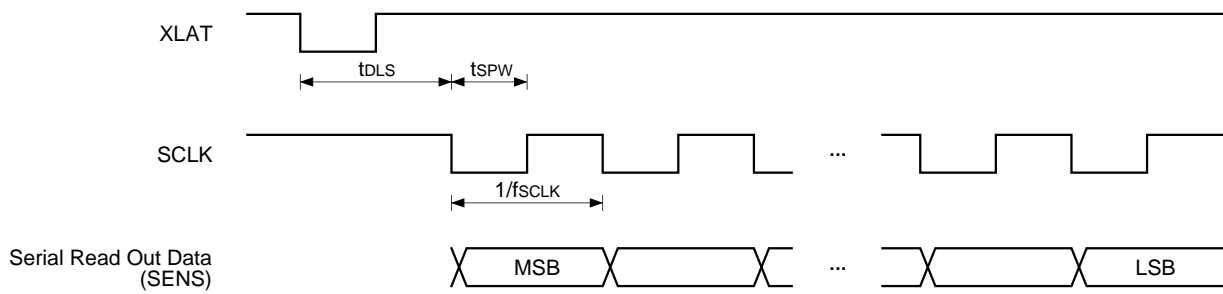

Item	Symbol	Min.	Typ.	Max.	Unit
SCLK frequency	$f_{SCLK}$			1	MHz
SCLK pulse width	$t_{SPW}$	500			ns
Delay time	$t_{DLS}$	15			$\mu$ s

(5) COUT, MIRR and DFCT pins

Operating frequency ( $V_{DD} = AV_{DD} = 5.0V \pm 5\%$ ,  $V_{SS} = AV_{SS} = 0V$ ,  $T_{opr} = -20$  to  $+75^{\circ}C$ )

Item	Symbol	Min.	Typ.	Max.	Unit	Conditions
COUT maximum operating frequency	$f_{COUT}$	40			kHz	*1
MIRR maximum operating frequency	$f_{MIRR}$	40			kHz	*2
DFCT maximum operating frequency	$f_{DFCTH}$	5			kHz	*3

\*1 When using a high-speed traverse TZC

\*2

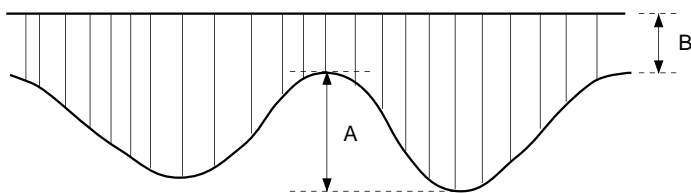

When the RF signal continuously satisfies the following conditions during the above traverse.

•  $A = 0.6$  to  $1.3V$

•  $\frac{B}{A + B} = 25\%$  or less

\*3 During complete RF signal omission

When settings related to DFCT signal generation are Typ.

**1-bit DAC and LPF Block Analog Characteristics**

Analog characteristics ( $V_{DD} = AV_{DD} = 5.0V$ ,  $V_{SS} = AV_{SS} = 0V$ ,  $T_a = 25^{\circ}C$ )

Item	Symbol	Conditions	Crystal	Min.	Typ.	Max.	Unit
Total harmonic distortion	THD	1kHz, 0dB data	384Fs		0.0050	0.0070	%
			768Fs		0.0045	0.0065	
Signal-to-noise ratio	S/N	1kHz, 0dB data (Using A-weighting filter)	384Fs	96	100		dB
			768Fs	96	100		

Fs = 44.1kHz in all cases.

The total harmonic distortion and signal-to-noise ratio measurement circuits are shown below.

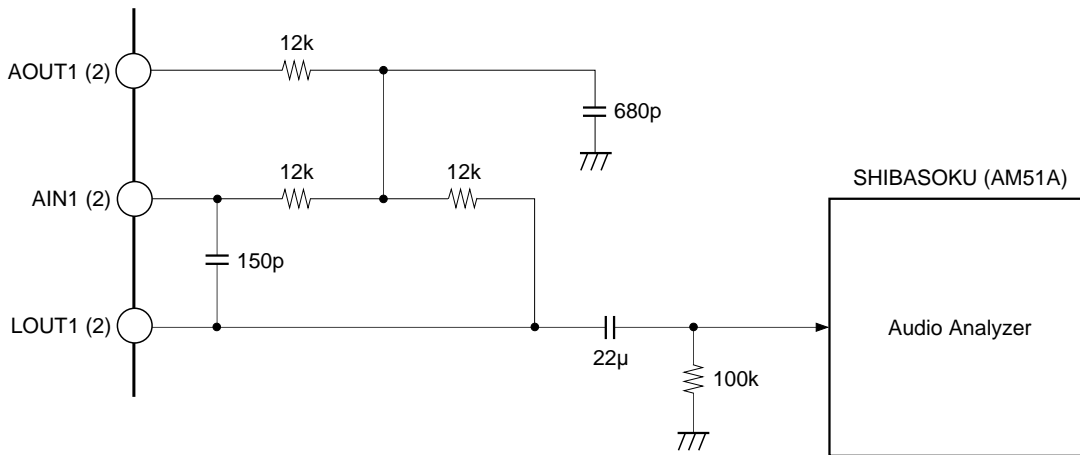

**LPF external circuit diagram**

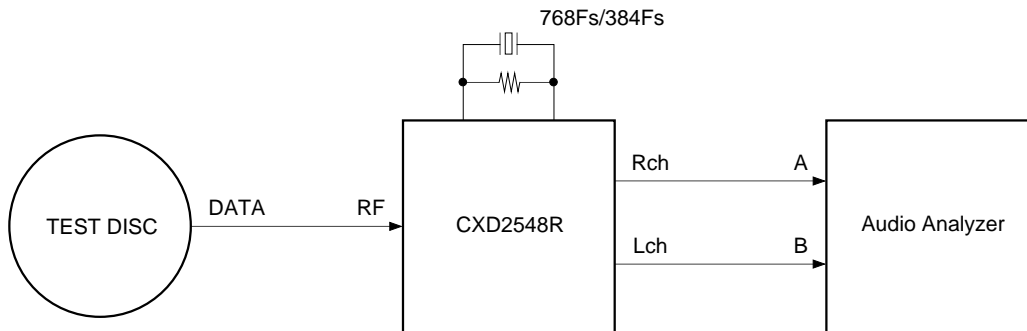

**Block diagram of analog characteristics measurement**

( $V_{DD} = AV_{DD} = 5.0V$ ,  $V_{SS} = AV_{SS} = 0V$ ,  $T_{opr} = -20$  to  $+75^{\circ}C$ )

Item	Symbol	Min.	Typ.	Max.	Unit	Applicable pins
Output voltage	$V_{OUT}$		1.15*		Vrms	*1
Load resistance	$R_L$	8			$k\Omega$	*1

\* When a sine wave of 1kHz and 0dB is output.

#### Applicable pins

\*1 LOUT1, LOUT2

## Contents

### [1] CPU Interface

§1-1. CPU Interface Timing .....	15
§1-2. CPU Interface Command Table .....	16
§1-3. CPU Command Presets .....	25
§1-4. Description of SENS Signals .....	30

### [2] Description of CD Signal Processing and DAC System Commands and Subcode Interface

§2-1. Description of Commands and Data Sets .....	31
§2-2. Subcode Interface .....	50

### [3] Description of Other CD Signal Processing and DAC System Functions

§3-1. Description of DSP Operating Modes .....	55
(a) CLV-N Mode .....	55
(b) CLV-W Mode .....	55
(c) CAV-W Mode .....	55
§3-2. Frame Sync Protection .....	57
§3-3. Error Correction .....	57
§3-4. DA Interface .....	58
§3-5. Digital Out .....	60
§3-6. Servo Auto Sequence .....	60
§3-7. Asymmetry Compensation .....	67
§3-8. Channel Clock Regeneration by the Digital PLL Circuit .....	68
§3-9. Digital CLV .....	70
§3-10. 1-bit DAC Block .....	71
§3-11. LPF Block .....	73
§3-12. Setting the Playback Speed for the CD-DSP and 1-bit DAC Blocks .....	74

### [4] Description of Servo Signal Processing System Functions and Commands

§4-1. General Description of the Servo Signal Processing System .....	75
§4-2. Digital Servo Block Master Clock (MCK) .....	76
§4-3. AVRG Measurement and Compensation .....	76
§4-4. E:F Balance Adjustment Function .....	78
§4-5. FCS Bias Adjustment Function .....	78
§4-6. AGCNTL Function .....	80
§4-7. FCS Servo and FCS Search .....	82
§4-8. TRK and SLD Servo Control .....	83
§4-9. MIRR and DFCT Signal Generation .....	84
§4-10. DFCT Countermeasure Circuit .....	85
§4-11. Anti-Shock Circuit .....	85
§4-12. Brake Circuit .....	86
§4-13. COUT Signal .....	87
§4-14. Serial Readout Circuit .....	87
§4-15. Writing the Coefficient RAM .....	88
§4-16. PWM Output .....	88
§4-17. Servo Status Changes Produced by the LOCK Signal .....	90
§4-18. Description of Commands and Data Sets .....	90
§4-19. List of Servo Filter Coefficients .....	102
§4-20. FILTER Composition .....	104
§4-21. TRACKING and FOCUS Frequency Response .....	111

### [5] Application Circuit

§5-1. Application Circuit .....	112
---------------------------------	-----

Explanation of abbreviations	AVRG: Average
	AGCNTL: auto gain control
	FCS: Focus
	TRK: Tracking
	SLD: Sled
	DFCT: Defect

[1] CPU Interface

§1-1. CPU Interface Timing

• CPU Interface

This interface uses DATA, CLOK, and XLAT to set the modes.

The interface timing chart is shown below.

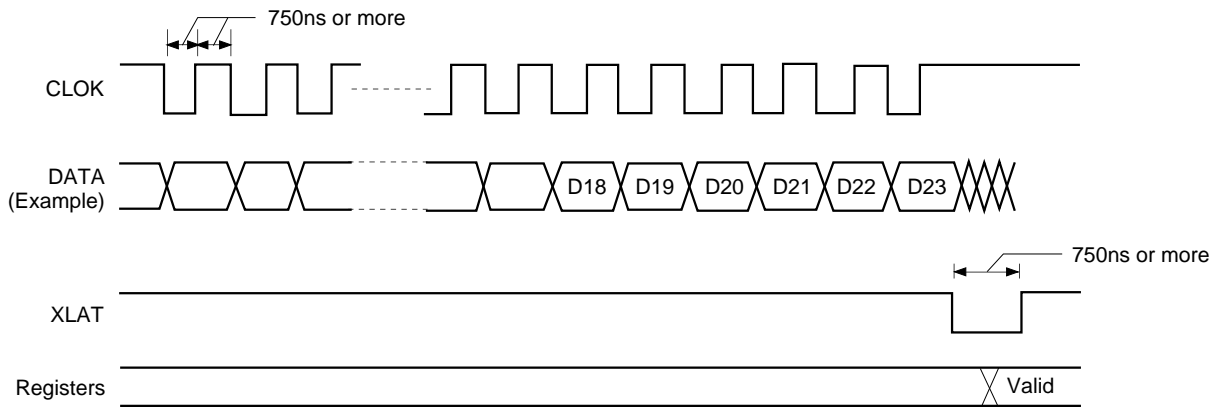

- The internal registers are initialized by a reset when XRST = 0.

**Note)** Be sure to set SQCK to high when XLAT is low.





Command Table (\$340X)

Register	Command	Address 1		Address 2		Address 3		Address 4			Data 1				Data 2							
		D23 to D20	D19 to D16	D15 to D12	D11	D10	D9	D8	D7	D6	D5	D4	D3	D2	D1	D0						
3	SELECT	0 0 1 1	0 1 0 0	0 0 0 0	0	0	0	0	0	KD7	KD6	KD5	KD4	KD3	KD2	KD1	KD0	KRAM DATA (K00) SLED INPUT GAIN				
					0	0	1	0	0	0	0	0	0	0	0	0	0	0	0	0	KRAM DATA (K01) SLED LOW BOOST FILTER A-H	
					0	0	0	1	0	0	0	0	0	0	0	0	0	0	0	0	0	KRAM DATA (K02) SLED LOW BOOST FILTER A-L
					0	0	1	1	0	0	0	0	0	0	0	0	0	0	0	0	0	KRAM DATA (K03) SLED LOW BOOST FILTER B-H
					0	1	0	0	0	0	0	0	0	0	0	0	0	0	0	0	0	KRAM DATA (K04) SLED LOW BOOST FILTER B-L
					0	1	0	1	0	0	0	0	0	0	0	0	0	0	0	0	0	KRAM DATA (K05) SLED OUTPUT GAIN
					0	1	1	0	0	0	0	0	0	0	0	0	0	0	0	0	0	KRAM DATA (K06) FOCUS INPUT GAIN
					0	1	1	1	1	0	0	0	0	0	0	0	0	0	0	0	0	KRAM DATA (K07) SLED AUTO GAIN
					1	0	0	0	0	0	0	0	0	0	0	0	0	0	0	0	0	KRAM DATA (K08) FOCUS HIGH CUT FILTER A
					1	0	0	1	0	0	0	0	0	0	0	0	0	0	0	0	0	KRAM DATA (K09) FOCUS HIGH CUT FILTER B
					1	0	1	0	0	0	0	0	0	0	0	0	0	0	0	0	0	KRAM DATA (K0A) FOCUS LOW BOOST FILTER A-H
					1	0	1	1	1	0	0	0	0	0	0	0	0	0	0	0	0	KRAM DATA (K0B) FOCUS LOW BOOST FILTER A-L
					1	1	0	0	0	0	0	0	0	0	0	0	0	0	0	0	0	KRAM DATA (K0C) FOCUS LOW BOOST FILTER B-H
					1	1	1	0	1	0	0	0	0	0	0	0	0	0	0	0	0	KRAM DATA (K0D) FOCUS LOW BOOST FILTER B-L
					1	1	1	1	0	0	0	0	0	0	0	0	0	0	0	0	0	KRAM DATA (K0E) FOCUS PHASE COMPENSATE FILTER A
					1	1	1	1	1	0	0	0	0	0	0	0	0	0	0	0	0	KRAM DATA (K0F) FOCUS DEFECT HOLD GAIN



Command Table (\$342X)

Register	Command	Address 1		Address 2		Address 3		Address 4				Data 1				Data 2						
		D23 to D20	D19 to D16	D15 to D12	D11	D10	D9	D8	D7	D6	D5	D4	D3	D2	D1	D0						
3	SELECT	0 0 1 1	0 1 0 0	0 0 1 0	0	0	0	0	0	KD7	KD6	KD5	KD4	KD3	KD2	KD1	KD0	KRAM DATA (K20) TRACKING PHASE COMPENSATE FILTER A				
					0	0	1	0	0	0	0	0	0	0	0	0	0	0	0	0	KRAM DATA (K21) TRACKING PHASE COMPENSATE FILTER B	
					0	0	0	1	0	0	0	0	0	0	0	0	0	0	0	0	0	KRAM DATA (K22) TRACKING OUTPUT GAIN
					0	0	0	1	1	0	0	0	0	0	0	0	0	0	0	0	0	KRAM DATA (K23) TRACKING AUTO GAIN
					0	1	0	0	0	0	0	0	0	0	0	0	0	0	0	0	0	KRAM DATA (K24) FOCUS GAIN DOWN HIGH CUT FILTER A
					0	1	0	0	1	0	0	0	0	0	0	0	0	0	0	0	0	KRAM DATA (K25) FOCUS GAIN DOWN HIGH CUT FILTER B
					0	1	1	0	0	0	0	0	0	0	0	0	0	0	0	0	0	KRAM DATA (K26) FOCUS GAIN DOWN LOW BOOST FILTER A-H
					0	1	1	1	0	0	0	0	0	0	0	0	0	0	0	0	0	KRAM DATA (K27) FOCUS GAIN DOWN LOW BOOST FILTER A-L
					1	0	0	0	0	0	0	0	0	0	0	0	0	0	0	0	0	KRAM DATA (K28) FOCUS GAIN DOWN LOW BOOST FILTER B-H
					1	0	0	0	1	0	0	0	0	0	0	0	0	0	0	0	0	KRAM DATA (K29) FOCUS GAIN DOWN LOW BOOST FILTER B-L
					1	0	1	0	0	1	0	0	0	0	0	0	0	0	0	0	0	KRAM DATA (K2A) FOCUS GAIN DOWN PHASE COMPENSATE FILTER A
					1	0	1	0	1	1	0	0	0	0	0	0	0	0	0	0	0	KRAM DATA (K2B) FOCUS GAIN DOWN DEFECT HOLD GAIN
					1	1	0	0	0	0	0	0	0	0	0	0	0	0	0	0	0	KRAM DATA (K2C) FOCUS GAIN DOWN PHASE COMPENSATE FILTER B
					1	1	1	0	1	0	0	0	0	0	0	0	0	0	0	0	0	KRAM DATA (K2D) FOCUS GAIN DOWN OUTPUT GAIN
					1	1	1	1	0	0	0	0	0	0	0	0	0	0	0	0	0	KRAM DATA (K2E) NOT USED
					1	1	1	1	1	0	0	0	0	0	0	0	0	0	0	0	0	KRAM DATA (K2F) NOT USED







Command Table (\$4X to EX)

Register name	Command	Address				Data 1				Data 2				Data 3				Data 4				Data 5				Data 6					
		D27	D26	D25	D24	D23	D22	D21	D20	D19	D18	D17	D16	D15	D14	D13	D12	D11	D10	D9	D8	D7	D6	D5	D4	D3	D2	D1	D0		
4	Auto sequence	0	1	0	0	AS3	AS2	AS1	AS0	—	—	—	—	—	—	—	—	—	—	—	—	—	—	—	—	—	—	—	—		
5	Blind (A, E), Overflow (C)	0	1	0	1	0.18ms	0.09ms	0.05ms	0.02ms	—	—	—	—	—	—	—	—	—	—	—	—	—	—	—	—	—	—	—	—		
	Brake (B)	0	1	0	0	0.36ms	0.18ms	0.09ms	0.05ms	—	—	—	—	—	—	—	—	—	—	—	—	—	—	—	—	—	—	—	—		
6	Kick (D)	0	1	1	0	11.6ms	5.8ms	2.9ms	1.45ms	—	—	—	—	—	—	—	—	—	—	—	—	—	—	—	—	—	—	—	—		
7	Auto sequence (N) track jump count	0	1	1	1	32768	16384	8192	4096	2048	1024	512	256	128	64	32	16	8	4	2	1	—	—	—	—	—	—	—	—		
8	Mode specification	1	0	0	0	GDROM	DOUT Mute	DOUT ON/OFF	WSEL	VCO SEL1	0	SOCT SEL2	VCO SEL2	KSL3	KSL2	KSL1	KSL0	0	0	1	0	—	—	—	—	—	—	—	—	—	
9	Function specification	1	0	0	1	0	DSPB ON/OFF	0	0	0	0	0	0	0	MCSL	CKOSL1	CKOSL0	ZDPL	ZMUT	—	—	—	—	—	—	—	—	—	—	—	
A	Audio CTRL	1	0	1	0	0	0	Mute	ATT	0	0	0	0	0	0	AD9	AD8	AD7	AD6	AD5	AD4	AD3	AD2	AD1	AD0	FMUT	0	0	0	0	
B	Serial bus CTRL	1	0	1	1	SL1	SL0	CPUSR	0	—	—	—	—	—	—	—	—	—	—	—	—	—	—	—	—	—	—	—	—	—	
C	Spindle servo coefficient setting	1	1	0	0	Gain MDP1	Gain MDP0	Gain MDS1	Gain MDS0	—	—	—	—	—	—	—	—	—	—	—	—	—	—	—	—	—	—	—	—	—	
D	CLV CTRL	1	1	0	1	DCLV PWMMD	TB	TP	Gain CLVS	VP7	VP6	VP5	VP4	VP3	VP2	VP1	VP0	—	—	—	—	—	—	—	—	—	—	—	—	—	
E	CLV MODE	1	1	1	0	CM3	CM2	CM1	CM0	EPWM	SPDC	ICAP	SFSL	VC2C	HIFC	LPWR	VPON	Gain CAV1	Gain CAV0	FCSW	0	—	—	—	—	—	—	—	—	—	—

—: Don't care

§1-3. CPU Command Presets

Command Preset Table (\$0X to 34X)

Register	Command	Address																					
		Data 1				Data 2				Data 3				Data 4				Data 5					
		D19	D18	D17	D16	D15	D14	D13	D12	D11	D10	D9	D8	D7	D6	D5	D4	D3	D2	D1	D0		
0	FOCUS CONTROL	0	0	0	0	—	—	—	—	—	—	—	—	—	—	—	—	—	—	—	—	FOCUS SERVO OFF, 0V OUT	
1	TRACKING CONTROL	0	0	0	1	—	—	—	—	—	—	—	—	—	—	—	—	—	—	—	—	TRACKING GAIN UP FILTER SELECT 1	
2	TRACKING MODE	0	0	0	0	—	—	—	—	—	—	—	—	—	—	—	—	—	—	—	—	TRACKING SERVO OFF SLED SERVO OFF	
Register	Command	Address																					
		Data 1				Data 2				Data 3				Data 4				Data 5					
		D19	D18	D17	D16	D15	D14	D13	D12	D11	D10	D9	D8	D7	D6	D5	D4	D3	D2	D1	D0		
3	SELECT	0 0 1 1	0	0	0	0	—	—	—	—	—	—	—	—	—	—	—	—	—	—	—	—	SLED KICK LEVEL (±1 × basic value) (Default)
		See "Coefficient ROM Preset Values Table".																					
		Address 1				Address 2				Address 3				Data 1				Data 2					
		D23 to D20	D19	D18	D17	D16	D15	D14	D13	D12	D11	D10	D9	D8	D7	D6	D5	D4	D3	D2	D1	D0	KRAM DATA (\$3400XX to \$344FXX)

—: Don't care



Command Preset Table (\$4X to EX)

Register name	Command	Address				Data 1				Data 2				Data 3				Data 4				Data 5				Data 6			
		D27	D26	D25	D24	D23	D22	D21	D20	D19	D18	D17	D16	D15	D14	D13	D12	D11	D10	D9	D8	D7	D6	D5	D4	D3	D2	D1	D0
4	Auto sequence	0	1	0	0	0	0	0	0	—	—	—	—	—	—	—	—	—	—	—	—	—	—	—	—	—	—	—	
5	Blind (A, E), Overflow (C)	0	1	0	1	0	1	0	1	—	—	—	—	—	—	—	—	—	—	—	—	—	—	—	—	—	—	—	
	Brake (B)	0	1	0	1	0	1	1	1	—	—	—	—	—	—	—	—	—	—	—	—	—	—	—	—	—	—	—	
6	Kick (D)	0	1	1	0	0	1	1	1	—	—	—	—	—	—	—	—	—	—	—	—	—	—	—	—	—	—	—	
7	Auto sequence (N) track jump count	0	1	1	1	0	0	0	0	0	0	1	0	0	0	0	0	0	0	0	0	—	—	—	—	—	—	—	
8	Mode specification	1	0	0	0	0	0	0	0	0	0	0	0	0	1	0	0	0	1	0	—	—	—	—	—	—	—	—	
9	Function specification	1	0	0	1	0	0	0	0	0	0	0	0	0	0	0	0	0	—	—	—	—	—	—	—	—	—	—	
A	Audio CTRL	1	0	1	0	0	0	0	0	0	0	0	0	0	0	0	0	0	0	0	0	0	0	0	0	0	0	0	
B	Serial bus CTRL	1	0	1	1	0	0	1	0	—	—	—	—	—	—	—	—	—	—	—	—	—	—	—	—	—	—	—	
C	Spindle servo coefficient setting	1	1	0	0	0	0	1	0	—	—	—	—	—	—	—	—	—	—	—	—	—	—	—	—	—	—	—	
D	CLV CTRL	1	1	0	1	0	0	0	0	1	1	0	0	0	0	0	—	—	—	—	—	—	—	—	—	—	—	—	
E	CLV MODE	1	1	1	0	0	0	0	0	0	0	0	0	0	0	0	0	0	0	0	0	—	—	—	—	—	—	—	

—: Don't care

&lt;Coefficient ROM Preset Values Table (1)&gt;

ADDRESS	DATA	CONTENTS
K00	E0	SLED INPUT GAIN
K01	81	SLED LOW BOOST FILTER A-H
K02	23	SLED LOW BOOST FILTER A-L
K03	7F	SLED LOW BOOST FILTER B-H
K04	6A	SLED LOW BOOST FILTER B-L
K05	10	SLED OUTPUT GAIN
K06	14	FOCUS INPUT GAIN
K07	30	SLED AUTO GAIN
K08	7F	FOCUS HIGH CUT FILTER A
K09	46	FOCUS HIGH CUT FILTER B
K0A	81	FOCUS LOW BOOST FILTER A-H
K0B	1C	FOCUS LOW BOOST FILTER A-L
K0C	7F	FOCUS LOW BOOST FILTER B-H
K0D	58	FOCUS LOW BOOST FILTER B-L
K0E	82	FOCUS PHASE COMPENSATE FILTER A
K0F	7F	FOCUS DEFECT HOLD GAIN
K10	4E	FOCUS PHASE COMPENSATE FILTER B
K11	32	FOCUS OUTPUT GAIN
K12	20	ANTI SHOCK INPUT GAIN
K13	30	FOCUS AUTO GAIN
K14	80	HPTZC / Auto Gain HIGH PASS FILTER A
K15	77	HPTZC / Auto Gain HIGH PASS FILTER B
K16	80	ANTI SHOCK HIGH PASS FILTER A
K17	77	HPTZC / Auto Gain LOW PASS FILTER B
K18	00	Fix*
K19	F1	TRACKING INPUT GAIN
K1A	7F	TRACKING HIGH CUT FILTER A
K1B	3B	TRACKING HIGH CUT FILTER B
K1C	81	TRACKING LOW BOOST FILTER A-H
K1D	44	TRACKING LOW BOOST FILTER A-L
K1E	7F	TRACKING LOW BOOST FILTER B-H
K1F	5E	TRACKING LOW BOOST FILTER B-L
K20	82	TRACKING PHASE COMPENSATE FILTER A
K21	44	TRACKING PHASE COMPENSATE FILTER B
K22	18	TRACKING OUTPUT GAIN
K23	30	TRACKING AUTO GAIN
K24	7F	FOCUS GAIN DOWN HIGH CUT FILTER A
K25	46	FOCUS GAIN DOWN HIGH CUT FILTER B
K26	81	FOCUS GAIN DOWN LOW BOOST FILTER A-H
K27	3A	FOCUS GAIN DOWN LOW BOOST FILTER A-L
K28	7F	FOCUS GAIN DOWN LOW BOOST FILTER B-H
K29	66	FOCUS GAIN DOWN LOW BOOST FILTER B-L
K2A	82	FOCUS GAIN DOWN PHASE COMPENSATE FILTER A
K2B	44	FOCUS GAIN DOWN DEFECT HOLD GAIN
K2C	4E	FOCUS GAIN DOWN PHASE COMPENSATE FILTER B
K2D	1B	FOCUS GAIN DOWN OUTPUT GAIN
K2E	00	NOT USED
K2F	00	NOT USED

&lt;Coefficient ROM Preset Values Table (2)&gt;

ADDRESS	DATA	CONTENTS
K30	80	Fix*
K31	66	ANTI SHOCK LOW PASS FILTER B
K32	00	NOT USED
K33	7F	ANTI SHOCK HIGH PASS FILTER B-H
K34	6E	ANTI SHOCK HIGH PASS FILTER B-L
K35	20	ANTI SHOCK FILTER COMPARATE GAIN
K36	7F	TRACKING GAIN UP2 HIGH CUT FILTER A
K37	3B	TRACKING GAIN UP2 HIGH CUT FILTER B
K38	80	TRACKING GAIN UP2 LOW BOOST FILTER A-H
K39	44	TRACKING GAIN UP2 LOW BOOST FILTER A-L
K3A	7F	TRACKING GAIN UP2 LOW BOOST FILTER B-H
K3B	77	TRACKING GAIN UP2 LOW BOOST FILTER B-L
K3C	86	TRACKING GAIN UP PHASE COMPENSATE FILTER A
K3D	0D	TRACKING GAIN UP PHASE COMPENSATE FILTER B
K3E	57	TRACKING GAIN UP OUTPUT GAIN
K3F	00	NOT USED
K40	04	TRACKING HOLD FILTER INPUT GAIN
K41	7F	TRACKING HOLD FILTER A-H
K42	7F	TRACKING HOLD FILTER A-L
K43	79	TRACKING HOLD FILTER B-H
K44	17	TRACKING HOLD FILTER B-L
K45	6D	TRACKING HOLD FILTER OUTPUT GAIN
K46	00	NOT USED
K47	00	NOT USED
K48	02	FOCUS HOLD FILTER INPUT GAIN
K49	7F	FOCUS HOLD FILTER A-H
K4A	7F	FOCUS HOLD FILTER A-L
K4B	79	FOCUS HOLD FILTER B-H
K4C	17	FOCUS HOLD FILTER B-L
K4D	54	FOCUS HOLD FILTER OUTPUT GAIN
K4E	00	NOT USED
K4F	00	NOT USED

\* Fix indicates that normal preset values should be used.

## §1-4. Description of SENS Signals

### SENS output

Microcomputer serial register (latching not required)	ASEQ = 1	Output data length
\$0X	FZC	—
\$1X	AS	—
\$2X	TZC	—
\$38	AGOK*1	—
\$38	XAVEBSY*1	—
\$30 to 37, \$3A to 3F	SSTP	—
\$3900	VC In Reg.	8 bit
\$3901	SLD In Reg.	8 bit
\$3902	TRK In Reg.	8 bit
\$3903	FCS In Reg.	8 bit
\$3904	TE Avg Reg.	9 bit
\$3908	FE Avg Reg.	9 bit
\$390C	VC Avg Reg.	9 bit
\$391C	TRVSC Reg.	9 bit
\$391D	FB Reg.	9 bit
\$391E	RFDC In Reg.	8 bit
\$391F	RFDC Avg Reg.	8 bit
\$3920 to \$393F	Address 5-bit (M00 to 1F) data RAM data	16 bit
\$3940 to \$397F	Address 6-bit (K00 to 3F) coefficient RAM data	8 bit
\$4X	XBUSY	—
\$5X	FOK	—
\$6X	0	—
\$AX	GFS	—
\$EX	$\overline{\text{OV64}}$	—
\$7X, 8X, 9X, BX, CX, DX, FX	0	—

\*1 \$38 outputs AGOK during AGT and AGF command settings, and XAVEBSY during AVRG measurement. SSTP is output in all other cases.

**Note)** The SENS output can be read from the SQSO pin when SOCT = 0, SL1 = 1 and SL0 = 0. (See "\$BX Commands".)

### Description of SENS Signals

SENS output	
XBUSY	Low while the auto sequencer is in operation, high when operation terminates.
FOK	Outputs the same signal as the FOK pin. High for "focus OK".
GFS	High when the regenerated frame sync is obtained with the correct timing.
$\overline{\text{OV64}}$	Low when the EFM signal is lengthened by 64 channel lock pulses or more after passing through the sync detection filter.

## [2] Description of CD Signal Processing and DAC System Commands and Subcode Interface

### 2-1. Description of Commands and Data Sets

#### \$4X commands

Command	AS3	AS2	AS1	AS0
CANCEL	0	0	0	0
FOCUS-ON	0	1	1	1
1 TRACK JUMP	1	0	0	RXF
10 TRACK JUMP	1	0	1	RXF
2 NTRACK JUMP	1	1	0	RXF
N TRACK MOVE	1	1	1	RXF

RXF = 0 FORWARD

RXF = 1 REVERSE

- When the Focus-on command (\$47) is canceled, \$02 is sent and the auto sequence is interrupted.
- When the Track jump/Move commands (\$48 to \$4F) are canceled, \$25 is sent and the auto sequence is interrupted.

#### \$5X commands

Auto sequence timer setting

Set timers: A, E, C, B

Command	D23	D22	D21	D20
Blind (A, E), Over flow (C)	0.18ms	0.09ms	0.05ms	0.02ms
Brake (B)	0.36ms	0.18ms	0.09ms	0.05ms

e.g.) D2 = D0 = 1, D3 = D1 = 0 (Initial Reset)

A = E = C = 0.11ms

B = 0.23ms

#### \$6X commands

Auto sequence timer setting

Set timer: D

Command	D23	D22	D21	D20
KICK (D)	11.6ms	5.8ms	2.9ms	1.45ms

e.g.) D3 = 0, D2 = D1 = D0 = 1 (Initial Reset)

D = 10.15ms

#### \$7X commands

Auto sequence track jump/move count setting (N)

Command	Data 1				Data 2				Data 3				Data 4			
	D23	D22	D21	D20	D19	D18	D17	D16	D15	D14	D13	D12	D11	D10	D9	D8
Auto sequence track jump count setting	2 <sup>15</sup>	2 <sup>14</sup>	2 <sup>13</sup>	2 <sup>12</sup>	2 <sup>11</sup>	2 <sup>10</sup>	2 <sup>9</sup>	2 <sup>8</sup>	2 <sup>7</sup>	2 <sup>6</sup>	2 <sup>5</sup>	2 <sup>4</sup>	2 <sup>3</sup>	2 <sup>2</sup>	2 <sup>1</sup>	2 <sup>0</sup>

This command is used to set N when a 2N-track jump or N-track move is executed for auto sequence.

- The maximum track count is 65,535, but note that with a 2N-track jump the maximum track jump count depends on the mechanical limitations of the optical system.
- When the track jump count is from 0 to 15, the COUT signal is counted; when the count is 16 or over, the MIRR signal is counted.

**\$8X commands**

Command	Data 1				Data 2				Data 3			
	D23	D22	D21	D20	D19	D18	D17	D16	D15	D14	D13	D12
Mode specification	CDROM	DOUT Mute	DOUT ON/OFF	WSEL	VCO SEL1	0	SOCT	VCO SEL2	KSL3	KSL2	KSL1	KSL0

See "\$BX Commands".

Data 4			
D11	D10	D9	D8
0	0	1	0

Command bit	C2PO timing	Processing
CDROM = 1	See Timing Chart 1-1.	CDROM mode; average value interpolation and pre-value hold are not performed.
CDROM = 0	See Timing Chart 1-1.	Audio mode; average value interpolation and pre-value hold are performed.

Command bit	Processing
DOUT Mute = 1	Digital Out output is muted. (DA output is not muted.)
DOUT Mute = 0	If other mute conditions are not set, Digital Out is not muted.

Command bit	Processing
DOUT ON/OFF = 1	Digital Out is output from the DOUT pin.
DOUT ON/OFF = 0	Digital Out is not output from the DOUT pin.

Command bit	Sync protection window width	Application
WSEL = 1	$\pm 26$ channel clock*1	Anti-rolling is enhanced.
WSEL = 0	$\pm 6$ channel clock	Sync window protection is enhanced.

\*1 In normal-speed playback, channel clock = 4.3218MHz.

Command bit			Processing
VCOSEL1	KSL3	KSL2	
0	0	0	Multiplier PLL VCO1 is set to normal speed, and the output is 1/1 frequency-divided.
0	0	1	Multiplier PLL VCO1 is set to normal speed, and the output is 1/2 frequency-divided.
0	1	0	Multiplier PLL VCO1 is set to normal speed, and the output is 1/4 frequency-divided.
0	1	1	Multiplier PLL VCO1 is set to normal speed, and the output is 1/8 frequency-divided.
1	0	0	Multiplier PLL VCO1 is set to high speed*1, and the output is 1/1 frequency-divided.
1	0	1	Multiplier PLL VCO1 is set to high speed*1, and the output is 1/2 frequency-divided.
1	1	0	Multiplier PLL VCO1 is set to high speed*1, and the output is 1/4 frequency-divided.
1	1	1	Multiplier PLL VCO1 is set to high speed*1, and the output is 1/8 frequency-divided.

\*1 Approximately twice the normal speed

Command bit			Processing
VCOSEL2	KSL1	KSL0	
0	0	0	Wide-band PLL VCO2 is set to normal speed, and the output is 1/1 frequency-divided.
0	0	1	Wide-band PLL VCO2 is set to normal speed, and the output is 1/2 frequency-divided.
0	1	0	Wide-band PLL VCO2 is set to normal speed, and the output is 1/4 frequency-divided.
0	1	1	Wide-band PLL VCO2 is set to normal speed, and the output is 1/8 frequency-divided.
1	0	0	Wide-band PLL VCO2 is set to high speed*2, and the output is 1/1 frequency-divided.
1	0	1	Wide-band PLL VCO2 is set to high speed*2, and the output is 1/2 frequency-divided.
1	1	0	Wide-band PLL VCO2 is set to high speed*2, and the output is 1/4 frequency-divided.
1	1	1	Wide-band PLL VCO2 is set to high speed*2, and the output is 1/8 frequency-divided.

\*2 Approximately twice the normal speed

Timing Chart 2-1

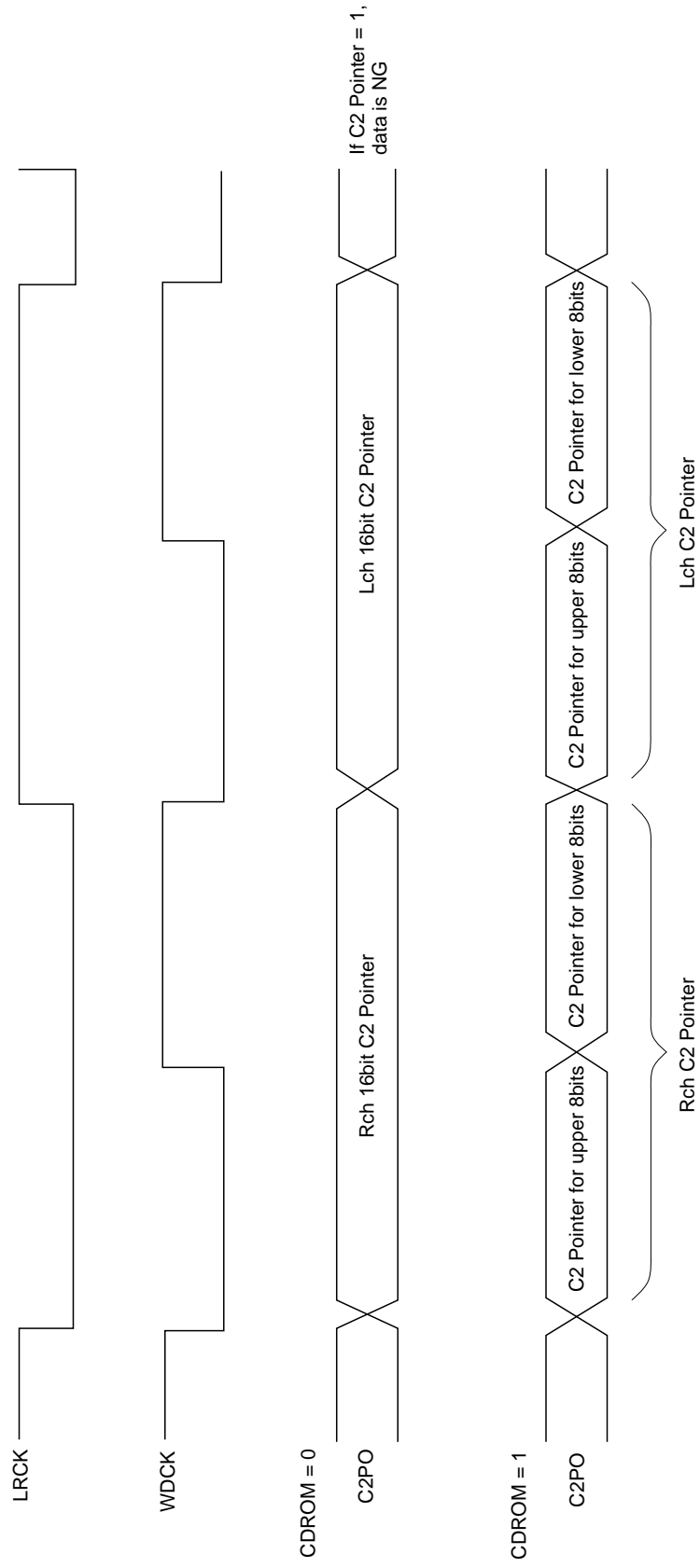

**\$9X commands**

\* Data 3 and subsequent data are DF/DAC function settings.

Command	Data 1				Data 2	Data 3				Data 4			
	D23	D22	D21	D20	D19 to D16	D15	D14	D13	D12	D11	D10	D9	D8
Function specification	0	DSPB ON/OFF	0	0	0 0 0 0	0	MCSL	CKOSL1	CKOSL0	ZDPL	ZMUT	—	—

Command bit	Processing
DSPB = 1	Double-speed playback (CD-DSP block)
DSPB = 0	Normal-speed playback (CD-DSP block)

Command bit	Processing
MCSL = 1	DF/DAC block master clock selection. Crystal = 768Fs (33.8688MHz).
MCSL = 0	DF/DAC block master clock selection. Crystal = 384Fs (16.9344MHz).

Command bit		Processing
CKOSL1	CKOSL0	
0	0	CKOUT pin output is the 1/1 frequency-divided crystal input.
0	1	CKOUT pin output is the 1/2 frequency-divided crystal input.
1	0	CKOUT pin output is the 1/4 frequency-divided crystal input.
1	1	CKOUT pin output is fixed low.

Command bit	Processing
ZDPL = 1	Mute flag (LMUT2 and RMUT1 pins) polarity setting. Muted when high.
ZDPL = 0	Mute flag (LMUT2 and RMUT1 pins) polarity setting. Muted when low.

Command bit	Processing
ZMUT = 1	Zero detection mute on.
ZMUT = 0	Zero detection mute off.

**\$AX commands**

\* Data 2 and subsequent data are DF/DAC function settings.

Command	Data 1				Data 2				Data 3			
	D23	D22	D21	D20	D19	D18	D17	D16	D15	D14	D13	D12
Audio CTRL	0	0	Mute	ATT	0	0	OPSL	EMPH	SMUT	0	AD9	AD8

Data 4				Data 5				Data 6			
D11	D10	D9	D8	D7	D6	D5	D4	D3	D2	D1	D0
AD7	AD6	AD5	AD4	AD3	AD2	AD1	AD0	FMUT	0	0	0

Command bit	Processing
Mute = 1	Mute on. Zero data is output from DSP.
Mute = 0	Mute off.

Command bit	Processing
ATT = 1	DSP output -12dB
ATT = 0	Attenuation off

Command bit	Processing
OPSL = 1	Set to 1 when changing the FMUT setting.
OPSL = 0	Set to 0 when not changing the FMUT setting.

Command bit	Processing
EMPH = 1	De-emphasis on.
EMPH = 0	De-emphasis off.

\* If either the EMPHI pin or EMPH are high, de-emphasis is on.

Command bit	Processing
SMUT = 1	Soft mute on.
SMUT = 0	Soft mute off.

\* If either the SYSM pin or SMUT are high, soft mute is on.

Command bit	Processing
AD9 to 0	Attenuation data

The attenuation data is 10 bits, and is set as follows.

Attenuation data	Audio output
3FFh	0dB
3FEh	-0.0085dB
3FEh	-0.017dB
:	
001h	-60.198dB
000h	-∞

Command bit	Processing
FMUT = 1	Forced mute on.
FMUT = 0	Forced mute off.

\* FMUT can be set when OPSL is high.

**\$BX commands**

Command	Data 1			
	D3	D2	D1	D0
Serial bus CTRL	SL1	SL0	CPUSR	0

SOCT	SL1	SL0	mode
0	0	0	SubQ
0	0	1	Peak meter
0	1	0	SENS
0	1	1	D
1	0	0	SubQ
1	0	1	A
1	1	0	B
1	1	1	C

The SQSO pin output is switched to the various signals by setting the SOCT command of \$BX and the SL1 and SL0 commands of \$BX. Set SQCK to high at the fall of XLAT. Modes other than Sub Q and peak meter are loaded to the register when set at the fall of XLAT. Sub Q is loaded to the register with each SCOR, and peak meter is loaded during peak detection.

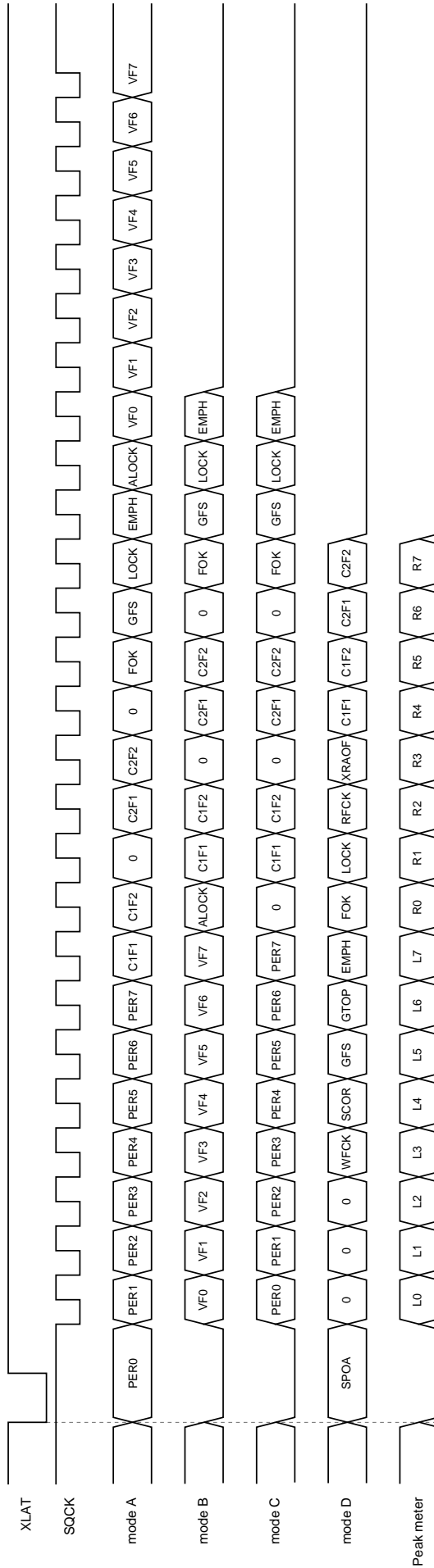

Signal	Description
PER0 to 7	RF jitter amount (used to adjust the focus bias). 8-bit binary data in PER0 = LSB, PER7 = MSB.
FOX	Focus OK
GFS	High when the frame sync and the insertion protection timing match.
LOCK	GFS is sampled at 460Hz; when GFS is high, a high signal is output. If GFS is low eight consecutive samples, a low signal is output.
EMPH	High when the playback disc has emphasis.
ALOCK	GFS is sampled at 460Hz; when GFS is high eight consecutive samples, a high signal is output. If GFS is low eight consecutive samples, a low signal is output.
VF0 to 7	Used during CAV-W mode. Disc rotational speed measurement results. (See Timing Chart 2-3.) VF0 = LSB, VF7 = MSB.
SPOA	SPOA pin input
WFCK	Write frame clock output
SCOR	High when either subcode sync S0 or S1 is detected.
GTOP	High when the sync protection window is open.
RFCK	Read frame clock output
XRAOF	Low when the built-in 16K RAM exceeds the $\pm 4$ frame jitter margin.
L0 to L7, R0 to R7	Peak meter register output. Lch L0 to 7 and Rch R0 to 7 peak data. L0 and R0 are LSB.

C1F1	C1F2	C1 correction status
0	0	No Error
1	0	Single Error Correction
1	1	Irretrievable Error

C2F1	C2F2	C2 correction status
0	0	No Error
1	0	Single Error Correction
1	1	Irretrievable Error

Command bit	Processing
CPUSR = 1	XLON pin is high.
CPUSR = 0	XLON pin is low.

## Peak Meter

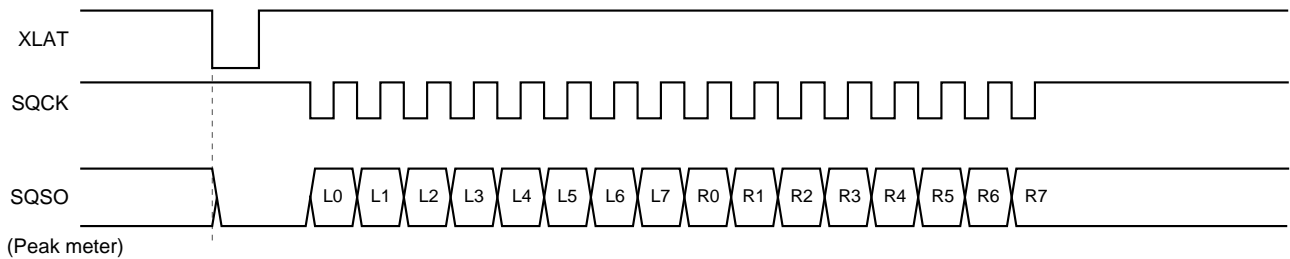

Setting the SOCT command of \$8X to 0 and the SL1 and SL0 commands of \$BX to 0 and 1, respectively, results in peak detection mode. The SQSO output is connected to the peak register. The maximum PCM data values (absolute value, upper 8 bits) for Lch and Rch can be read from SQSO by inputting 16 clocks to SQCK. Peak detection is not performed during SQCK input, and the peak register does not change during readout. This SQCK input judgment uses a retriggerable monostable multivibrator with a time constant of 270 $\mu$ s to 400 $\mu$ s. The time during which SQCK input is high should be 270  $\mu$ s or less. Also, peak detection is restarted 270 $\mu$ s to 400 $\mu$ s after SQCK input.

The peak detection register is reset with each readout (16 clocks input to SQCK).

The maximum value during peak detection mode is detected and held in this status until the next readout. When switching to peak detection mode, readout should be performed one time initially to reset the peak detection register.

Peak detection can also be performed for previous value hold and average value interpolation data.

**\$CX commands**

Command	D23	D22	D21	D20
Servo coefficient setting	Gain MDP1	Gain MDP0	Gain MDS1	Gain MDS0
CLV CTRL (\$DX)				Gain CLVS

• CLV mode gain setting: GCLVS

Gain MDS1	Gain MDS0	Gain CLVS	GCLVS
0	0	0	-12dB
0	0	1	-6dB
0	1	0	-6dB
0	1	1	0dB
1	0	0	0dB
1	0	1	+6dB

• CLVP mode gain setting: GMDP, GMDS

Gain MDP1	Gain MDP0	GMDP
0	0	-6dB
0	1	0dB
1	0	+6dB

Gain MDS1	Gain MDS0	GMDS
0	0	-6dB
0	1	0dB
1	0	+6dB

**\$DX commands**

Command	Data 1				Data 2				Data 3			
	D23	D22	D21	D20	D19	D18	D17	D16	D15	D14	D13	D12
CLV CTRL	DCLV PWM MD	TB	TP	Gain CLVS	VP7	VP6	VP5	VP4	VP3	VP2	VP1	VP0

See "\$CX Commands".

Command bit	Description
DCLV PWM MD = 1	Digital CLV PWM mode specified. Both MDS and MDP are used. CLV-W and CAV-W modes can not be used.
DCLV PWM MD = 0	Digital CLV PWM mode specified. Ternary MDP values are output. CLV-W and CAV-W modes can be used.

Command bit	Description
TB = 0	Bottom hold at a cycle of RFCK/32 in CLVS mode.
TB = 1	Bottom hold at a cycle of RFCK/16 in CLVS mode.
TP = 0	Peak hold at a cycle of RFCK/4 in CLVS mode.
TP = 1	Peak hold at a cycle of RFCK/2 in CLVS mode.

Command bit	Description
VP0 to 7 = F0 (H)	Playback at half (normal) speed to
:	
VP0 to 7 = E0 (H)	Playback at normal (double) speed

The rotational velocity R of the spindle can be expressed with the following equation.

$$R = \frac{256 - n}{32}$$

R: Relative velocity at normal speed = 1  
 n: VP0 to 7 setting value

**Notes)**

- 1) Values in parentheses are for when DSPB is 1.
- 2) Values when the crystal is 16.9344MHz and XTSL is low or when the crystal is 33.8688MHz and XTSL is high.
- 3) The VP0 to 7 setting values are valid in CAV-W mode.

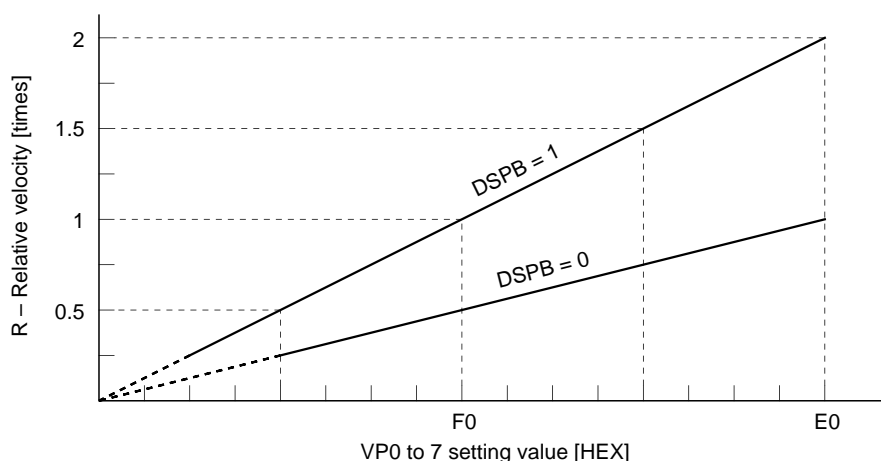

**Fig. 2-1.**

**\$EX commands**

Command	Data 1				Data 2				Data 3			
	D23	D22	D21	D20	D19	D18	D17	D16	D15	D14	D13	D12
CLV mode	CM3	CM2	CM1	CM0	EPWM	SPDC	ICAP	SFSL	VC2C	HIFC	LPWR	VPON

Command bit				Mode	Description
CM3	CM2	CM1	CM0		
0	0	0	0	STOP	Spindle stop mode. *1
1	0	0	0	KICK	Spindle forward rotation mode. *1
1	0	1	0	BRAKE	Spindle reverse rotation mode. Valid only when LPWR = 0 in any modes. *1
1	1	1	0	CLVS	Rough servo mode. When the RF-PLL circuit isn't locked, this mode is used to pull the disc rotations within the RF-PLL capture range.
1	1	1	1	CLVP	PLL servo mode.
0	1	1	0	CLVA	Automatic CLVS/CLVP switching mode. Used for normal playback.

\*1 See Timing Charts 1-6 to 1-12.

Command bit								Mode	Description
EPWM	SPDC	ICAP	SFSL	VC2C	HIFC	LPWR	VPON		
0	0	0	0	0	0	0	0	CLV-N	Crystal reference CLV servo.
0	0	0	0	1	1	0	0	CLV-W	Used for playback in CLV-W mode. *2
0	1	1	0	0	1	0	1	CAV-W	Spindle control with VP0 to 7.
1	0	1	0	0	1	0	1	CAV-W	Spindle control with the external PWM.

\*2 Figs. 3-1 and 3-2 show the control flow with the microcomputer software in CLV-W mode.

Command	Data 4			
	D11	D10	D9	D8
SPD mode	Gain CAV1	Gain CAV0	FCSW	0

Gain CAV1	Gain CAV0	Gain
0	0	0dB
0	1	-6dB
1	0	-12dB
1	1	-18dB

- This sets the gain when controlling the spindle with the phase comparator in CAV-W mode.

Command bit	Processing
FCSW = 0	The VPCO2 pin is not used and it is Hi-Z.
FCSW = 1	The VPCO2 pin is used and the pin signal is the same as VPCO1.

Mode	DCLV PWM MD	LPWR	Command	Timing chart
CLV-N	0	0	KICK	2-2 (a)
			BRAKE	2-2 (b)
			STOP	2-2 (c)
	1	0	KICK	2-3 (a)
			BRAKE	2-3 (b)
			STOP	2-3 (c)
CLV-W	0	0	KICK	2-4 (a)
			BRAKE	2-4 (b)
			STOP	2-4 (c)
		1	KICK	2-5 (a)
			BRAKE	2-5 (b)
			STOP	2-5 (c)
CAV-W	0	0	KICK	2-6 (a)
			BRAKE	2-6 (b)
			STOP	2-6 (c)
		1	KICK	2-7 (a)
			BRAKE	2-7 (b)
			STOP	2-7 (c)

Mode	DCLV PWM MD	LPWR	Timing chart
CLV-N	0	0	2-8
	1	0	2-9
CLV-W	0	0	2-10
		1	2-11
CAV-W	0	0	2-12 (EPWM = 0)
		1	2-13 (EPWM = 0)
		0	2-14 (EPWM = 1)
		1	2-15 (EPWM = 1)

**Note)** CLV-W and CAV-W modes support control only by the ternary output of the MDP pin.  
Therefore, set DCLV PWM MD to 0 in CLV-W and CAV-W modes.

**Timing Chart 2-2**

**CLV-N mode** DCLV PWM MD = LPWR = 0

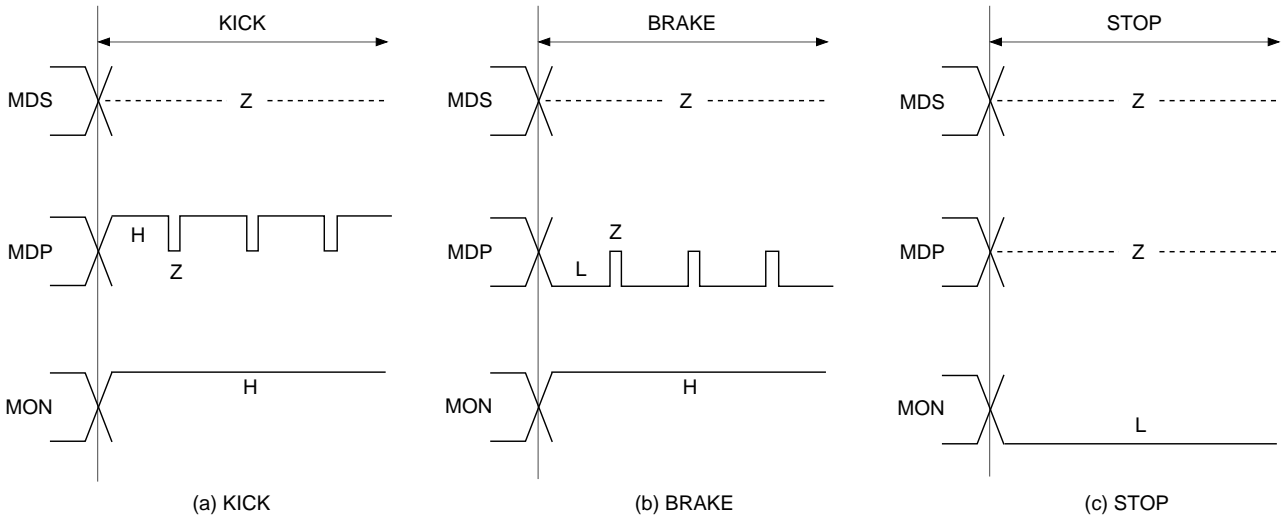

**Timing Chart 2-3**

**CLV-N mode** DCLV PWM MD = 1, LPWR = 0

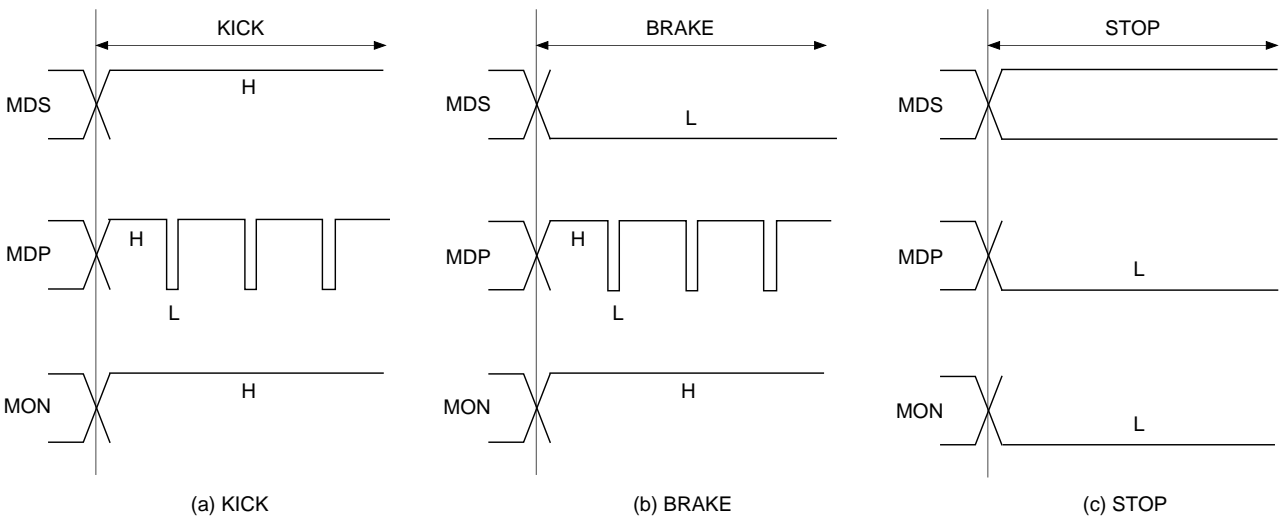

**Timing Chart 2-4**

**CLV-W mode (when following the spindle rotational velocity)** DCLV PWM MD = LPWR = 0

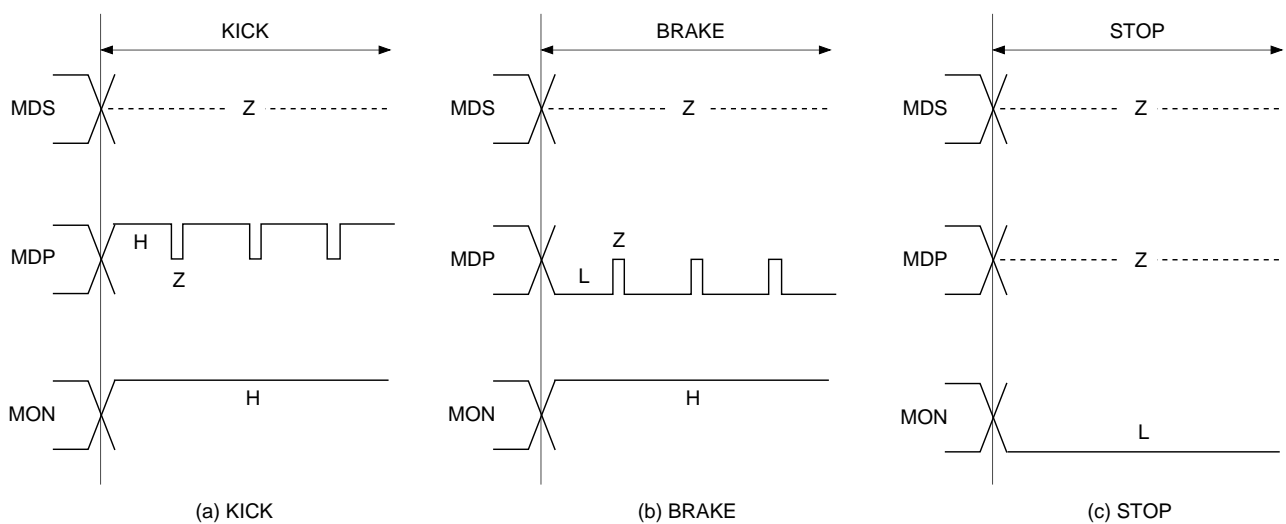

**Timing Chart 2-5**

**CLV-W mode (when following the spindle rotational velocity) DCLV PWM MD = 0, LPWR = 1**

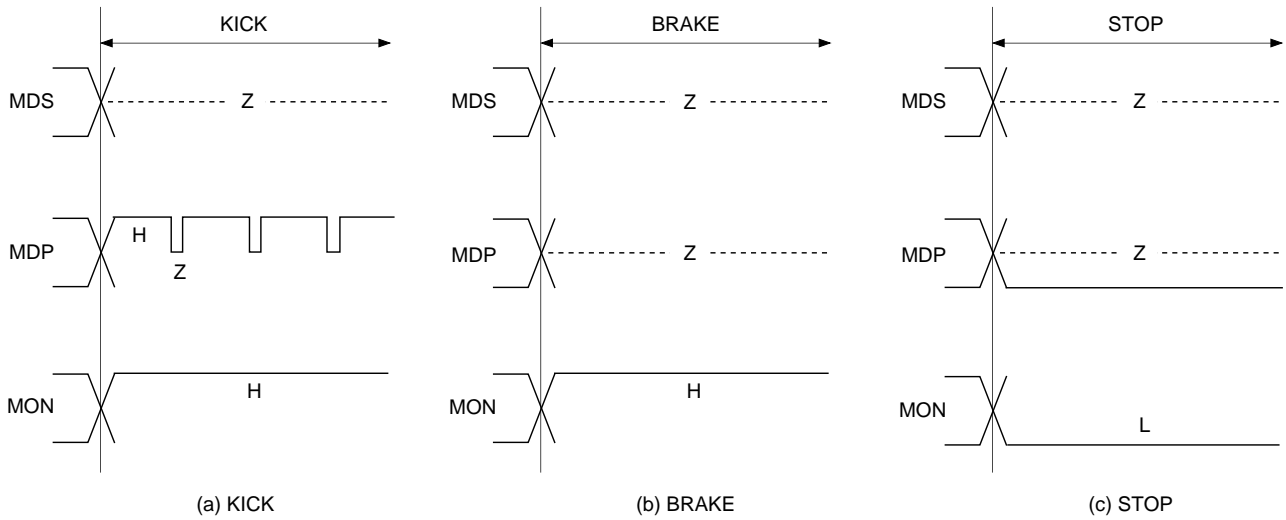

**Timing Chart 2-6**

**CAV-W mode DCLV PWM MD = LPWR = 0**

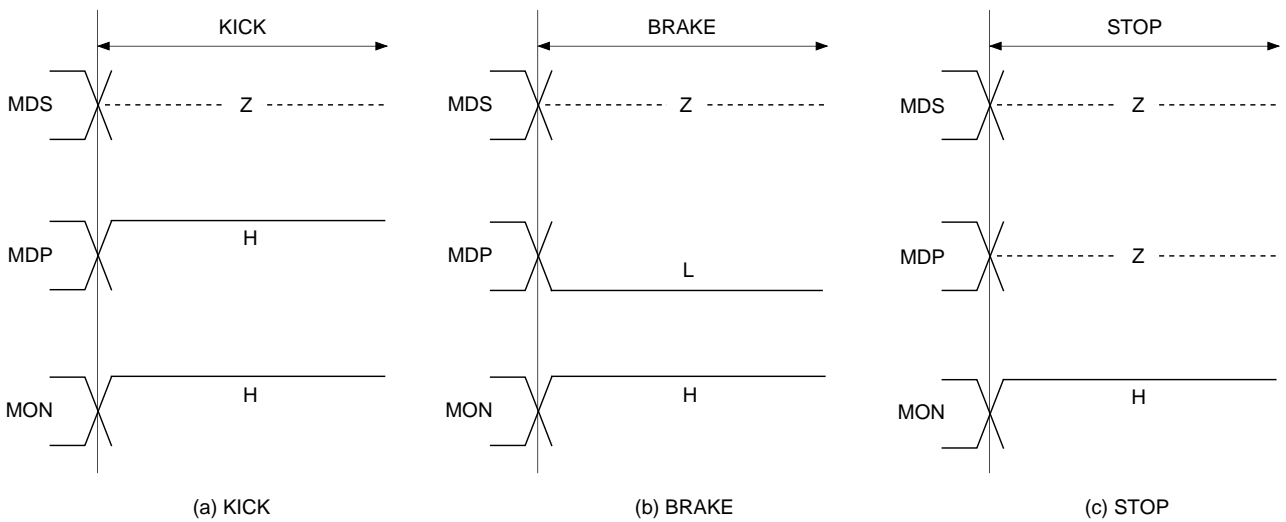

**Timing Chart 2-7**

**CAV-W mode DCLV PWM MD = 0, LPWR = 1**

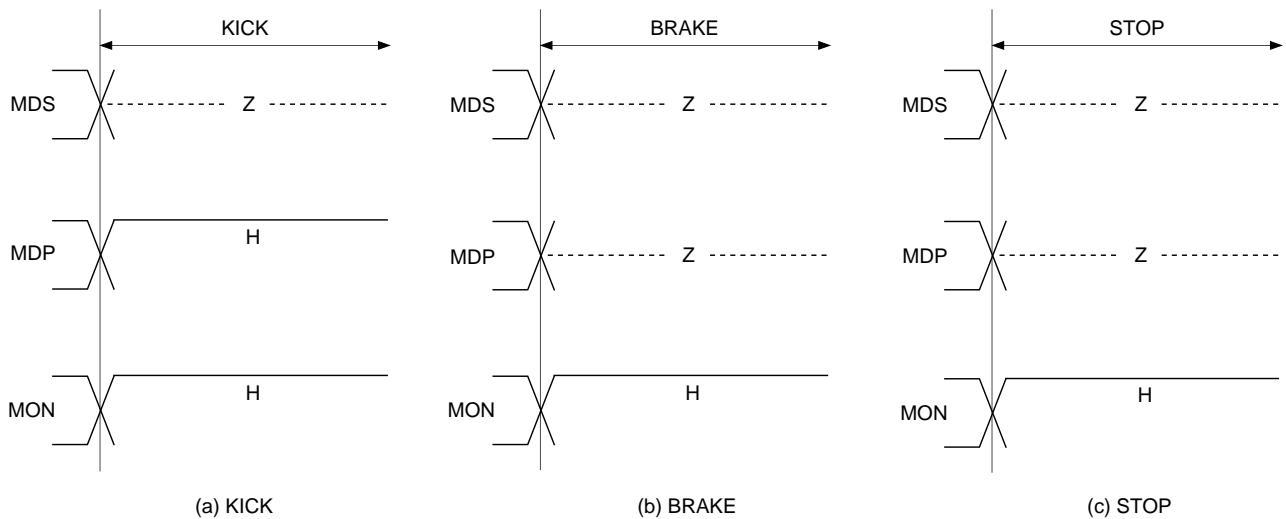

**Timing Chart 2-8**

**CLV-N mode** DCLV PWM MD = LPWR = 0

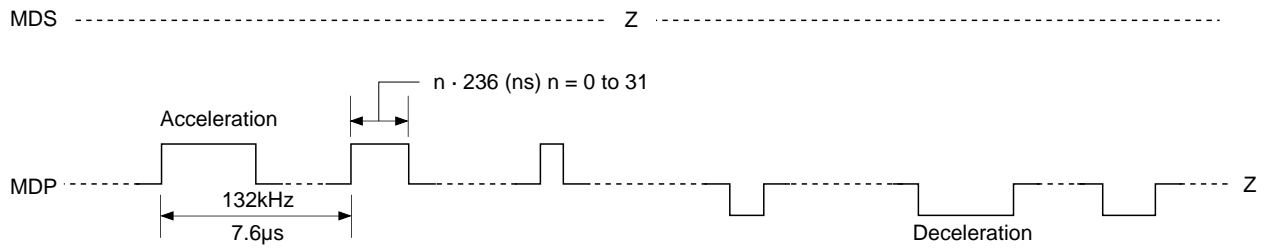

**Timing Chart 2-9**

**CLV-N mode** DCLV PWM MD = 1, LPWR = 0

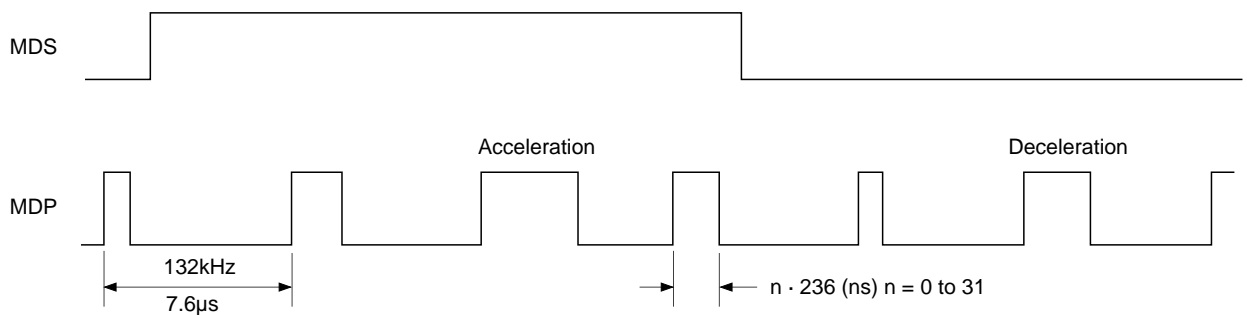

**Timing Chart 2-10**

**CLV-W mode** DCLV PWM MD = LPWR = 0

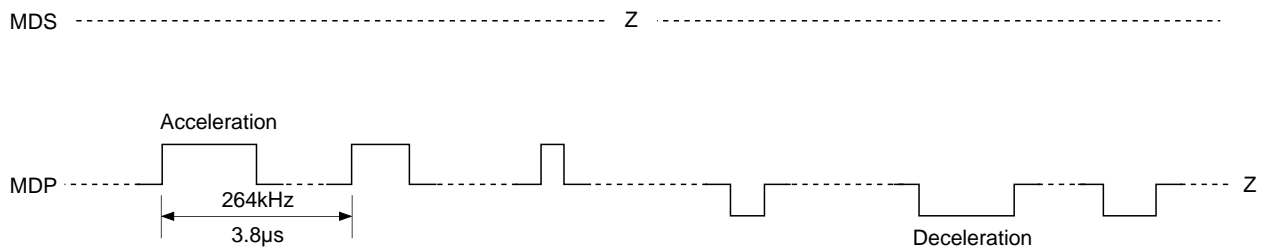

**Timing Chart 2-11**

**CLV-W mode** DCLV PWM MD = 0, LPWR = 1

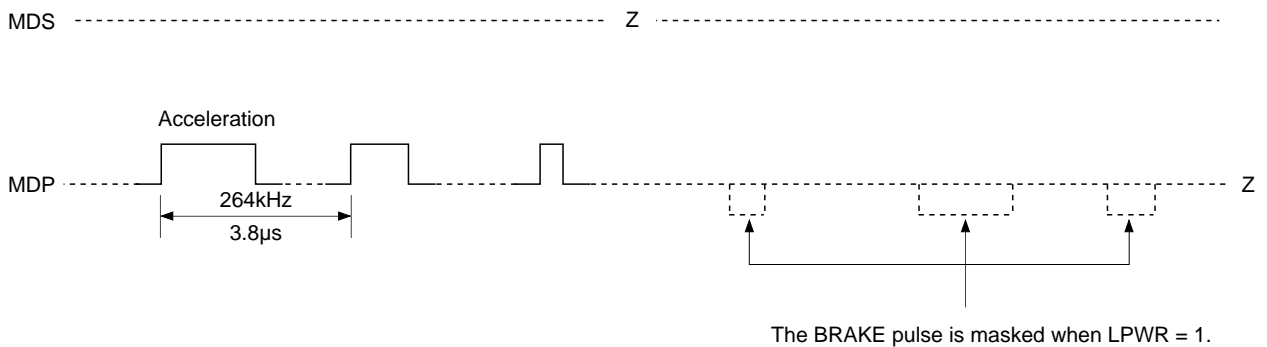

**Timing Chart 2-12**

**CAV-W mode** EPWM = DCLV PWM MD = LPWR = 0

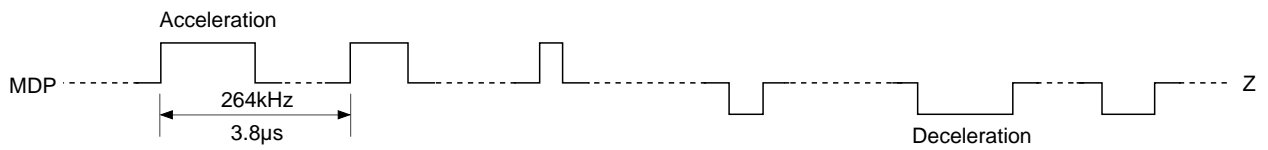

**Timing Chart 2-13**

**CAV-W mode** EPWM = 1, DCLV PWM MD = 0, LPWR = 1

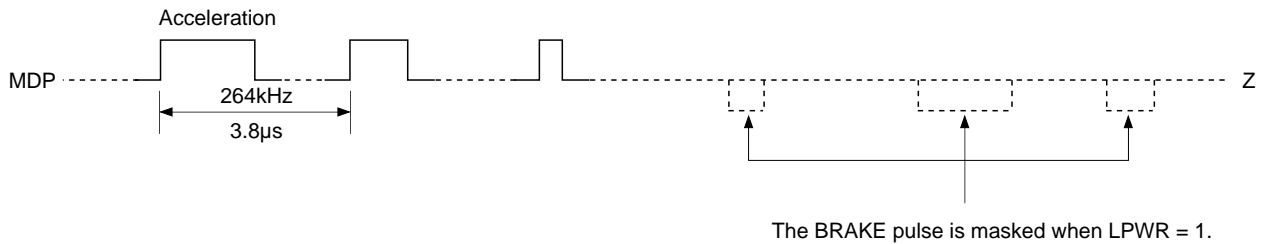

**Timing Chart 2-14**

**CAV-W mode** EPWM = 1, DCLV PWM MD = LPWR = 0

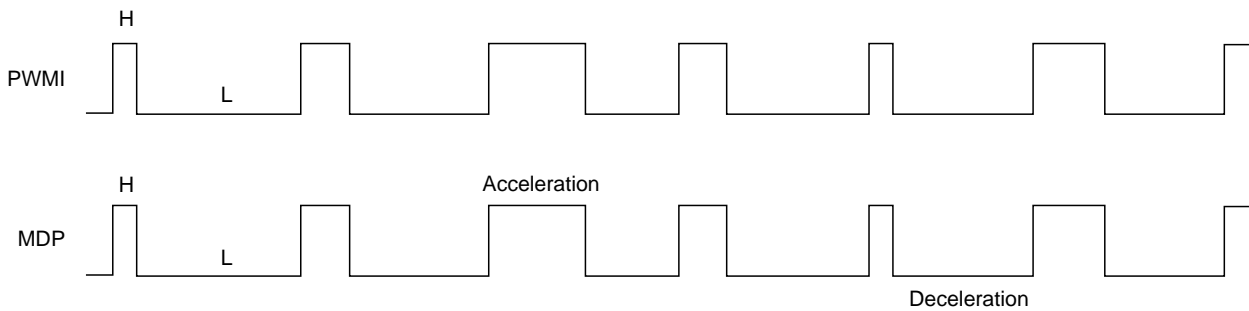

**Timing Chart 2-15**

**CAV-W mode** EPWM = 1, DCLV PWM MD = 0, LPWR = 1

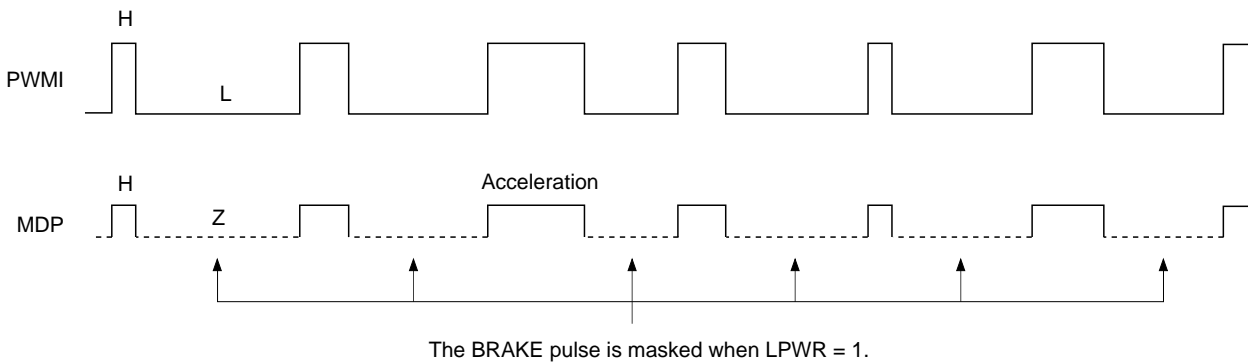

**Note)** CLV-W and CAV-W modes support control only by the ternary output of the MDP pin. Therefore, set DCLV PWM MD to 0 in CLV-W and CAV-W modes.

## 2-2. Subcode Interface

There are two methods for reading out a subcode externally.

The 8-bit subcodes P to W can be read out from SBSO by inputting EXCK to the CXD2548R.

Sub Q can be read out after checking CRC of the 80 bits in the subcode frame.

Sub Q can be read out from the SQSO pin by inputting 80 clock pulses to the SQCK pin when SCOR comes correctly and CRCF is high.

### P to W Subcode Readout

Data can be read out by inputting EXCK immediately after WFCK falls. (See Timing Chart 2-16.)

### 80-bit Sub Q Readout

Fig. 2-2 shows the peripheral block of the 80-bit Sub Q register.

- First, Sub Q, regenerated at one bit per frame, is input to the 80-bit serial/parallel register and the CRC check circuit.

- 96-bit Sub Q is input, and if the CRC is OK, it is output to SQSO with CRCF = 1. In addition, 80 bits are loaded into the parallel/serial register.

When SQSO goes high 400 $\mu$ s (monostable multivibrator time constant) or more after subcode readout, the CPU determines that new data (which passed the CRC check) has been loaded.

- When the 80-bit data is loaded, the order of the MSB and LSB is inverted within each byte. As a result, although the sequence of the bytes is the same, the bits within the bytes are now ordered LSB first.
- Once the 80-bit data load is confirmed, SQCK is input so that the data can be read.

The SQCK input is detected, and the retriggerable monostable multivibrator is reset while the input is low.

- The retriggerable monostable multivibrator has a time constant from 270 to 400 $\mu$ s. When the duration when SQCK is high is less than this time constant, the monostable multivibrator is kept reset; during this interval, the serial/parallel register is not loaded into the parallel/serial register.
- While the monostable multivibrator is being reset, data cannot be loaded in the 80-bit parallel/serial register. In other words, while reading out with a clock cycle shorter than this time constant, the register will not be rewritten by CRCOK and others.
- See Timing Chart 2-17.
- The high and low intervals for SQCK should be between 750ns and 120 $\mu$ s.

Timing Chart 2-16

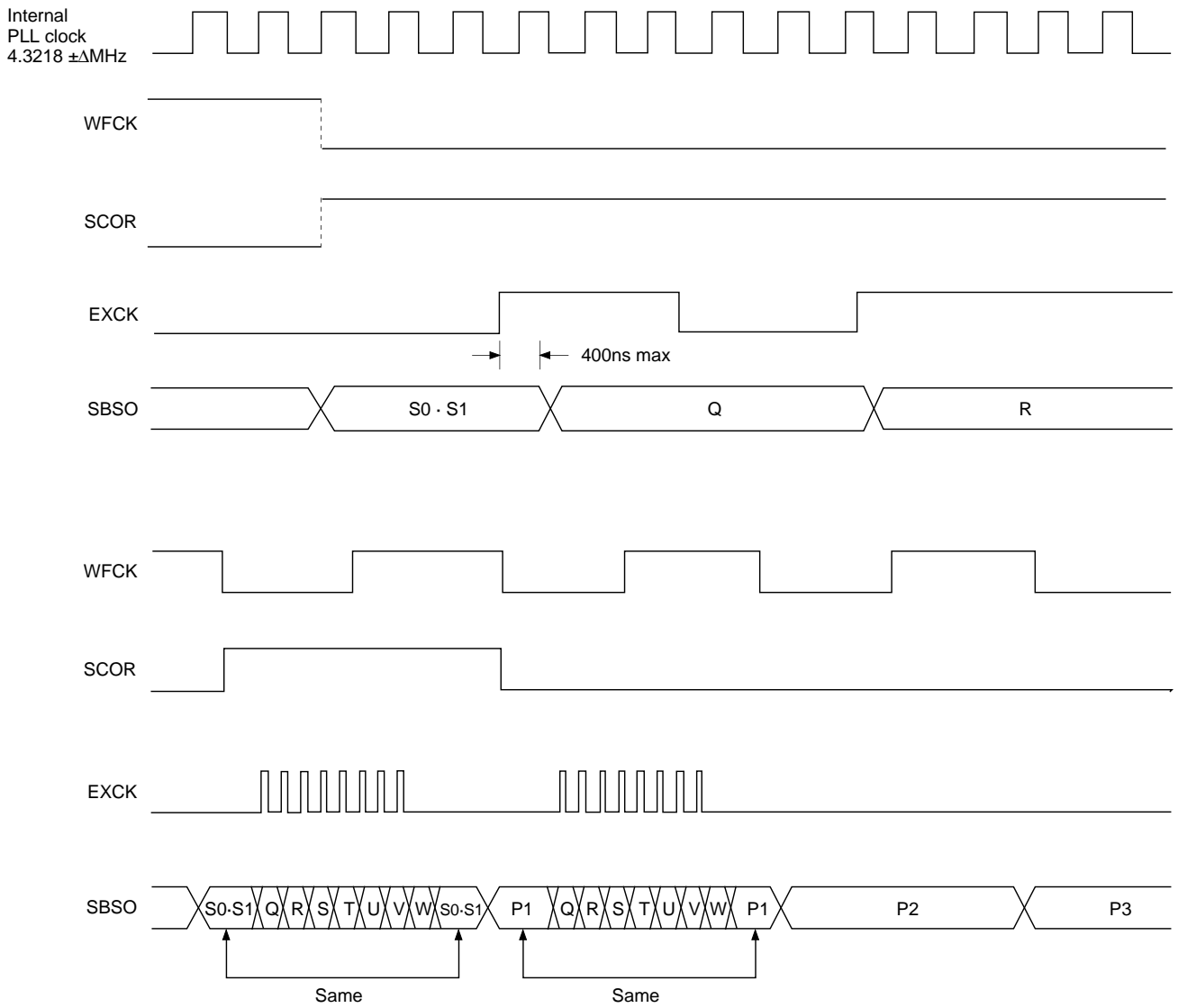

Sub Code P.Q.R.S.T.U.V.W Read Timing

Fig. 2-2 Block Diagram

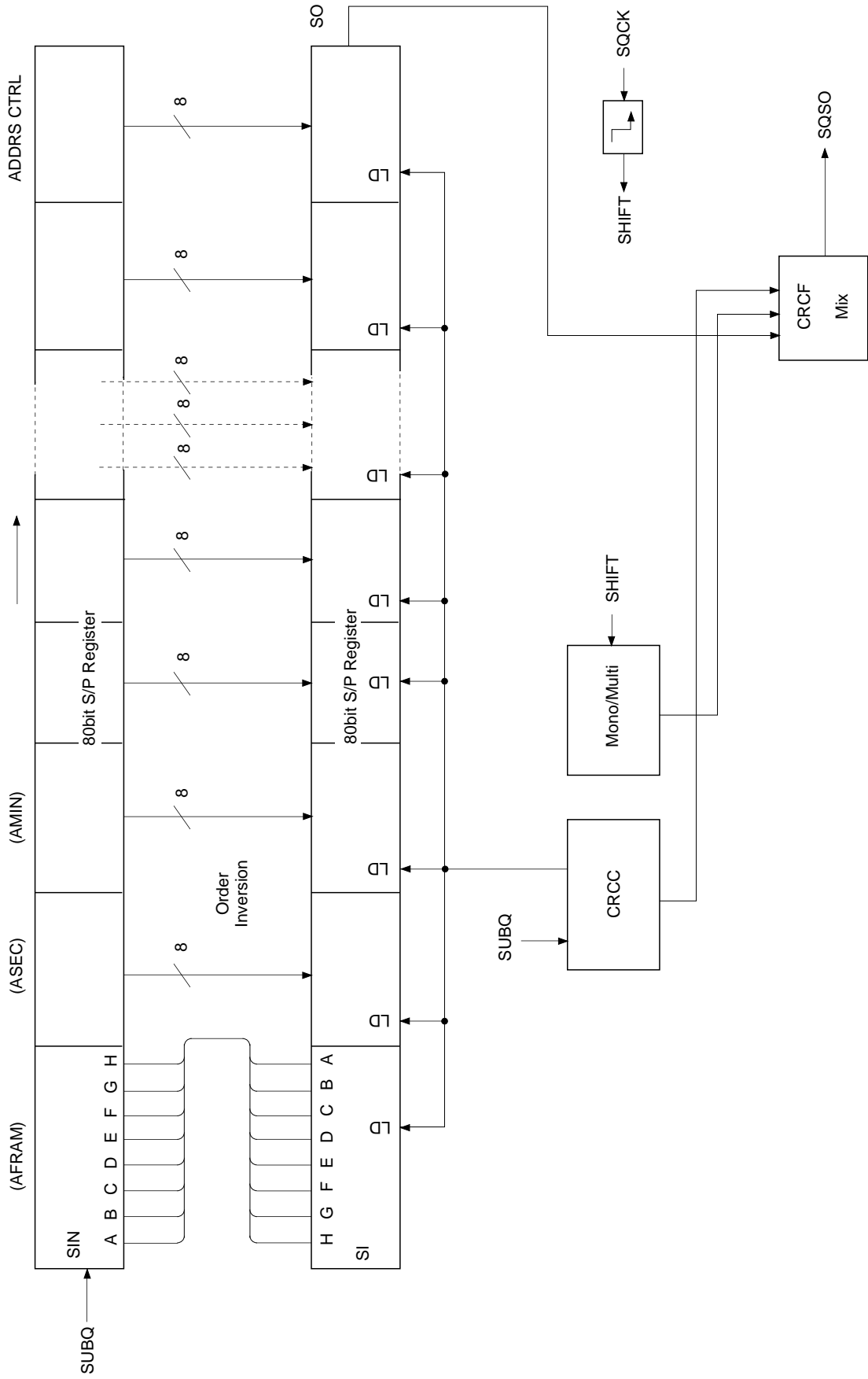

Timing Chart 2-17

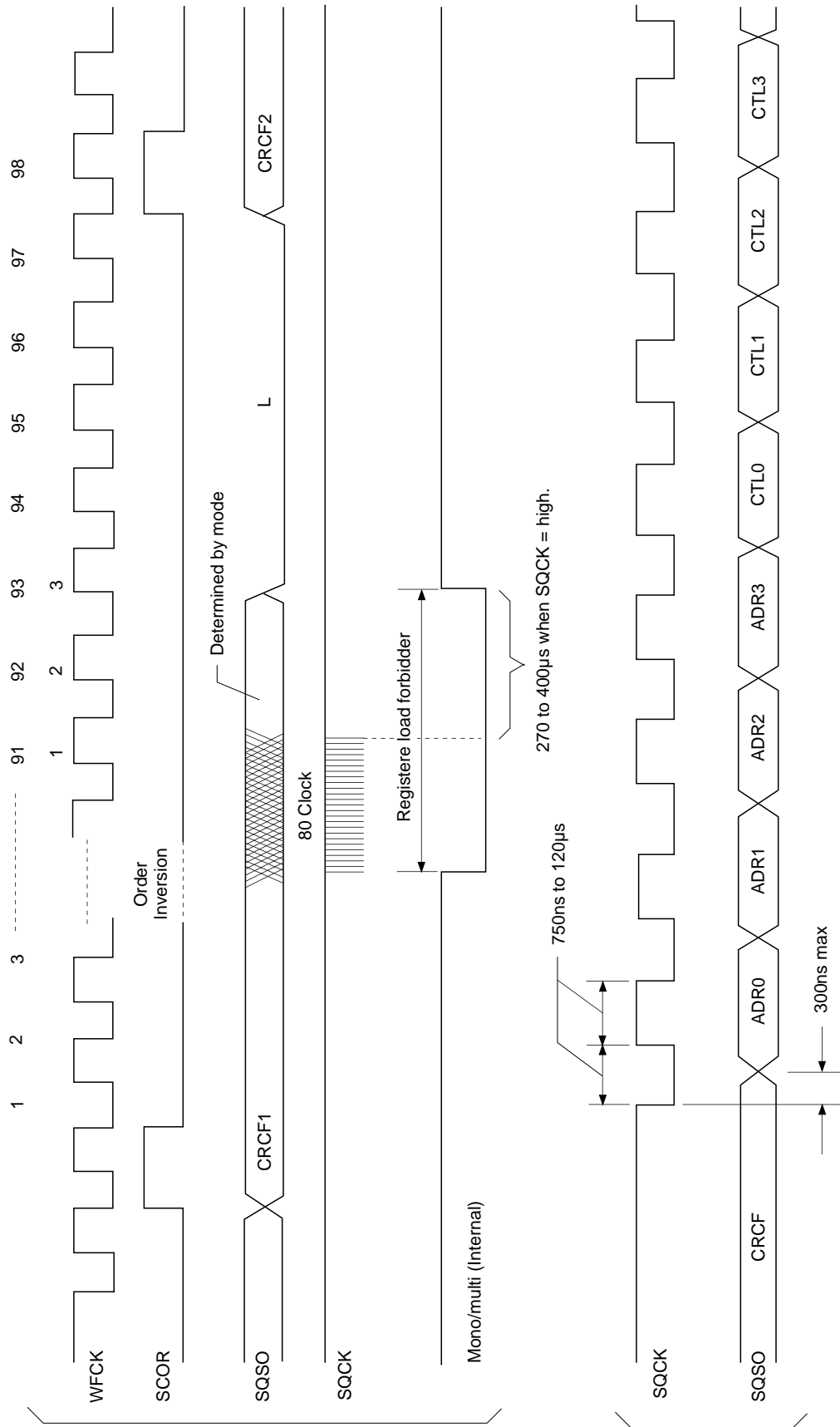

Timing Chart 2-18

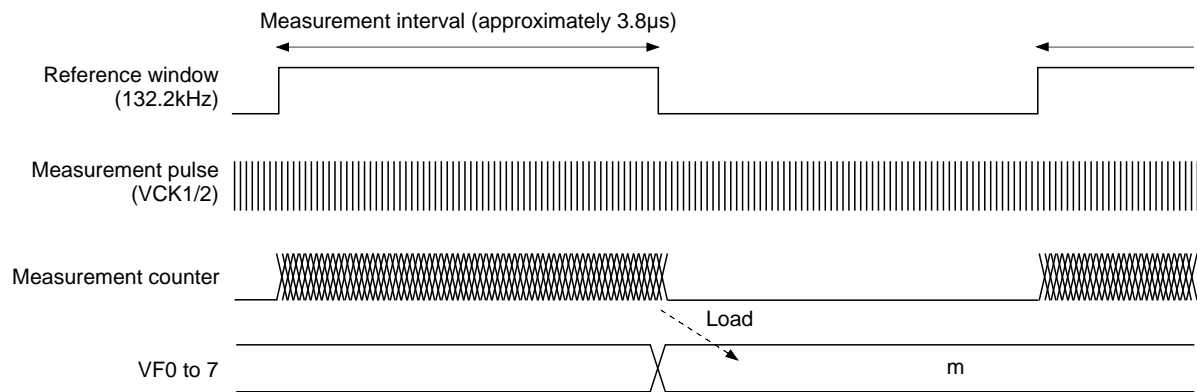

The relative velocity of the disc can be obtained with the following equation.

$$R = \frac{m + 1}{32} \text{ (R: Relative velocity, m: Measurement results)}$$

VF0 to 7 is the result obtained by counting VCKI/2 pulses while the reference signal (132.2kHz) generated from the crystal (384Fs) is high. This count is 31 when the disc is rotating at normal speed and 63 when it is rotating at double speed (when DSPB is low).

### [3] Description of Other CD Signal Processing and DAC System Functions

#### 3-1. Description of DSP Operating Modes

This LSI has three basic operating modes using a combination of spindle control and the PLL. The operations for each mode are described below.

##### (a) CLV-N Mode

This mode is compatible with the CXD2507AQ, and operation is the same as for the conventional control. The PLL capture range is  $\pm 150\text{kHz}$ .

##### (b) CLV-W Mode

This is the wide capture range mode. This mode allows PLL to follow the rotational velocity of the disc. This rotational following control has two types: using the built-in VCO2 or providing an external VCO. The spindle is the same CLV servo as for the conventional series. Operation using the built-in VCO2 is described below. (When using an external VCO, input the signal from the VPCO1 pin to the low-pass filter, use the output from the low-pass filter as the control voltage for the external VCO, and input the oscillation from the VCO to the VCKI pin.) While starting to rotate a disc and/or speeding up to the lock range from the condition that a disc stops, CAV-W mode should be used. Concretely saying, firstly send  $\$E665$  to set CAV-W mode and kick a disc, secondly send  $\$E60C$  to set CLV-W mode if ALOCK is high, which can be read out serially from the SQSO pin. CLV-W mode can be used while ALOCK is high. The microcomputer monitors the serial data output, and must return the operation to the speed adjusting state (CAV-W mode) when ALOCK becomes low. The control flow according to the microcomputer software in CLV-W mode is shown in Fig. 3-2.

In CLV-W mode (normal), low power consumption is achieved by setting LPWR to high. Control was formerly performed by applying acceleration and deceleration pulses to the spindle motor. However, when LPWR is set to high, deceleration pulses are not output, thereby achieving low power consumption mode.

CLV-W mode supports control only by the ternary output of the MDP pin. Therefore, when using CLV-W mode, set DCLV PWM MD to low.

**Note)** The capture range for this mode is theoretically up to the signal processing limit.

##### (c) CAV-W Mode

This is CAV mode. In this mode the external clock is fixed and it is possible to control spindle to variable rotational velocity. The rotational velocity is determined by the VP0 to 7 setting values or the external PWM. When controlling the spindle with VP0 to 7, setting CAV-W mode with  $\$E665$  command and controlling VP0 to 7 with the  $\$DX$  commands allows the rotational velocity to be varied from low speed to double speed. (See " $\$DX$  Commands".) Also, when controlling the spindle with the external PWM, the PWMI pin is binary input which becomes KICK during high intervals and BRAKE during low intervals.

The microcomputer can know the rotational velocity using V16M. And the reference for the velocity measurement is a signal of  $132.3\text{kHz}$  obtained by  $1/128$  of the crystal ( $384\text{Fs}$ ). The velocity is obtained by counting  $V16M/2$  pulses while the reference is high, and the result is output from the new CPU interface as 8 bits (VP0 to 7). These measurement results are 31 when the disc is rotating at normal speed or 63 when it is rotating at double speed. These values match those of the  $256 - n$  for control with VP0 to 7.

In CAV-W mode, the spindle is set to the desired rotational velocity and the operation speed for the entire system follows this rotational velocity. Therefore, the cycles for the  $F_s$  system clock, PCM data and all other output signals from this LSI change according to the rotational velocity of the disc (excluding the servo output block).

**Note)** The capture range for this mode is theoretically up to the signal processing limit.

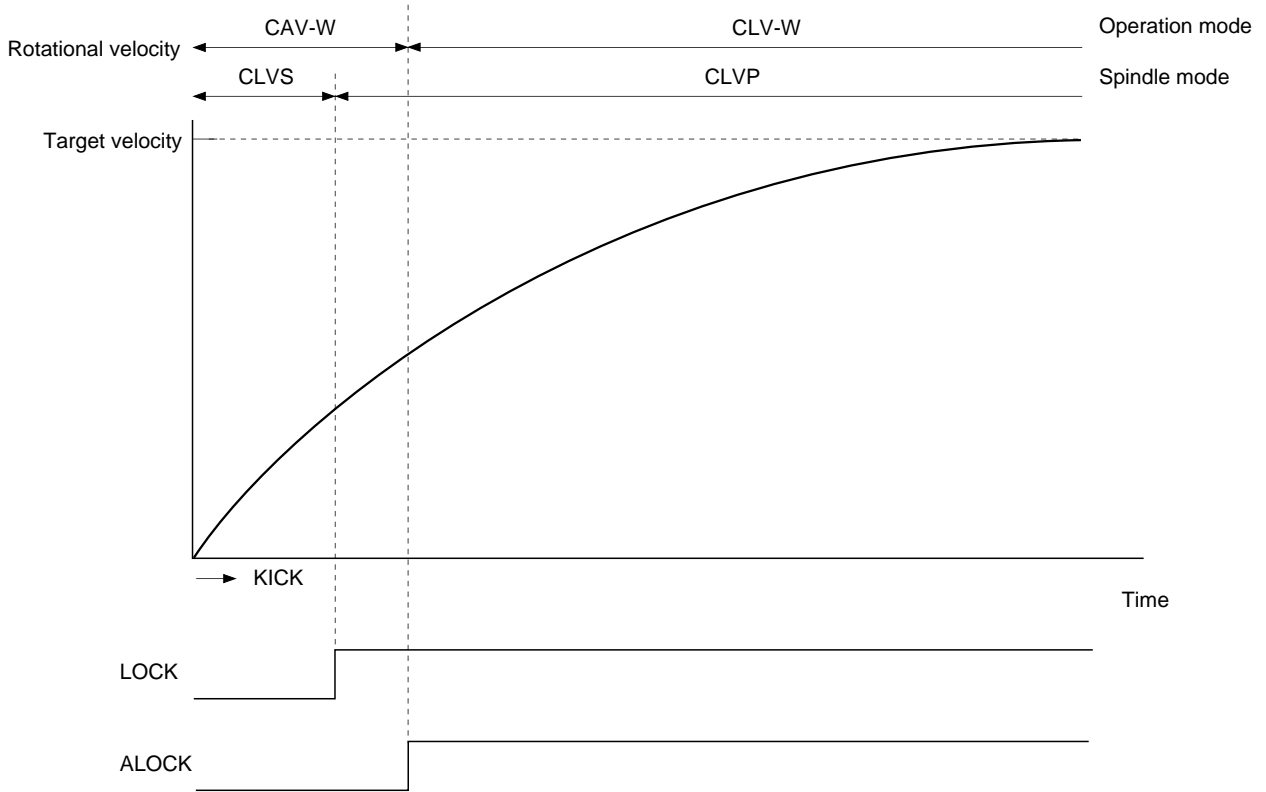

Fig. 3-1. Disc Stop to Regular Playback in CLV-W Mode

CLV-W Mode

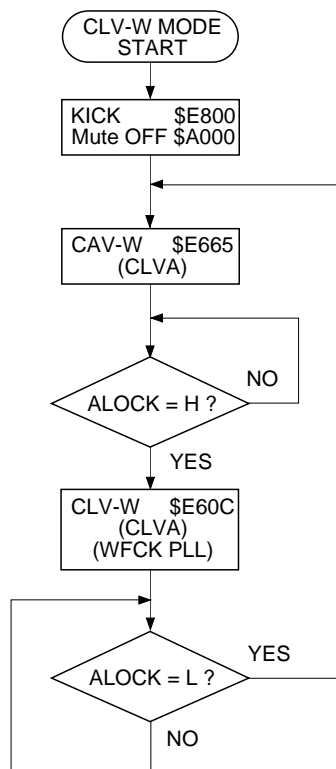

Fig. 3-2. CLV-W Mode Flow Chart

### 3-2. Frame Sync Protection

- In normal-speed playback, a frame sync is recorded approximately every 136 $\mu$ s (7.35kHz). This signal is used as a reference to recognize the data within a frame. Conversely, if the frame sync cannot be recognized, the data is processed as error data because the data cannot be recognized. As a result, recognizing the frame sync properly is extremely important for improving playability.
- In the CXD2548R, window protection and forward protection/backward protection have been adopted for frame sync protection. These functions achieve very powerful frame sync protection. There are two window widths: one for cases where a rotational disturbance affects the player and the other for cases where there is no rotational disturbance (WSEL = 0/1). In addition, the forward protection counter is fixed to 13, and the backward protection counter to 3. Concretely, when the frame sync is being played back normally and then cannot be detected due to scratches, a maximum of 13 frames are inserted. If frame sync cannot be detected for 13 frames or more, the window opens to resynchronize the frame sync. In addition, immediately after the window opens and the resynchronization is executed, if a proper frame sync cannot be detected within 3 frames, the window opens immediately.

### 3-3. Error Correction

- In the CD format, one 8-bit data contains two error correction codes, C1 and C2. For C1 correction, the code is created with 28-byte information and 4-byte C1 parity. For C2 correction, the code is created with 24-byte information and 4-byte C2 parity. Both C1 and C2 are Reed Solomon codes with a minimum distance of 5.
- The CXD2548R's SEC strategy uses powerful frame sync protection and C1 and C2 error correction to achieve high playability.
- The correction status can be monitored externally. See Table 3-1.
- When the C2 pointer is high, the data in question was uncorrectable. Either the pre-value was held or an average value interpolation was made for the data.

MNT3	MNT1	MNT0	Description
0	0	0	No C1 errors
0	0	1	One C1 error corrected
0	1	1	C1 correction impossible
1	0	0	No C2 errors
1	0	1	One C2 error corrected
1	1	1	C2 correction impossible

**Table 3-1.**

Timing Chart 3-1

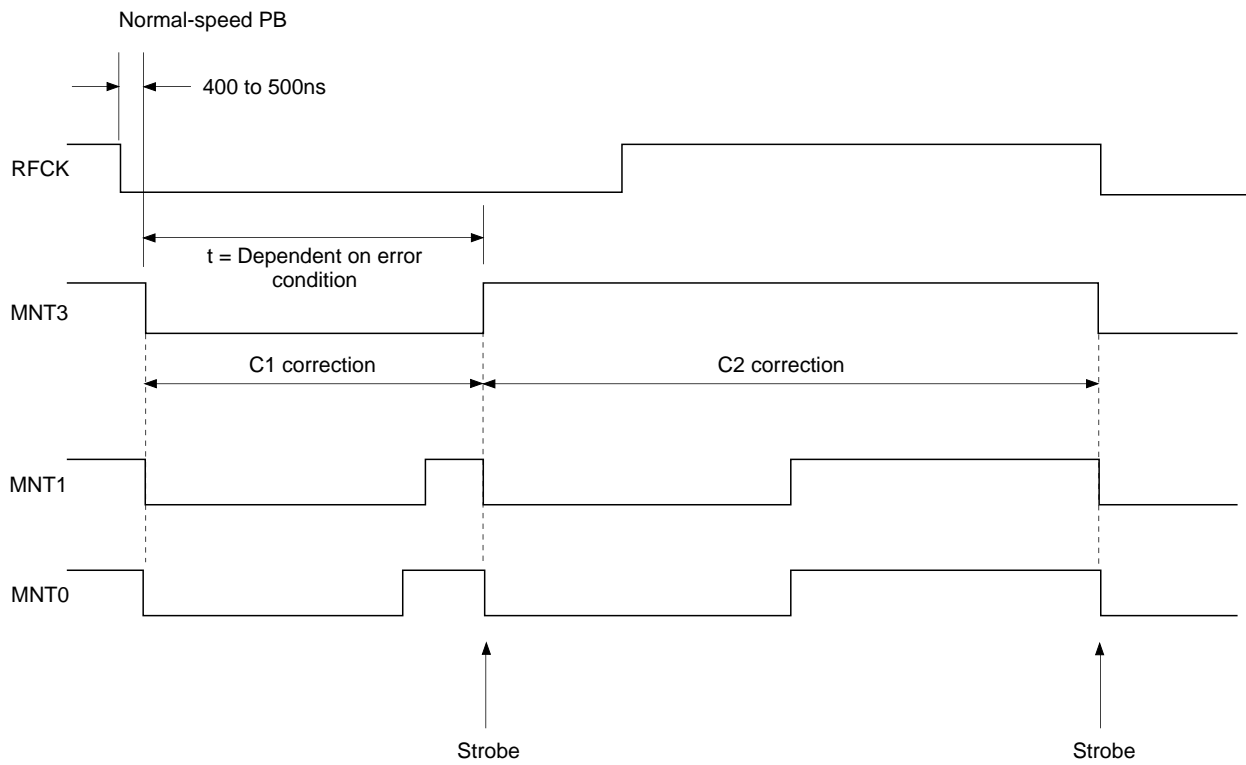

**3-4. DA Interface**

- The CXD2548R's DA interface is as follows.

This interface includes 48 cycles of the bit clock within one LRCK cycle, and is MSB first. When LRCK is high, the data is for the left channel.

Timing Chart 3-2

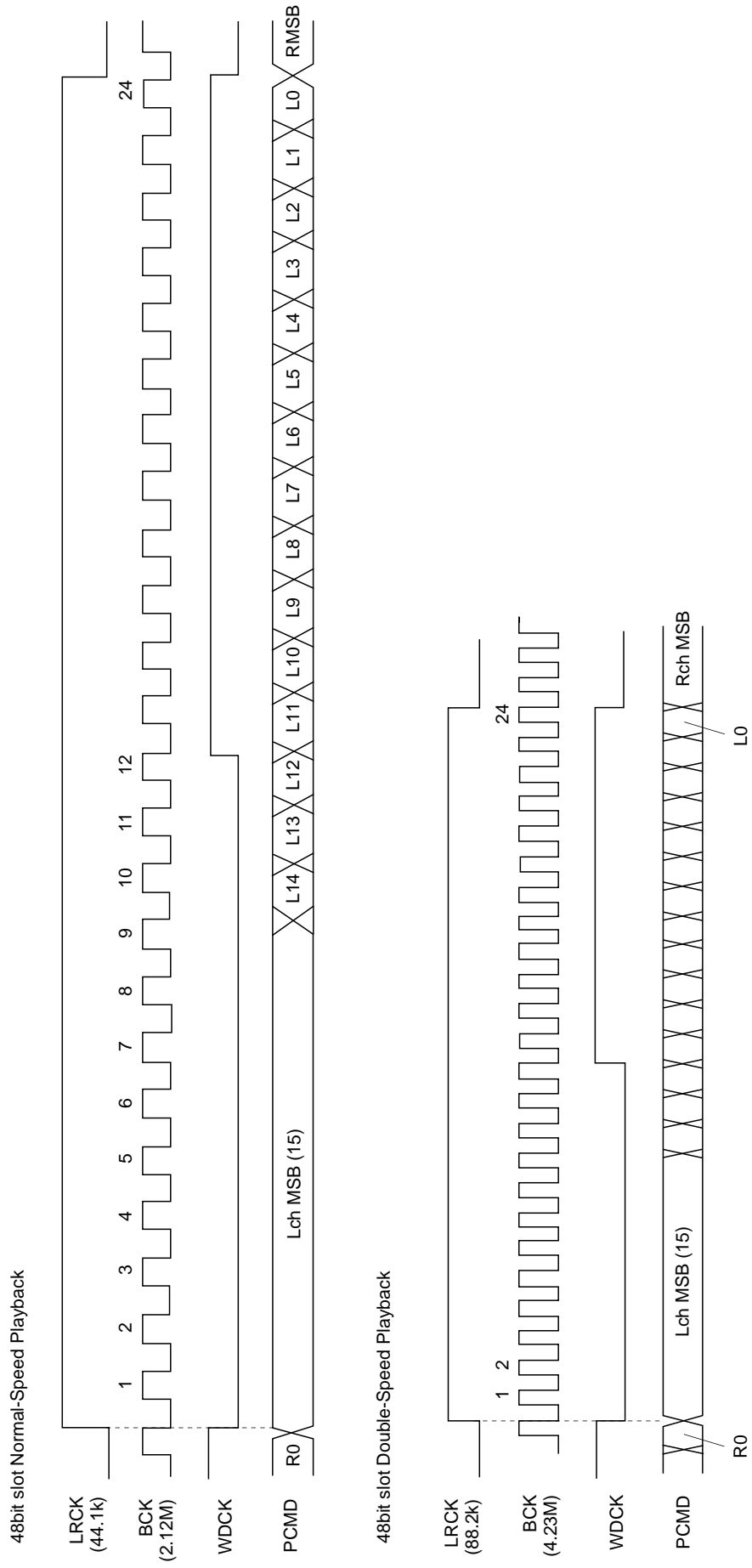

**4-5. Digital Out**

There are three Digital Out: the type 1 format for broadcasting stations, the type 2 form 1 format for home use, and the type 2 form 2 format for the manufacture of software.

The CXD2548R supports type 2 form 1.

Sub Q data which are matched twice in succession after a CRC check are input to the first four bits (bits 0 to 3) of the channel status.

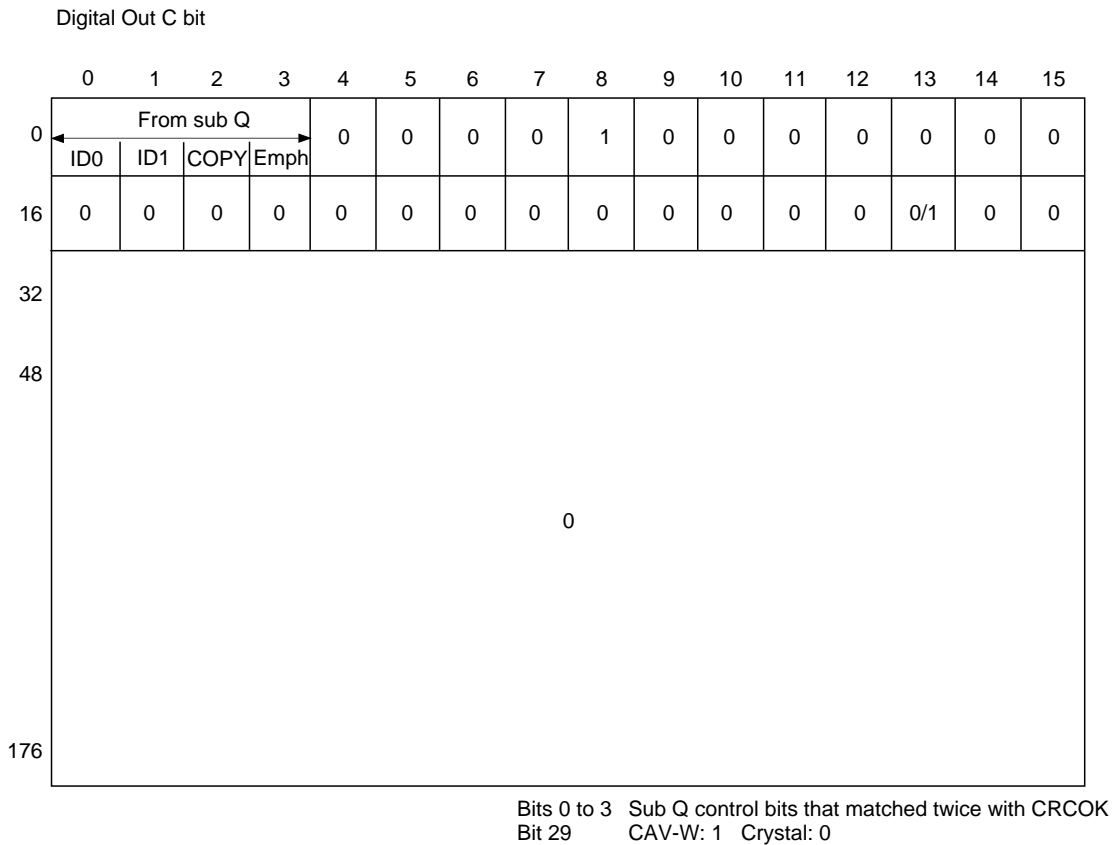

**Table 3-2.**

**3-6. Servo Auto Sequence**

This function performs a series of controls, including auto focus and track jumps. When the auto sequence command is received from the CPU, auto focus, 1-track jump, 2N-track jump and N-track move are executed automatically.

Servo is used in an exclusive manner during the auto sequence execution (when XBUSY = low), so that commands from the CPU are not transferred to the servo, but can be sent to the CXD2548R.

Connect the CPU and RF as shown in Fig. 3-3.

When CLOK goes from low to high while XBUSY is low, XBUSY does not become high for a maximum of 100µs after that point. This is to prevent the transfer of erroneous data to the servo when XBUSY changes from low to high by the monostable multivibrator, which is reset by CLOK being low (when XBUSY is low).

(a) Auto focus (\$47)

Focus search-up is performed, FOK and FZC are checked, and the focus servo is turned on.

If \$47 is received from the CPU, the focus servo is turned on according to Fig. 3-4. The auto focus starts with focus search-up, and note that the pickup should be lowered beforehand (focus search down). In addition, blind E of register 5 is used to eliminate FZC chattering. Concretely, the focus servo is turned on at the falling edge of FZC after FZC has been continuously high for a longer time than E.

**CXD2548R connection diagram when using auto sequence (example)**

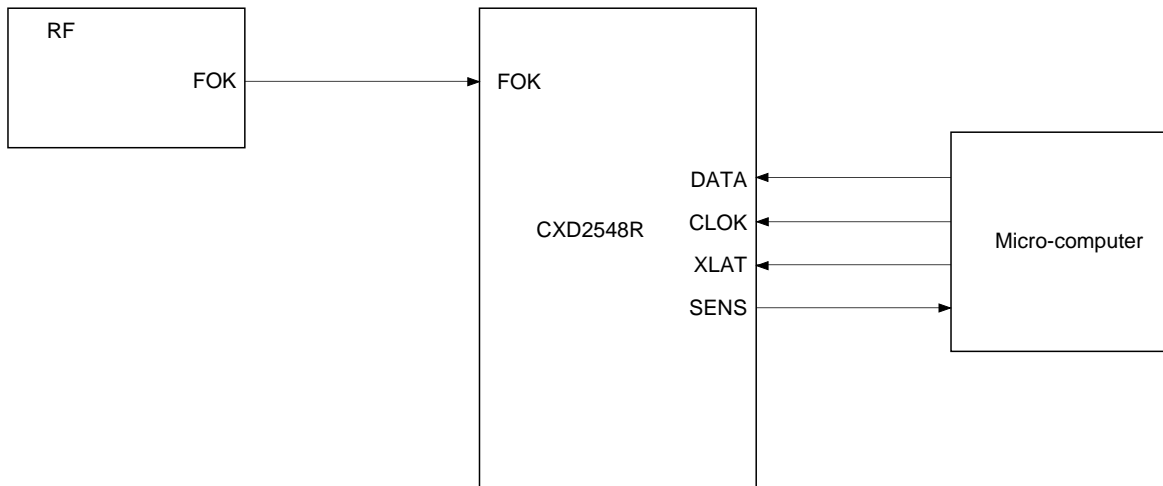

**Fig. 3-3**

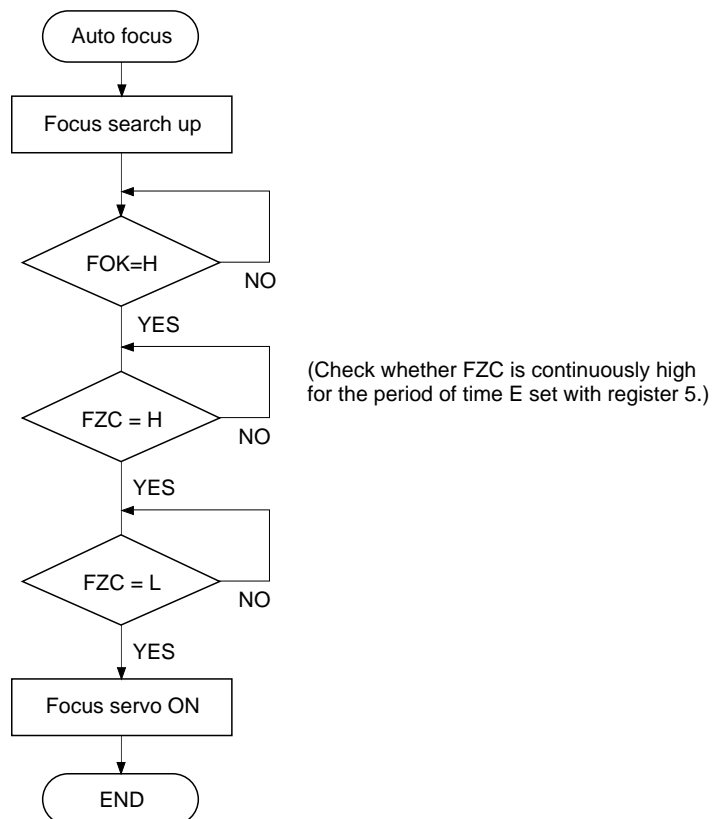

**Fig. 3-4-(a). Auto Focus Flow Chart**

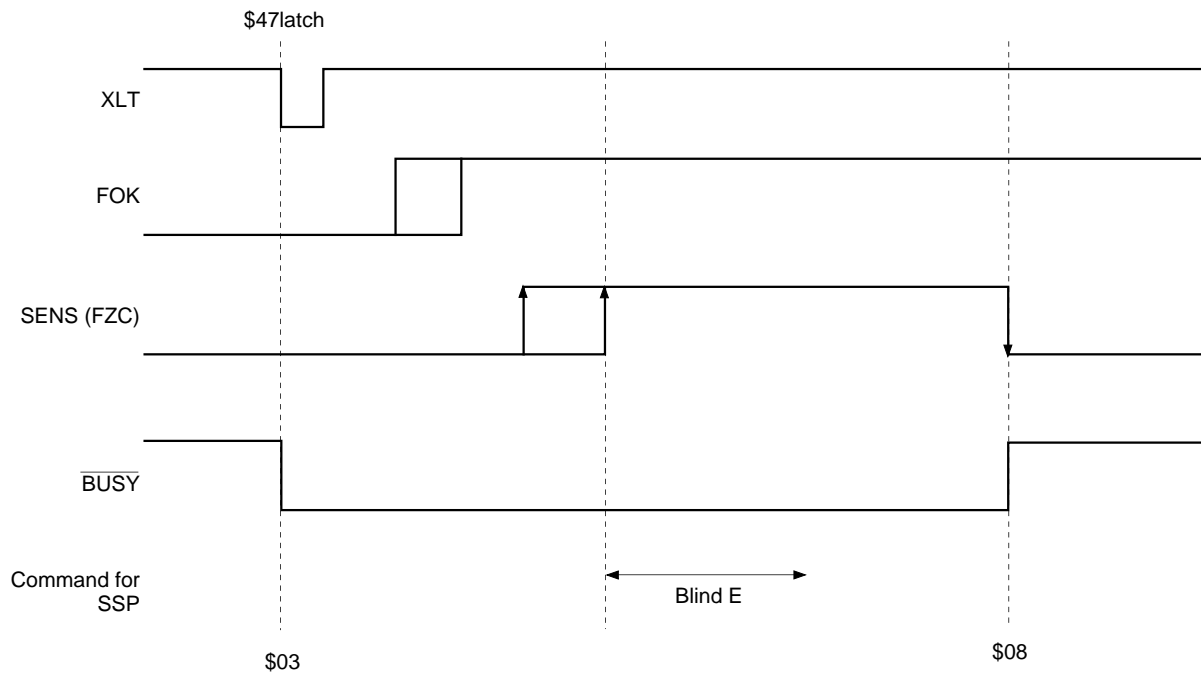

**Fig. 3-4-(b). Auto Focus Timing Chart**

(b) Track jump

1, 10 and 2N-track jumps are performed respectively. Always use this when the focus, tracking, and sled servos are on. Note that tracking gain-up and braking-on should be sent beforehand because they are not involved in this sequence.

- 1-track jump

When \$48 (\$49 for REV) is received from the CPU, a FWD (REV) 1-track jump is performed in accordance with Fig. 3-5. Set blind A and brake B with register 5.

- 10-track jump

When \$4A (\$4B for REV) is received from the CPU, a FWD (REV) 10-track jump is performed in accordance with Fig. 3-6. The principal difference from the 1-track jump is to kick the sled. In addition, after kicking the actuator, when 5 tracks have been counted through COUT, the brake is applied to the actuator. Then, when the actuator speed is found to have slowed up enough (determined by the COUT cycle becoming longer than the overflow C set with register 5), the tracking and sled servos are turned on.

- 2N-track jump

When \$4C (\$4D for REV) is received from the CPU, a FWD (REV) 2N-track jump is performed in accordance with Fig. 3-7. The track jump count N is set with register 7. Although N can be set to  $2^{16}$  tracks, note that the setting is actually limited by the actuator. COUT is used for counting the number of jumps.

Although the 2N-track jump basically follows the same sequence as the 10-track jump, the one difference is that after the tracking servo is turned on, the sled continues to move only for "D", set with register 6.

- N-track move

When \$4E (\$4F for REV) is received from the CPU, a FWD (REV) N-track move is performed in accordance with Fig. 3-8. N can be set to  $2^{16}$  tracks. COUT is used for counting the number of jumps. The N-track move is executed only by moving the sled, and is therefore suited for moving across several thousand to several ten-thousand tracks.

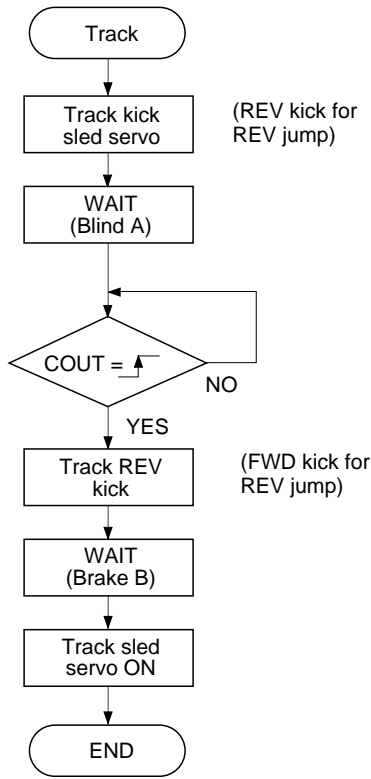

Fig. 3-5-(a). 1-Track Jump Flow Chart

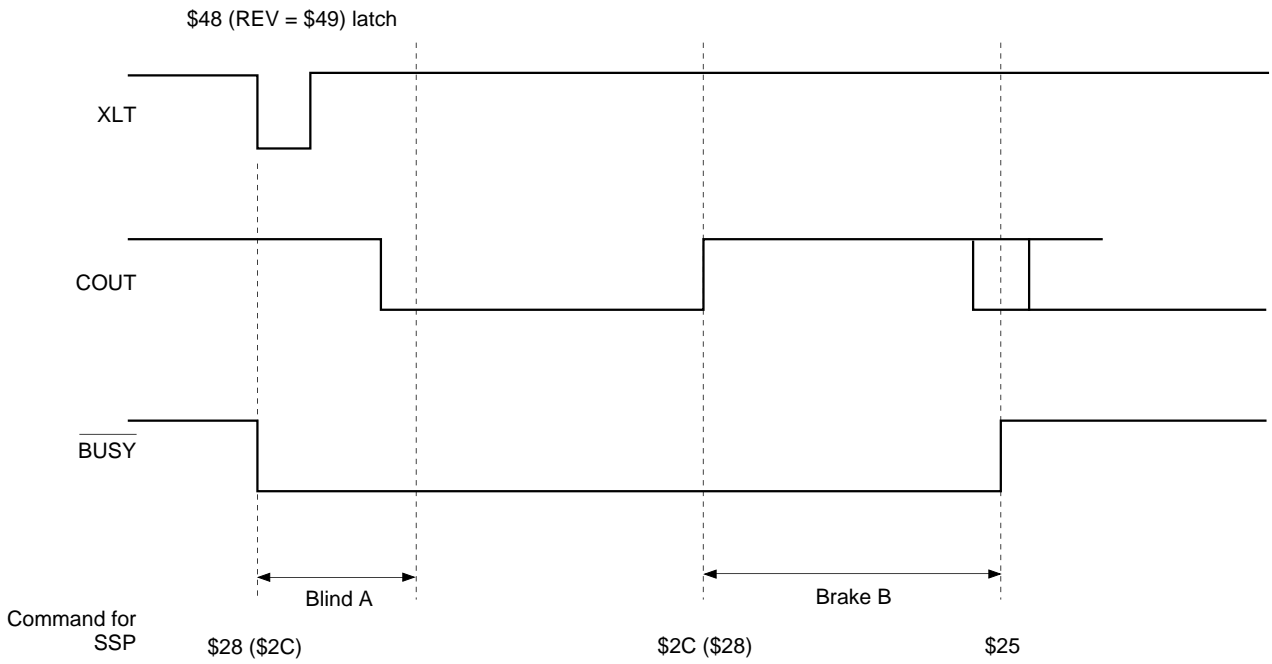

Fig. 3-5-(b). 1-Track Jump Timing Chart

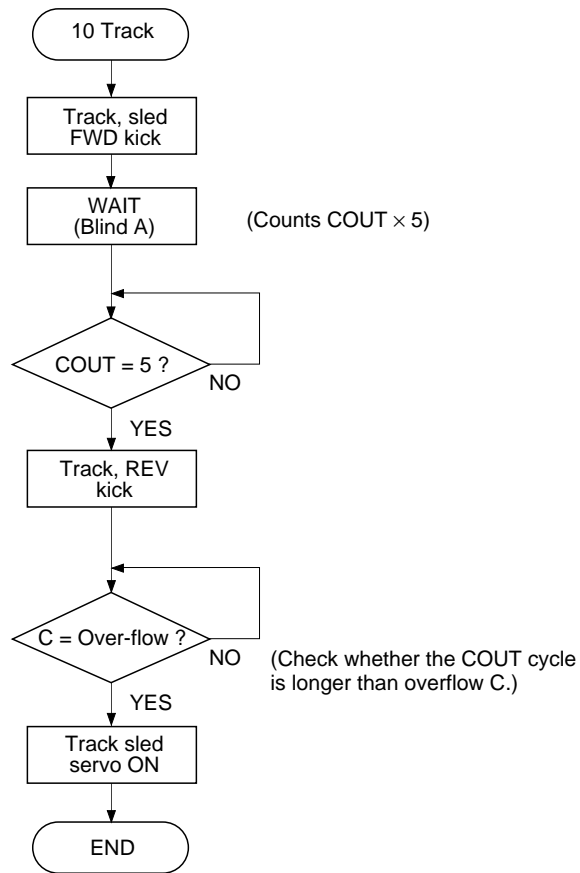

Fig. 3-6-(a). 10-Track Jump Flow Chart

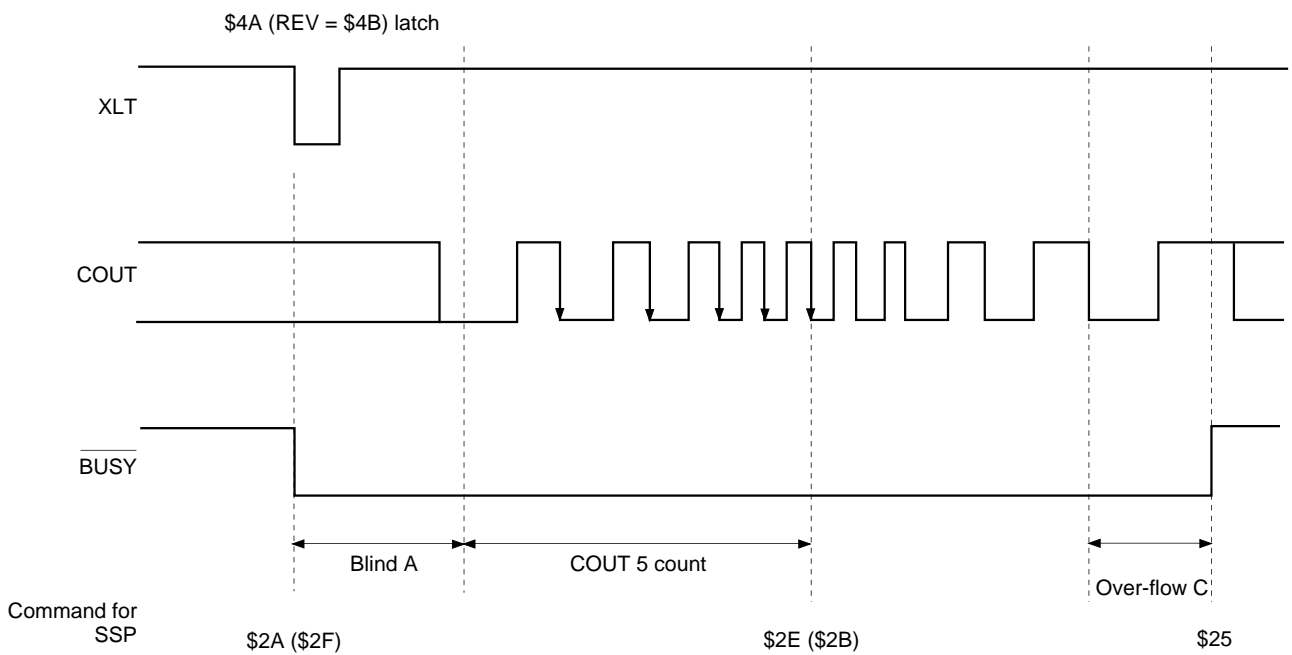

Fig. 3-6-(b). 10-Track Jump Timing Chart

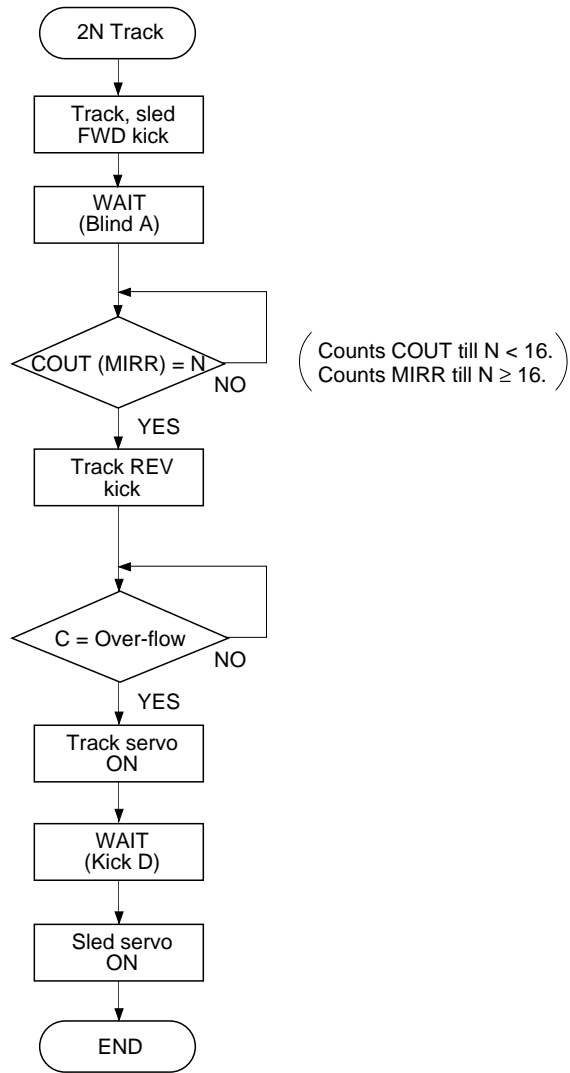

Fig. 3-7-(a). 2N-Track Jump Flow Chart

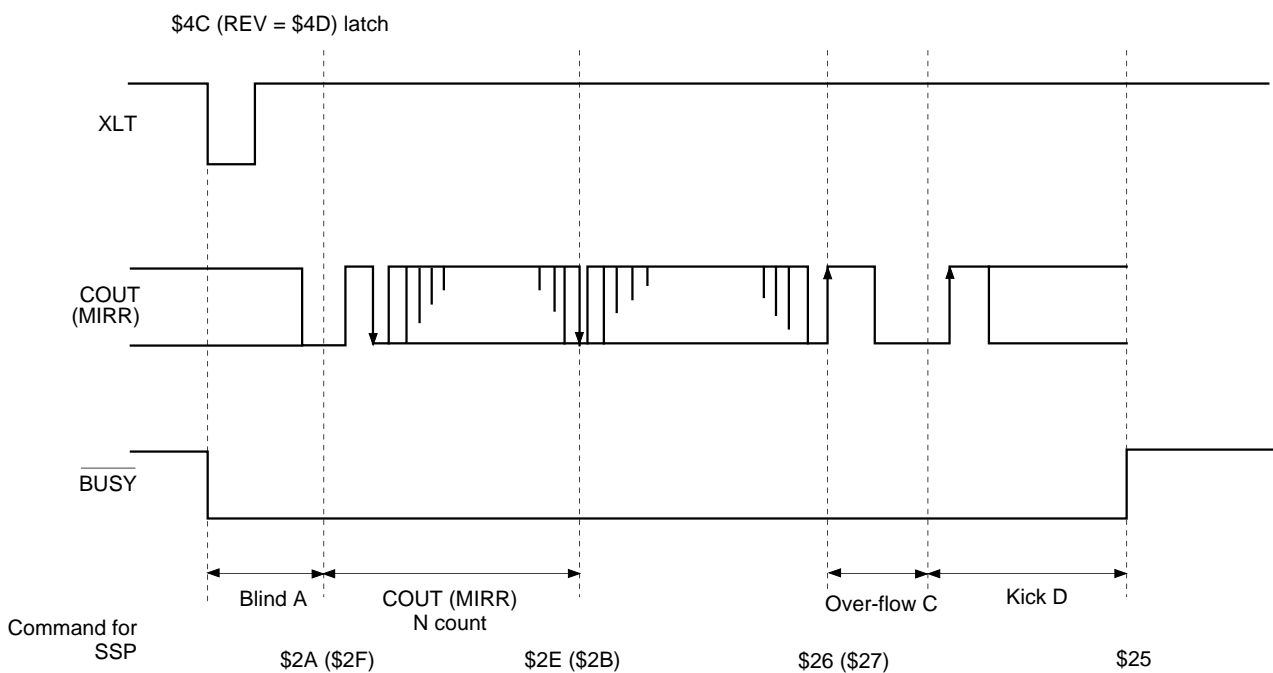

Fig. 3-7-(b). 2N-Track Jump Timing Chart

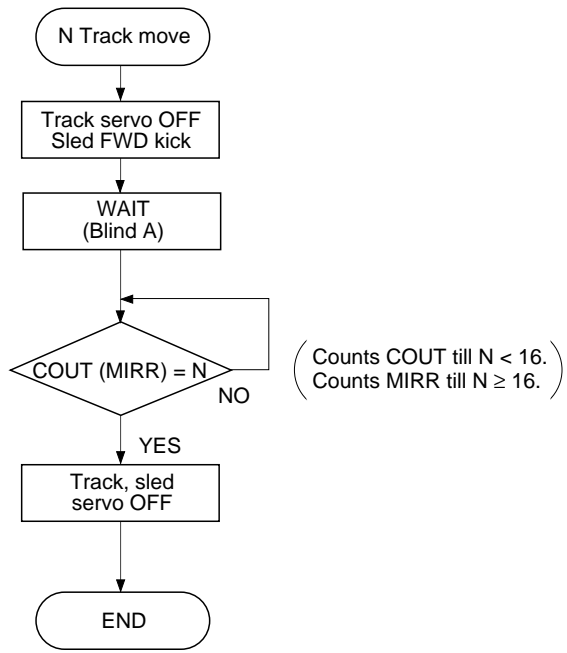

Fig. 3-8-(a). N-Track Move Flow Chart

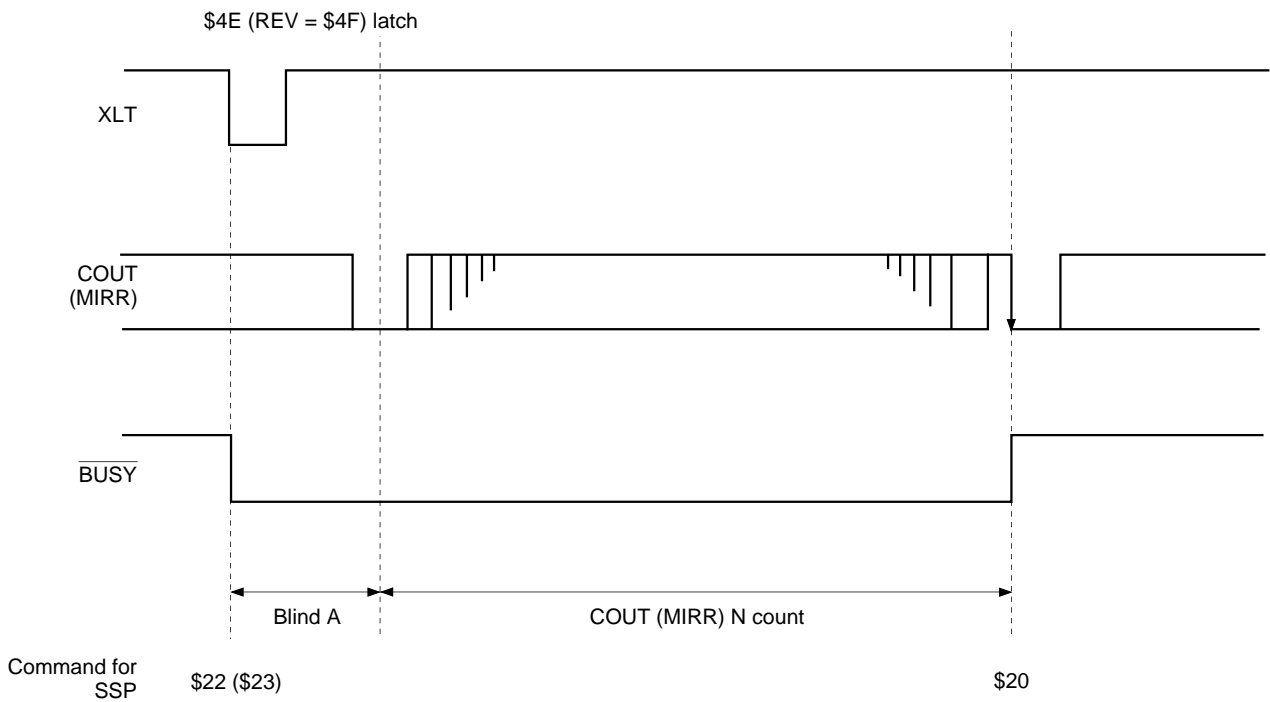

Fig. 3-8-(b). N-Track Move Timing Chart

3-7. Asymmetry Compensation

Fig. 3-9 shows the block diagram and circuit example.

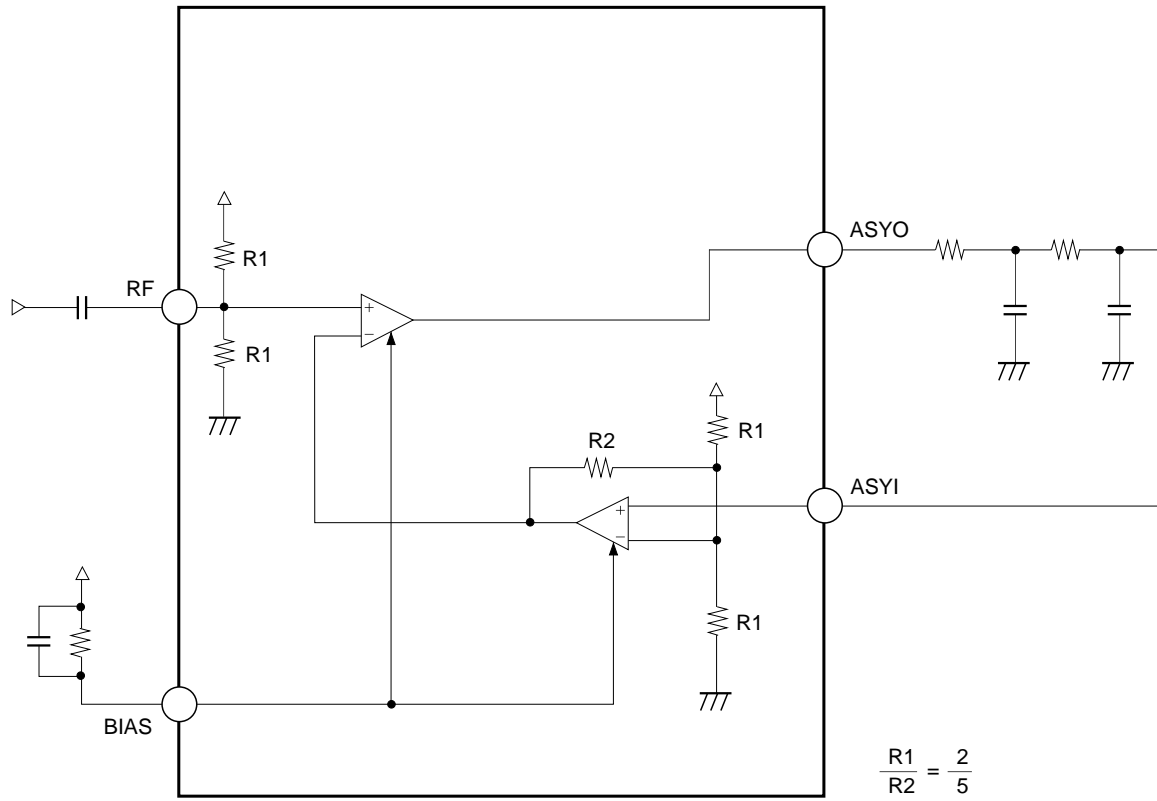

Fig. 3-9. Asymmetry Compensation Application Circuit

### 3-8. Channel Clock Regeneration by the Digital PLL Circuit

- The channel clock is necessary for demodulating the EFM signal regenerated by the optical system. Assuming  $T$  as the channel clock cycle, the EFM signal is modulated in an integer multiple of  $T$  from  $3T$  to  $11T$ . In order to read the information in the EFM signal, this integer value must be read correctly. As a result,  $T$ , that is the channel clock, is necessary.  
In an actual player, a PLL is necessary to regenerate the channel clock because the fluctuation in the spindle rotation alters the width of the EFM signal pulses.

The block diagram of this PLL is shown in Fig. 3-10.

The CXD2548R has a built-in three-stage PLL.

- The first-stage PLL is a wide-band PLL. When using the internal VCO2, an external LPF is necessary; when not using the internal VCO2, external LPF and VCO are necessary.  
The output of this first-stage PLL is used as a reference for all clocks within the LSI.
- The second-stage PLL regenerates the high-frequency clock needed by the third-stage digital PLL.
- The third-stage PLL is a digital PLL that regenerates the actual channel clock.
- A new digital PLL has been provided for CLV-W mode to follow the rotational speed of the disc in addition to the conventional secondary loop.

Block Diagram 3-10

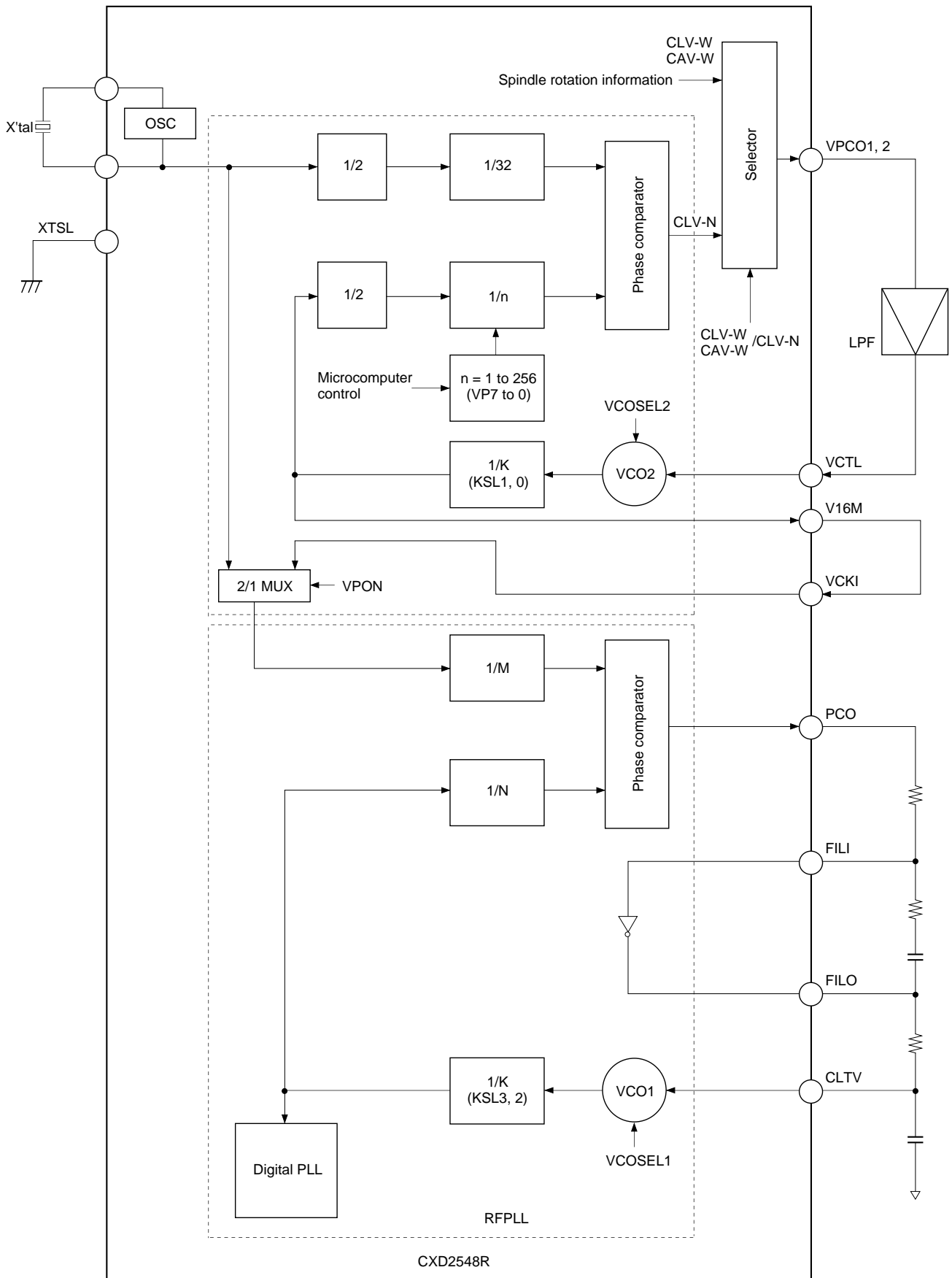

3-9. Digital CLV

Fig. 3-11 shows the block diagram. Digital CLV outputs MDS error and MDP error with PWM, with sampling frequency increased up to 130Hz during normal-speed playback in CLVS, CLVP and other modes.

In addition, the digital spindle servo gain is variable.

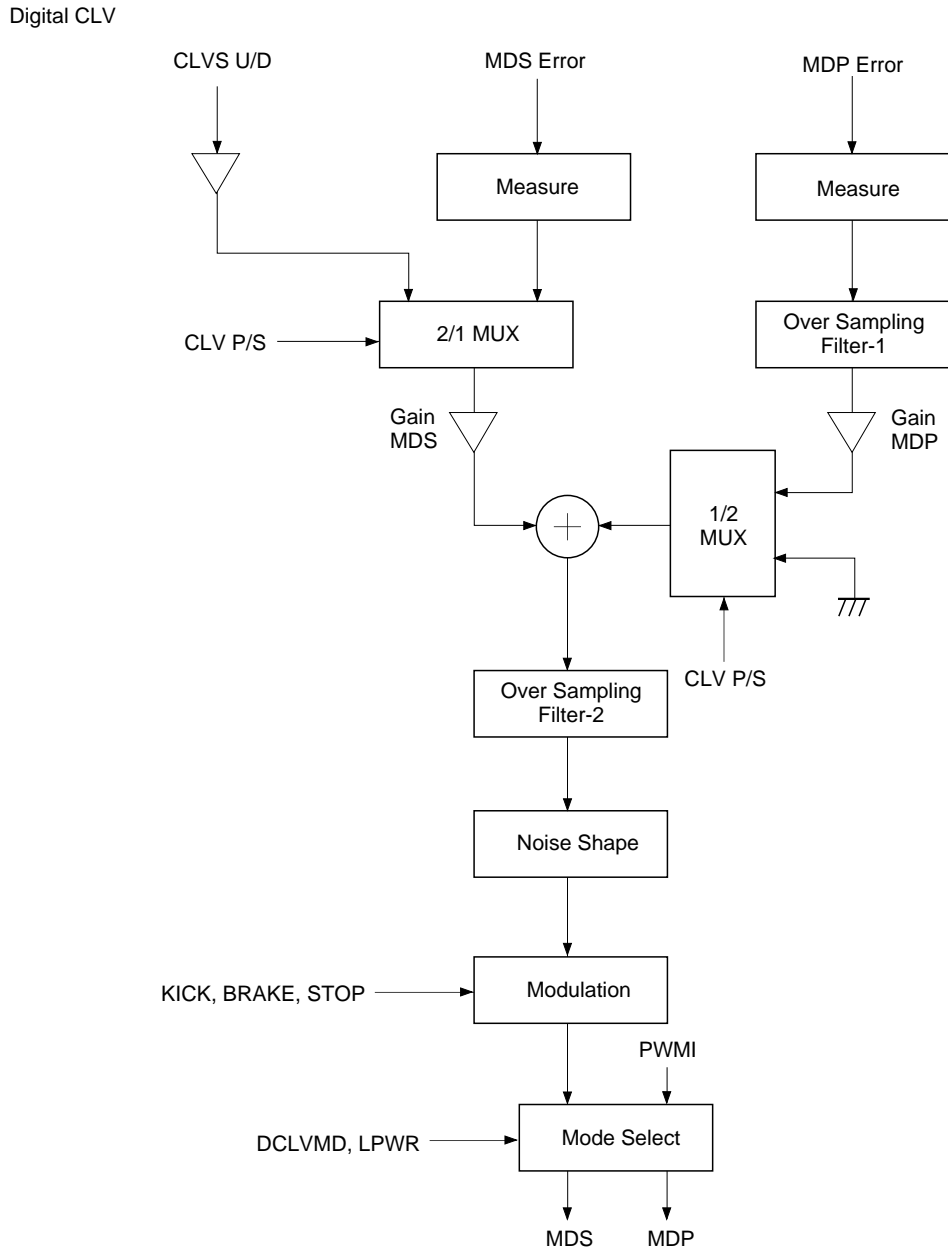

CLVS U/D: Up/down signal from CLVS servo  
 MDS error: Frequency error for CLVP servo  
 MDP error: Phase error for CLVP servo  
 PWMI: Spindle drive signal from the microcomputer

Fig. 3-11. Block Diagram

**3-10. 1-bit DAC Block**

**(a) DAC block input timing**

Timing Chart 3-3 shows the DAC block input timing chart. Audio data is not transferred from the CD signal processor block to the DAC block inside the CXD2548R. This is to allow data to be sent to the DAC block via the audio DSP, etc. When the data is input to the DAC block without using the audio DSP, the data must be connected outside the LSI. In this case, EMPH, LRCK, BCK and PCMD can be connected directly with EMPHI, LRCKI, BCKI and PCMDI.

**(b) Description of DAC block functions**

**Zero data detection**

When the condition where the lower 4 bits of the input data are DC and the remaining upper bits are all "0" or all "1" has continued about for 300ms, zero data is detected. Zero data detection is performed independently for the left and right channels.

**Mute flag output**

The LMUT and RMUT pins go active when any one of the following conditions is met. The polarity can be selected with the ZDPL command of \$9X.

- When zero data is detected
- When a high signal is input to the SYSM pin
- When the SMUT command of \$AX is set

**Attenuation operation**

Assuming attenuation data X1, X2 and X3 ( $X1 > X3 > X2$ ), the corresponding audio outputs are Y1, Y2 and Y3 ( $Y1 > Y3 > Y2$ ). First, X1 is sent, followed by X2. If X2 is sent before X1 reaches Y1 (A in the figure), X1 continues approaching Y2. Next, if X3 is sent before X1 reaches Y2 (B or C in the figure), X1 then approaches Y3 from the value (B or C in the figure) at that point.

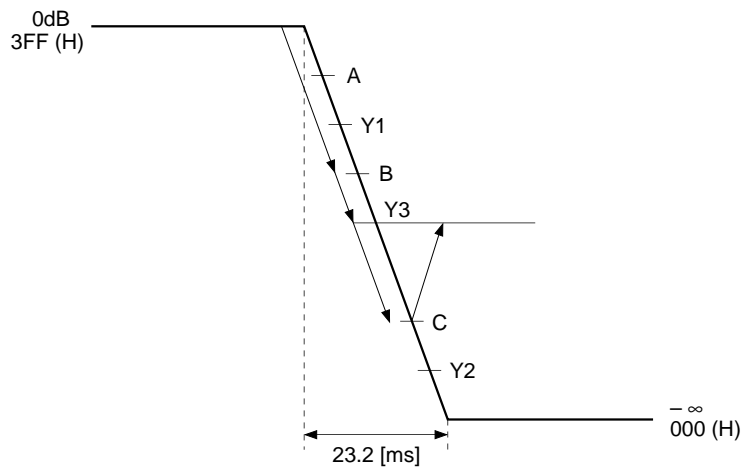

**Soft mute**

When any one of the following conditions is met, soft mute results and the input data is attenuated to "0".

- When attenuation data of 000 (high) is set
- When "Soft mute" in the operation controls for serial control is high
- When a high signal (= mute) is input to the input pin SYSM

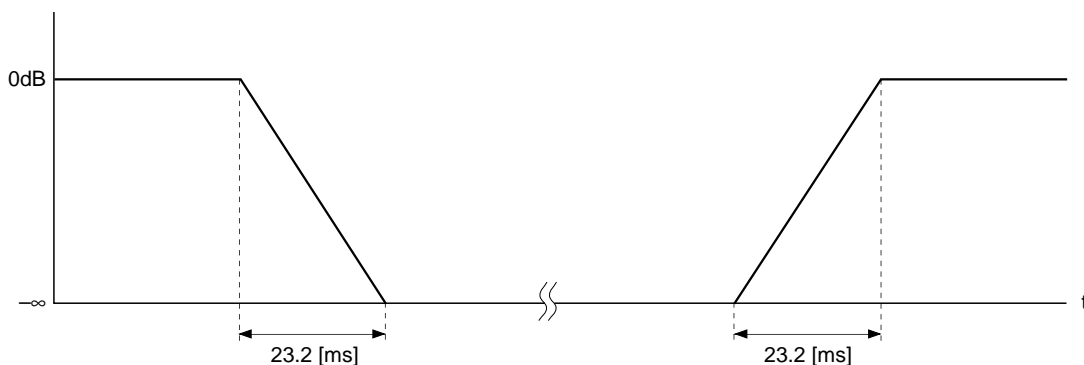

Timing Chart 3-3

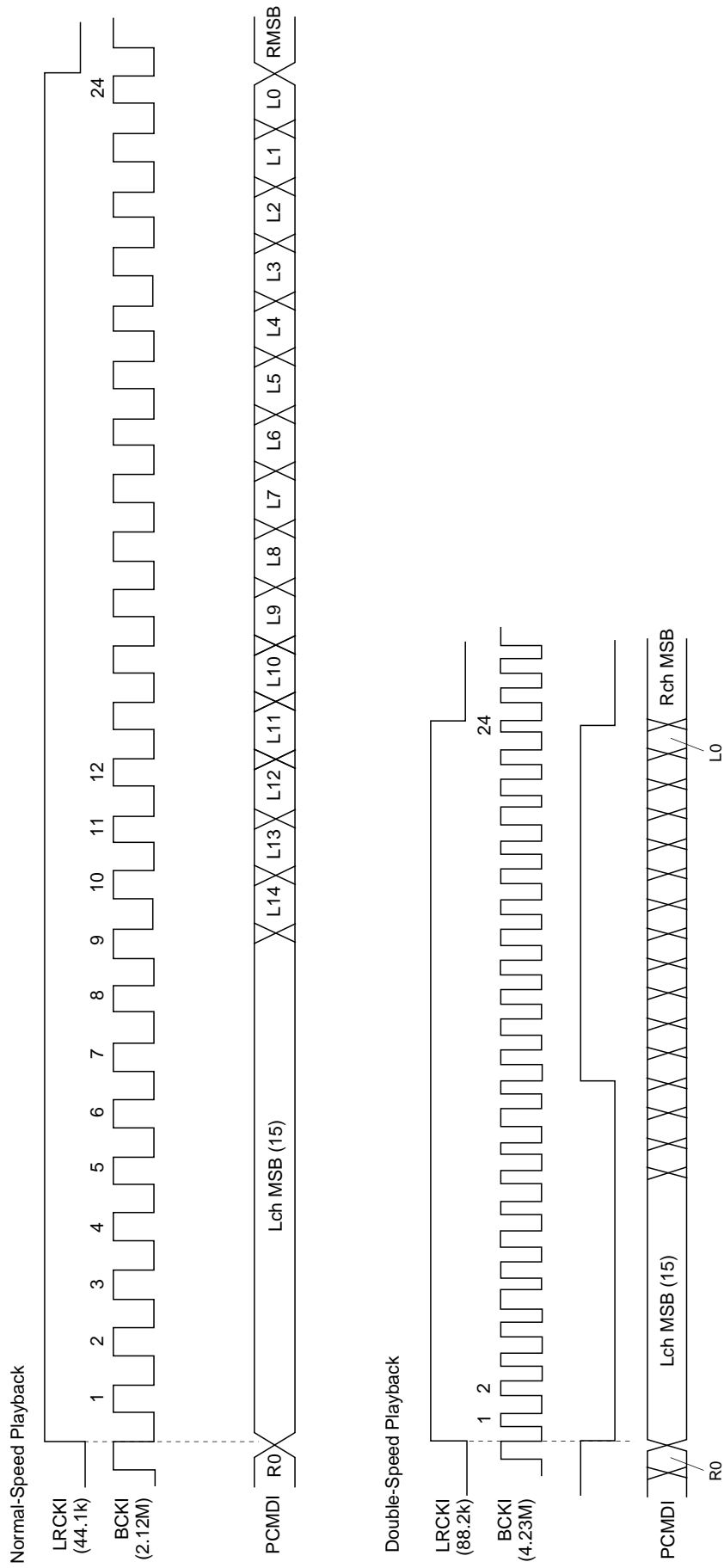

DAC Block Input Timing

### 3-11. LPF Block

The CXD2548R contains an initial-stage secondary active LPF with numerous resistors and capacitors and an operational amplifier with reference voltage.

The resistors and capacitors are attached externally, allowing the cut-off frequency  $f_c$  to be determined flexibly. The reference voltage ( $V_c$ ) is  $(AV_{DD} - AV_{SS})/2$ .

The LPF block application circuit is shown below.

In this circuit, the cut-off frequency is  $f_c \approx 40\text{kHz}$ .

The capacitance of the external capacitors when  $f_c = 30\text{kHz}$  and  $50\text{kHz}$  are noted below as a reference.

- When  $f_c \approx 30\text{kHz}$ :  
 $C1 = 200\text{pF}$ ,  $C2 = 910\text{pF}$
- When  $f_c \approx 50\text{kHz}$ :  
 $C1 = 120\text{pF}$ ,  $C2 = 560\text{pF}$

#### LPF Block Application Circuit

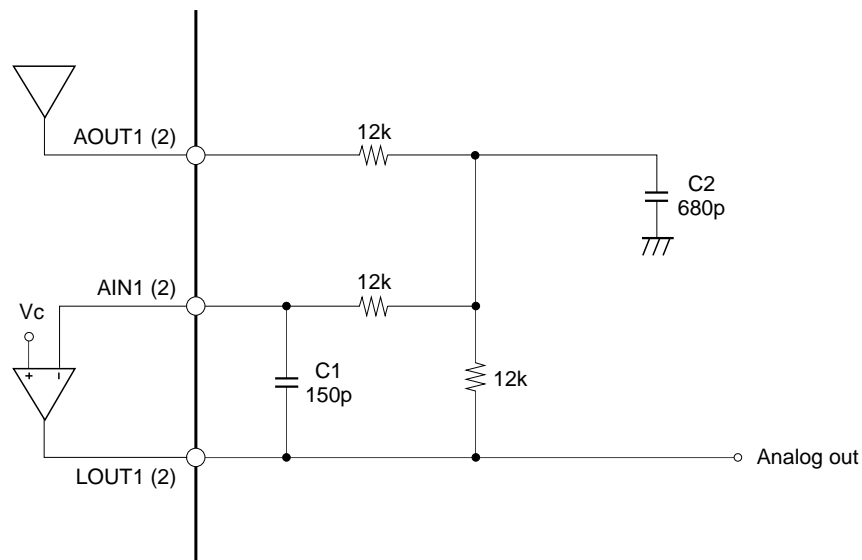

Fig. 3-12. LPF External Circuit

### 3-12. Setting the Playback Speed for the CD-DSP and 1-bit DAC Blocks (in CLV-N mode)

#### (a) CD-DSP block

In the CXD2548R, the following playback modes can be selected through different combinations of the crystal, XTSL pin and the DSPB command of \$9X.

**CD-DSP block playback speed**

X'tal	XTSL	DSPB	CD-DSP block playback speed
768Fs	1	0	1 ×
768Fs	1	1	2 ×
384Fs	0	0	1 ×
384Fs	0	1	2 ×
384Fs	1	1	1 × <sup>*1</sup>

Fs = 44.1kHz.

<sup>\*1</sup> Low power consumption mode. The CD-DSP processing speed is halved, allowing power consumption to be reduced.

#### (b) 1-bit DAC block

The operation speed for the DAC block is determined by the crystal and the MCSL command of \$9X regardless of the CD-DSP operating conditions noted above. This allows the playback modes for the DAC and CD-DSP blocks to be set independently.

**1-bit DAC block playback speed**

X'tal	MCSL	DAC block playback speed
768Fs	1	1 ×
768Fs	0	2 ×
384Fs	0	1 ×

Fs = 44.1kHz.

## [4] Description of Servo Signal Processing System Functions and Commands

### §4-1. General Description of the Servo Signal Processing System

(Voltages are the values for a 5V power supply.)

#### Focus servo

Sampling rate:	88.2kHz
Input range:	2.5V center $\pm 1.0V$
Output format:	7-bit PWM
Others:	Offset cancel Focus bias adjustment Focus search Gain-down function Defect countermeasure Auto gain control

#### Tracking servo

Sampling rate:	88.2kHz
Input range:	2.5V center $\pm 1.0V$
Output format:	7-bit PWM
Others:	Offset cancel E:F balance adjustment Track jump Gain-up function Defect countermeasure Drive cancel Auto gain control Vibration countermeasure

#### Sled servo

Sampling rate:	345Hz
Input range:	2.5V center $\pm 1.0V$
Output format:	7-bit PWM
Others:	Sled move

#### FOK, MIRR, DFCT signals generation

RF signal sampling rate:	1.4MHz
Input range:	2.15V to 5.0V
Others:	RF zero level automatic measurement The signal input from the RFDC pin is multiplied by a factor of 0.7 and loaded into the A/D converter.

**§4-2. Digital Servo Block Master Clock (MCK)**

The FSTI pin is the reference clock input pin. The internal master clock (MCK) is generated by dividing the frequency of the signal input to FSTI. The frequency division ratio is 1/2 or 1/4.

Table 4-1 below shows the hypothetical case where the crystal clock generated from the digital signal processor block is 2/3 frequency-divided and input to the FSTI pin by externally connecting the FSTI pin and the FSTO pin.

The XT4D and XT2D command settings can be made with D13 and D12 of \$3F. (Default = 0)

The digital servo block is designed with an MCK frequency of 5.6448MHz.

Mode	X'tal	FSTO	FSTI	XTSL	XT4D	XT2D	Frequency division ratio	MCK frequency
1	384Fs	256Fs	256Fs	*	0	1	1/2	128Fs
2	384Fs	256Fs	256Fs	0	0	0	1/2	128Fs
3	768Fs	512Fs	512Fs	*	1	0	1/4	128Fs
4	768Fs	512Fs	512Fs	1	0	0	1/4	128Fs

Fs = 44.1kHz, \*: Don't care

**Table 4-1.**

**§4-3. AVRG (Average) Measurement and Compensation**

The CXD2548R has a circuit that measures AVRG of RFDC, VC, FE, and TE and a circuit that compensates them to control servo effectively.

AVRG measurement and compensation is necessary to initialize the CXD2548R, and is able to cancel the offset by performing each AVRG measurement before playback operation and using these results for compensation.

The level applied to the VC, FE, RFDC and TE pins can be measured by setting D15 (VLCM), D13 (FLM), D11 (RFLM) and D4 (TCLM) of \$38 respectively to 1.

AVRG measurement consists of digitally measuring the level applied to each analog input pin by taking the average of 256 samples, and then loading these values into the AVRG register.

AVRG measurement requires approximately 2.9ms to 5.8ms after the command is received.

During AVRG measurement, if the upper 8 bits of the serial data are 38 (Hex), the completion of AVRG measurement operation can be confirmed through the SENS pin. (See Timing Chart 4-1.)

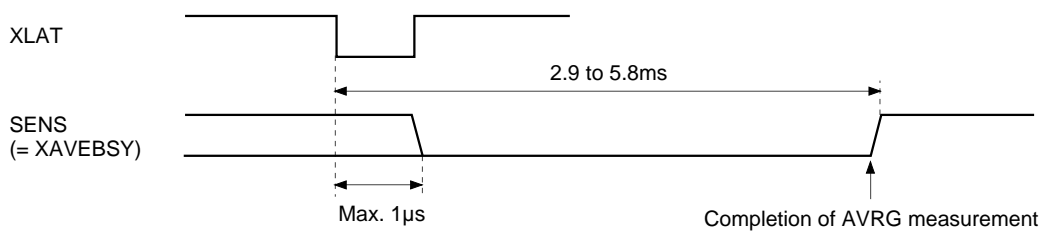

**Timing Chart 4-1.**

**<Measurement>**

## • VC AVRG

The offset can be canceled by measuring the VC level which is the center voltage for the system and using that value to apply compensation to each input error signal.

## • FE AVRG

The FE signal DC level is measured. In addition, compensation is applied to the FZC comparator level output from the SENS pin during FCS SEARCH (focus search) using these measurement results.

## • TE AVRG

The TE signal DC level is measured.

## • RE AVRG

The MIRR, DFCT and FOK signals are generated from the RF signal. However, the FOK signal is generated by comparing the RF signal at a certain level, so that it is necessary to establish a zero level which becomes the comparator level reference. Therefore, the RF signal is measured before playback operation, and compensation is applied to bring this level to the zero level.

An example of sending AVRG measurement and compensation commands is shown below.

**(Example)** \$380800 (RF Avg. measurement on)  
 \$382000 (FE Avg. measurement on)  
 \$380010 (TE Avg. measurement on)  
 \$388000 (VC Avg. measurement on)  
 (Complete each AVRG measurement before starting the next.)  
 \$38140A (RFLC, FLC0, FLC1 and TLC1 commands on)  
 (The required compensation should be turn on together; see Fig. 4-2.)

An interval of 5.8ms or more must be maintained between each command, or the SENS pin must be monitored to confirm that the previous command has been completed before the next AVRG command is sent.

**<Compensation>**

See Fig. 4-2 for the contents of each compensation below.

## • RFLC

The difference by which the RF signal exceeds the RF AVRG value is input to the RF In register.

## • TCL0

The value obtained by subtracting the VC AVRG value from the TE signal is input to the TRK In register.

## • TCL1

The value obtained by subtracting the TE AVRG value from the TE signal is input to the TRK In register.

## • VCLC

The value obtained by subtracting the VC AVRG value from the FE signal is input to the FCS In register.

## • FLC1

The value obtained by subtracting the FE AVRG value from the FE signal is input to the FCS In register.

## • FLC0

The value obtained by subtracting the FE AVRG value from the FE signal is input to the FZC register.

**§4-4. E:F Balance Adjustment Function**

When the disc is rotated with the laser on, and with the FCS (focus) servo on via FCS Search (focus search), the traverse waveform appears in the TE signal due to disc eccentricity.

In this condition, the low-frequency component can be extracted from the TE signal using the built-in TRK hold filter by setting D5 (TBLM) of \$38 to 1.

The extracted low-frequency component is loaded into the TRVSC register as a digital value, and the TRVSC register value is established when TBLM returns to 0.

Next, setting D2 (TLC2) of \$38 to 1 applies only the amount of compensation (subtraction) equal to the TRVSC register value to the values obtained from the TE and SE input pins, enabling the E:F balance offset to be adjusted. (See Fig. 4-2.)

**§4-5. FCS Bias (Focus Bias) Adjustment Function**

The FBIAS register value can be added to the FCS servo filter input by setting D14 (FBON) of \$3A to 1. (See Fig. 4-2.)

When the FBIAS register value is set to D11 = 0 and D10 = 1 by \$34F, data can be written using the 9-bit value of D9 to D1 (D9: MSB).

In addition, the RF jitter can be monitored by setting the SOCT and SLO commands of \$B to 1. (See "DSP Block Timing Chart".)

The FBIAS register can be used as a counter by setting D13 (FBSS) of \$3A to 1. It operates as an up/down counter. The FBIAS register functions as an up counter when D12 (FBUP) of \$3A = 1, and as a down counter when D12 (FBUP) of \$3A = 0.

The number of up and down steps can be changed by setting D11 and D10 (FBV1 and FBV0) of \$3A.

When using the FBIAS register as a counter, the counter stops when the value set beforehand in FBL9 to 1 of \$34 matches the FCSBIAS value. Also, if the upper 8 bits of the command register are \$3A at this time, the counter stop can be monitored through SENS.

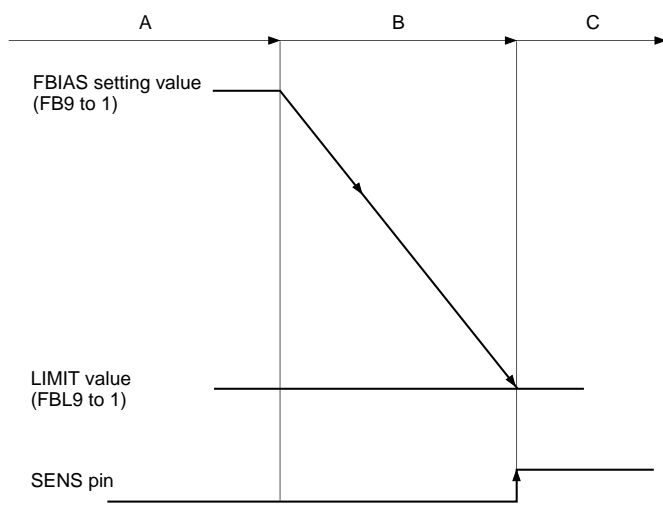

Here, the FBIAS setting values FB9 to 1 and the FBIAS LIMIT values FBL9 to 1 are assumed to be set in status A. For example, if command registers FBUP = 0, FBV1 = 0, FBV0 = 0 and FBSS = 1 are set from this status, down count starts from status A and approaches the set LIMIT value. When the LIMIT value is reached and the FBIAS value matches FBL9 to 1, the counter stops and the SENS pin goes to high. Note that the up/down counter changes with each sampling cycle of the focus servo filter. The number of steps by which the count value changes can be selected from 1, 2, 4 or 8 steps by FBV1 and FBV0. When converted to FE input, 1 step corresponds to approximately 3.9 [mV].

A: Register mode  
 B: Counter mode  
 C: Counter mode (when stopped)

**Fig. 4-1.**

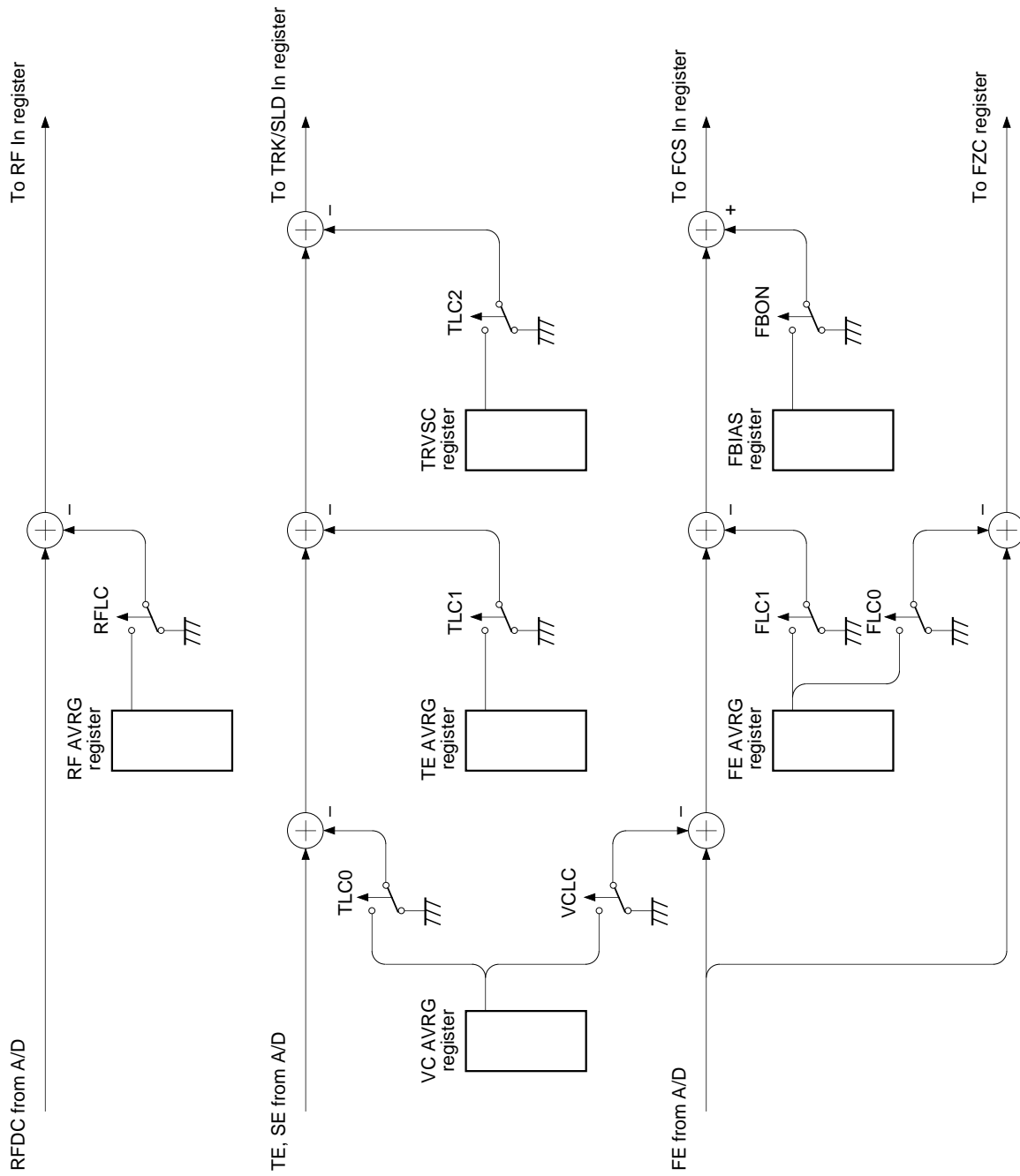

Fig. 4-2.

#### §4-6. AGCNTL (Auto Gain Control) Function

The AGCNTL function automatically adjusts the filter internal gain in order to obtain the appropriate gain with the servo loop. AGCNTL not only copes with the sensitivity variation of the actuator and photo diode, etc., but also obtains the optimal gain for each disc.

The AGCNTL command is sent when each servo is turned on. During AGCNTL operation, if the upper 8 bits of the serial data are 38 (Hex), the completion of AGCNTL operation can be confirmed through the SENS pin. (See Timing Chart 4-2 and "Description of SENS Signals".)

Setting D9 and D8 of \$38 to 1 set FCS (focus) and TRK (tracking) respectively to AGCNTL operation.

**Note)** During AGCNTL operation, each servo filter gain must be normal, and the anti-shock circuit (described hereafter) must be disabled.

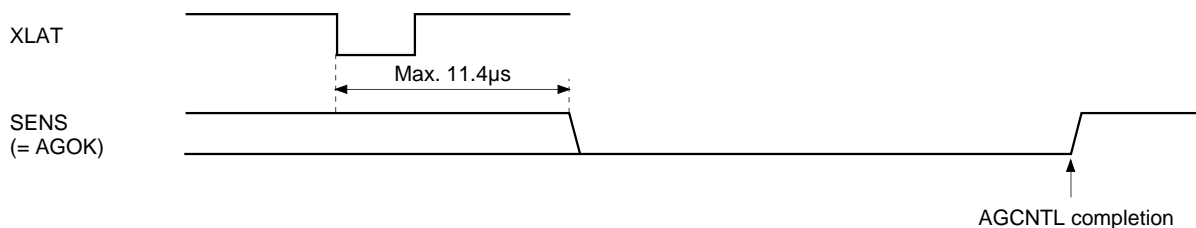

**Timing Chart 4-2.**

Coefficient K13 changes for AGF (focus AGCNTL) and coefficients K23 and K07 change for AGT (tracking AGCNTL) due to AGCNTL.

These coefficients change from 01 to 7F (Hex), and they must also be set within this range when written externally.

After AGCNTL operation has completed, these coefficient values can be confirmed by reading them out from the SENS pin with the serial readout function (described hereafter).

#### AGCNTL related setting

The following settings can be changed with \$35, \$36 and \$37.

FG6 to FG0; AGF convergence gain setting, effective setting range: 00 to 57 (Hex)

TG6 to TG0; AGT convergence gain setting, effective setting range: 00 to 57 (Hex)

AGS; Self-stop on/off

AGJ; Convergence completion judgment time

AGGF; Internally generated sine wave amplitude (AGF)

AGGT; Internally generated sine wave amplitude (AGT)

AGV1; AGCNTL sensitivity 1 (during high sensitivity adjustment)

AGV2; AGCNTL sensitivity 2 (during low sensitivity adjustment)

AGHS; High sensitivity adjustment on/off

AGHT; High sensitivity adjustment time

**Note)** Converging servo loop gain values can be changed with the FG6 to 0 and TG6 to 0 setting values. In addition, these setting values must be within the effective setting range. The default settings aim for 0 dB at 1kHz. However, since convergence values vary according to the characteristics of each constituent element of the servo loop, FG and TG values should be set as necessary.

AGCNTL and default operation have two stages.

In the first stage, high sensitivity adjustment is performed for a certain period of time (select 256/128ms with AGHT), and the AGCNTL coefficient approaches the appropriate value roughly. The sensitivity at this time can be selected from two types with AGV1.

In the second stage, the AGCNTL coefficient approaches the appropriate value finely with relatively low sensitivity. The sensitivity for the second stage can be selected from two types with AGV2. In the second stage of default operation, when the AGCNTL coefficient reaches the appropriate value and stops changing, the CXD2548R confirms that the AGCNTL coefficient has not changed for a certain period of time (select 63/31ms with AGHJ), and then completes AGCNTL operation. (Self-stop mode)

This self-stop mode can be canceled by setting AGS to 0.

In addition, the first stage is omitted for AGCNTL operation when AGHS is set to 0.

An example of AGCNTL coefficient transitions during AGCNTL operation and the relationship between the various settings are shown in Fig. 4-3.

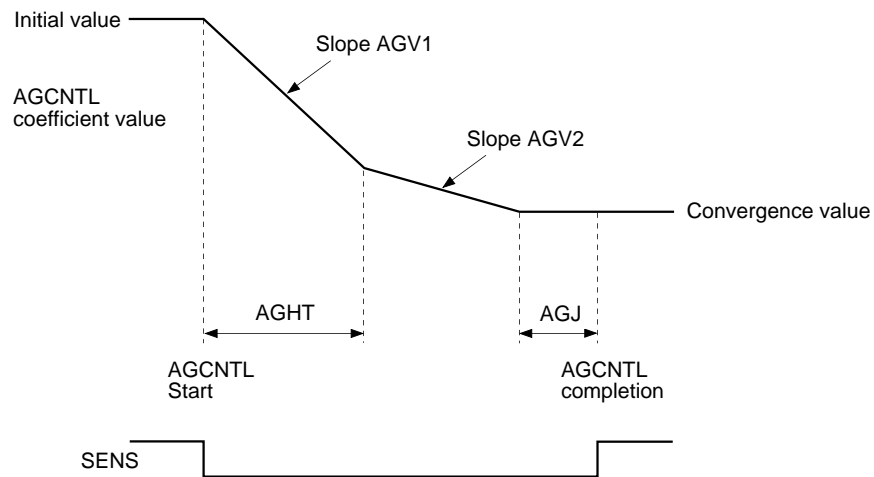

Fig. 4-3.

**§4-7. FCS Servo and FCS Search (Focus Search)**

The FCS servo is controlled by the 8-bit serial command \$0X. (See Table 4-2.)

Register name	Command	D23 to D20	D19 to D16	
0	FOCUS CONTROL	0 0 0 0	1 0 * *	FOCUS SERVO ON (FOCUS GAIN NORMAL)
			1 1 * *	FOCUS SERVO ON (FOCUS GAIN DOWN)
			0 * 0 *	FOCUS SERVO OFF, 0V OUT
			0 * 1 *	FOCUS SERVO OFF, FOCUS SEARCH VOLTAGE OUT
			0 * 1 0	FOCUS SEARCH VOLTAGE DOWN
			0 * 1 1	FOCUS SEARCH VOLTAGE UP

\*: Don't care

**Table 4-2.**

**FCS Search**

FCS search is required in the course of turning on the FCS servo.

Fig. 4-4 shows the signals for sending commands \$00 → \$02 → \$03 and performing only FCS search.

Fig. 4-5 shows the signals for sending \$08 (FCS on) after that.

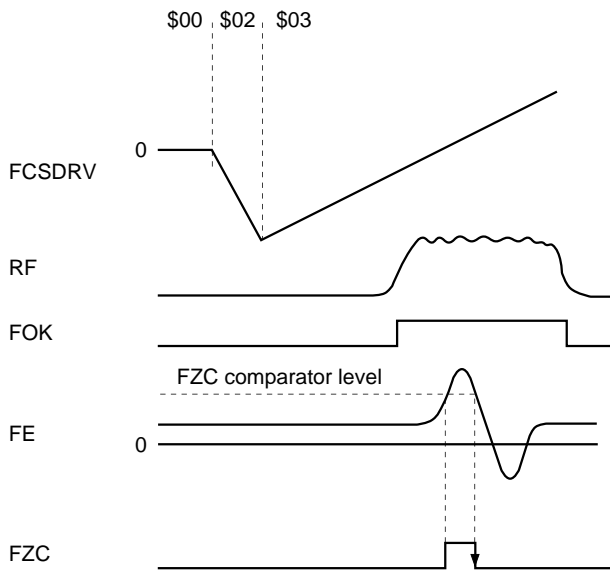

**Fig. 4-4.**

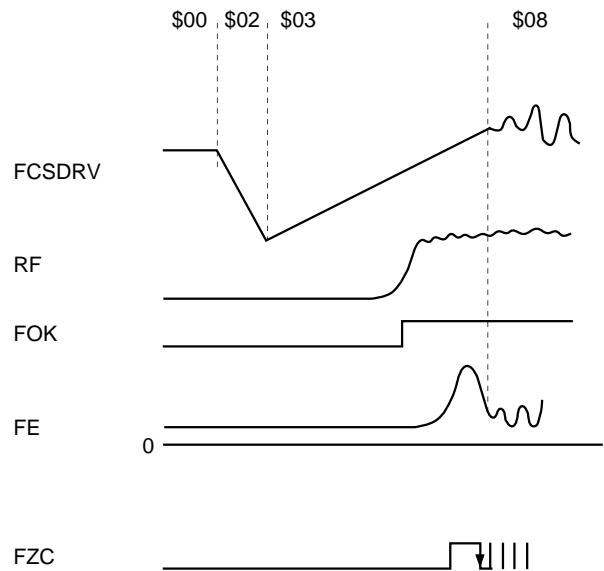

**Fig. 4-5.**

#### §4-8. TRK (Tracking) and SLD (Sled) Servo Control

TRK and SLD servo is controlled by the 8-bit command \$2X. (See Table 4-3.)

When the upper 4 bits of the serial data are 2 (Hex), TZG is output from the SENS pin.

Register name	Command	D23 to D20	D19 to D16	
2	TRACKING MODE	0 0 1 0	0 0 * *	TRACKING SERVO OFF
			0 1 * *	TRACKING SERVO ON
			1 0 * *	FORWARD TRACK JUMP
			1 1 * *	REVERSE TRACK JUMP
			* * 0 0	SLED SERVO OFF
			* * 0 1	SLED SERVO ON
			* * 1 0	FORWARD SLED MOVE
			* * 1 1	REVERSE SLED MOVE

\*: Don't care

Table 4-3.

#### TRK Servo

The TRK JUMP (track jump) height can be set with 6 bits (D13 to D8) of \$36.

In addition, when the TRK servo is on and D17 of \$1 is set to 1, the TRK servo filter assumes gain-up status. The filter also assumes gain-up status when vibration detection is performed with the LOCK signal low and the anti-shock circuit (described hereafter) enabled.

The gain-up filter used when TRK has assumed gain-up status has two types of structures which can be selected by setting D16 of \$1. (See Table 4-5.)

#### SLD Servo

The SLD MOV (sled move) output, composed of a basic value from 6 bits (D13 to D8) of \$37, is determined by multiplying this value by 1 ×, 2 ×, 3 ×, or 4 × magnification set using D17 and D16 when D19 = D18 = 0 is set with \$3. (See Table 4-4.)

SLD MOV must be performed continuously for 50μs or more. In addition, if the LOCK input signal goes low when the SLD servo is on, the SLD servo turns off.

**Note)** When the LOCK signal is low, the TRK servo is set to gain-up status and the SLD servo is turned off by the default. These operations are disabled by setting D6 (LKSW) of \$38 to 1.

Register name	Command	D23 to D20	D19 to D16	
3	SELECT	0 0 1 1	0 0 0 0	SLED KICK LEVEL (basic value × ±1)
			0 0 0 1	SLED KICK LEVEL (basic value × ±2)
			0 0 1 0	SLED KICK LEVEL (basic value × ±3)
			0 0 1 1	SLED KICK LEVEL (basic value × ±4)

Table 4-4.

**§4-9. MIRR and DFCT Signal Generation**

The RF signal obtained from the RFDC pin is sampled at approximately 1.4MHz and loaded. The MIRR and DFCT signals are generated from this RF signal.

**MIRR Signal Generation**

The loaded RF signal is applied to peak hold and bottom hold circuits.

An envelope is generated from the waveforms generated in these circuits, and the MIRR comparator level is generated from the average of these envelope waveforms.

The MIRR signal is generated by comparing this MIRR comparator level with the waveform generated by subtracting the bottom hold value from the peak hold value. (See Fig. 4-6.)

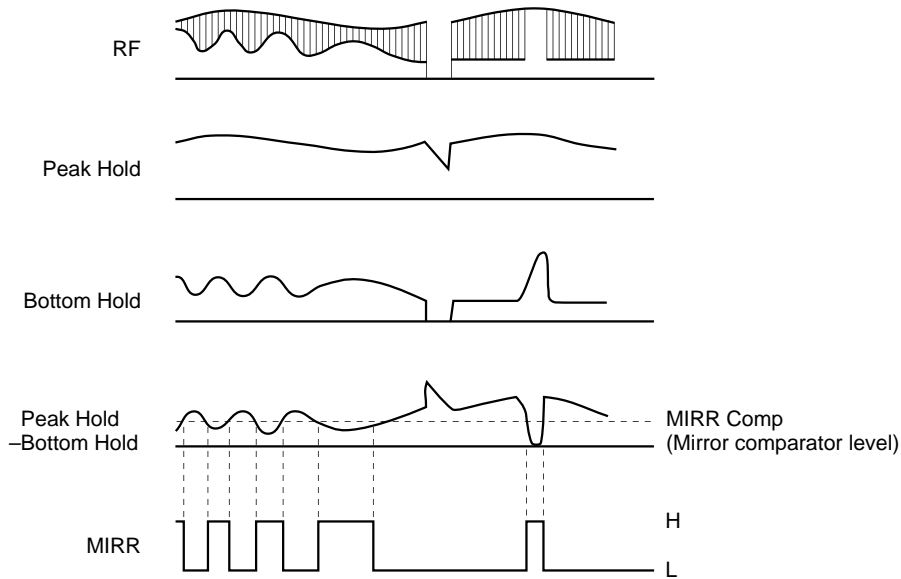

Fig. 4-6.

**DFCT Signal Generation**

The loaded RF signal is input to two peak hold circuits with different time constants, and the DFCT signal is generated by comparing the difference between these two peak hold waveforms with the DFCT comparator level. (See Fig. 4-7.)

The DFCT comparator level can be selected from four values using D13 and D12 of §3B.

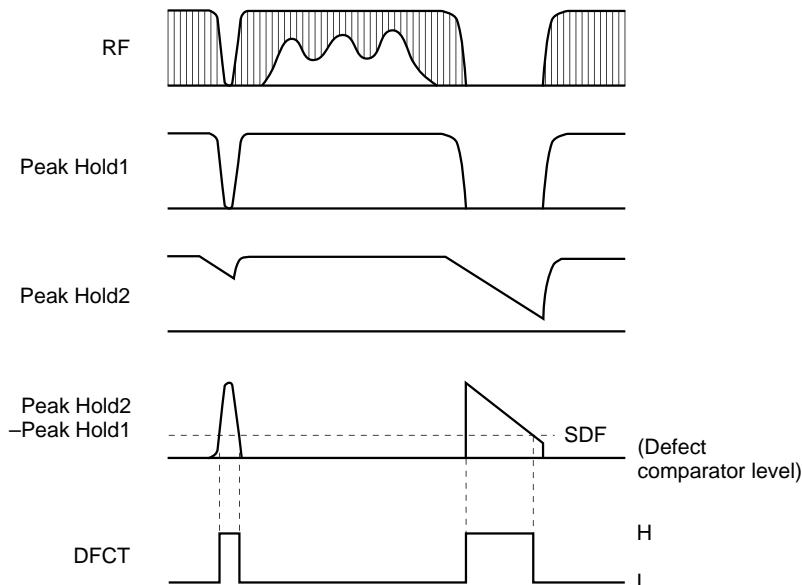

Fig. 4-7.

**§4-10. DFCT Countermeasure Circuit**

The DFCT countermeasure circuit performs operations to maintain the directionality of the servo so that the servo does not become easily dislocated due to scratches or defects on discs.

Specifically, these operations are achieved by performing scratch and defect detection with the DFCT signal generation circuit, and when DFCT goes high, applying the low frequency component of the error signal before DFCT went high to the FCS and TRK servo filter inputs. (See Fig. 4-8.)

In addition, these operations are activated by the default. They can be disabled by setting D7 (DFSW) of \$38 to 1.

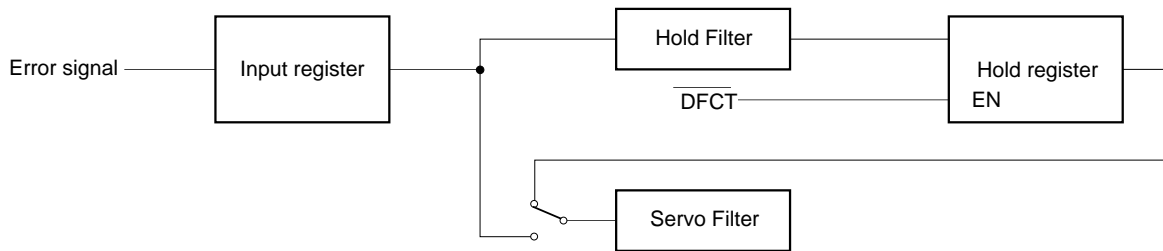

**Fig. 4-8.**

**§4-11. Anti-Shock Circuit**

When vibrations are produced in the CD player, this circuit forces the TRK filter to assume gain-up status so that the servo does not become easily dislocated. This circuit is for systems which require vibration countermeasures.

Concretely, vibrations are detected using an internal anti-shock filter and comparator circuit, and the gain is increased. (See Fig. 4-9.)

The comparator level is fixed to 1/16 of the maximum comparator input amplitude. However, the comparator level is practically variable by adjusting the anti-shock filter output coefficient K35.

This function can be turned on and off by D19 of \$1 when the brake circuit (described hereafter) is off. (See Table 4-5.)

This circuit can also support an external vibration detection circuit, and can set the TRK servo filter to gain-up status by inputting high level to the ATSK pin.

When the serial data is \$1, vibration detection can be monitored from the SENS pin.

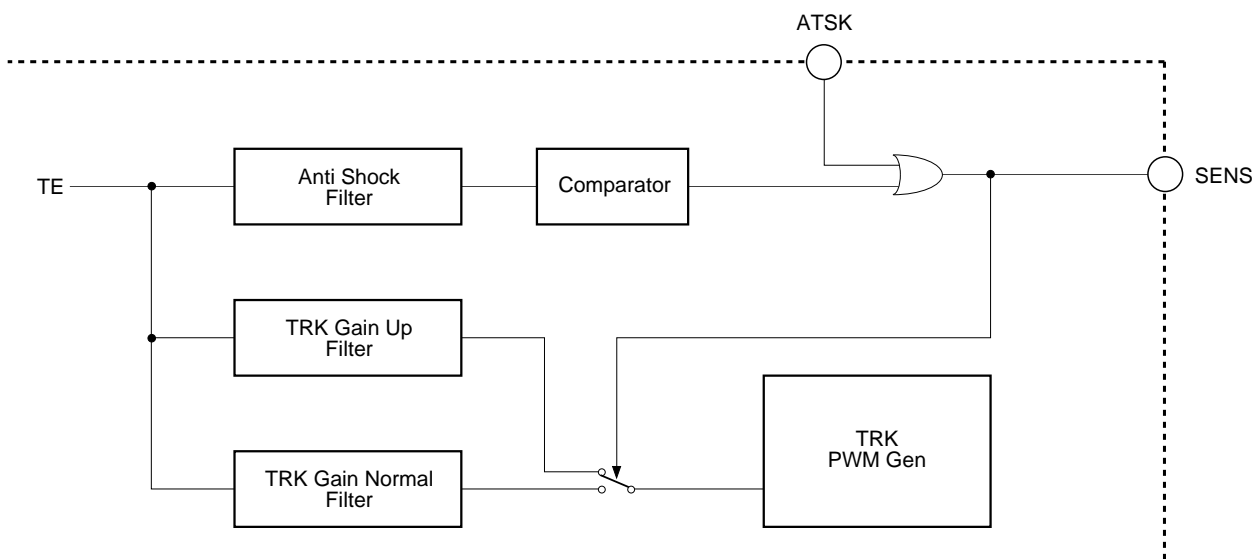

**Fig. 4-9.**

**§4-12. Brake Circuit**

Immediately after a long distance track jump it tends to be hard for the actuator to settle and for the servo to turn on.

The brake circuit prevents these phenomenon.

In principle, this circuit cuts unnecessary portions of the tracking drive and applies the brake by utilizing the 180° offset in the RF envelope and tracking error phase relationship which occurs when the actuator traverses the track in the radial direction from the inner track to the outer track and vice versa. (See Figs. 4-10 and 4-11.) Concretely, this operation is achieved by masking the tracking drive using the TRKCNCL signal generated by loading the MIRR signal at the edge of the TZC (Tracking Zero Cross) signal.

The brake circuit can be turned on and off by D18 of \$1. (See Fig. 4-5.)

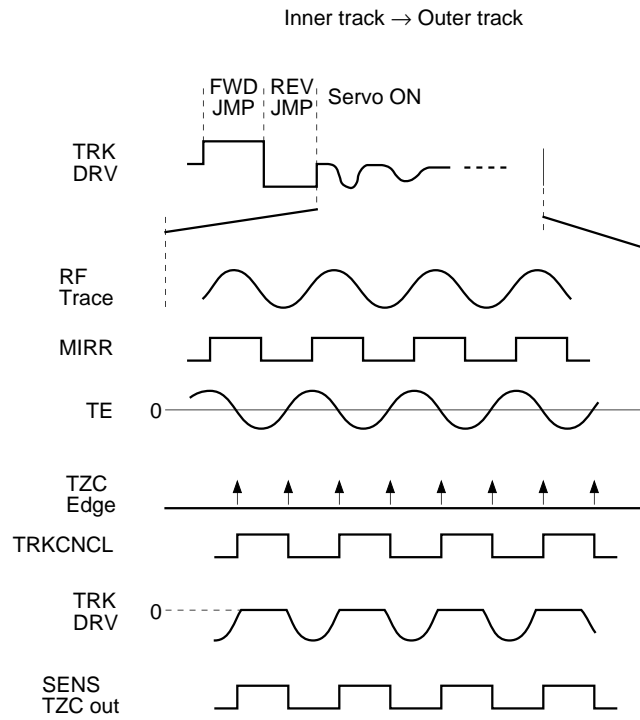

**Fig. 4-10.**

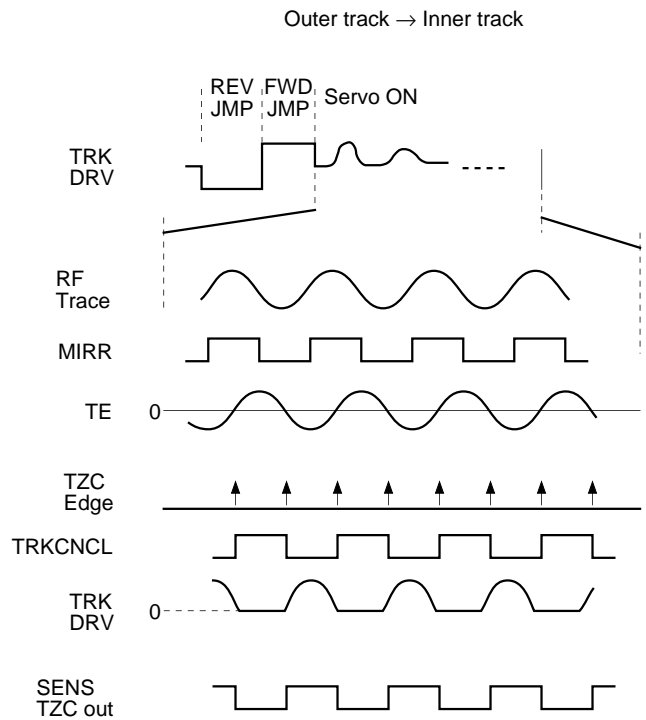

**Fig. 4-11.**

Register name	Command	D23 to D20	D19 to D16	
1	TRACKING CONTROL	0 0 0 1	1 0 * *	ANTI SHOCK ON
			0 * * *	ANTI SHOCK OFF
			* 1 * *	BRAKE ON
			* 0 * *	BRAKE OFF
			* * 0 *	TRACKING GAIN NORMAL
			* * 1 *	TRACKING GAIN UP
			* * * 1	TRACKING GAIN UP FILTER SELECT 1
			* * * 0	TRACKING GAIN UP FILTER SELECT 2

\*: Don't care

**Fig. 4-5.**

**§4-13. COUT Signal**

The COUT signal is output to count the number of tracks during traverse, etc. It is basically generated by loading the MIRR signal at both edges of the TZC signal. However, the used TZC signal can be selected and there are two types of output methods according to the COUT signal application.

For 1-track jumps, etc.

Fast phase COUT signal generation with a fast phase TZC signal.

For High-speed traverse

Reliable COUT signal generation with a delayed phase TZC signal.

This is because some time is required to generate the MIRR signal, and it is necessary to delay the TZC signal in accordance with the MIRR signal delay during high-speed traverse.

The COUT signal output method is switched with D16 when D19 = D18 = 1 and D17 = 0 are set with \$3. (When D16 = 1, for delayed phase and high-speed traverse.) In addition, the TZC signal delay can be selected from two values with D14 of \$36.

**§4-14. Serial Readout Circuit**

The following measurement and adjustment results can be read out from the SENS pin by inputting the readout clock to the SCLK pin by \$39. (See Fig. 4-12, Table 4-6 and "Description of SENS Signals".)

Specified commands

- \$390C VC AVRG measurement result
- \$3908 FE AVRG measurement result
- \$3904 TE AVRG measurement result
- \$391F RF AVRG measurement result
- \$3953 FCS AGCNTL coefficient result
- \$3963 TRK AGCNTL coefficient result
- \$391C TRVSC adjustment result
- \$391D FBIAS register value

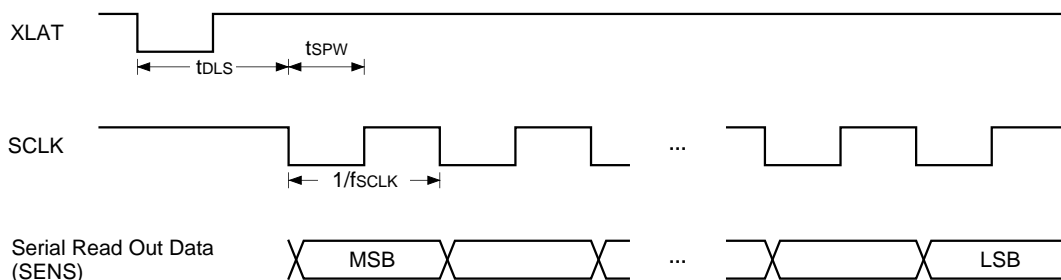

**Fig. 4-12.**

Item	Symbol	Min.	Typ.	Max.	Unit
SCLK frequency	f <sub>SCLK</sub>			1	MHz
SCLK pulse width	t <sub>SPW</sub>	500			ns
Delay time	t <sub>DLS</sub>	15			μs

**Table 4-6.**

During readout, the upper 8 bits of the serial data must be 39 (Hex).

**§4-15. Writing the Coefficient RAM**

The coefficient RAM can be rewritten by \$34. All coefficients have default values in the built-in ROM, and transfer from the ROM to the RAM is completed approximately 40µs after the XRST pin rises. (The coefficient RAM cannot be rewritten during this period.)

After that, the characteristics of each built-in filter can be finely adjusted by rewriting the data for each address of the coefficient RAM.

The coefficient rewrite command is comprised of 24 bits, with D14 to D8 of \$34 as the address (D15 = 0) and D7 to D0 as data.

**§4-16. PWM Output**

FCS, TRK and SLD outputs are output as PWM waveforms.

In particular, FCS and TRK permit accurate drive by using a double oversampling noise shaper.

Timing Chart 4-3 and Fig. 4-13 show examples of output waveforms and drive circuits.

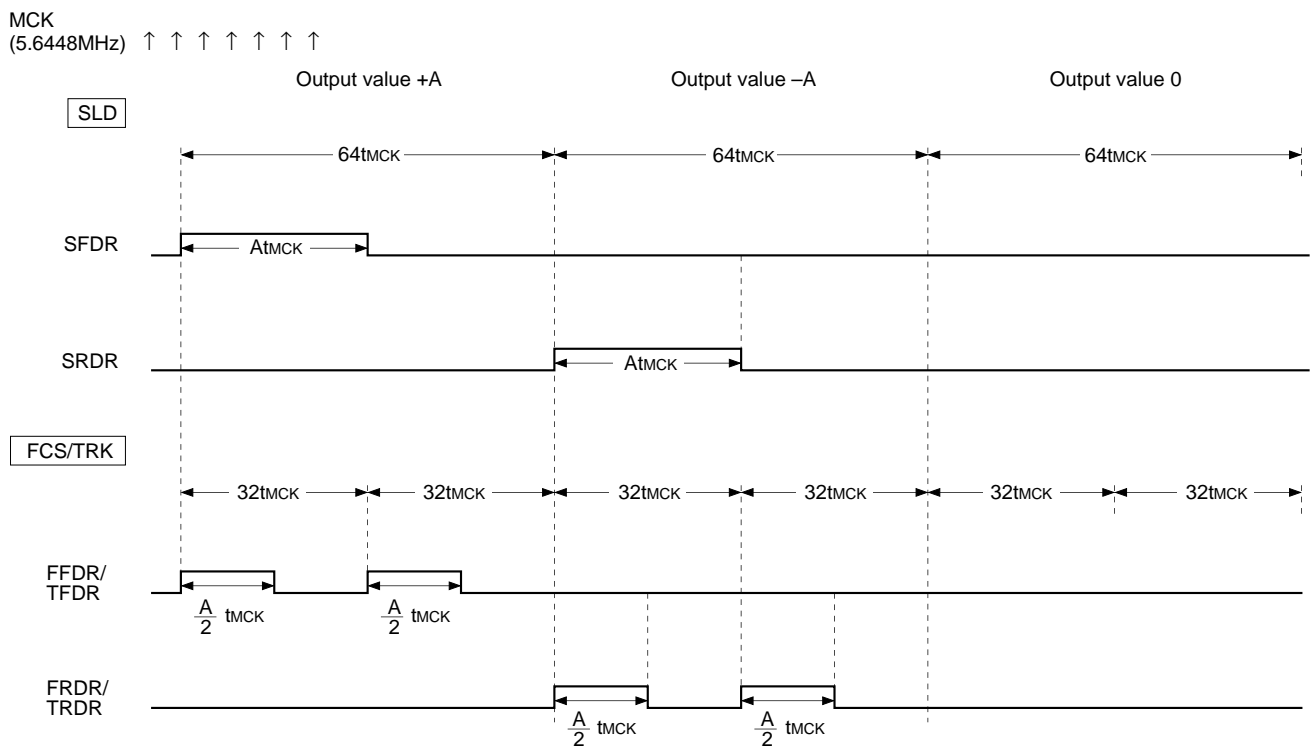

$$t_{MCK} = \frac{1}{5.6448\text{MHz}} \approx 180\text{ns}$$

**Timing Chart 4-3.**

Example of Drive Circuit

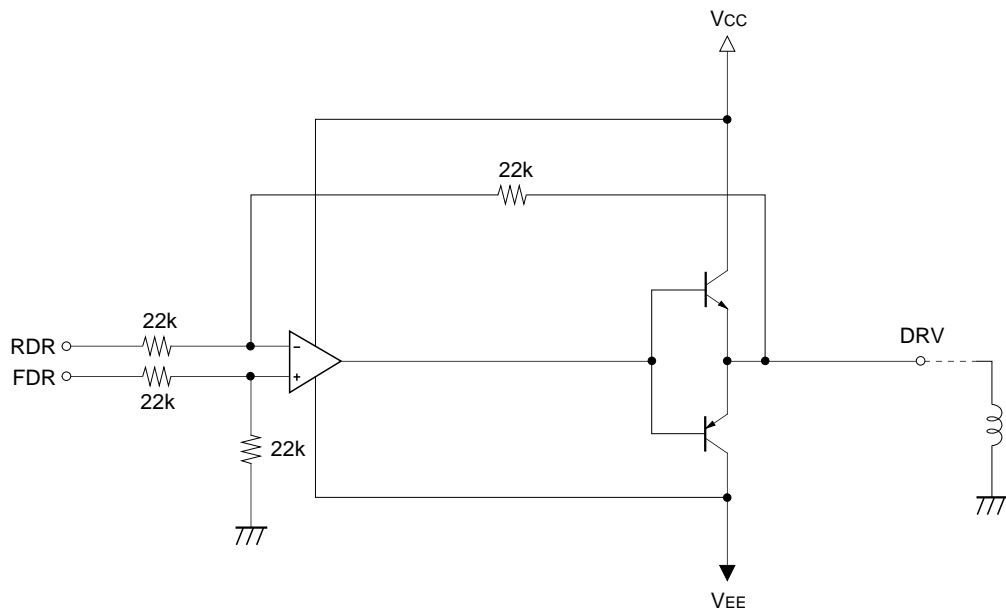

Fig. 4-13. Operational Amplifier Drive Circuit

**§4-17. Servo Status Changes Produced by the LOCK Signal**

When the LOCK signal becomes low, the TRK servo assumes the gain-up status and the SLD servo turns off in order to prevent SLD free-running.

Setting D6 (LKS) of \$38 to 1 deactivates this function.

In other words, neither the TRK servo nor the SLD servo change even when the LOCK signal becomes low.

This enables microcomputer control.

**§4-18. Description of Commands and Data Sets**

The following description contains portions which convert internal voltages into the values when they are output externally and describe them as input conversion or output conversion.

Input conversion converts these voltages into the voltages entering input pins before A/D conversion.

Output conversion converts PWM output values into analog voltage values.

Both types of conversion are calculated at  $V_{DD} = 5.0V$ . If this voltage changes, the conversion values also change proportionally. (Voltage conversion =  $V_{DD}/5$ ;  $V_{DD}$ : used supply voltage)

**\$34**

D15	D14	D13	D12	D11	D10	D9	D8	D7	D6	D5	D4	D3	D2	D1	D0
0	KA6	KA5	KA4	KA3	KA2	KA1	KA0	KD7	KD6	KD5	KD4	KD3	KD2	KD1	KD0

When D15 = 0

KA6 to KA0: Coefficient address

KD7 to KD0: Coefficient data

D15	D14	D13	D12	D11	D10	D9	D8	D7	D6	D5	D4	D3	D2	D1	D0
1	1	1	1	1	0	FBL9	FBL8	FBL7	FBL6	FBL5	FBL4	FBL3	FBL2	FBL1	—

When D15 = D14 = D13 = D12 = D11 = 1 (\$34F)

D10 = 0

FBIAS LIMIT register write

FBL9 to FBL1: Data; data compared with FB9 to 1, FBL9 = MSB.

When using the FBIAS register in counter mode, counter operation stops when the value of FB9 to 1 matches with FBL9 to 1.

D15	D14	D13	D12	D11	D10	D9	D8	D7	D6	D5	D4	D3	D2	D1	D0
1	1	1	1	0	1	FB9	FB8	FB7	FB6	FB5	FB4	FB3	FB2	FB1	—

When D15 = D14 = D13 = D12 = 1. (\$34F)

D11 = 0, D10 = 1

FBIAS register write

FB9 to FB1: Data; FB9 is MSB two's complement data.

For FE input conversion, FB9 to FB1 = 01111111 corresponds to approximately +1V and FB9 to FB1 = 10000000 to -1V respectively. (when the supply voltage = 5V)

D15	D14	D13	D12	D11	D10	D9	D8	D7	D6	D5	D4	D3	D2	D1	D0
1	1	1	1	0	0	TV9	TV8	TV7	TV6	TV5	TV4	TV3	TV2	TV1	TV0

When D15 = D14 = D13 = D12 = 1. (\$34F)

D11 = 0, D10 = 0

TRVSC register write

TV9 to TV0: Data; TV9 is MSB two's complement data.

For TE input conversion, TV9 to TV0 = 0011111111 corresponds to approximately +1V and TV9 to TV0 = 1100000000 to -1V respectively. (when the supply voltage = 5V)

- Note)**
- When the TRVSC register is read out, the data length is 9 bits. At this time, data corresponding to each bit of TV8 to TV0 during external write are read out.
  - When reading out internally measured values and then writing these values externally, set TV9 the same as TV8.

**\$35**

D15	D14	D13	D12	D11	D10	D9	D8	D7	D6	D5	D4	D3	D2	D1	D0
FT1	FT0	FS5	FS4	FS3	FS2	FS1	FS0	FTZ	FG6	FG5	FG4	FG3	FG2	FG1	FG0

FT1, FT0, FTZ: Focus search-up speed  
 Default value: 010 (3.36V/s)  
 Focus drive output conversion

FT1	FT0	FTZ	Focus search speed
0	0	0	6.73V/s
0	1	0	3.36
1	0	0	2.24
1	1	0	1.68
0	0	1	8.97
0	1	1	5.38
1	0	1	4.49
1	1	1	3.85

FS5 to FS0: Focus search limit voltage  
 Default value: 011000 ( $\pm 1.875V$ )  
 Focus drive output conversion  
 FG6 to FG0: AGF convergence gain setting value  
 Default value: 0101101

**\$36**

D15	D14	D13	D12	D11	D10	D9	D8	D7	D6	D5	D4	D3	D2	D1	D0
0	DTZC	TJ5	TJ4	TJ3	TJ2	TJ1	TJ0	SFJP	TG6	TG5	TG4	TG3	TG2	TG1	TG0

DTZC: DTZC delay (8.5/4.25 $\mu$ s)  
 Default value: 0 (4.25 $\mu$ s)  
 TJ5 to TJ0: Track jump voltage  
 Default value: 001110 ( $\approx \pm 1.09V$ )  
 Tracking drive output conversion  
 SFJP: Surf jump mode on/off  
 TRK PWM output is made by adding the tracking filter output and TJReg (TJ5 to 0), by setting D7 to 1 (on).  
 TG6 to TG0: AGT convergence gain setting value  
 Default value: 0101110

\$37

D15	D14	D13	D12	D11	D10	D9	D8	D7	D6	D5	D4	D3	D2	D1	D0
FZSH	FZSL	SM5	SM4	SM3	SM2	SM1	SM0	AGS	AGJ	AGGF	AGGT	AGV1	AGV2	AGHS	AGHT

FZSH, FZSL: FZC (Focus Zero Cross) slice level

Default value: 01 ( $\pm 250\text{mV}$ ); FE input conversion

FZSH	FZSL	Slice level
0	0	+500mV
0	1	+250
1	0	+125
1	1	+62.5

SM5 to SM0: Sled move voltage

Default value: 010000 ( $\approx \pm 1.25\text{V}$ )

Sled drive output conversion

AGS: AGCNTL self-stop on/off

Default value: 1 (on)

AGJ: AGCNTL convergence completion judgment time during low sensitivity adjustment (31/63ms)

Default value: 0 (63ms)

AGGF: Focus AGCNTL internally generated sine wave amplitude (small/large)

Default value: 1 (large)

AGGT: Tracking AGCNTL internally generated sine wave amplitude (small/large)

Default value: 1 (large)

	FE/TE input conversion
AGGF 0 (small)	63mV
1 (large)	125
AGGT 0 (small)	125mV
1 (large)	250

AGV1: AGCNTL convergence sensitivity during high sensitivity adjustment; high/low

Default value: 1 (high)

AGV2: AGCNTL convergence sensitivity during low sensitivity adjustment; high/low

Default value: 0 (low)

AGHS: AGCNTL high sensitivity adjustment on/off

Default value: 1 (on)

AGHT: AGCNTL high sensitivity adjustment time (128/256ms)

Default value: 0 (256ms)

**\$38**

D15	D14	D13	D12	D11	D10	D9	D8	D7	D6	D5	D4	D3	D2	D1	D0
VCLM	VCLC	FLM	FLC0	RFLM	RFLC	AGF	AGT	DFSW	LKSW	TBLM	TCLM	FLC1	TLC2	TLC1	TLC0

- \* VCLM: VC level measurement (on/off)
- VCLC: VC level compensation for FCS In register (on/off)
- \* FLM: Focus zero level measurement (on/off)
- FLC0: Focus zero level compensation for FZC register (on/off)
- \* RFLM: RF zero level measurement (on/off)
- RFLC: RF zero level compensation (on/off)
- AGF: Focus auto gain adjustment (on/off)
- AGT: Tracking auto gain adjustment (on/off)
- DFSW: Defect disable switch (on/off)  
Setting this switch to 1 (on) disables the defect countermeasure circuit.
- LKSW: Lock switch (on/off)  
Setting this switch to 1 disables the sled free-running prevention circuit.
- TBLM: Traverse center measurement (on/off)
- \* TCLM: Tracking zero level measurement (on/off)
- FLC1: Focus zero level compensation for FCS In register (on/off)
- TLC2: Traverse center compensation (on/off)
- TLC1: Tracking zero level compensation (on/off)
- TLC0: VC level compensation for TRK/SLD In register (on/off)

**Note)** Commands marked with \* are accepted every 2.9ms.  
All commands are on when set to 1.

**\$39**

D15	D14	D13	D12	D11	D10	D9	D8
DAC	SD6	SD5	SD4	SD3	SD2	SD1	SD0

DAC: Serial data readout DAC mode (on/off)

SD6 to SD0: Serial readout data select

SD6	SD5	Readout data		Readout data length		
1	Coefficient RAM data for address = SD5 to SD0			8 bit		
0	1	Data RAM data for address = SD4 to SD0		16 bit		
0	0	SD4	SD3 to SD0			
		1	1 1 1 1	RF AVR register	8 bit	
			1 1 1 0	RFDC input signal	8 bit	
			1 1 0 1	FBIAS register	9 bit	
			1 1 0 0	TRVSC register	9 bit	
			0 0 1 1	RFDC envelope (bottom)	8 bit	
			0 0 1 0	RFDC envelope (peak)	8 bit	
		0	0	1 1 * *	VC AVR register	9 bit
				1 0 * *	FE AVR register	9 bit
				0 1 * *	TE AVR register	9 bit
0 0 1 1	FE input signal			8 bit		
		0 0 1 0	TE input signal	8 bit		
		0 0 0 1	SE input signal	8 bit		
		0 0 0 0	VC input signal	8 bit		

**Note)** Coefficients K40 to K4F cannot be read out.

\*: Don't care

See the description for SRO1 of \$3F concerning readout methods for the above data.

**\$3A**

D15	D14	D13	D12	D11	D10	D9	D8	D7	D6	D5	D4	D3	D2	D1	D0
0	FBON	FBSS	FBUP	FBV1	FBV0	0	TJD0	FPS1	FPS0	TPS1	TPS0	CEIT	SJHD	INBK	MT10

**FBON:** FBIAS (focus bias) register addition (on/off)  
 The FBIAS register value is added to the signal loaded into the FCS In register by setting D14 to 1 (on).

**FBSS:** FBIAS (focus bias) register/counter switching  
 The FCS BIAS register can be used as a counter by setting D13 to 1 (on).

**FBUP:** FBIAS (focus bias) counter up/down operation switching  
 This performs counter up/down control when FBSS = 1. The FBIAS register functions as a down counter with D12 set to 0, and as an up counter when set to 1.

**FBV1, FBV0:** FBIAS (focus bias) counter voltage switching  
 FCS BIAS count-up steps is decided by these bits.

FBV1	FBV0	Number of steps
0	0	1
0	1	2
1	0	4
1	1	8

The counter changes once for each sampling cycle of the focus servo filter. When MCK is 128Fs, the sampling frequency is 88.2kHz. When converted to FE input, 1 step is approximately 3.9 [mV].

**TJD0:** This sets the tracking servo filter data RAM to 0 when switched from track jump to servo on only when SFJP = 1 (during surf jump operation).

**FPS1, FPS0:** Gain setting when transferring data from the focus filter to the PWM block.

**TPS1, TPS0:** Gain setting when transferring data from the tracking filter to the PWM block.

This is effective for increasing the overall gain in order to widen the servo band. Operation when FPS1, FPS0 (TPS1, TPS0) = 00 is the same as usual (7-bit shift). However, 6dB, 12dB and 18dB can be selected independently for focus (tracking) by setting the relative gain to 0dB when FPS1, FPS0 (TPS1, TPS0) = 00.

FPS1	FPS0	Relative gain
0	0	0dB
0	1	+6dB
1	0	+12dB
1	1	+18dB

TPS1	TPS0	Relative gain
0	0	0dB
0	1	+6dB
1	0	+12dB
1	1	+18dB

**CEIT:** The CE pin input takes over the TE pin input by setting D3 to 1 (on). This means that the registers and filters for TE input are used for CE input.

**SJHD:** This holds the tracking filter output at the value when surf jump starts during surf jump.

**INBK:** When D2 is 0 (off), the brake circuit masks the tracking filter output signal with TRKCNCL which is generated by taking the MIRR signal at the TZC edge. When D2 is set to 1 (on), the tracking filter input is masked instead of the output.

**MT10:** The tracking filter input is masked when the MIRR signal is high by setting D1 to 1 (on).

**\$3B**

D15	D14	D13	D12	D11	D10	D9	D8	D7	D6	D5	D4	D3	D2	D1	D0
SFO2	SFO1	SDF2	SDF1	MAX2	MAX1	SFOX	BTF	D2V2	D2V1	D1V2	D1V1	RINT	0	0	0

SFOX, SFO2, SFO1: FOK slice level

Default value: 011 (313mV)

RFDC input conversion

SFOX	SFO2	SFO1	Slice level
0	0	0	179mV
0	0	1	223
0	1	0	268
0	1	1	313
1	0	0	357
1	0	1	446
1	1	0	536
1	1	1	625

SDF2, SDF1: DFCT slice level  
 Default value: 10 (179mV)  
 RFDC input conversion

SDF2	SDF1	Slice level
0	0	89mV
0	1	134
1	0	179
1	1	224

MAX2, MAX1: DFCT maximum time  
 Default value: 00 (no timer limit)

MAX2	MAX1	DFCT maximum time
0	0	No timer limit
0	1	2.00ms
1	0	2.36
1	1	2.72

BTF: Bottom hold double-speed count-up mode for MIRR signal generation  
 On/off (default: off)  
 On when set to 1.

D2V2, D2V1: Peak hold 2 for DFCT signal generation  
 Count-down speed setting  
 Default value: 01 (0.492V/ms, 44.1kHz)  
 [V/ms] unit items indicate RFDC input conversion; [kHz] unit items indicate the operating frequency of the internal counter.

D2V2	D2V1	Count-down speed	
		[V/ms]	[kHz]
0	0	0.246	22.05
0	1	0.492	44.1
1	0	0.984	88.2
1	1	1.969	176.4

D1V2, D1V1: Peak hold 1 for DFCT signal generation  
 Count-down speed setting  
 Default value: 01 (3.938V/ms, 352.8kHz)  
 [V/ms] unit items indicate RFDC input conversion; [kHz] unit items indicate the operating frequency of the internal counter.

D1V2	D1V1	Count-down speed	
		[V/ms]	[kHz]
0	0	1.969	176.4
0	1	3.938	352.8
1	0	7.875	705.6
1	1	15.75	1411.2

RINT: This initializes the initial-stage registers of the circuits which generate MIRR, DFCT and FOK.

**\$3E**

D15	D14	D13	D12	D11	D10	D9	D8	D7	D6	D5	D4	D3	D2	D1	D0
F1NM	F1DM	F3NM	F3DM	T1NM	T1UM	T3NM	T3UM	DFIS	TLCD	RFLP	0	0	0	MIRI	XT1D

F1NM, F1DM: Quasi double accuracy setting for FCS servo filter first-stage

On when set to 1; default = 0.

F1NM: Gain normal

F1DM: Gain down

T1NM, T1UM: Quasi double accuracy setting for TRK servo filter first-stage

On when set to 1; default = 0.

T1NM: Gain normal

T1UM: Gain up

F3NM, F3DM: Quasi double accuracy setting for FCS servo filter third-stage

On when set to 1; default = 0.

Generally, the advance amount of the phase becomes large by partially setting the FCS servo third-stage filter which is used as the phase compensation filter to double accuracy.

F3NM: Gain normal

F3DM: Gain down

T3NM, T3UM: Quasi double accuracy setting for TRK servo filter third-stage

On when set to 1; default = 0.

Generally, the advance amount of the phase becomes large by partially setting the TRK servo third-stage filter which is used as the phase compensation filter to double accuracy.

T3NM: Gain normal

T3UM: Gain up

**Note)** Filter first- and third-stage quasi double accuracy settings can be set individually.

See "FILTER Composition" at the end of this specification concerning quasi double-accuracy.

DFIS: FCS hold filter input extraction node selection

0: M05 (Data RAM address 05); default

1: M04 (data RAM address 04)

TLCD: This command masks the TLC2 command set by D2 of \$38 only when FOK is low.

On when set to 1; default = 0

RFLP: This command passes the signal obtained from the RFDC pin through the LPF (low-pass filter) before the built-in A/D converter.

0: LPF off; default

1: LPF on

MIRI: MIRR input switching.

The MIRR signal can be input from an external source. When D1 is 0, the MIRR signal is used internally as usual. When D1 = 1, the MIRR signal can be input from an external source through the MIRR pin.

XT1D: The clock input from FSTI can be used as the master clock for the servo block regardless of the XTSL pin, XT2D and XT4D by setting D0 to 1.

**\$3F**

D15	D14	D13	D12	D11	D10	D9	D8	D7	D6	D5	D4	D3	D2	D1	D0
0	AGG4	XT4D	XT2D	0	DRR2	DRR1	DRR0	0	ASFG	0	LPAS	SRO1	SRO0	AGHF	COT2

**AGG4:** This varies the amplitude of the internally generated sine wave using the AGGF and AGGT commands during AGC.  
When AGG4 = 0, the default is used. When AGG4 = 1, the setting is as shown in the table below.

AGGF (MSB)	AGGT (LSB)	TE/FE input conversion
0	0	31 [mV]
0	1	63 [mV]
1	0	125 [mV]
1	1	250 [mV]

These settings are the same as for both focus auto gain control and tracking auto gain control.

**XT4D, XT2D:** MCK (digital servo master clock) frequency division setting  
This command forcibly sets the frequency division ratio to 1/2 or 1/4 when MCK is generated from the signal input to the FSTI pin.

XT4D	XT2D	Frequency division ratio
0	0	According to XTSL (default)
0	1	1/2
1	0	1/4

**DRR2 to DRR0:** Partially clears the Data RAM values (0 write).  
The following values are cleared when set to 1 (on) respectively; default = 0  
DRR2: M08, M09, M0A  
DRR1: M00, M01, M02  
DRR0: M00, M01, M02 only when LOCK = low  
**Note)** Set DRR1 and DRR0 for 50µs or more.

**ASFG:** When vibration detection is performed during anti-shock circuit operation, FCS servo filter is forcibly set to gain normal status.  
On when set to 1; default = 0

**LPAS:** Built-in analog buffer low-current consumption mode  
This mode reduces the total analog buffer current consumption for the VC, TE, SE and FE input by using a single operational amplifier.  
On when set to 1; default = 0  
**Note)** When using this mode, firstly check whether each error signal is properly A/D converted using the SRO1 and SRO0 commands of \$3F.

**SRO1, SRO0:** These commands are used to output various data continuously externally which have been specified with the \$39 command. (However, D15 (DAC) of \$39 must be set to 1.)  
Digital output (SOCK, XOLT and SOUT) can be obtained from three specified pins by setting these commands to 1 respectively. The default is 0, 0.

The output pins for each case are shown below.

	SRO1 = 1
SOCK	XUGF
XOLT	GFS
SOUT	GTOP

(See "Description of Data Readout" on the following page.)

**AGHF:** This halves the frequency of the internally generated sine wave during AGC.  
**COT2:** The STZC signal is output from COUT by setting D0 to 1.  
(STZC: TZC signal generated by sampling the TE signal at 700kHz)

**Description of Data Readout**

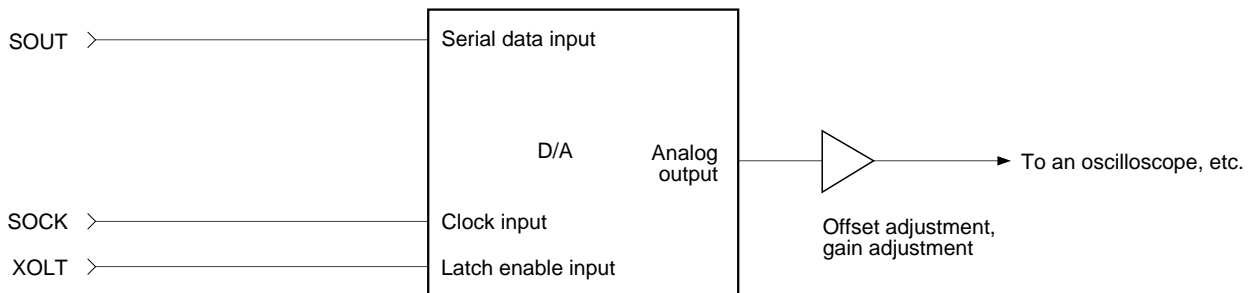
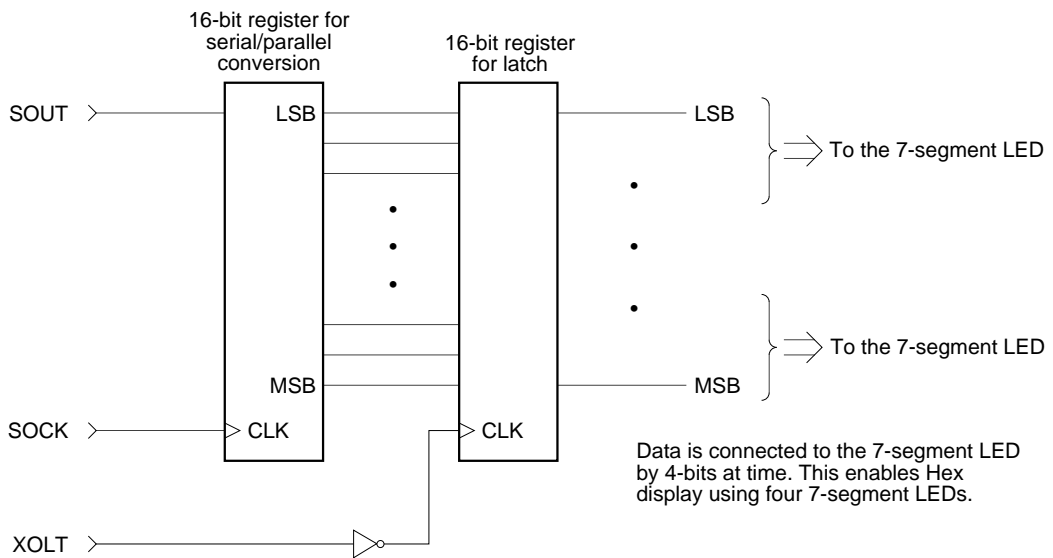
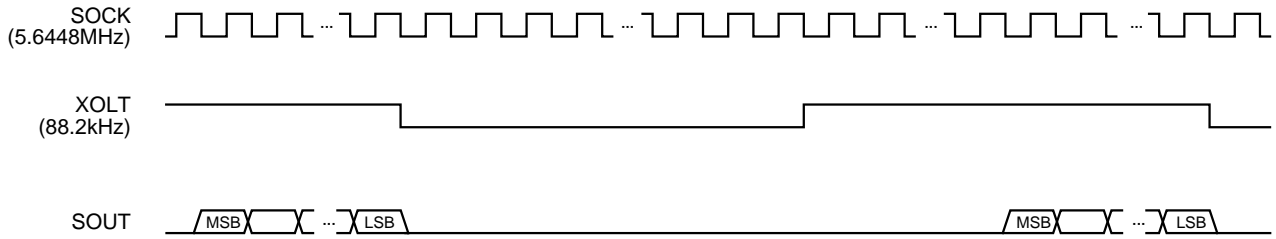

Waveforms can be monitored with an oscilloscope using a serial input-type D/A converter as shown above.

## §4-19. List of Servo Filter Coefficients

## &lt;Coefficient Preset Value Table (1)&gt;

ADDRESS	DATA	CONTENTS
K00	E0	SLED INPUT GAIN
K01	81	SLED LOW BOOST FILTER A-H
K02	23	SLED LOW BOOST FILTER A-L
K03	7F	SLED LOW BOOST FILTER B-H
K04	6A	SLED LOW BOOST FILTER B-L
K05	10	SLED OUTPUT GAIN
K06	14	FOCUS INPUT GAIN
K07	30	SLED AUTO GAIN
K08	7F	FOCUS HIGH CUT FILTER A
K09	46	FOCUS HIGH CUT FILTER B
K0A	81	FOCUS LOW BOOST FILTER A-H
K0B	1C	FOCUS LOW BOOST FILTER A-L
K0C	7F	FOCUS LOW BOOST FILTER B-H
K0D	58	FOCUS LOW BOOST FILTER B-L
K0E	82	FOCUS PHASE COMPENSATE FILTER A
K0F	7F	FOCUS DEFECT HOLD GAIN
K10	4E	FOCUS PHASE COMPENSATE FILTER B
K11	32	FOCUS OUTPUT GAIN
K12	20	ANTI SHOCK INPUT GAIN
K13	30	FOCUS AUTO GAIN
K14	80	HPTZC / Auto Gain HIGH PASS FILTER A
K15	77	HPTZC / Auto Gain HIGH PASS FILTER B
K16	80	ANTI SHOCK HIGH PASS FILTER A
K17	77	HPTZC / Auto Gain LOW PASS FILTER B
K18	00	Fix*
K19	F1	TRACKING INPUT GAIN
K1A	7F	TRACKING HIGH CUT FILTER A
K1B	3B	TRACKING HIGH CUT FILTER B
K1C	81	TRACKING LOW BOOST FILTER A-H
K1D	44	TRACKING LOW BOOST FILTER A-L
K1E	7F	TRACKING LOW BOOST FILTER B-H
K1F	5E	TRACKING LOW BOOST FILTER B-L
K20	82	TRACKING PHASE COMPENSATE FILTER A
K21	44	TRACKING PHASE COMPENSATE FILTER B
K22	18	TRACKING OUTPUT GAIN
K23	30	TRACKING AUTO GAIN
K24	7F	FOCUS GAIN DOWN HIGH CUT FILTER A
K25	46	FOCUS GAIN DOWN HIGH CUT FILTER B
K26	81	FOCUS GAIN DOWN LOW BOOST FILTER A-H
K27	3A	FOCUS GAIN DOWN LOW BOOST FILTER A-L
K28	7F	FOCUS GAIN DOWN LOW BOOST FILTER B-H
K29	66	FOCUS GAIN DOWN LOW BOOST FILTER B-L
K2A	82	FOCUS GAIN DOWN PHASE COMPENSATE FILTER A
K2B	44	FOCUS GAIN DOWN DEFECT HOLD GAIN
K2C	4E	FOCUS GAIN DOWN PHASE COMPENSATE FILTER B
K2D	1B	FOCUS GAIN DOWN OUTPUT GAIN
K2E	00	NOT USED
K2F	00	NOT USED

&lt;Coefficient ROM Preset Value Table (2)&gt;

ADDRESS	DATA	CONTENTS
K30	80	Fix*
K31	66	ANTI SHOCK LOW PASS FILTER B
K32	00	NOT USED
K33	7F	ANTI SHOCK HIGH PASS FILTER B-H
K34	6E	ANTI SHOCK HIGH PASS FILTER B-L
K35	20	ANTI SHOCK FILTER COMPARATE GAIN
K36	7F	TRACKING GAIN UP2 HIGH CUT FILTER A
K37	3B	TRACKING GAIN UP2 HIGH CUT FILTER B
K38	80	TRACKING GAIN UP2 LOW BOOST FILTER A-H
K39	44	TRACKING GAIN UP2 LOW BOOST FILTER A-L
K3A	7F	TRACKING GAIN UP2 LOW BOOST FILTER B-H
K3B	77	TRACKING GAIN UP2 LOW BOOST FILTER B-L
K3C	86	TRACKING GAIN UP PHASE COMPENSATE FILTER A
K3D	0D	TRACKING GAIN UP PHASE COMPENSATE FILTER B
K3E	57	TRACKING GAIN UP OUTPUT GAIN
K3F	00	NOT USED
K40	04	TRACKING HOLD FILTER INPUT GAIN
K41	7F	TRACKING HOLD FILTER A-H
K42	7F	TRACKING HOLD FILTER A-L
K43	79	TRACKING HOLD FILTER B-H
K44	17	TRACKING HOLD FILTER B-L
K45	6D	TRACKING HOLD FILTER OUTPUT GAIN
K46	00	NOT USED
K47	00	NOT USED
K48	02	FOCUS HOLD FILTER INPUT GAIN
K49	7F	FOCUS HOLD FILTER A-H
K4A	7F	FOCUS HOLD FILTER A-L
K4B	79	FOCUS HOLD FILTER B-H
K4C	17	FOCUS HOLD FILTER B-L
K4D	54	FOCUS HOLD FILTER OUTPUT GAIN
K4E	00	NOT USED
K4F	00	NOT USED

\* Fix indicates that normal preset values should be used.

§4-20. FILTER Composition

The internal filter composition is shown below.

K \*\* and M \*\* indicate coefficient RAM and Data RAM address values respectively.

FCS Servo Gain Normal  $f_s = 88.2\text{kHz}$

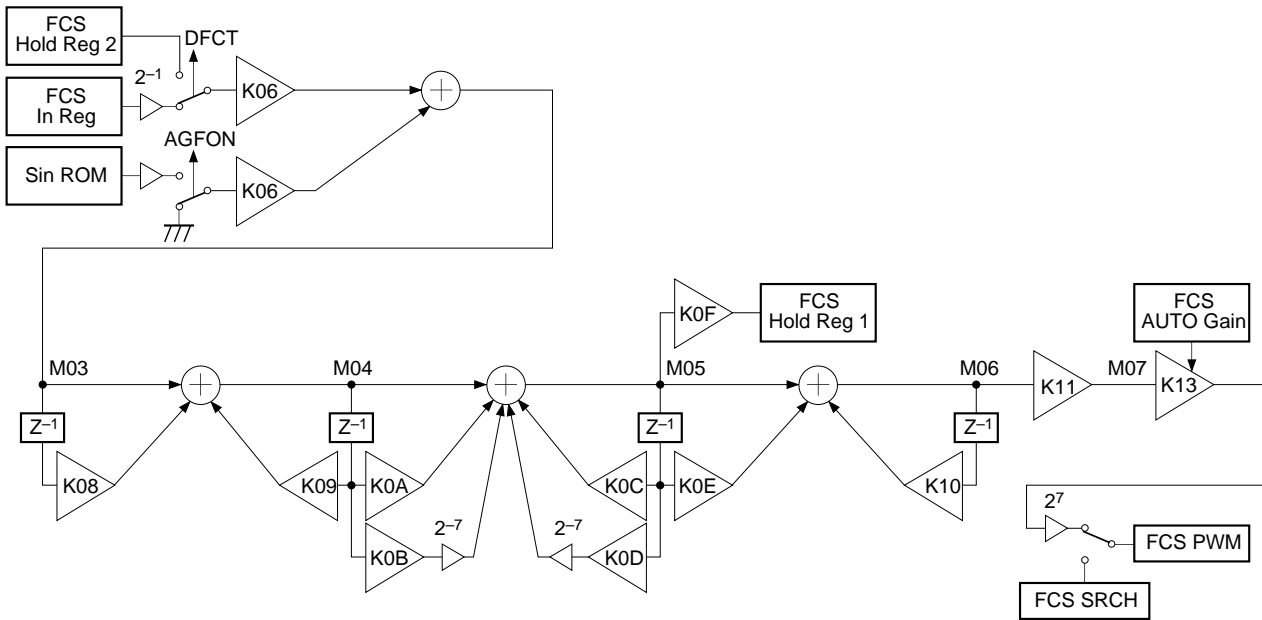

Note) Set the MSB bit of the K0B and K0D coefficients to 0.

FCS Servo Gain Down  $f_s = 88.2\text{kHz}$

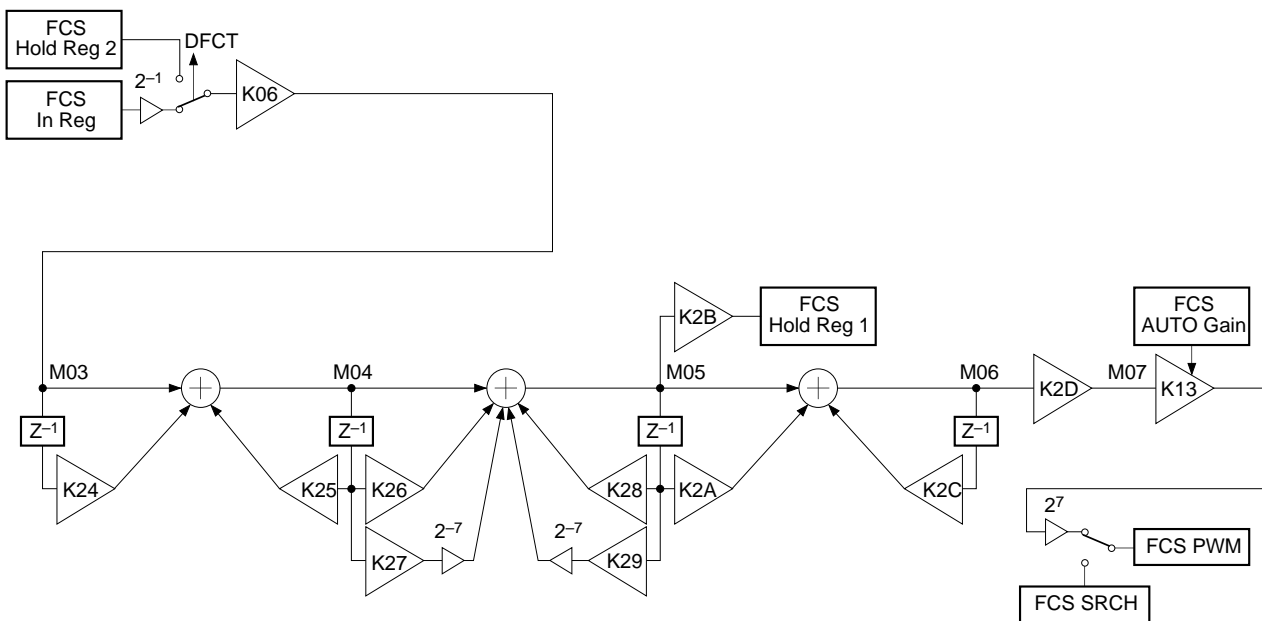

Note) Set the MSB bit of the K27 and K29 coefficients to 0.

**TRK Servo Gain Normal fs = 88.2kHz**

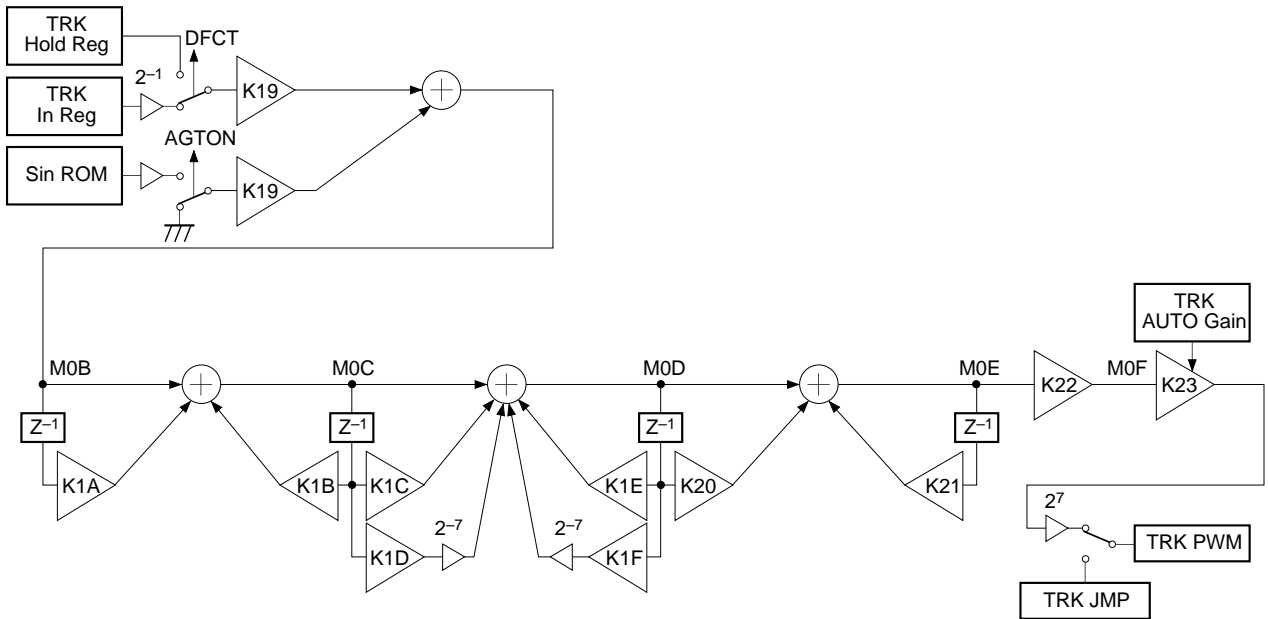

Note) Set the MSB bit of the K1D and K1F coefficients to 0.

**TRK Servo Gain Up 1 fs = 88.2kHz**

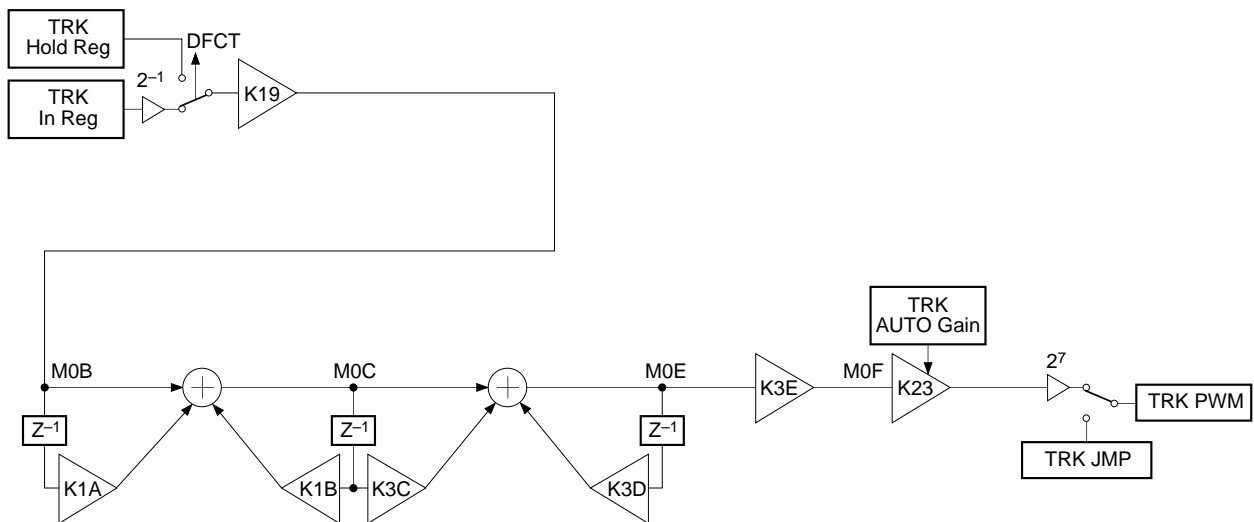

TRK Servo Gain Up 2 fs = 88.2kHz

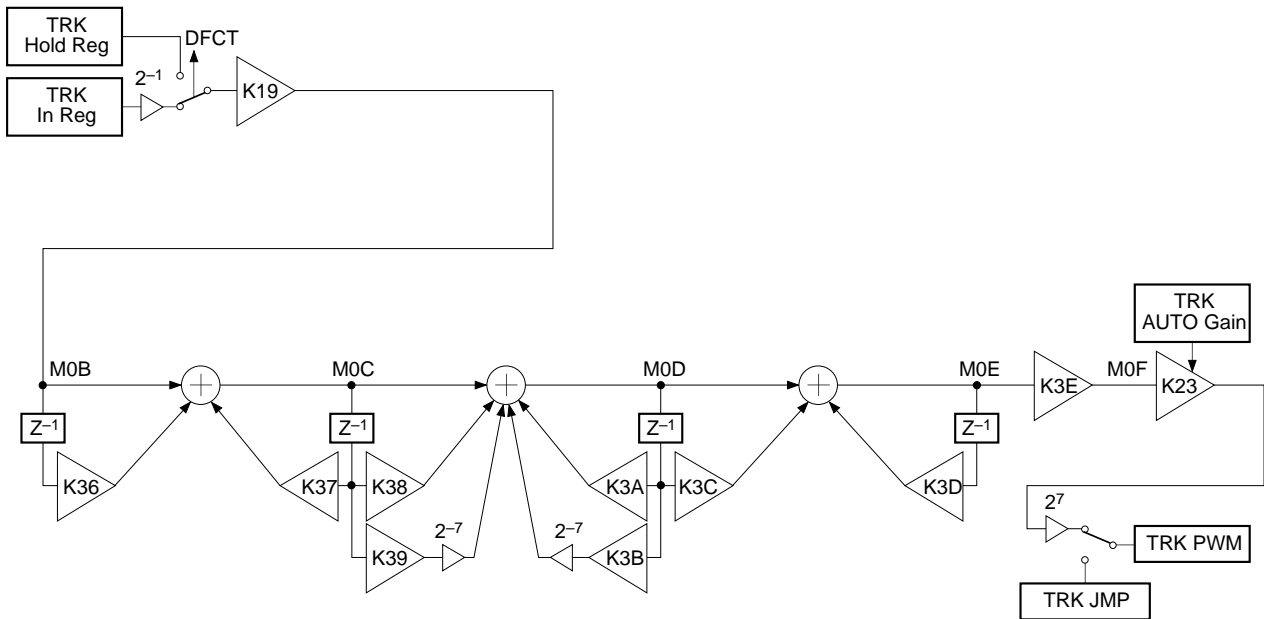

Note) Set the MSB bit of the K39 and K3B coefficients to 0.

SLD Servo fs = 345Hz

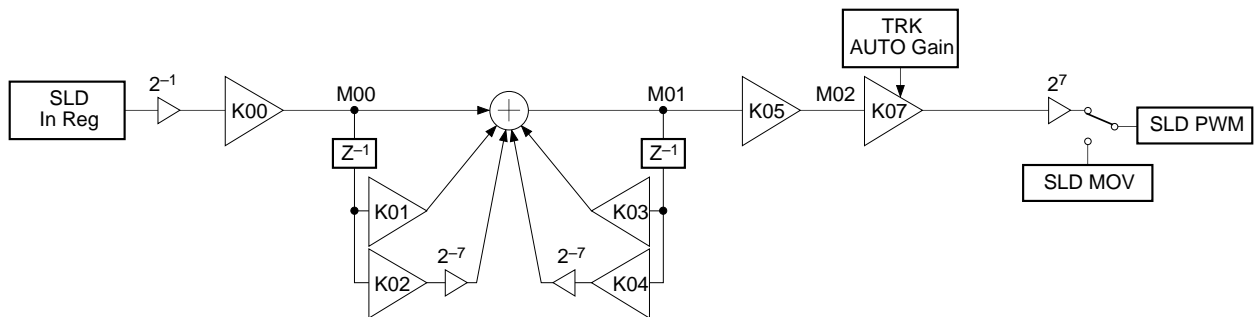

Note) Set the MSB bit of the K02 and K04 coefficients to 0.

HPTZC/Auto Gain fs = 88.2kHz

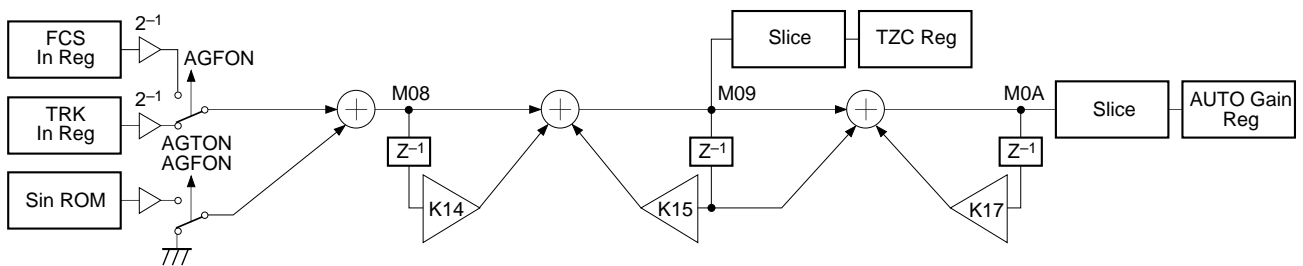

**Anti Shock fs = 88.2kHz**

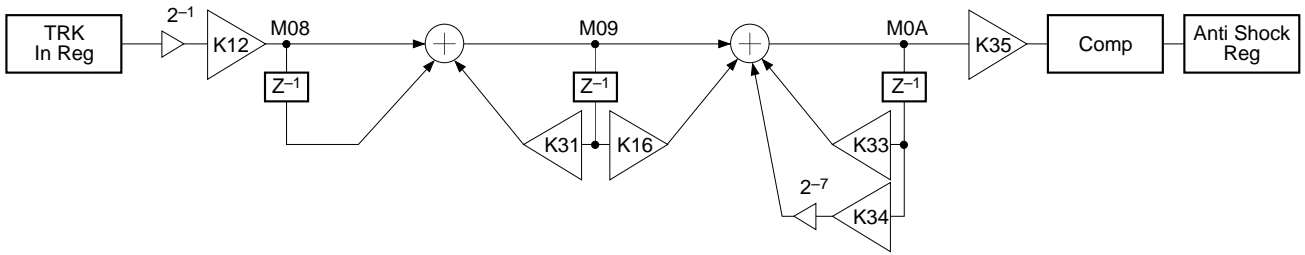

Note) Set the MSB bit of the K34 coefficient to 0.  
The comparator level is 1/16 the maximum amplitude of the comparator input.

**AVRG fs = 88.2kHz**

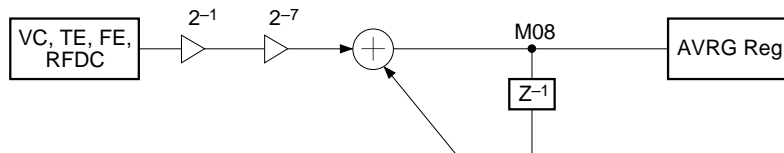

**TRK Hold fs = 345Hz**

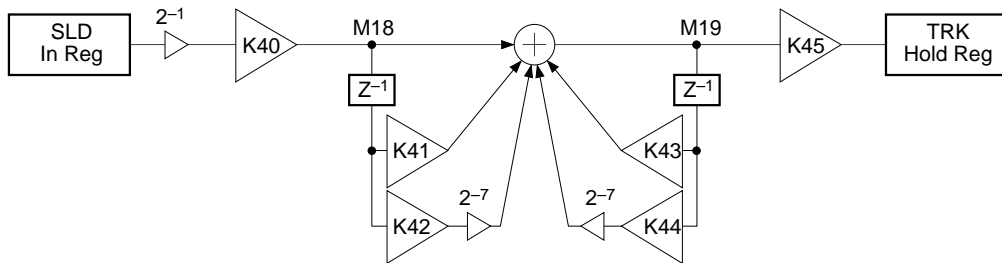

Note) Set the MSB bit of the K42 and K44 coefficients to 0.

**FCS Hold fs = 345Hz**

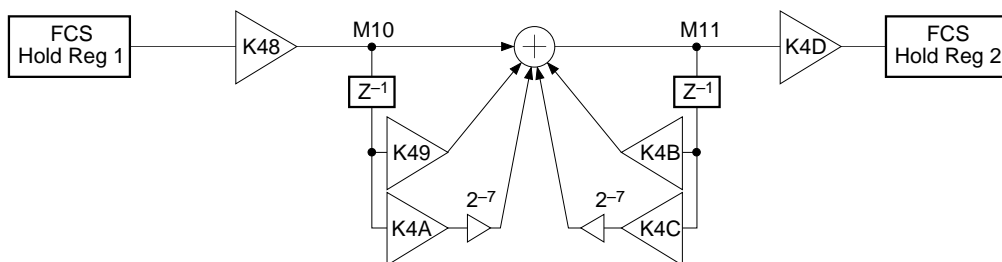

Note) Set the MSB bit of the K4A and K4C coefficients to 0.

**FCS Servo Gain Normal; fs = 88.2kHz, during quasi double accuracy (Ex.: \$3EAXX0)**

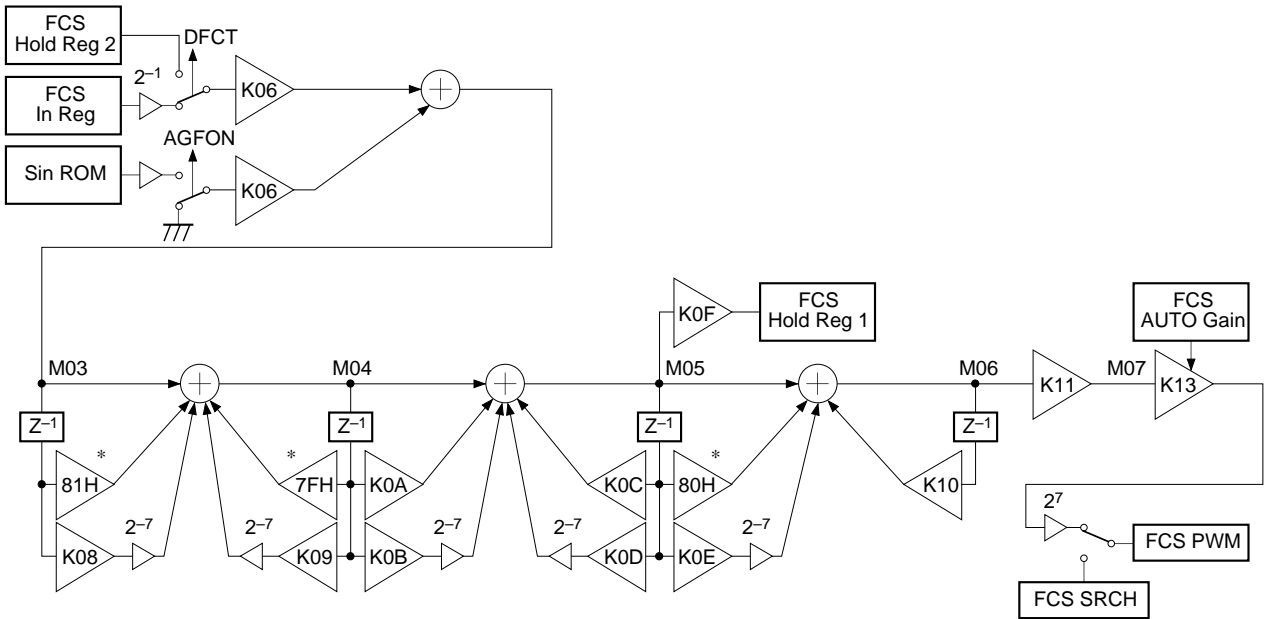

\* 81H, 7FH and 80H are each Hex display 8-bit fixed values when set to quasi double accuracy.

Note) Set the MSB bit of the K0B and K0D coefficients during normal operation, and of the K08, K09 and K0E coefficients during quasi double accuracy to 0.

**FCS Servo Gain Down; fs = 88.2kHz, during quasi double accuracy (Ex.: \$3E5XX0)**

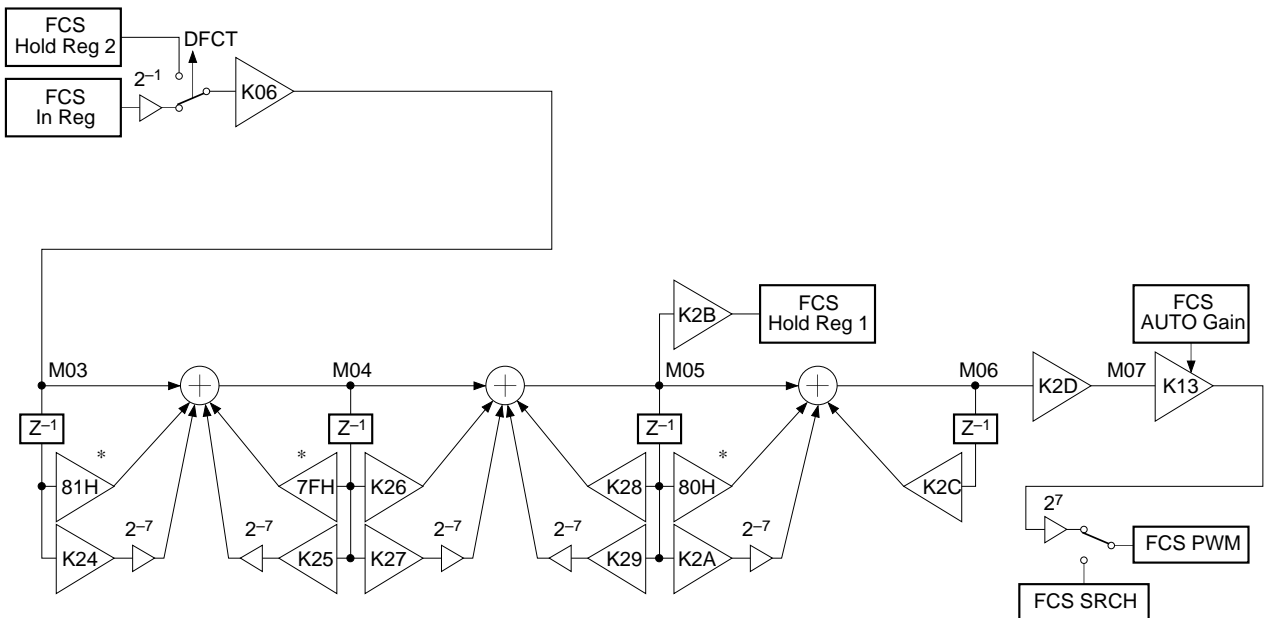

\* 81H, 7FH and 80H are each Hex display 8-bit fixed values when set to quasi double accuracy.

Note) Set the MSB bit of the K27 and K29 coefficients during normal operation, and of the K24, K25 and K2A coefficients during quasi double accuracy to 0.

**TRK Servo Gain Normal;  $f_s = 88.2\text{kHz}$ , during quasi double accuracy (Ex.: \$3EXAX0)**

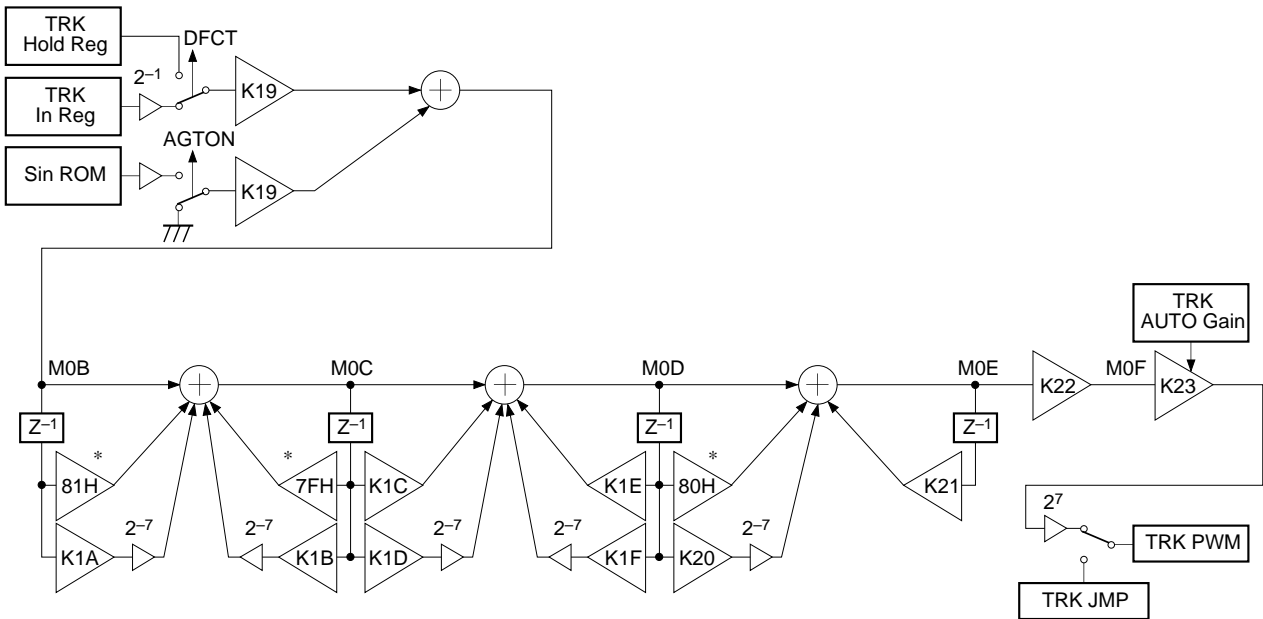

\* 81H, 7FH and 80H are each Hex display 8-bit fixed values when set to quasi double accuracy.

Note) Set the MSB bit of the K1D and K1F coefficients during normal operation, and of the K1A, K1B and K20 coefficients during quasi double accuracy to 0.

**TRK Servo Gain up 1;  $f_s = 88.2\text{kHz}$ , during quasi double accuracy (Ex.: \$3EX5X0)**

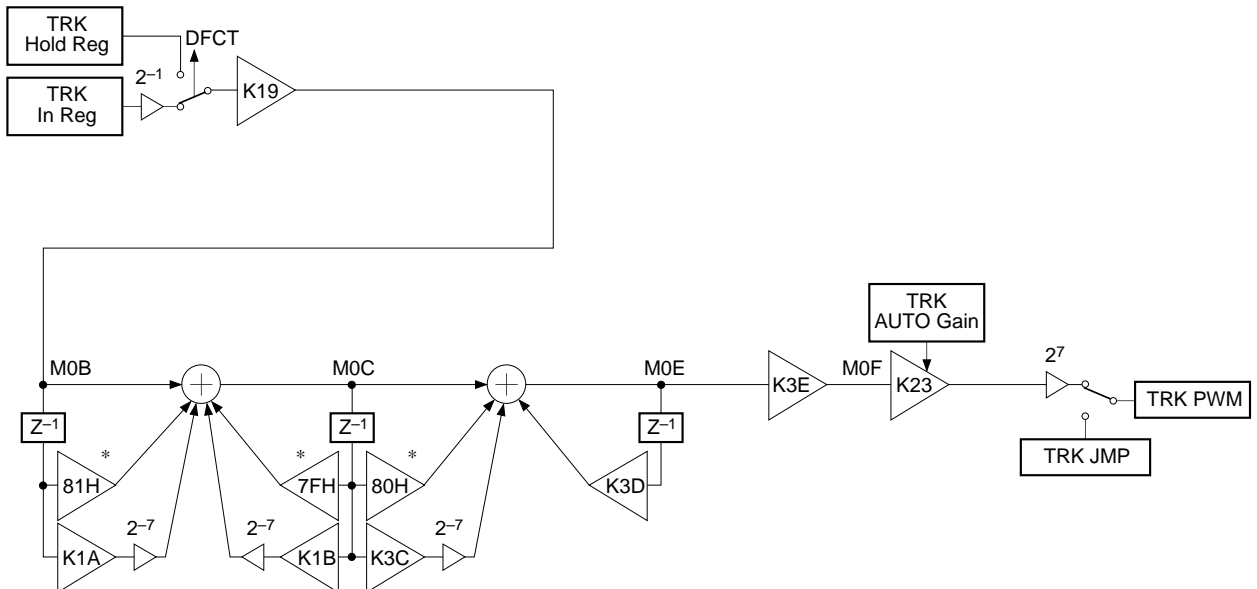

\* 81H, 7FH and 80H are each Hex display 8-bit fixed values when set to quasi double accuracy.

Note) Set the MSB bit of the K1A, K1B and K3C coefficients during quasi double accuracy to 0.

TRK Servo Gain up 2; fs = 88.2kHz, during quasi double accuracy (Ex.: \$3EX5X0)

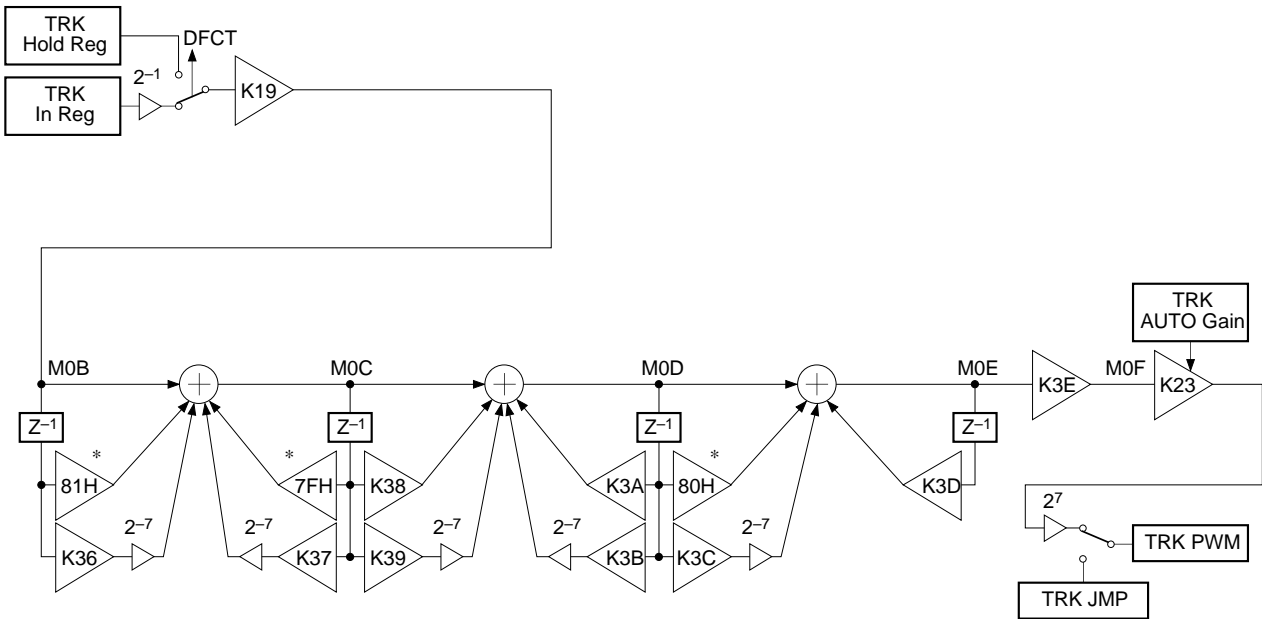

\* 81H, 7FH and 80H are each Hex display 8-bit fixed values when set to quasi double accuracy.

Note) Set the MSB bit of the K39 and K3B coefficients during normal operation, and the K36, K37 and K3C coefficients during quasi double accuracy to 0.

§4-21. TRACKING and FOCUS Frequency Response

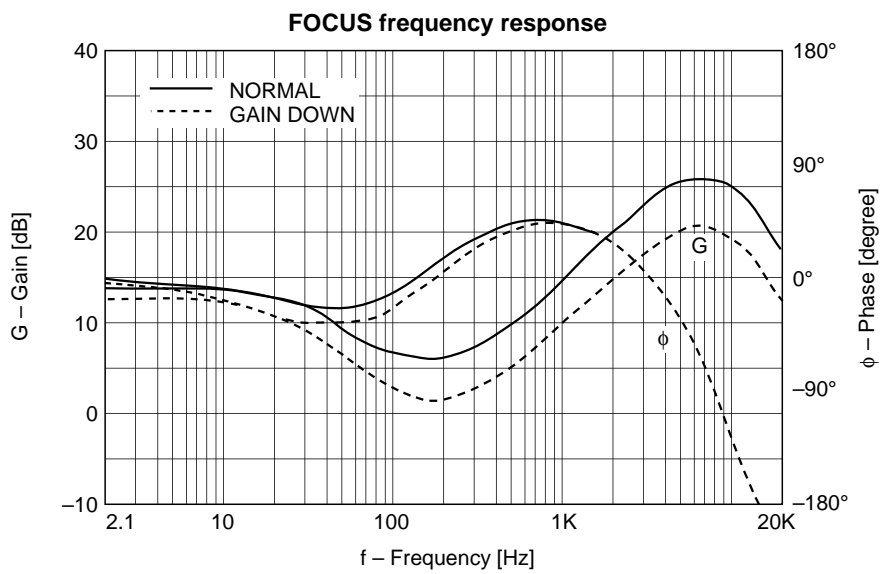
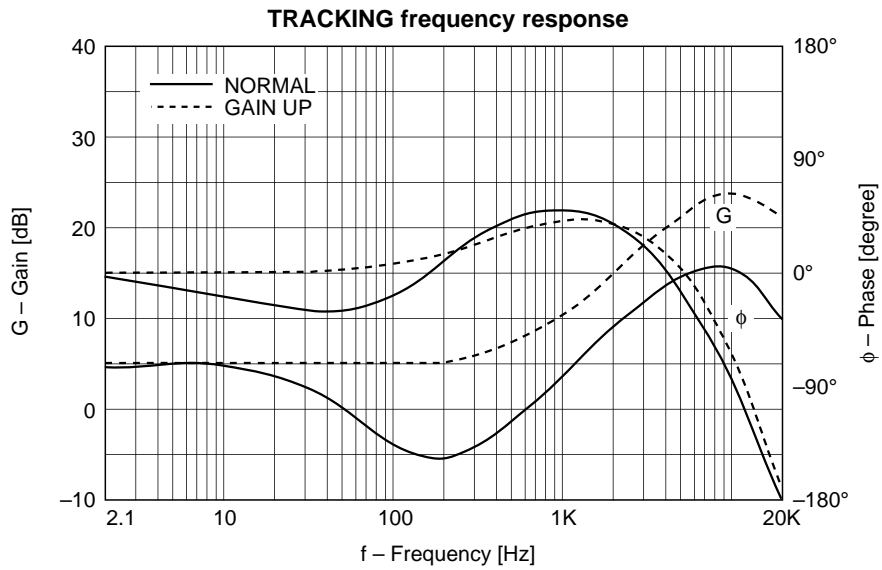



Package Outline

Unit: mm

112PIN LQFP(PLASTIC)

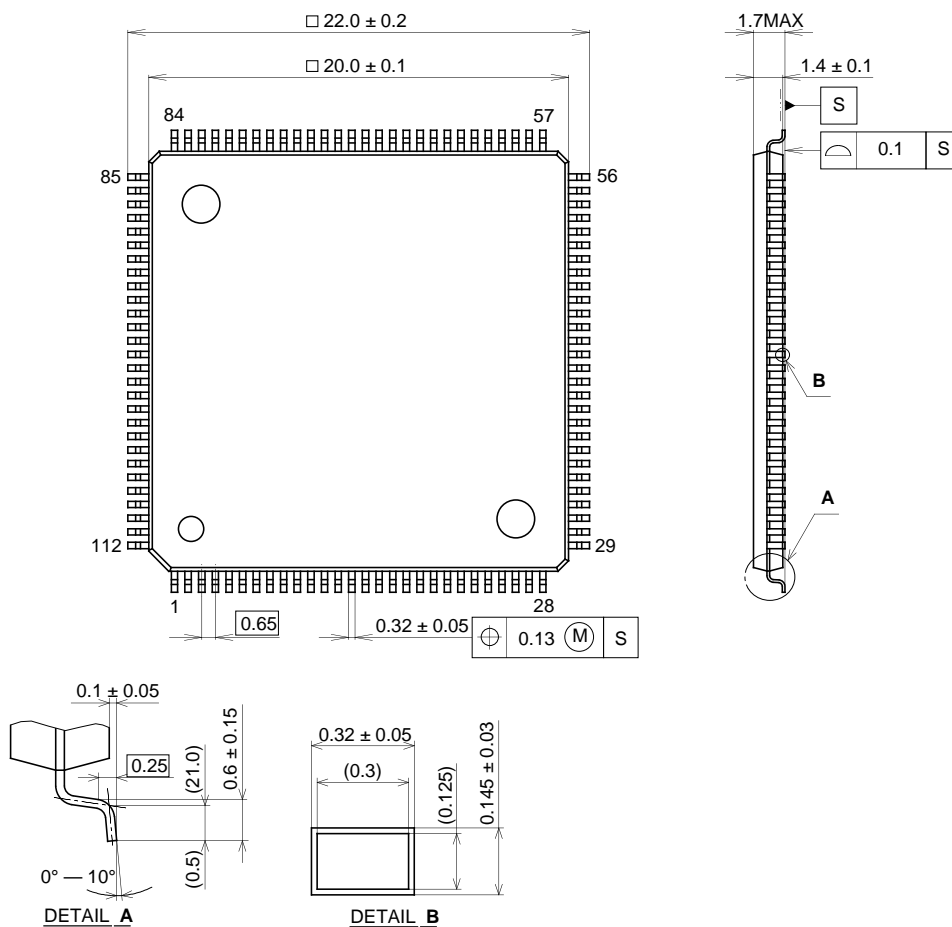

SONY CODE	LQFP-112P-L01
EIAJ CODE	LQFP112-P-2020
JEDEC CODE	—

PACKAGE STRUCTURE

PACKAGE MATERIAL	EPOXY RESIN
LEAD TREATMENT	SOLDER PLATING
LEAD MATERIAL	COPPER ALLOY
PACKAGE WEIGHT	1.3g



LittleDiode supplies new, hard to find or obsolete electronic components and semiconductors all over the world.

With over two million different components listed you are sure to find the part you need.

Feel free to visit us today at our online store:

[LittleDiode.com](http://LittleDiode.com)

Looking forward to providing you with the best possible service.