

CMOS-CCD 1H Delay Line for NTSC

Description

The CXL1504M is a delay line used in conjunction with an external low-pass filter. Through negative phase input and positive phase output 1H delay time is obtained for NTSC signals.

Features

- Single 5V power supply
- 14.3MHz driver
- Low power consumption at 160mW (Typ.)
- Built-in peripheral circuits
- Completely adjustment free

Functions

- 905.5-bit CCD register
- Clock driver
- Autobias circuit
- Input clamp circuit
- Sample and hold circuit

Structure

CMOS-CCD

Absolute Maximum Ratings (Ta = 25°C)

• Supply voltage	V _{DD}	6	V
• Operating temperature	T _{opr}	-10 to +60	°C
• Storage temperature	T _{stg}	-55 to +150	°C
• Allowable power dissipation	P _D	500	mW

Operating Voltage Range (Ta = 25°C)

Supply voltage	V _{DD}	5 ± 5%	V
----------------	-----------------	--------	---

Recommended Clock Conditions (Ta = 25°C)

• Input clock amplitude	V _{CLK}	0.3 to 1.0	V _{p-p} (0.5V _{p-p} typ.)
• Clock frequency	f _{CLK}	14.318182	MHz
• Input clock waveform		sine wave	

Input Signal Amplitude

V _{SIG}	560	mV _{p-p} (Max.)
------------------	-----	--------------------------

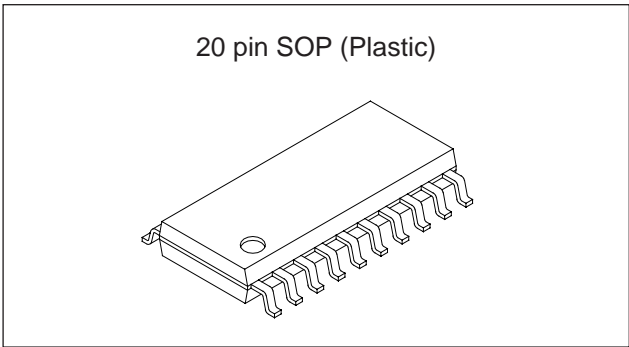

Sony reserves the right to change products and specifications without prior notice. This information does not convey any license by any implication or otherwise under any patents or other right. Application circuits shown, if any, are typical examples illustrating the operation of the devices. Sony cannot assume responsibility for any problems arising out of the use of these circuits.

Block Diagram and Pin Configuration (Top View)

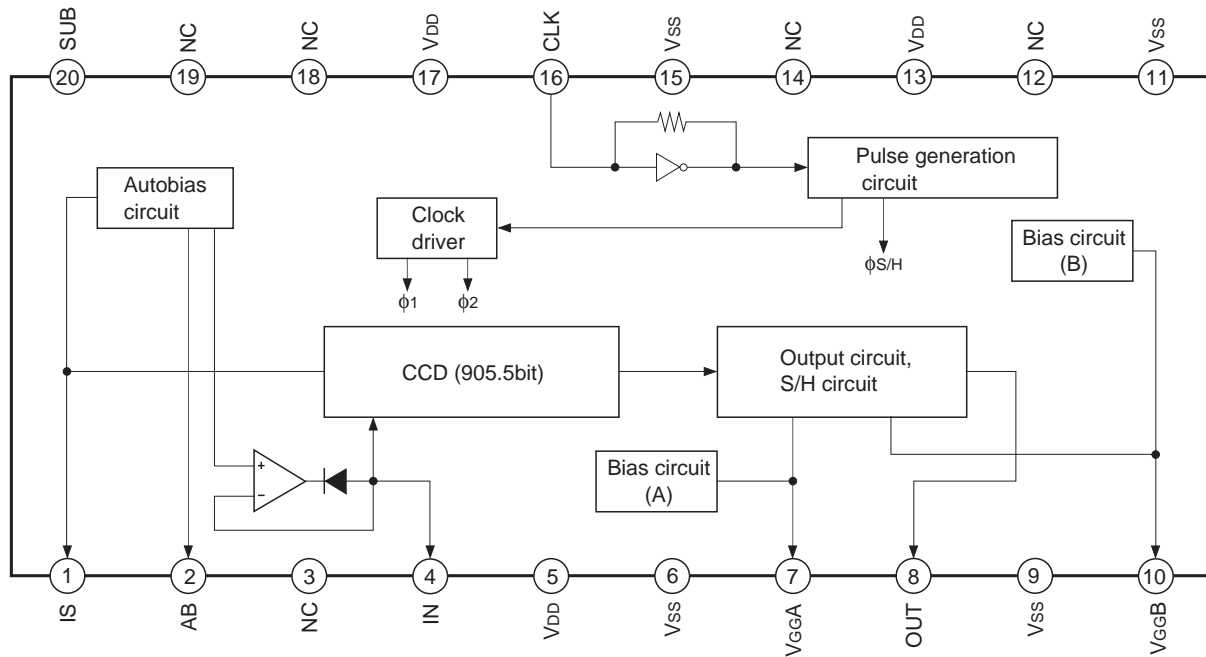

Pin Description

Pin No.	Symbol	I/O	Description	Impedance [Ω]
1	IS	O	CCD bias DC output	600 to 2k
2	AB	O	Autobias DC output	2k to 20k
3	NC	—		
4	IN	I	Signal input (Negative phase signal)	> 100k (at no clamp)
5	V _{DD}	—	5V power supply (For clock driver)	
6	V _{SS}	—	GND	
7	V _{GG} A	O	Gate bias (A) DC output	2k to 10k
8	OUT	O	Signal output (Positive phase signal)	40 to 500
9	V _{SS}	—	GND	
10	V _{GG} B	O	Gate bias (B) DC output	2k to 10k
11	V _{SS}	—	GND	
12	NC	—		
13	V _{DD}	—	5V power supply (For analog system)	
14	NC	—		
15	V _{SS}	—	GND	
16	CLK	I	Clock input	4k to 50k
17	V _{DD}	—	5V power supply (For digital system)	
18	NC	—		
19	NC	—		
20	SUB	—	GND	

Electrical Characteristics

(Ta = 25°C, VDD = 5V, fCLK = 14.318182MHz, VCLK = 500mVp-p, sine wave)

See the Electrical Characteristics Test Circuits.

Item	Symbol	Test conditions	SW conditions				(Note 1) Bias conditions VBIAS1 [V]	Min.	Typ.	Max.	Unit	Note
			1	2	3	4						
Supply current	IDD	—	a	a	a	—	20	32	42	mA	2	
Low frequency gain	GL	200kHz, 500mVp-p, sine wave	a	a	a	b	—	-5.0	-3.0	-1.0	dB	3
Frequency response	fr	200kHz ↔ 3.58MHz, 150mVp-p, sine wave	b ↓ c	a	b	b	VIN - 0.2	-2.5	-1.3	0	dB	4
Differential gain	DG	5-staircase wave (See Note 5)	d	a	a	c	—	0	3	7	%	5
Differential phase	DP	5-staircase wave (See Note 5)	d	a	a	c	—	0	3	7	degree	5
S/H pulse coupling	CP	No signal input	—	b	b	a	VIN	—	200	350	mVp-p	6
S/N ratio	S/N	50% white video signal (See Note 7)	e	a	a	d	—	54	56	—	dB	7

Notes

1) VIN is defined as follows.

VIN is the input signal clamp level, it clamps the video signal sync tip level.

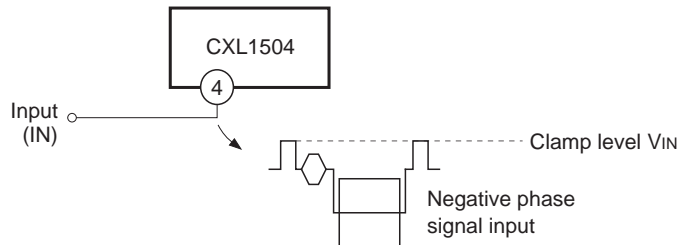

VIN is the pin voltage for Pin 4 at no-input signal. Testing is executed with a voltmeter under the following SW conditions.

Item	SW conditions				Test point
	1	2	3	4	
VIN	—	b	a	—	V1

As VIN varies with each IC, they are all subject to testing.

2) IDD is the IC supply current value during clock and signal input.

3) GL is the OUT pin output gain when a 500mVp-p, 200kHz sine wave is input to IN pin.

$$GL = 20 \log \frac{\text{OUT pin output voltage [mVp-p]}}{500 \text{ [mVp-p]}} \text{ [dB]}$$

4) Indicates the dissipation at 3.58MHz in relation to 200kHz.

From the output voltage at OUT pin when a 150mVp-p, 200kHz sine wave is fed to IN pin, and from the output voltage at OUT pin when a 150mVp-p, 3.58MHz sine wave is fed to same, calculation is made according to the following formula. The input part bias is tested at $V_{IN} - 0.2V$.

$$fr = 20 \log \frac{\text{OUT pin output voltage (3.58MHz) [mVp-p]}}{\text{OUT pin output voltage (200kHz) [mVp-p]}} \text{ [dB]}$$

5) The differential gain (DG) and the differential phase (DP), when the 5-staircase wave in the figure. below is input are tested at the vector scope.

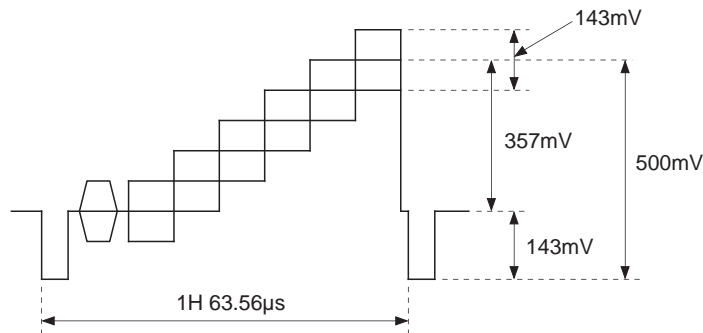

IN pin input waveform is the inverted waveform in the figure above

6) The internal clock component to the output signal during no-signal input and the leakage of that high harmonic component are tested. The input part bias is tested at V_{IN} .

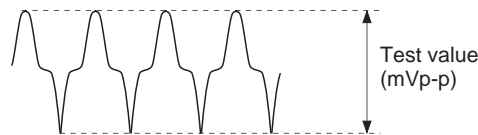

7) S/N ratio during 50% white video signal input shown in figure. below is tested at a video noise meter, in BPF 100kHz to 4MHz, Sub Carrier Trap mode.

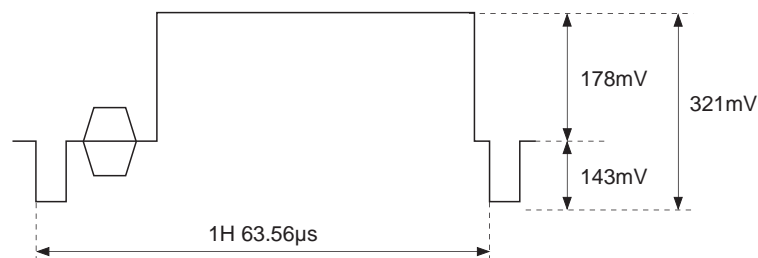

IN pin input waveform is the inverted waveform in the figure above

Clock

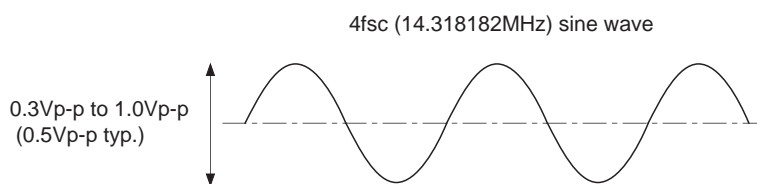

Example of Representative Characteristics

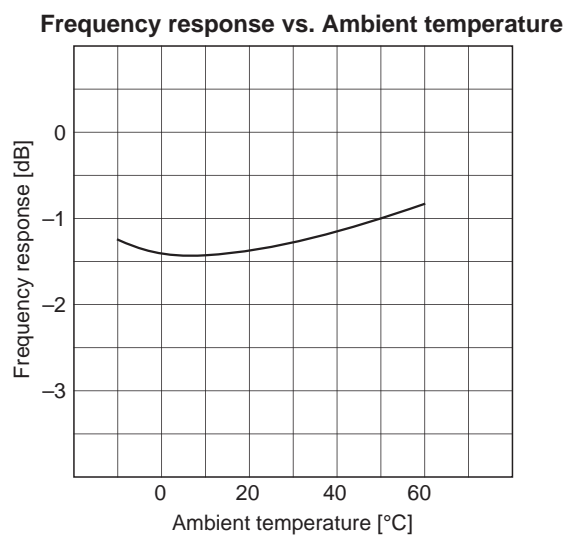
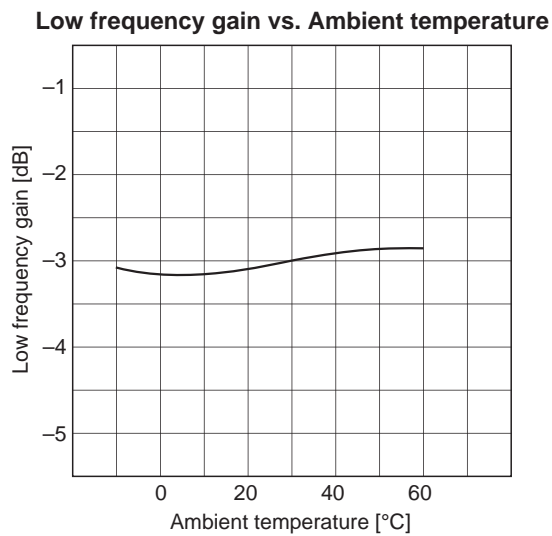
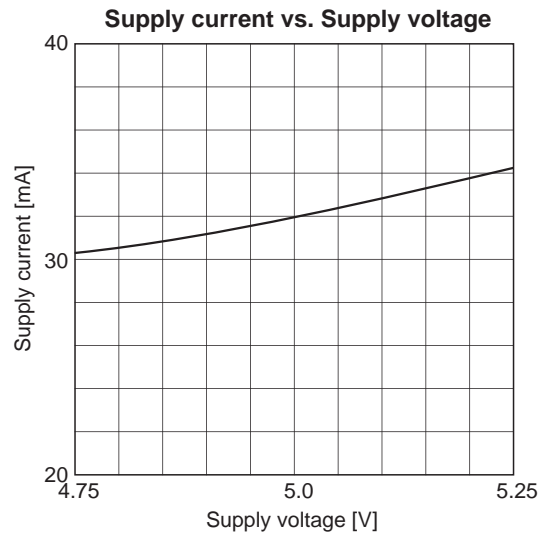
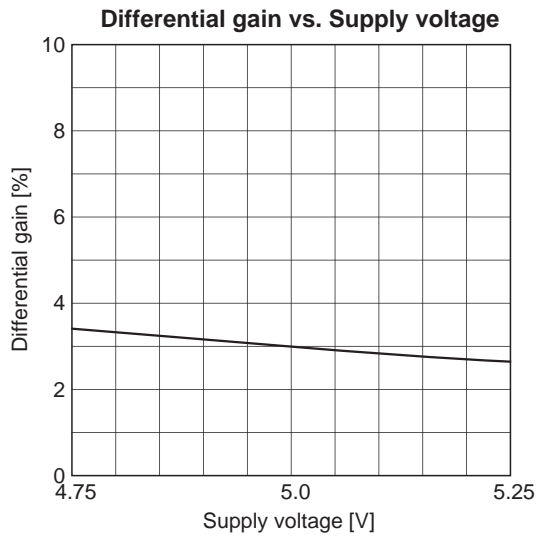
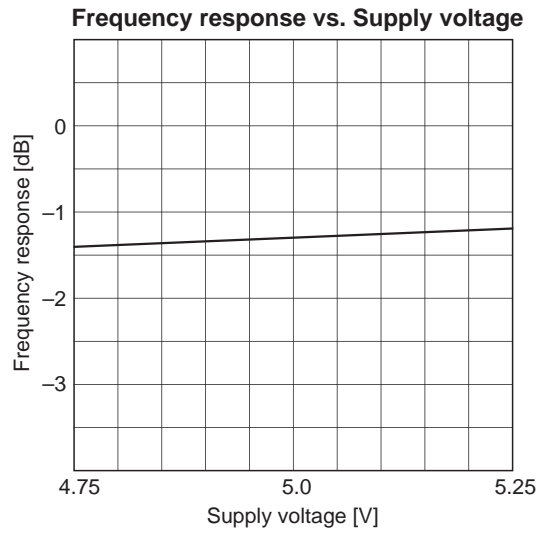
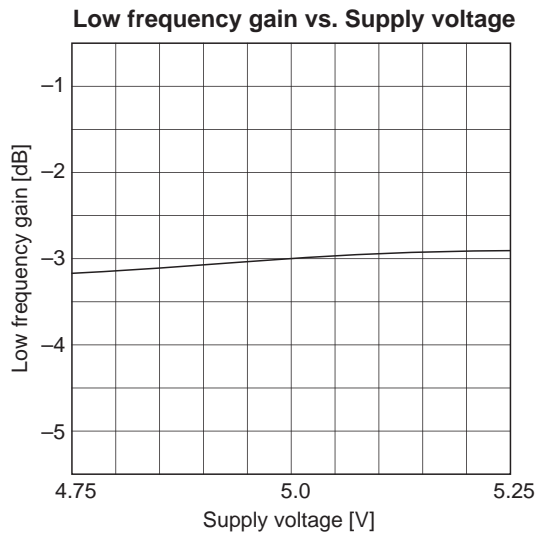

Differential gain vs. Ambient temperature

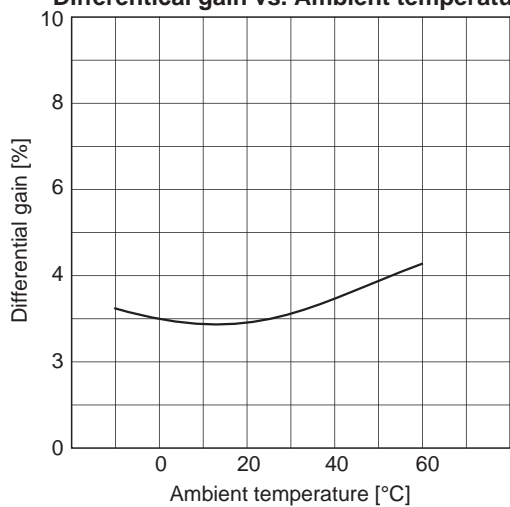

Supply current vs. Ambient temperature

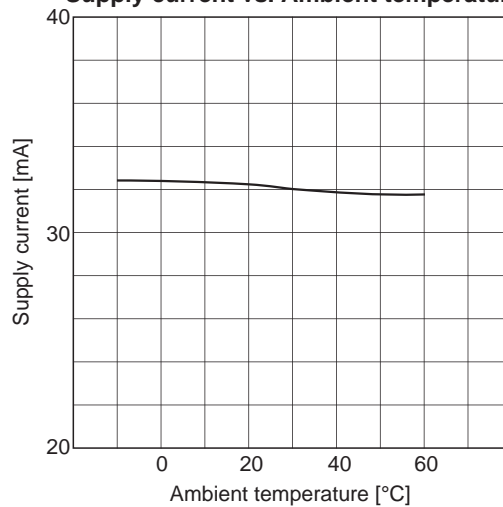

Frequency response

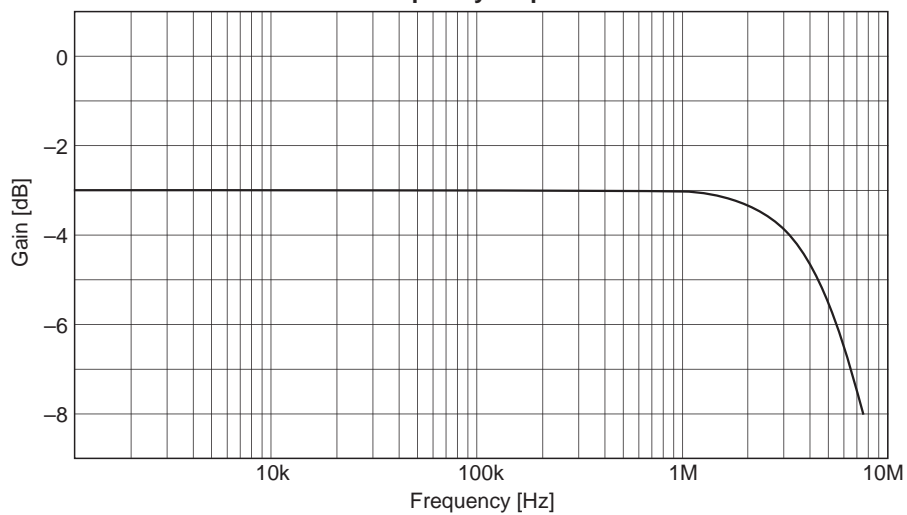

Package Outline Unit: mm

20PIN SOP (PLASTIC)

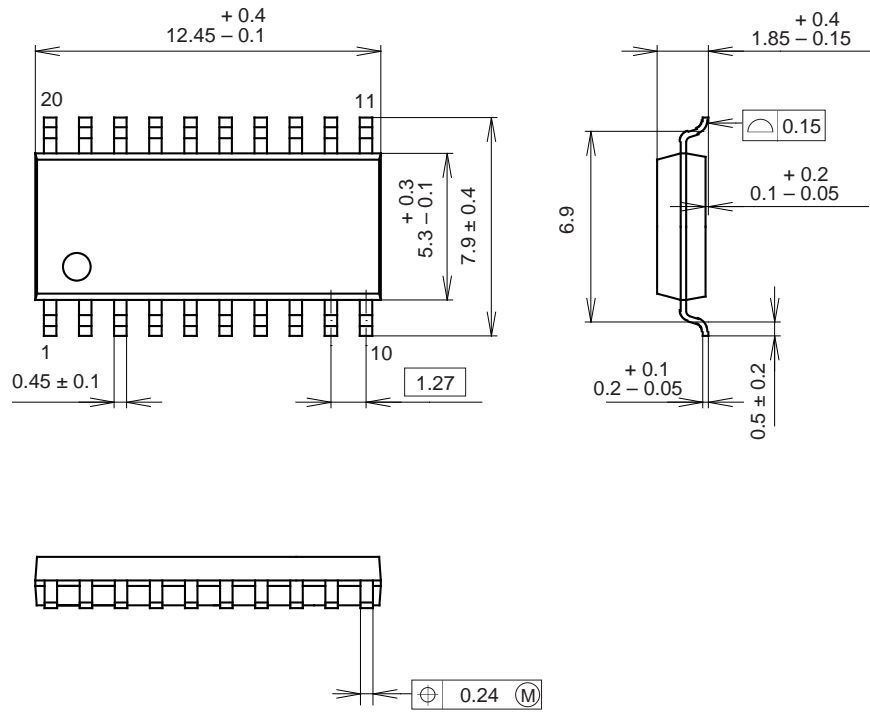

PACKAGE STRUCTURE

SONY CODE	SOP-20P-L01
EIAJ CODE	SOP020-P-0300
JEDEC CODE	_____

PACKAGE MATERIAL	EPOXY RESIN
LEAD TREATMENT	SOLDER PLATING
LEAD MATERIAL	COPPER ALLOY
PACKAGE MASS	0.3g



LittleDiode supplies new, hard to find or obsolete electronic components and semiconductors all over the world.

With over two million different components listed you are sure to find the part you need.

Feel free to visit us today at our online store:

LittleDiode.com

Looking forward to providing you with the best possible service.