

## CMOS-CCD 1H Delay Line for NTSC

**Description**

The CXL5504M/P are CMOS-CCD delay line ICs that provide 1H delay time for NTSC signals including the external low-pass filter.

**Features**

- Single power supply (5V)
- Low power consumption 90mW (Typ.)
- Built-in peripheral circuits
- Clamp level of I/O signal can be selected

**Functions**

- 905-bit CCD register
- Clock driver
- Autobias circuit
- Input clamp circuit
- Sample and hold circuit

**Structure**

CMOS-CCD

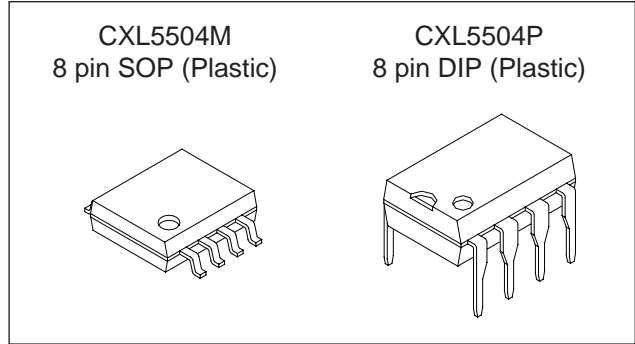

**Absolute Maximum Ratings** (Ta = 25°C)

• Supply voltage	V <sub>DD</sub>	6	V
• Operating temperature	T <sub>opr</sub>	-10 to +60	°C
• Storage temperature	T <sub>stg</sub>	-55 to +150	°C
• Allowable power dissipation	P <sub>D</sub>		
	CXL5504M	350	mW
	CXL5504P	480	mW

**Recommended Operating Condition** (Ta = 25°C)

Supply voltage	V <sub>DD</sub>	5 ± 5%	V
----------------	-----------------	--------	---

**Recommended Clock Conditions** (Ta = 25°C)

- Input clock amplitude V<sub>CLK</sub> 0.4 to 1.0 V<sub>p-p</sub>  
(0.5V<sub>p-p</sub> typ.)
- Clock frequency f<sub>CLK</sub> 14.318182 MHz
- Input clock waveform Sine wave

**Input Signal Amplitude**

V<sub>SIG</sub> 500mV<sub>p-p</sub> (Typ.), 572mV<sub>p-p</sub> (Max.)  
(at internal clamp condition)

**Block Diagram and Pin Configuration (Top View)**

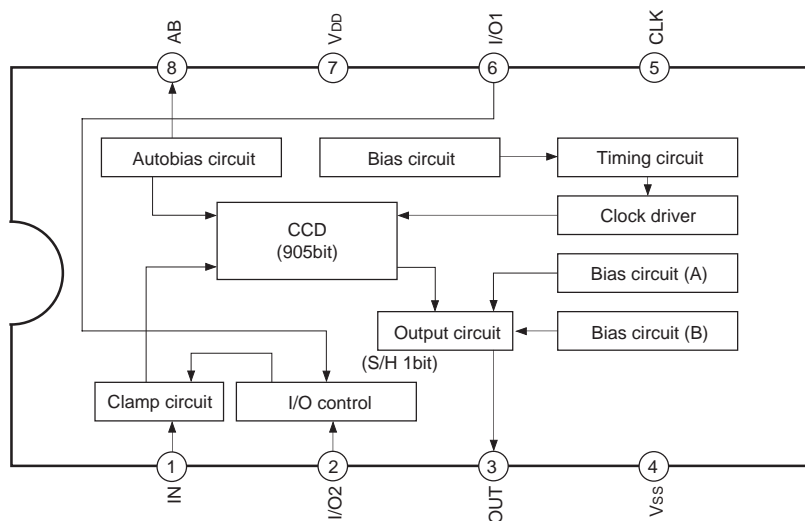

Sony reserves the right to change products and specifications without prior notice. This information does not convey any license by any implication or otherwise under any patents or other right. Application circuits shown, if any, are typical examples illustrating the operation of the devices. Sony cannot assume responsibility for any problems arising out of the use of these circuits.

**Pin Description**

Pin No.	Symbol	I/O	Description	Impedance
1	IN	I	Signal input	> 10kΩ at no clamp
2	I/O2	I	I/O control 2	
3	OUT	O	Signal output	40 to 500Ω
4	V <sub>SS</sub>	—	GND	
5	CLK	I	Clock input	> 100kΩ
6	I/O1	I	I/O control 1	
7	V <sub>DD</sub>	—	Power supply (5V)	
8	AB	O	Autobias DC output	600 to 200kΩ

**Description of Function**

In the CXL5504M/P, the condition of I/O control pins (Pins 2 and 6) control the input signal clamp condition and the mode of the output signal with relation to its input signal.

There are 2 modes for the I/O signal.

- (1) PN mode  
(Low level clamp/reverse phase output mode)
- (2) NP mode  
(High level clamp/positive phase output mode)

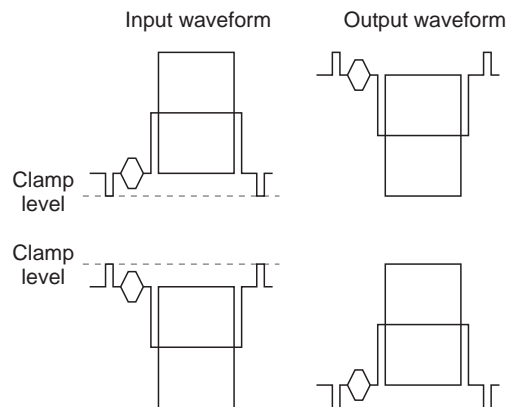

**I/O Control Pin**

(1) I/O1 (Pin 6)

Control of the I/O signal condition

DC open ..... Input signal is low level clamped and the output signal is inverted in relation to the input signal. As the pin is biased to 2.5V by means of the resistance inside the IC, a decoupling capacitor of around 1000pF is necessary.

GND ..... Input signal is high level clamped and the output signal turns into an inverted signal.

(2) I/O2 (Pin 2)

Control of the input signal clamp condition

0V ..... Internal clamp condition

5V ..... Non internal clamp condition

Center biased to approx. 2.1V by means of the IC internal resistance (several 10kΩ).

Usage in this mode is limited to APL 50% signals and in this mode, the maximum input signal amplitude is 200mVp-p.

**Electrical Characteristics** (Ta = 25°C, VDD = 5V, fCLK = 14.318182MHz, VCLK = 500mVp-p, Sine wave)  
See "Electrical Characteristics Test Circuit"

Item	Symbol	Test condition	SW condition							Bias condition Vbias1 (V) (Note 1)	Min.	Typ.	Max.	Unit	Note
			1	2	3	4	5	6	7						
Supply current	IDDPN	—	—	c	b	b	b	a	—	—	10	18	28	mA	2
	IDDNP				a	a									
Low frequency gain	GLPN	200kHz, 500mVp-p, sine wave	a	a	b	b	b	a	b	—	-2	0	2	dB	3
	GLNP				a	a									
Frequency response	fPN	200kHz ↔ 3.57MHz, 150mVp-p, sine wave	b	a	a	b	b	b	b	2.1	-2	-1	0	dB	4
	fNP		↕	c		a	a								
Differential gain	DGPN	5-staircase wave (See Note 5)	d	a	b	b	b	a	c	—	0	5	7	%	5
	DGNP			b		a	a								
Differential phase	DPPN	5-staircase wave (See Note 5)	d	a	b	b	b	a	c	—	0	5	7	degree	5
	DPNP			b		a	a								
S/H pulse coupling	CPPN	No signal input	—	c	a	b	b	b	a	VINPN + 0.5	—	—	350	mVp-p	6
	CPNP					a	a			VINNP					
S/N ratio	SNPN	50% white video signal (See Note 7)	e	a	b	b	b	a	d	—	52	56	—	dB	7
	SNNP			b		a	a								

**Notes**

(1) VINPN and VINNP are defined as follows.

VINPN and VINNP are the input signal clamp levels of PN and NP modes clamping the video signal sync tip level.

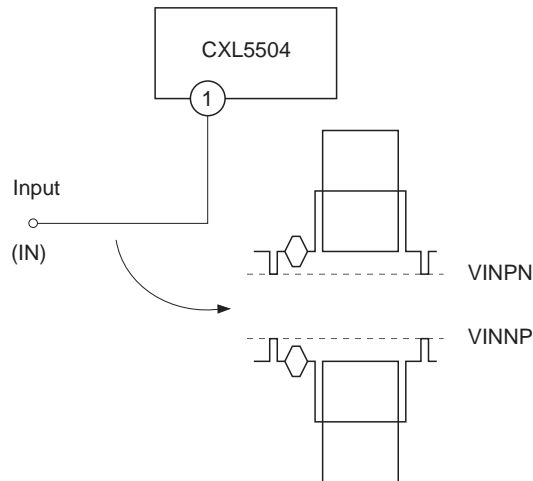

Testing of VINPN and VINNP is executed with a voltmeter under the following SW conditions.

Item	SW condition							Test point
	1	2	3	4	5	6	7	
VINPN	—	c	b	b	b	a	—	V1
VINNP	—	c	b	a	a	a	—	

- (2) This is the IC supply current value during clock and signal input.
- (3) GLPN, GLNP are output gain of OUT pin when a 500mVp-p, 200kHz sine wave is fed to IN pin.  
(Example of calculation)

$$GLPN = 20 \log \frac{\text{OUT pin output voltage (PN mode) [mVp-p]}}{500 \text{ [mVp-p]}} \text{ [dB]}$$

- (4) Indicates the dissipation at 3.57MHz in relation to 200kHz.  
From the output voltage at OUT pin when a 150mVp-p, 200kHz sine wave is fed to IN pin, and from the output voltage at OUT pin when a 150mVp-p, 3.57MHz sine wave is fed to same, calculation is made according to the following formula. The input part bias is tested at 2.1V.  
(Example of calculation)

$$fPN = 20 \log \frac{\text{OUT pin output voltage (PN mode, 3.57MHz) [mVp-p]}}{\text{OUT pin output voltage (PN mode, 200kHz) [mVp-p]}} \text{ [dB]}$$

- (5) The differential gain (DG) and the differential phase (DP), when the 5-staircase wave in the figure below is input are tested at the vector scope.

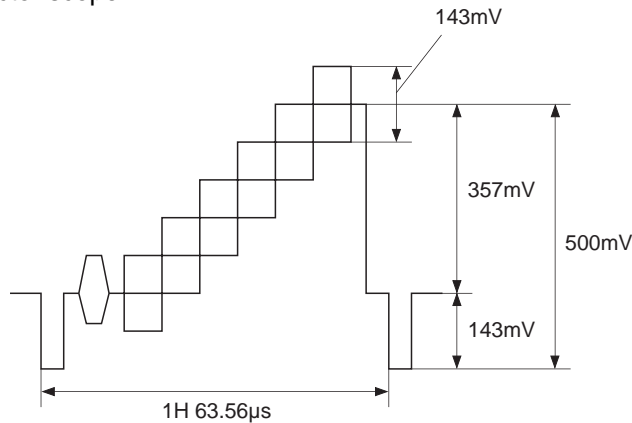

**Input waveform (Input waveform of NP mode is the inverted waveform in the figure above)**

- (6) The internal clock component to the output signal during no-signal input and the leakage of that high harmonic component are tested. The input part bias is tested at VINPN + 0.5V and VINNP for PN and NP modes respectively.

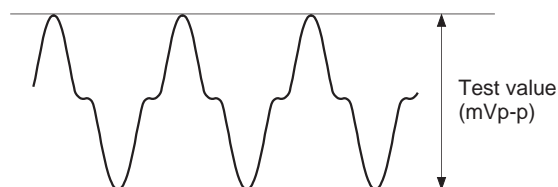

- (7) S/N ratio during a 50% white video signal input shown in figure below is tested at a video noise meter, in BPF 100kHz to 4MHz, Sub Carrier Trap mode.

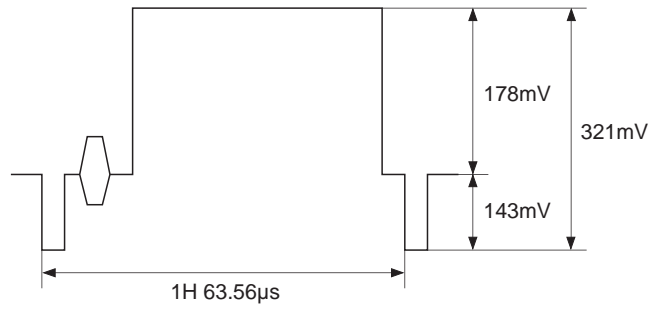

**Input waveform (Input waveform of NP mode is the inverted waveform in the figure above)**

**Clock**

fsc (14.318182MHz) sine wave

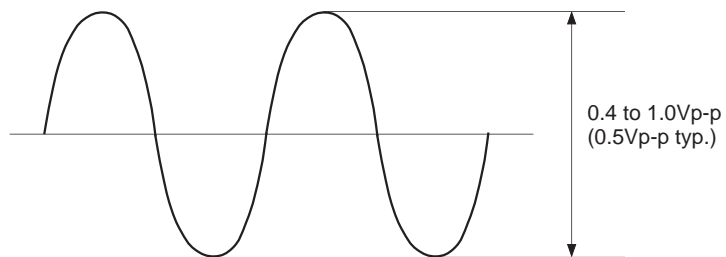

Electrical Characteristics Test Circuit

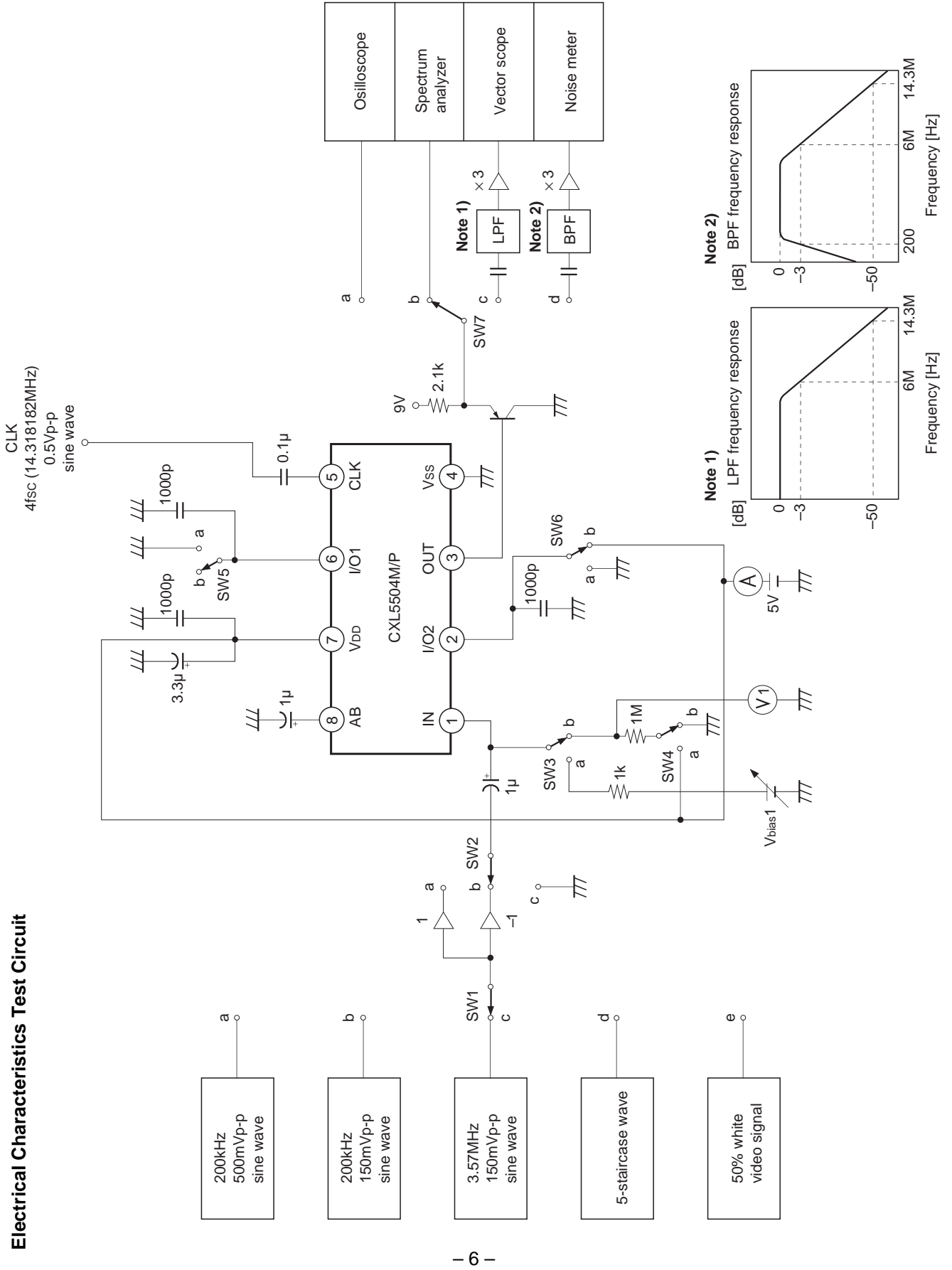

Application Circuit (Using PN mode)

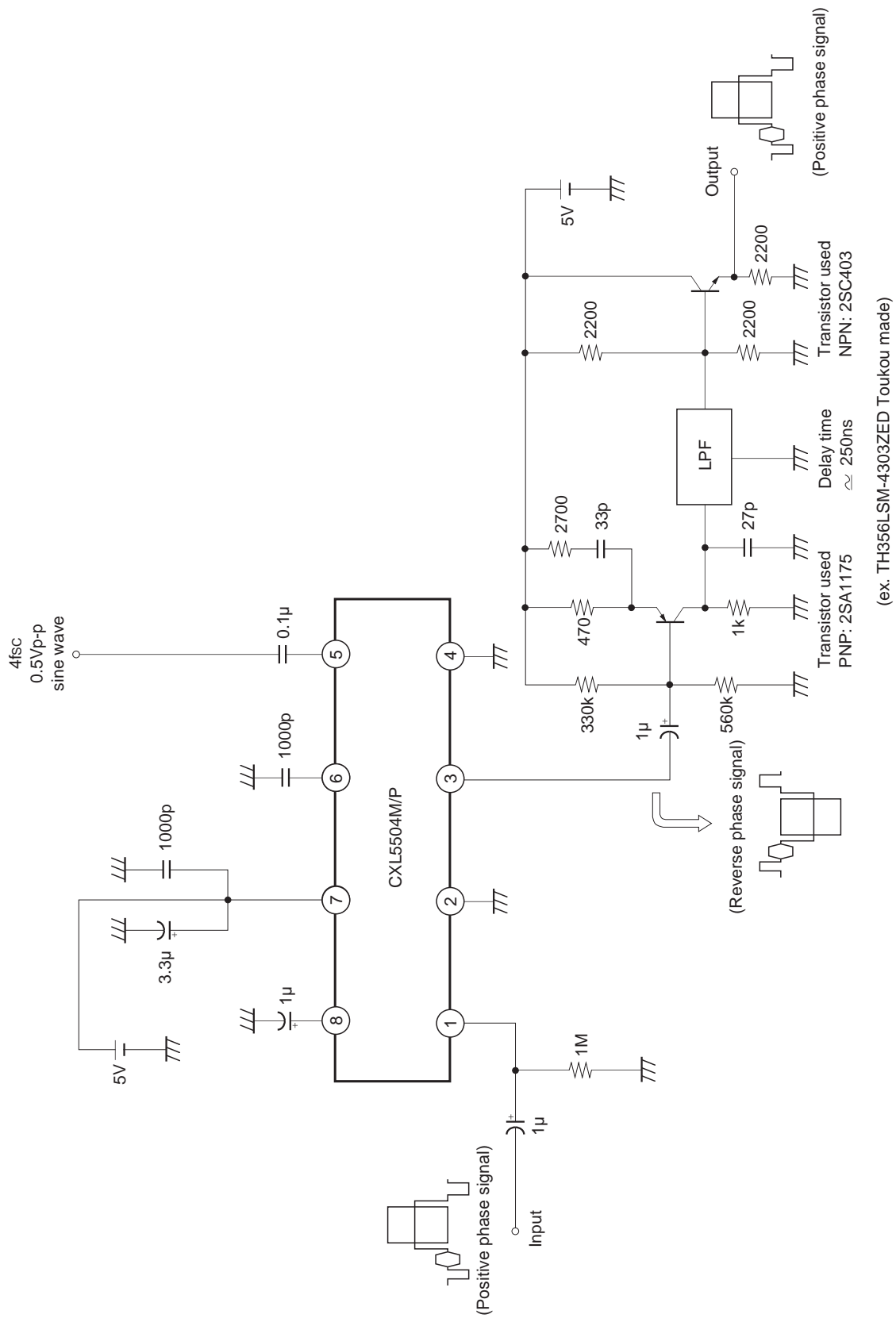

Application circuits shown are typical examples illustrating the operation of the devices. Sony cannot assume responsibility for any problems arising out of the use of these circuits or for any infringement of third party patent and other right due to same.

Example of Representative Characteristics

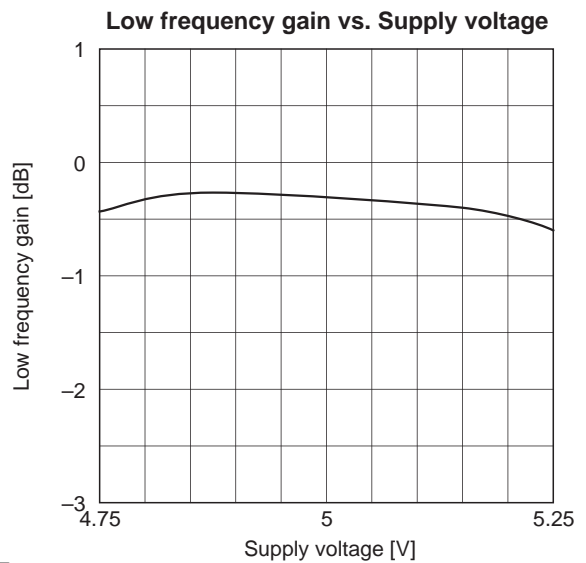
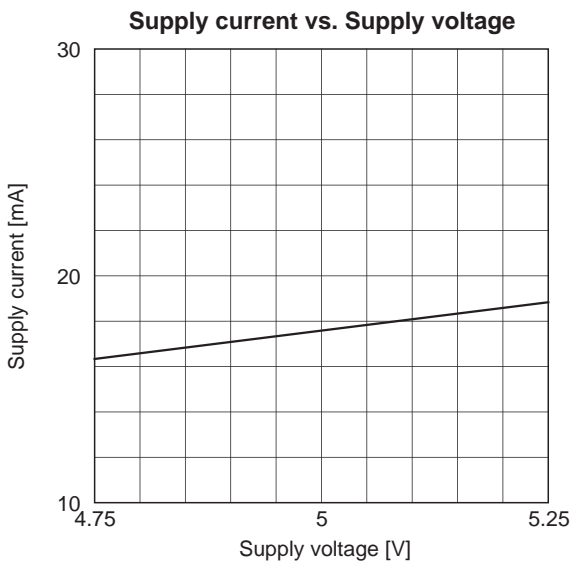
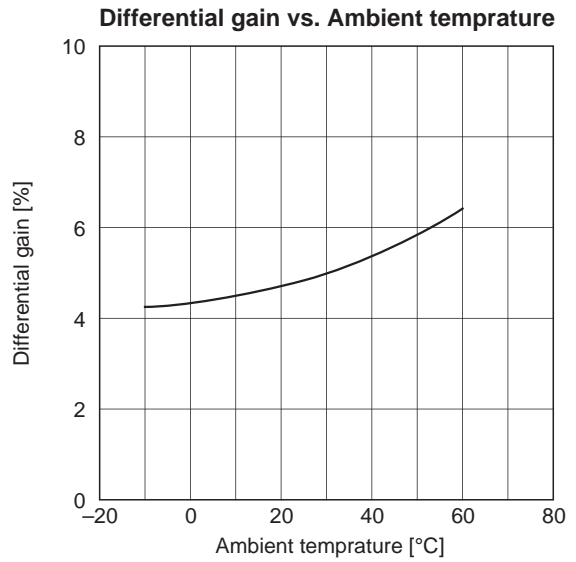
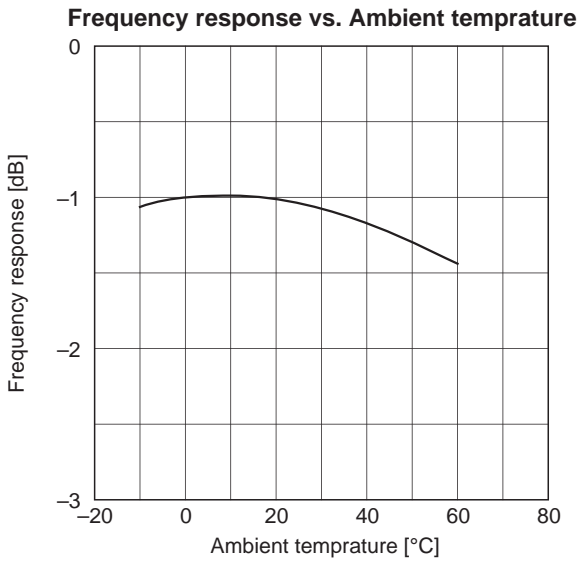
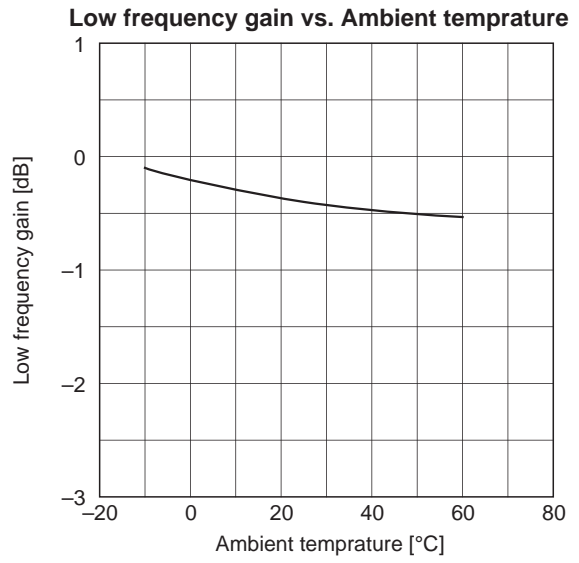
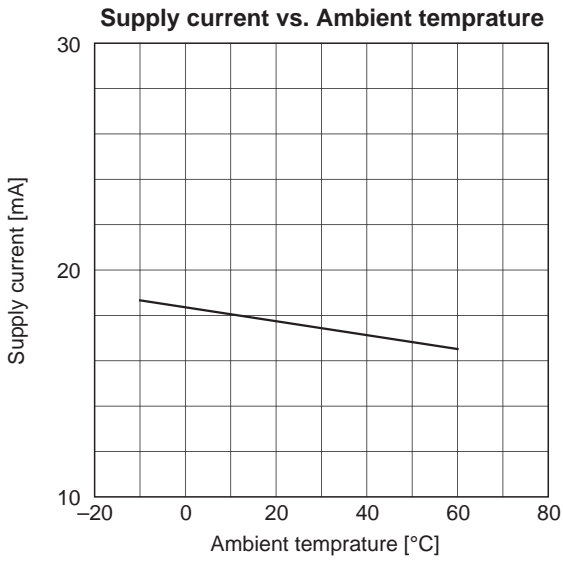

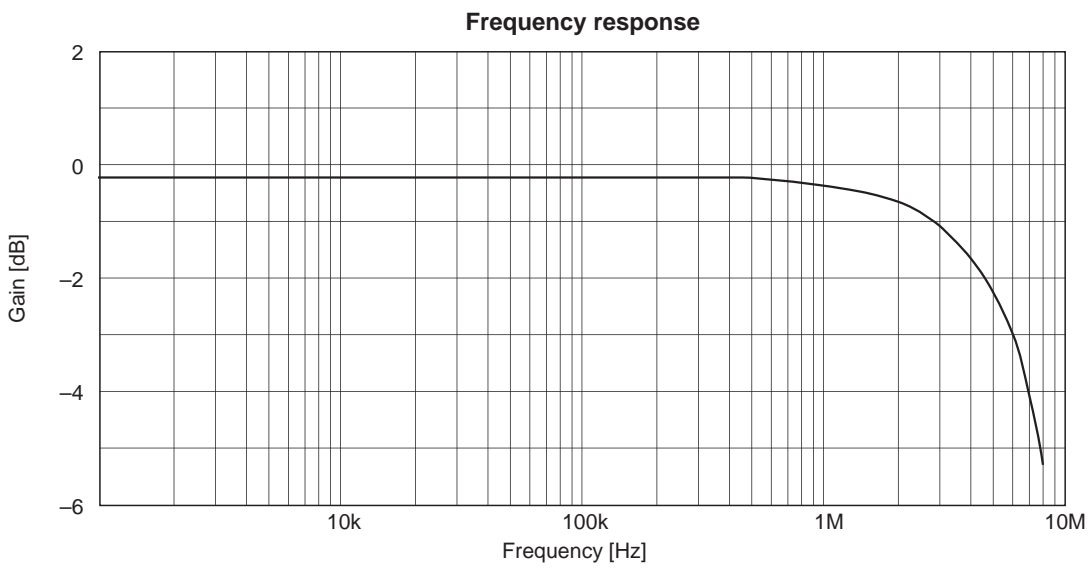
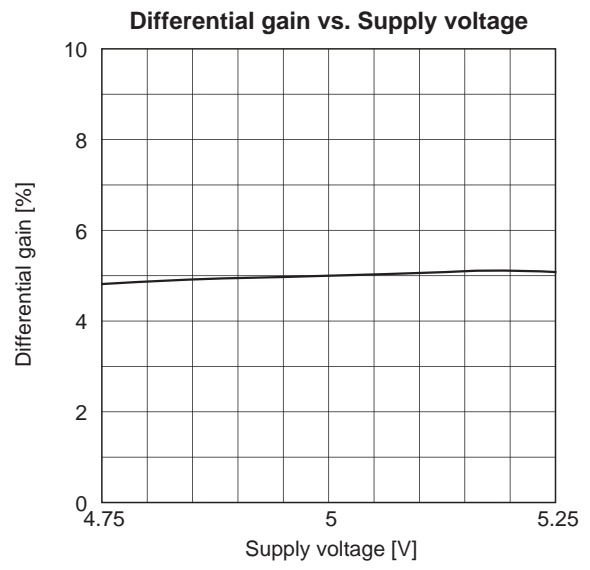
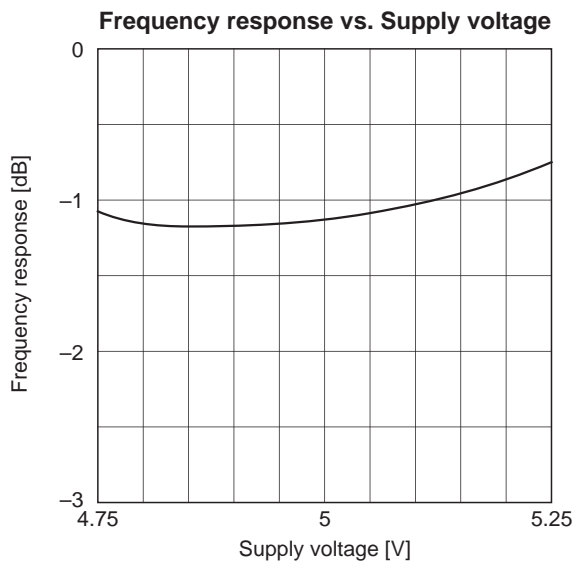

Package Outline

Unit: mm

CXL5504M

8PIN SOP (PLASTIC)

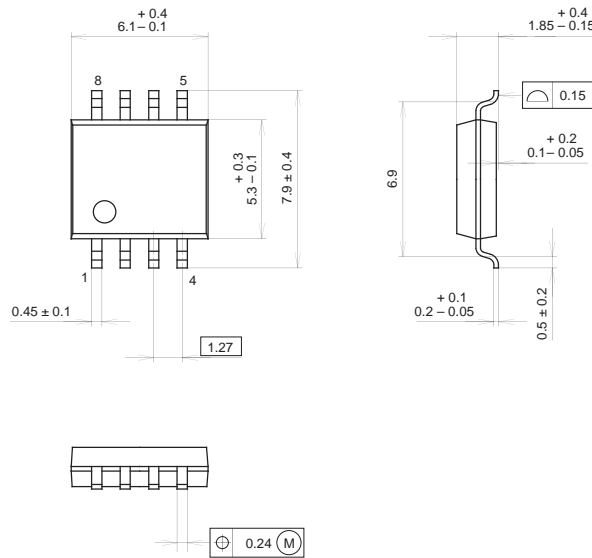

SONY CODE	SOP-8P-L01
EIAJ CODE	SOP008-P-0300
JEDEC CODE	

PACKAGE STRUCTURE

PACKAGE MATERIAL	EPOXY RESIN
LEAD TREATMENT	SOLDER PLATING
LEAD MATERIAL	42/COPPER ALLOY
PACKAGE MASS	0.1g

8PIN SOP (PLASTIC)

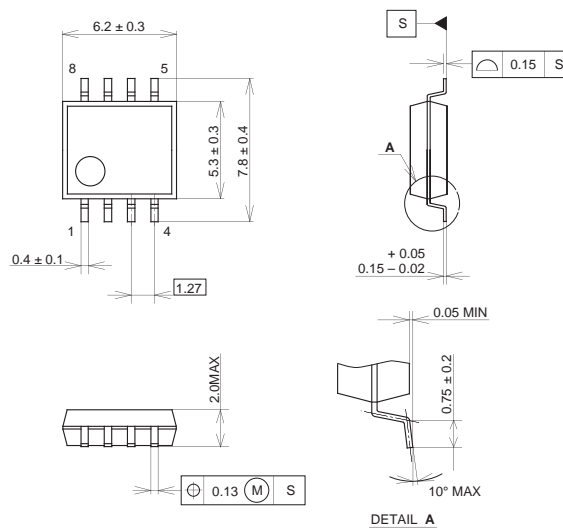

SONY CODE	SOP-8P-L121
EIAJ CODE	SOP008-P-0300
JEDEC CODE	

PACKAGE STRUCTURE

PACKAGE MATERIAL	EPOXY RESIN
LEAD TREATMENT	PALLADIUM PLATING
LEAD MATERIAL	COPPER ALLOY
PACKAGE MASS	0.1g

CXL5504P

8PIN DIP (PLASTIC)

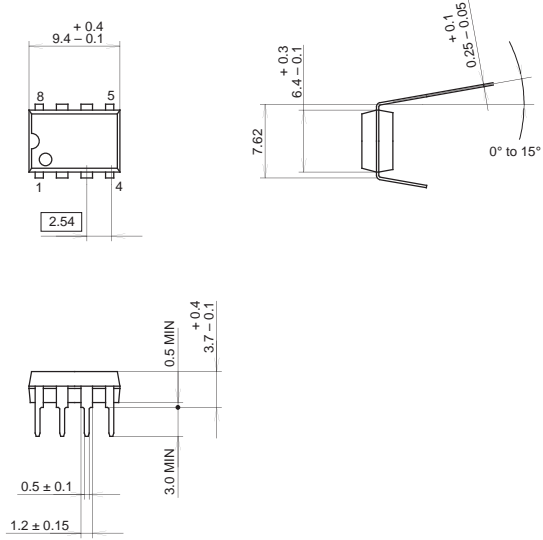

PACKAGE STRUCTURE

SONY CODE	DIP-8P-01
EIAJ CODE	DIP008-P-0300
JEDEC CODE	_____

PACKAGE MATERIAL	EPOXY RESIN
LEAD TREATMENT	SOLDER PLATING
LEAD MATERIAL	COPPER ALLOY
PACKAGE MASS	0.5g

This datasheet has been downloaded from:

[www.DatasheetCatalog.com](http://www.DatasheetCatalog.com)

Datasheets for electronic components.



LittleDiode supplies new, hard to find or obsolete electronic components and semiconductors all over the world.

With over two million different components listed you are sure to find the part you need.

Feel free to visit us today at our online store:

**[LittleDiode.com](http://LittleDiode.com)**

Looking forward to providing you with the best possible service.