



CYPRESS

CY22150

# One-PLL General-Purpose Flash-Programmable and 2-Wire Serially Programmable Clock Generator

## Features

- Integrated phase-locked loop (PLL)
- Commercial and industrial operation
- Flash-programmable
- Field-programmable
- 2-wire serial programming interface
- Low-skew, low-jitter, high-accuracy outputs
- 3.3V operation with 2.5V output option
- 16-lead TSSOP

## Benefits

- Internal PLL to generate six outputs up to 200 MHz. Able to generate custom frequencies from an external crystal or a driven source.
- Performance guaranteed for applications that require an extended temperature range.
- Nonvolatile reprogrammable technology allows easy customization, quick turnaround on design changes and product performance enhancements, and better inventory control. Parts can be reprogrammed up to 100

times, reducing inventory of custom parts and providing an easy method for upgrading existing designs.

- The CY22150 can be programmed at the package level. In-house programming of samples and prototype quantities is available using the CY3672 FTG Development Kit. Production quantities are available through Cypress's value-added distribution partners or by using third party programmers from BP Micro-systems™, HiLo Systems™, and others.
- The CY22150 provides an industry-standard interface for volatile, system-level customization of unique frequencies and options. Serial programming and reprogramming allows quick design changes and product enhancements, eliminates inventory of old design parts, and simplifies manufacturing.
- High performance suited for commercial, industrial, networking, telecomm and other general-purpose applications.
- Application compatibility in standard and low-power systems.
- Industry-standard packaging saves on board space.

## Logic Block Diagram

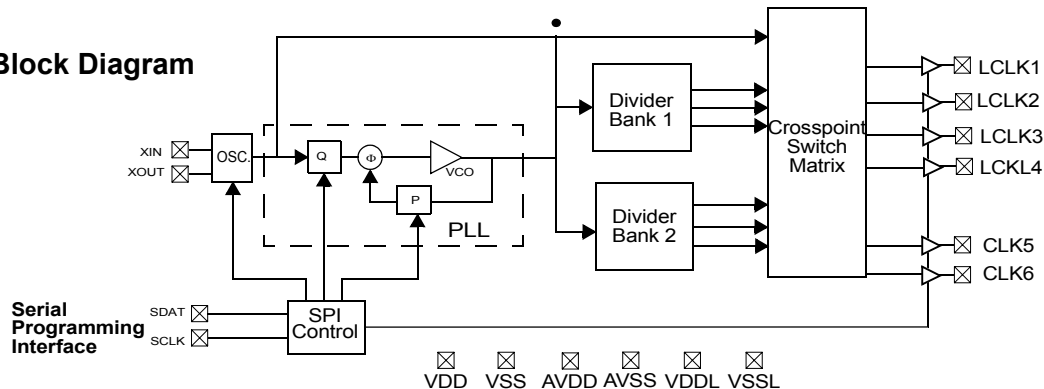

## Pin Configuration

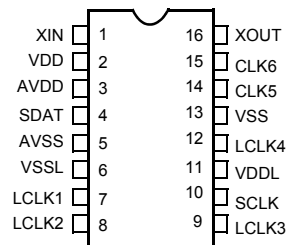

Part Number	Outputs	Input Frequency Range	Output Frequency Range	Specifications
CY22150FC	6	8 MHz–30 MHz (external crystal) 1 MHz–133 MHz (driven clock)	80 kHz–200 MHz (3.3V) 80 KHz–166.6 MHz (2.5V)	Field programmable Serially programmable Commercial temperature
CY22150FI	6	8 MHz–30 MHz (external crystal) 1 MHz–133 MHz (driven clock)	80 kHz – 166.6 MHz (3.3V) 80 KHz – 150 MHz (2.5V)	Field programmable Serially programmable Industrial temperature

### Pin Definitions

Pin Name	Pin Number	Pin Description
XIN	1	<b>Reference Input.</b> Driven by a crystal (8 MHz – 30 MHz) or external clock (1 MHz – 133 MHz). Programmable input load capacitors allow for maximum flexibility in selecting a crystal, regardless of manufacturer, process, performance, or quality.
VDD	2	<b>3.3V voltage supply</b>
AVDD	3	<b>3.3V analog voltage supply</b>
SDAT	4	<b>Serial data input</b>
AVSS	5	<b>Analog ground</b>
VSSL	6	<b>LCLK ground</b>
LCLK1	7	<b>Configurable clock output 1</b> at V <sub>DDL</sub> level (3.3V or 2.5V)
LCLK2	8	<b>Configurable clock output 2</b> at V <sub>DDL</sub> level (3.3V or 2.5V)
LCLK3	9	<b>Configurable clock output 3</b> at V <sub>DDL</sub> level (3.3V or 2.5V)
SCLK	10	<b>Serial clock input</b>
VDDL	11	<b>LCLK voltage supply</b> (2.5V or 3.3V)
LCLK4	12	<b>Configurable clock output 4</b> at V <sub>DDL</sub> level (3.3V or 2.5V)
VSS	13	<b>Ground</b>
CLK5	14	<b>Configurable clock output 5</b> (3.3V)
CLK6	15	<b>Configurable clock output 6</b> (3.3V)
XOUT <sup>[1]</sup>	16	<b>Reference output</b>

### Frequency Calculation and Register Definitions

The CY22150 is an extremely flexible clock generator with four basic variables that can be used to determine the final output frequency. They are the input reference frequency (REF), the internally calculated P and Q dividers, and the post divider, which can be a fixed or calculated value. There are three basic formulas for determining the final output frequency of a CY22150-based design:

- $CLK = ((REF * P)/Q)/Post\ Divider$
- $CLK = REF/Post\ Divider$
- $CLK = REF$ .

**Note:**

1. Float XOUT if XIN is driven by an external clock source.

The basic PLL block diagram is shown in *Figure 1*. Each of the six clock outputs on the CY22150 has a total of seven output options available to it. There are six post divider options available: /2 (two of these), /3, /4, /DIV1N and /DIV2N. DIV1N and DIV2N are independently calculated and are applied to individual output groups. The post divider options can be applied to the calculated VCO frequency  $((REF * P)/Q)$  or to the REF directly.

In addition to the six post divider output options, the seventh option bypasses the PLL and passes the REF directly to the crosspoint switch matrix.

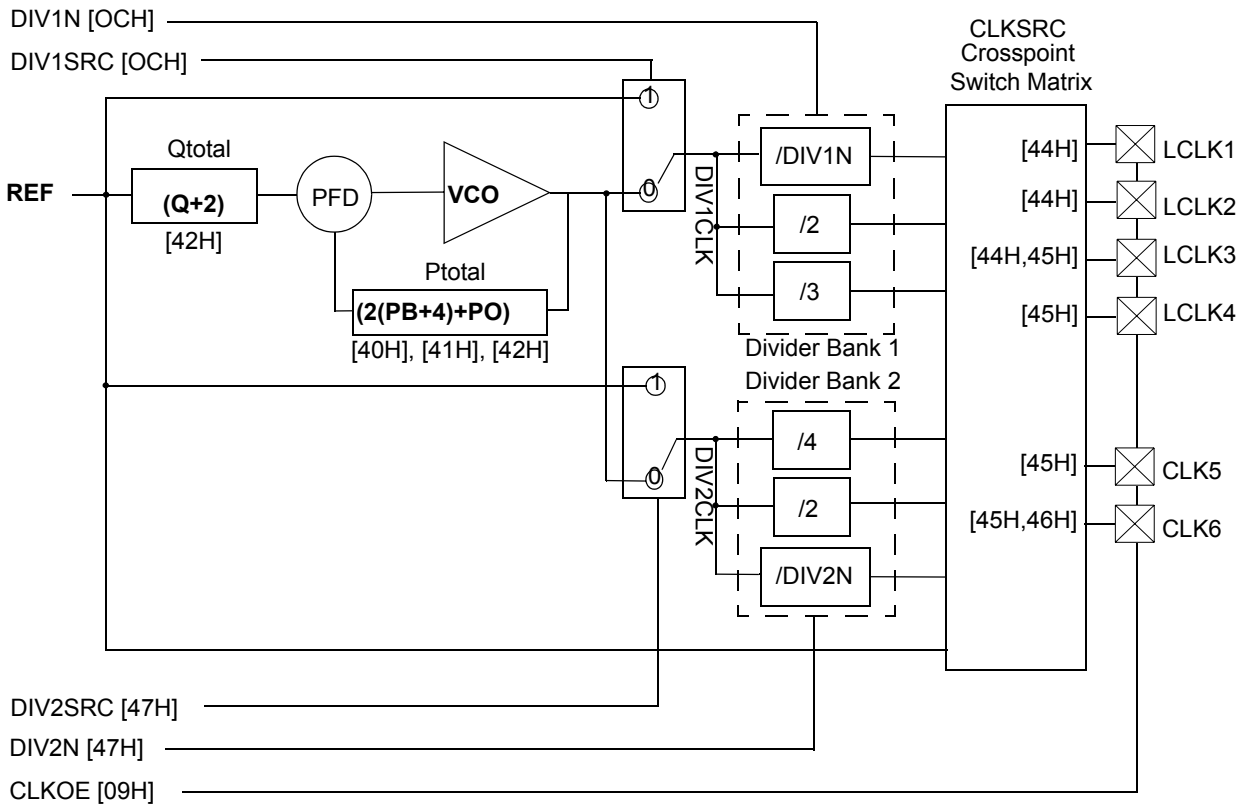

**Figure 1. Basic Block Diagram of CY22150 PLL**

### Default Start-up Condition for the CY22150

The default (programmed) condition of the device is generally set by the distributor who programs the device using a customer-specific JEDEC file produced by CyClocksRT™. Parts shipped from the factory are blank and unprogrammed. In this condition, all bits are set to 0, all outputs are three-stated, and the crystal oscillator circuit is active.

While you can develop your own subroutine to program any or all of the individual registers described in the following pages, it may be easier to use CyClocksRT to produce the required register setting file.

The serial interface address of the CY22150 is 69H. Should there be a conflict with any other devices in your system, this can also be changed using CyClocksRT.

### Frequency Calculations and Register Definitions Using the Serial Programming Interface

The CY22150 provides an industry standard serial interface for volatile, in-system programming of unique frequencies and options. Serial programming and reprogramming allows for quick design changes and product enhancements, eliminates inventory of old design parts, and simplifies manufacturing.

The Serial Programming Interface (SPI) provides volatile programming, i.e., when the target system is powered down, the CY22150 reverts to its pre-SPI state, as defined above (programmed or unprogrammed). When the system is

powered back up again, the SPI registers will need to be reconfigured again.

All programmable registers in the CY22150 are addressed with eight bits and contain eight bits of data. The CY22150 is a slave device with an address of 1101001 (69H).

Table 1 lists the SPI registers and their definitions. Specific register definitions and their allowable values are listed below.

### Reference Frequency

The REF can be a crystal or a driven frequency. For crystals, the frequency range must be between 8 MHz and 30 MHz. For a driven frequency, the frequency range must be between 1 MHz and 133 MHz.

#### Using a Crystal as the Reference Input

The input crystal oscillator of the CY22150 is an important feature because of the flexibility it allows the user in selecting a crystal as a REF source. The input oscillator has programmable gain, allowing for maximum compatibility with a reference crystal, regardless of manufacturer, process, performance and quality.

#### Programmable Crystal Input Oscillator Gain Settings

The Input crystal oscillator gain (XDRV) is controlled by two bits in register 12H, and are set according to Table 2. The parameters controlling the gain are the crystal frequency, the internal crystal parasitic resistance (ESR, available from the

manufacturer), and the CapLoad setting during crystal start-up.

Bits 3 and 4 of register 12H control the input crystal oscillator gain setting. Bit 4 is the MSB of the setting, and bit 3 is the LSB. The setting is programmed according to *Table 2*. All other

bits in the register are reserved and should be programmed as shown in *Table 3*.

*Using an External Clock as the Reference Input*

The CY22150 can also accept an external clock as reference, with speeds up to 133 MHz. With an external clock, the XDRV (register 12H) bits must be set according to *Table 4*.

**Table 1. Summary Table – CY22150 Programmable Registers**

Register	Description	D7	D6	D5	D4	D3	D2	D1	D0
09H	CLKOE control	0	0	CLK6	CLK5	LCLK4	LCLK3	LCLK2	LCLK1
OCH	DIV1SRC mux and DIV1N divider	DIV1SRC	DIV1N(6)	DIV1N(5)	DIV1N(4)	DIV1N(3)	DIV1N(2)	DIV1N(1)	DIV1N(0)
12H	Input crystal oscillator drive control	0	0	1	XDRV(1)	XDRV(0)	0	0	0
13H	Input load capacitor control	CapLoad (7)	CapLoad (6)	CapLoad (5)	CapLoad (4)	CapLoad (3)	CapLoad (2)	CapLoad (1)	CapLoad (0)
40H	Charge Pump and PB counter	1	1	0	Pump(2)	Pump(1)	Pump(0)	PB(9)	PB(8)
41H		PB(7)	PB(6)	PB(5)	PB(4)	PB(3)	PB(2)	PB(1)	PB(0)
42H	PO counter, Q counter	PO	Q(6)	Q(5)	Q(4)	Q(3)	Q(2)	Q(1)	Q(0)
44H	Crosspoint switch matrix control	CLKSRC2 for LCLK1	CLKSRC1 for LCLK1	CLKSRC0 for LCLK1	CLKSRC2 for LCLK2	CLKSRC1 for LCLK2	CLKSRC0 for LCLK2	CLKSRC2 for LCLK3	CLKSRC1 for LCLK3
45H		CLKSRC0 for LCLK3	CLKSRC2 for LCLK4	CLKSRC1 for LCLK4	CLKSRC0 for LCLK4	CLKSRC2 for CLK5	CLKSRC1 for CLK5	CLKSRC0 for CLK5	CLKSRC2 for CLK6
46H		CLKSRC1 for CLK6	CLKSRC0 for CLK6	1	1	1	1	1	1
47H	DIV2SRC mux and DIV2N divider	DIV2SRC	DIV2N(6)	DIV2N(5)	DIV2N(4)	DIV2N(3)	DIV2N(2)	DIV2N(1)	DIV2N(0)

**Table 2. Programmable Crystal Input Oscillator Gain Settings**

	Cap Register Settings	00H – 80H		80H – C0H		C0H – FFH	
	Effective Load Capacitance (CapLoad)	6 pF to 12 pF		12pF to 18pF		18pF to 30pF	
	Crystal ESR	30Ω	60Ω	30Ω	60Ω	30Ω	60Ω
Crystal Input Frequency	8 – 15 MHz	00	01	01	10	01	10
	15 – 20 MHz	01	10	01	10	10	10
	20 – 25 MHz	01	10	10	10	10	11
	25 – 30 MHz	10	10	10	11	11	N/A

**Table 3. Bit Locations and Values**

Address	D7	D6	D5	D4	D3	D2	D1	D0
12H	0	0	1	XDRV(1)	XDRV(0)	0	0	0

**Table 4. Programmable External Reference Input Oscillator Drive Settings**

Reference Frequency	1 – 25 MHz	25 – 50 MHz	50 – 90 MHz	90 – 133 MHz
Drive Setting	00	01	10	11

### Input Load Capacitors

Input load capacitors allow the user to set the load capacitance of the CY22150 to match the input load capacitance from a crystal. The value of the input load capacitors is determined by 8 bits in a programmable register [13H]. Total load capacitance is determined by the formula:

$$\text{CapLoad} = (C_L - C_{\text{BRD}} - C_{\text{CHIP}}) / 0.09375 \text{ pF}$$

where:

- $C_L$  = specified load capacitance of your crystal.
- $C_{\text{BRD}}$  = the total board capacitance, due to external capacitors and board trace capacitance. In CyClocksRT, this value defaults to 2 pF.
- $C_{\text{CHIP}}$  = 6 pF.
- 0.09375 pF = the step resolution available due to the 8-bit register.

In CyClocksRT, only the crystal capacitance ( $C_L$ ) is specified.  $C_{\text{CHIP}}$  is set to 6 pF, and  $C_{\text{BRD}}$  defaults to 2 pF. If your board capacitance is higher or lower than 2 pF, the formula above can be used to calculate a new CapLoad value and programmed into register 13H.

In CyClocksRT, enter the crystal capacitance ( $C_L$ ). The value of CapLoad will be determined automatically and programmed into the CY22150. Through the SDAT and SCLK pins, the value can be adjusted up or down if your board capacitance is greater or less than 2 pF. For an external clock source, CapLoad defaults to 0. See *Table 5* for CapLoad bit locations and values.

The input load capacitors are placed on the CY22150 die to reduce external component cost. These capacitors are true parallel-plate capacitors, designed to reduce the frequency shift that occurs when non-linear load capacitance is affected by load, bias, supply and temperature changes.

### PLL Frequency, Q Counter [42H(6..0)]

The first counter is known as the Q counter. The Q counter divides REF by its calculated value. Q is a 7 bit divider with a maximum value of 127 and minimum value of 0. The primary value of Q is determined by 7 bits in register 42H (6..0), but 2 is added to this register value to achieve the total Q, or  $Q_{\text{total}}$ .  $Q_{\text{total}}$  is defined by the formula:

$$Q_{\text{total}} = Q + 2$$

The minimum value of  $Q_{\text{total}}$  is 2. The maximum value of  $Q_{\text{total}}$  is 129. Register 42H is defined in the table.

Stable operation of the CY22150 cannot be guaranteed if  $\text{REF}/Q_{\text{total}}$  falls below 250 kHz.  $Q_{\text{total}}$  bit locations and values are defined in *Table 6*.

### PLL Frequency, P Counter [40H(1..0)], [41H(7..0)], [42H(7)]

The next counter definition is the P (product) counter. The P counter is multiplied with the ( $\text{REF}/Q_{\text{total}}$ ) value to achieve the

VCO frequency. The product counter, defined as  $P_{\text{total}}$ , is made up of two internal variables, PB and PO. The formula for calculating  $P_{\text{total}}$  is:

$$P_{\text{total}} = (2(\text{PB} + 4) + \text{PO}).$$

PB is a 10-bit variable, defined by registers 40H(1:0) and 41H(7:0). The 2 LSBs of register 40H are the two MSBs of variable PB. Bits 4..2 of register 40H are used to determine the charge pump settings (see Section 5). The 3 MSBs of register 40H are preset and reserved and cannot be changed. PO is a single bit variable, defined in register 42H(7). This allows for odd numbers in  $P_{\text{total}}$ .

The remaining seven bits of 42H are used to define the Q counter, as shown in *Table 6*.

The minimum value of  $P_{\text{total}}$  is 8. The maximum value of  $P_{\text{total}}$  is 2055. To achieve the minimum value of  $P_{\text{total}}$ , PB and PO should both be programmed to 0. To achieve the maximum value of  $P_{\text{total}}$ , PB should be programmed to 1023, and PO should be programmed to 1.

Stable operation of the CY22150 cannot be guaranteed if the value of ( $P_{\text{total}} * (\text{REF}/Q_{\text{total}})$ ) is above 400 MHz or below 100 MHz. Registers 40H, 41H and 42H are defined in *Table 7*. PLL Post Divider Options [OCH(7..0)], [47H(7..0)]

The output of the VCO is routed through two independent muxes, then to two divider banks to determine the final clock output frequency. The mux determines if the clock signal feeding into the divider banks is the calculated VCO frequency or REF. There are two select muxes (DIV1SRC and DIV2SRC) and two divider banks (Divider Bank 1 and Divider Bank 2) used to determine this clock signal. The clock signal passing through DIV1SRC and DIV2SRC is referred to as DIV1CLK and DIV2CLK, respectively.

The divider banks have 4 unique divider options available: /2, /3, /4, and /DIVxN. DIVxN is a variable that can be independently programmed (DIV1N and DIV2N) for each of the two divider banks. The minimum value of DIVxN is 4. The maximum value of DIVxN is 127. A value of DIVxN below 4 is not guaranteed to work properly.

DIV1SRC is a single bit variable, controlled by register OCH. The remaining seven bits of register OCH determine the value of post divider DIV1N.

DIV2SRC is a single bit variable, controlled by register 47H. The remaining seven bits of register 47H determine the value of post divider DIV2N.

Register OCH and 47H are defined in *Table 8*.

### Charge Pump Settings [40H(2..0)]

The correct pump setting is important for PLL stability. Charge pump settings are controlled by bits (4..2) of register 40H, and are dependent on internal variable PB (see "PLL Frequency, P Counter[40H(1..0)], [41H(7..0)], [42H(7)]"). *Table 9* summarizes the proper charge pump settings, based on  $P_{\text{total}}$ .

See *Table 10* for register 40H bit locations and values.

**Table 5. Input Load Capacitor Register Bit Settings**

Address	D7	D6	D5	D4	D3	D2	D1	D0
13H	CapLoad(7)	CapLoad(6)	CapLoad(5)	CapLoad(4)	CapLoad(3)	CapLoad(2)	CapLoad(1)	CapLoad(0)

**Table 6. P Counter Register Definition**

Address	D7	D6	D5	D4	D3	D2	D1	D0
40H	1	1	0	Pump(2)	Pump(1)	Pump(0)	PB(9)	PB(8)
41H	PB(7)	PB(6)	PB(5)	PB(4)	PB(3)	PB(2)	PB(1)	PB(0)
42H	PO	Q(6)	Q(5)	Q(4)	Q(3)	Q(2)	Q(1)	Q(0)

**Table 7. P Counter Register Definition**

Address	D7	D6	D5	D4	D3	D2	D1	D0
40H	1	1	0	Pump(2)	Pump(1)	Pump(0)	PB(9)	PB(8)
41H	PB(7)	PB(6)	PB(5)	PB(4)	PB(3)	PB(2)	PB(1)	PB(0)
42H	PO	Q(6)	Q(5)	Q(4)	Q(3)	Q(2)	Q(1)	Q(0)

**Table 8. PLL Post Divider Options**

Address	D7	D6	D5	D4	D3	D2	D1	D0
OCH	DIV1SRC	DIV1N(6)	DIV1N(5)	DIV1N(4)	DIV1N(3)	DIV1N(2)	DIV1N(1)	DIV1N(0)
47H	DIV2SRC	DIV2N(6)	DIV2N(5)	DIV2N(4)	DIV2N(3)	DIV2N(2)	DIV2N(1)	DIV2N(0)

**Table 9. Charge Pump Settings**

Charge Pump Setting – Pump(2..0)	Calculated P <sub>total</sub>
000	16 – 44
001	45 – 479
010	480 – 639
011	640 – 799
100	800 – 1023
101, 110, 111	Do not use – device will be unstable

**Table 10. Register 40H Change Pump Bit Settings**

Address	D7	D6	D5	D4	D3	D2	D1	D0
40H	1	1	0	Pump(2)	Pump(1)	Pump(0)	PB(9)	PB(8)

Although using the above table will guarantee stability, it is recommended to use the Print Preview function in CyClocksRT to determine the correct charge pump settings for optimal jitter performance.

PLL stability cannot be guaranteed for values below 16 and above 1023. If values above 1023 are needed, use CyClocksRT to determine the best charge pump setting.

**Clock Output Settings: CLKSRC – Clock Output Cross-point Switch Matrix [44H(7..0)], [45H(7..0)], [46H(7..6)]**

**CLKOE – Clock Output Enable Control [09H(5..0)]**

Every clock output can be defined to come from one of seven unique frequency sources. The CLKSRC(2..0) crosspoint switch matrix defines which source is attached to each individual clock output. CLKSRC(2..0) is set in Registers 44H, 45H, and 46H. The remainder of register 46H(5:0) must be written with the values stated in the register table when writing register values 46H(7:6).

In addition, each clock output has individual CLKOE control, set by register 09H(5..0).

When DIV1N is divisible by four, then CLKSRC(0,1,0) is guaranteed to be rising edge phase-aligned with CLKSRC(0,0,1). When DIV1N is six, then CLKSRC(0,1,1) is

guaranteed to be rising edge phase-aligned with CLKSRC(0,0,1).

When DIV2N is divisible by four, then CLKSRC(1,0,1) is guaranteed to be rising edge phase-aligned with CLKSRC(1,0,0). When DIV2N is divisible by eight, then CLKSRC(1,1,0) is guaranteed to be rising edge phase-aligned with CLKSRC(1,0,0).

Each clock output has its own output enable, controlled by register 09H(5..0). To enable an output, set the corresponding CLKOE bit to 1. CLKOE settings are in Table 13.

The output swing of LCLK1 through LCLK4 is set by V<sub>DDL</sub>. The output swing of CLK5 and CLK6 is set by V<sub>DD</sub>.

**Test, Reserved, and Blank Registers**

Writing to any of the following registers will cause the part to exhibit abnormal behavior, as follows.

- [00H to 08H] – Reserved
- [0AH to 0BH] – Reserved
- [0DH to 11H] – Reserved
- [14H to 3FH] – Reserved
- [43H] – Reserved
- [48H to FFH] – Reserved.

**Table 11.**

CLKSRC2	CLKSRC1	CLKSRC0	Definition and Notes
0	0	0	Reference input.
0	0	1	DIV1CLK/DIV1N. DIV1N is defined by register [OCH]. Allowable values for DIV1N are 4 to 127. If Divider Bank 1 is not being used, set DIV1N to 8.
0	1	0	DIV1CLK/2. Fixed /2 divider option. If this option is used, DIV1N must be divisible by 4.
0	1	1	DIV1CLK/3. Fixed /3 divider option. If this option is used, set DIV1N to 6.
1	0	0	DIV2CLK/DIV2N. DIV2N is defined by Register [47H]. Allowable values for DIV2N are 4 to 127. If Divider Bank 2 is not being used, set DIV2N to 8.
1	0	1	DIV2CLK/2. Fixed /2 divider option. If this option is used, DIV2N must be divisible by 4.
1	1	0	DIV2CLK/4. Fixed /4 divider option. If this option is used, DIV2N must be divisible by 8.
1	1	1	Reserved – do not use.

**Table 12.**

Address	D7	D6	D5	D4	D3	D2	D1	D0
44H	CLKSRC2 for LCLK1	CLKSRC1 for LCLK1	CLKSRC0 for LCLK1	CLKSRC2 for LCLK2	CLKSRC1 for LCLK2	CLKSRC0 for LCLK2	CLKSRC2 for LCLK3	CLKSRC1 for LCLK3
45H	CLKSRC0 for LCLK3	CLKSRC2 for LCLK4	CLKSRC1 for LCLK4	CLKSRC0 for LCLK4	CLKSRC2 for CLK5	CLKSRC1 for CLK5	CLKSRC0 for CLK5	CLKSRC2 for CLK6
46H	CLKSRC1 for CLK6	CLKSRC0 for CLK6	1	1	1	1	1	1

**Table 13. CLKOE Bit Setting**

Address	D7	D6	D5	D4	D3	D2	D1	D0
09H	0	0	CLK6	CLK5	LCLK4	LCLK3	LCLK2	LCLK1

### Programmable Interface Timing

The CY22150 utilizes a 2-wire serial-interface SDAT and SCLK that operates up to 400 kbits/second in Read or Write mode. The basic Write serial format is as follows.

Start Bit; seven-bit Device Address (DA); R/W Bit; Slave Clock Acknowledge (ACK); eight-bit Memory Address (MA); ACK; eight-bit data; ACK; eight-bit data in MA + 1 if desired; ACK; eight-bit data in MA+2; ACK; etc. until STOP bit. The basic serial format is illustrated in *Figure 3*.

#### Data Valid

Data is valid when the Clock is HIGH, and may only be transitioned when the clock is LOW, as illustrated in *Figure 2*.

#### Data Frame

Every new data frame is indicated by a start and stop sequence, as illustrated in *Figure 4*.

**Start Sequence** – Start frame is indicated by SDAT going LOW when SCLK is HIGH. Every time a Start signal is given, the next eight-bit data must be the device address (seven bits) and a R/W bit, followed by register address (eight bits) and register data (eight bits).

**Stop Sequence** – Stop frame is indicated by SDAT going HIGH when SCLK is HIGH. A Stop frame frees the bus for writing to another part on the same bus or writing to another random register address.

#### Acknowledge Pulse

During Write mode, the CY22150 will respond with an ACK pulse after every eight bits. This is accomplished by pulling the SDAT line LOW during the N\*9<sup>th</sup> clock cycle, as illustrated in *Figure 5*. (N = the number of eight-bit segments transmitted.) During Read mode, the ACK pulse after the data packet is sent is generated by the master.

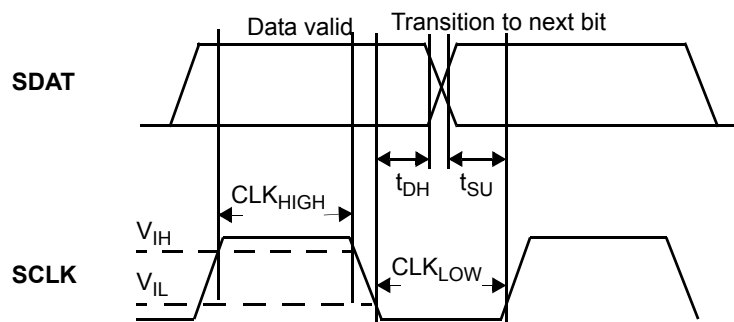
**Figure 2. Data Valid and Data Transition Periods**

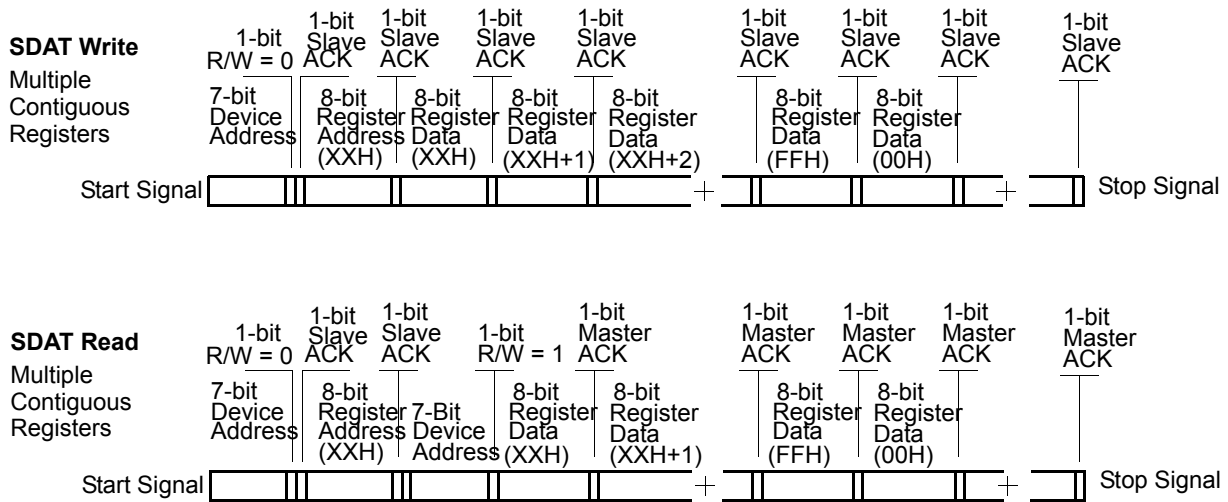
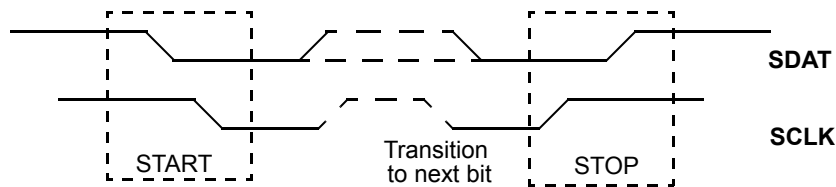
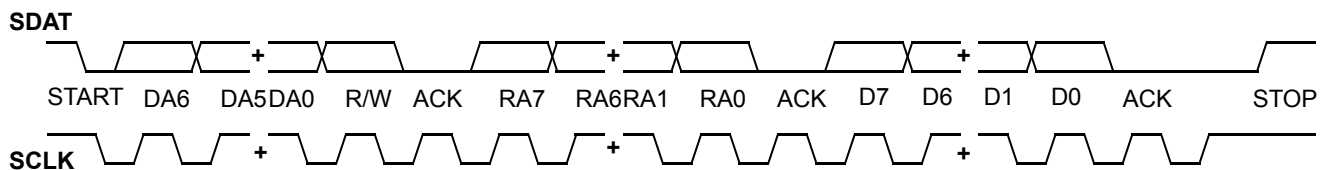
**Figure 3. Data Frame Architecture**

**Figure 4. Start and Stop Frame**

**Figure 5. Frame Format (Device Address, R/W, Register Address, Register Data)**

Parameter	Description	Min.	Max.	Unit
$f_{SCLK}$	Frequency of SCLK		400	kHz
	Start mode time from SDA LOW to SCL LOW	0.6		$\mu$ s
$CLK_{LOW}$	SCLK LOW period	1.3		$\mu$ s
$CLK_{HIGH}$	SCLK HIGH period	0.6		$\mu$ s
$t_{SU}$	Data transition to SCLK HIGH	100		ns
$t_{DH}$	Data hold (SCLK LOW to data transition)	0		ns
	Rise time of SCLK and SDAT		300	ns
	Fall time of SCLK and SDAT		300	ns
	Stop mode time from SCLK HIGH to SDAT HIGH	0.6		$\mu$ s
	Stop mode to Start mode	1.3		$\mu$ s

## Applications

### Controlling Jitter

Jitter is defined in many ways including: phase noise, long-term jitter, cycle to cycle jitter, period jitter, absolute jitter, and deterministic. These jitter terms are usually given in terms of rms, peak to peak, or in the case of phase noise dBc/Hz with respect to the fundamental frequency.

Power Supply Noise and clock output loading are two major system sources of clock jitter. Power Supply noise can be mitigated by proper power supply decoupling (0.1  $\mu$ F ceramic cap 0.25") of the clock and ensuring a low impedance ground to the chip. Reducing capacitive clock output loading to a minimum lowers current spikes on the clock edges and thus reduces jitter.

Reducing the total number of active outputs will also reduce jitter in a linear fashion. However, it is better to use two outputs to drive two loads than one output to drive two loads.

### Test Circuit

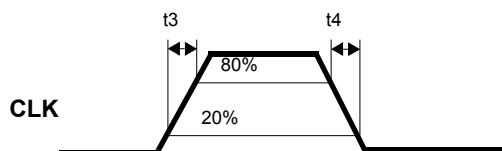
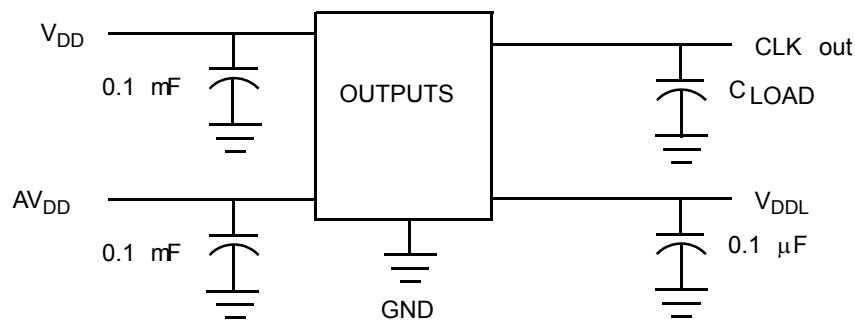

Figure 6. Duty Cycle Definition; DC =  $t_2/t_1$

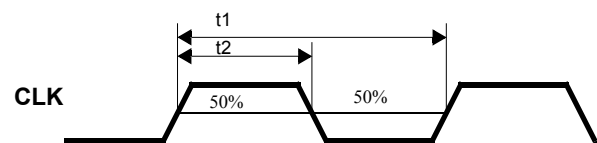

Figure 7. Rise and Fall Time Definitions

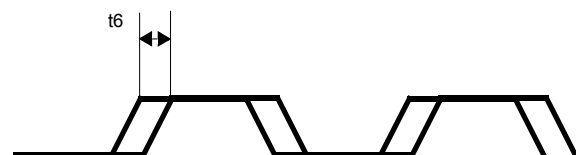

Figure 8. Peak-to-Peak Jitter

The rate and magnitude that the PLL corrects the VCO frequency is directly related to jitter performance. If the rate is too slow, then long term jitter and phase noise will be poor. Therefore, to improve long-term jitter and phase noise, reducing Q to a minimum is advisable. This technique will increase the speed of the Phase Frequency Detector which in turn drive the input voltage of the VCO. In a similar manner increasing P till the VCO is near its maximum rated speed will also decrease long term jitter and phase noise. For example: Input Reference of 12 MHz; desired output frequency of 33.3 MHz. One might arrive at the following solution: Set Q = 3, P = 25, Post Div = 3. However, the best jitter results will be Q = 2, P = 50, Post Div = 9.

For more information, refer to the application note "*Jitter in PLL-Based Systems: Causes, Effects, and Solutions*" available at <http://www.cypress.com/clock/appnotes.html>, or contact your local Cypress field applications engineer.

**Absolute Maximum Conditions**

Parameter	Description	Min.	Max.	Unit
V <sub>DD</sub>	Supply Voltage	-0.5	7.0	V
V <sub>DDL</sub>	I/O Supply Voltage	-0.5	7.0	V
T <sub>S</sub>	Storage Temperature <sup>[2]</sup>	-65	125	°C
T <sub>J</sub>	Junction Temperature		125	°C
	Package Power Dissipation – Commercial Temp		450	mW
	Package Power Dissipation – Industrial Temp		380	mW
	Digital Inputs	AV <sub>SS</sub> - 0.3	AV <sub>DD</sub> + 0.3	V
	Digital Outputs referred to V <sub>DD</sub>	V <sub>SS</sub> - 0.3	V <sub>DD</sub> + 0.3	V
	Digital Outputs referred to V <sub>DDL</sub>	V <sub>SS</sub> - 0.3	V <sub>DDL</sub> + 0.3	V
ESD	Static Discharge Voltage per MIL-STD-883C, Method 3015		2000	V

**Recommended Operating Conditions**

Parameter	Description	Min.	Typ.	Max.	Unit
V <sub>DD</sub>	Operating Voltage	3.135	3.3	3.465	V
V <sub>DDLHI</sub> <sup>[3]</sup>	Operating Voltage	3.135	3.3	3.465	V
V <sub>DDLLO</sub> <sup>[3]</sup>	Operating Voltage	2.375	2.5	2.625	V
T <sub>AC</sub>	Ambient Commercial Temp	0		70	°C
T <sub>AI</sub>	Ambient Industrial Temp	-40		85	°C
C <sub>LOAD</sub>	Max. Load Capacitance, V <sub>DD</sub> /V <sub>DDL</sub> = 3.3V			15	pF
C <sub>LOAD</sub>	Max. Load Capacitance, V <sub>DDL</sub> = 2.5V			15	pF
f <sub>REFD</sub>	Driven REF	1		133	MHz
f <sub>REFC</sub>	Crystal REF	8		30	MHz
t <sub>PU</sub>	Power-up time for all VDDs to reach minimum specified voltage (power ramps must be monotonic)	0.05		500	ms

**DC Electrical Characteristics**

Parameter <sup>[4]</sup>	Name	Description	Min.	Typ.	Max.	Unit
I <sub>OH3.3</sub>	Output High Current	V <sub>OH</sub> = V <sub>DD</sub> - 0.5, V <sub>DD</sub> /V <sub>DDL</sub> = 3.3V (sink)	12	24		mA
I <sub>OL3.3</sub>	Output Low Current	V <sub>OL</sub> = 0.5, V <sub>DD</sub> /V <sub>DDL</sub> = 3.3V (source)	12	24		mA
I <sub>OH2.5</sub>	Output High Current	V <sub>OH</sub> = V <sub>DDL</sub> - 0.5, V <sub>DDL</sub> = 2.5V (source)	8	16		mA
I <sub>OL2.5</sub>	Output Low Current	V <sub>OL</sub> = 0.5, V <sub>DDL</sub> = 2.5V (sink)	8	16		mA
V <sub>IH</sub>	Input High Voltage	CMOS levels, 70% of V <sub>DD</sub>	0.7			V <sub>DD</sub>
V <sub>IL</sub>	Input Low Voltage	CMOS levels, 30% of V <sub>DD</sub>			0.3	V <sub>DD</sub>
C <sub>IN</sub>	Input Capacitance	SCLK and SDAT Pins			7	pF
I <sub>IZ</sub>	Input Leakage Current	SCLK and SDAT Pins		5		μA
V <sub>HYS</sub>	Hysteresis of Schmitt triggered inputs	SCLK and SDAT Pins	0.05			V <sub>DD</sub>
I <sub>VDD</sub> <sup>[5,6]</sup>	Supply Current	AV <sub>DD</sub> /V <sub>DD</sub> Current		45		mA
I <sub>VDDL3.3</sub> <sup>[5,6]</sup>	Supply Current	V <sub>DDL</sub> Current (V <sub>DDL</sub> = 3.465V)		25		mA
I <sub>VDDL2.5</sub> <sup>[5,6]</sup>	Supply Current	V <sub>DDL</sub> Current (V <sub>DDL</sub> = 2.625V)		17		mA

**Notes:**

- Rated for 10 years.
- V<sub>DDL</sub> is only specified and characterized at 3.3V ± 5% and 2.5V ± 5%. V<sub>DDL</sub> may be powered at any value between 3.465V and 2.375V.
- Not 100% tested.
- I<sub>VDD</sub> currents specified for two CLK outputs running at 125 MHz, two LCLK outputs running at 80 MHz, and two LCLK outputs running at 66.6 MHz.
- Use CyClocksRT to calculate actual I<sub>VDD</sub> and I<sub>VDDL</sub> for specific output frequency configurations.

**AC Electrical Characteristics**

Parameter <sup>[7]</sup>	Name	Description	Min.	Typ.	Max.	Unit
t1	Output Frequency, Commercial Temp	Clock output limit, 3.3V	0.08 (80 kHz)		200	MHz
		Clock output limit, 2.5V	0.08 (80 kHz)		166.6	MHz
	Output Frequency, Industrial Temp	Clock output limit, 3.3V	0.08 (80 kHz)		166.6	MHz
		Clock output limit, 2.5V	0.08 (80 kHz)		150	MHz
t2 <sub>LO</sub>	Output Duty Cycle	Duty cycle is defined in <i>Figure 6</i> ; t1/t2 f <sub>OUT</sub> < 166 MHz, 50% of V <sub>DD</sub>	45	50	55	%
t2 <sub>HI</sub>	Output Duty Cycle	Duty cycle is defined in <i>Figure 6</i> ; t1/t2 f <sub>OUT</sub> > 166 MHz, 50% of V <sub>DD</sub>	40	50	60	%
t3 <sub>LO</sub>	Rising Edge Slew Rate (V <sub>DDL</sub> = 2.5V)	Output clock rise time, 20% – 80% of V <sub>DDL</sub> . Defined in <i>Figure 7</i> .	0.6	1.2		V/ns
t4 <sub>LO</sub>	Falling Edge Slew Rate (V <sub>DDL</sub> = 2.5V)	Output clock fall time, 80% – 20% of V <sub>DDL</sub> . Defined in <i>Figure 7</i> .	0.6	1.2		V/ns
t3 <sub>HI</sub>	Rising Edge Slew Rate (V <sub>DDL</sub> = 3.3V)	Output clock rise time, 20% – 80% of V <sub>DD</sub> /V <sub>DDL</sub> . Defined in <i>Figure 7</i> .	0.8	1.4		V/ns
t4 <sub>HI</sub>	Falling Edge Slew Rate (V <sub>DDL</sub> = 3.3V)	Output clock fall time, 80% – 20% of V <sub>DD</sub> /V <sub>DDL</sub> . Defined in <i>Figure 7</i> .	0.8	1.4		V/ns
t5 <sup>[8]</sup>	Skew	Output-output skew between related outputs.			250	ps
t6 <sup>[9]</sup>	Clock Jitter	Peak-to-peak period jitter		250		ps
t10	PLL Lock Time			0.30	3	ms

**Device Characteristics**

Parameter	Name	Value	Unit
θ <sub>JA</sub>	theta JA	115	°C/W
Complexity	Transistor Count	74,600	transistors

**Ordering Information**

Ordering Code	Package Type	Operating Range	Operating Voltage
CY22150FC	16-lead TSSOP	Commercial (0 to 70°C)	3.3V
CY22150FCT	16-lead TSSOP - Tape and Reel	Commercial (0 to 70°C)	3.3V
CY22150FI	16-lead TSSOP	Industrial (-40 to 85°C)	3.3V
CY22150ZC-xxx <sup>[10]</sup>	16-lead TSSOP	Commercial (0 to 70°C)	3.3V
CY22150ZC-xxxT <sup>[10]</sup>	16-lead TSSOP - Tape and Reel	Commercial (0 to 70°C)	3.3V
CY22150ZI-xxx <sup>[10]</sup>	16-lead TSSOP	Industrial (-40 to 85°C)	3.3V
CY22150ZI-xxxT <sup>[10]</sup>	16-lead TSSOP- Tape and Reel	Industrial (-40 to 85°C)	3.3V
CY3672	FTG Development System		
CY3672ADP000	CY22150F Socket		
<b>Lead Free</b>			
CY22150FZXC	16-lead TSSOP	Commercial (0 to 70°C)	3.3V
CY22150FZXCCT	16-lead TSSOP - Tape and Reel	Commercial (0 to 70°C)	3.3V
CY22150FZXI	16-lead TSSOP	Industrial (-40 to 85°C)	3.3V
CY22150FZXIT	16-lead TSSOP - Tape and Reel	Industrial (-40 to 85°C)	3.3V
CY22150ZXC-xxx <sup>[10]</sup>	16-lead TSSOP	Commercial (0 to 70°C)	3.3V
CY22150ZXC-xxxT <sup>[10]</sup>	16-lead TSSOP- Tape and Reel	Commercial (0 to 70°C)	3.3V
CY22150ZXI-xxx <sup>[10]</sup>	16-lead TSSOP	Industrial (-40 to 85°C)	3.3V
CY22150ZXI-xxxT <sup>[10]</sup>	16-lead TSSOP- Tape and Reel	Industrial (-40 to 85°C)	3.3V

**Notes:**

- Not 100% tested, guaranteed by design.
- Skew value guaranteed when outputs are generated from the same divider bank. See Logic Diagram for more information.
- Jitter measurement will vary. Actual jitter is dependent on XIN jitter and edge rate, number of active outputs, output frequencies, V<sub>DDL</sub> (2.5V or 3.3V jitter in "PLL-Based Systems: Causes, Effects, and Solutions," available at <http://www.cypress.com/clock/appnotes.html>, or contact your local Cypress field applications engineer).
- The CY22150ZC-xxx and CY22150ZI-xxx are factory programmed configurations. Factory programming is available for high-volume design opportunities of 100K/year or more in production. For more details, contact your local Cypress FAE or Cypress Sales Representative.

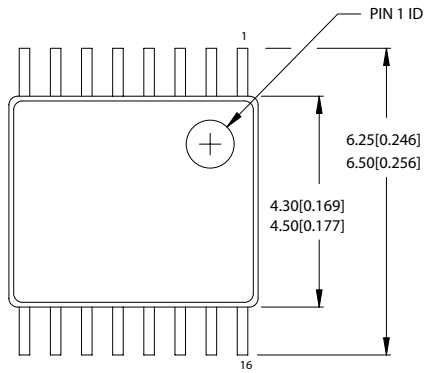
**Package Diagram**
**16-lead TSSOP 4.40 MM Body Z16.173**

 DIMENSIONS IN MM[INCHES] MIN.  
MAX.

REFERENCE JEDEC MO-153

PACKAGE WEIGHT 0.05 gms

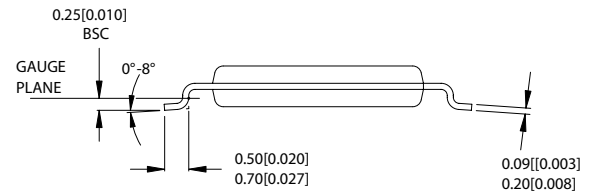
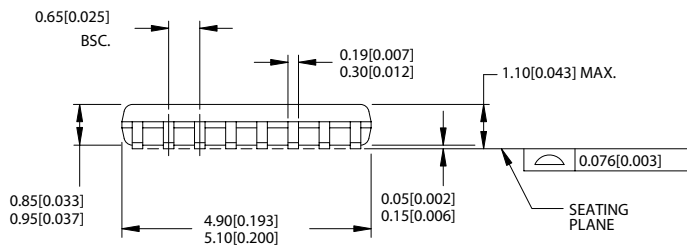
PART #	
Z16.173	STANDARD PKG.
ZZ16.173	LEAD FREE PKG.



51-85091-\*A

BP Microsystems is a trademark of BP Microsystems. HiLo Systems is a trademark of Hi-Lo Systems, Inc. CyClocks is a trademark of Cypress Semiconductor. All product and company names mentioned in this document are the trademarks of their respective holders.

**Document History Page**

Document Title: CY22150 One-PLL General-Purpose Flash-Programmable and 2-Wire Serially-Programmable Clock Generator				
Document Number: 38-07104				
REV.	ECN NO.	Issue Date	Orig. of Change	Description of Change
**	107498	08/08/01	CKN	New Data Sheet
*A	110043	02/06/02	CKN	Preliminary to Final
*B	113514	05/01/02	CKN	Removed overline on <i>Figure 5</i> Register Address Register Data Changed CLK <sub>HIGH</sub> unit from ns to $\mu$ s in parameter description table Added (sink) to rows 1 and 4 and added (source) to rows 2 and 3 in the DC Electrical Characteristics table ( <i>Figure</i> )
*C	121868	12/14/02	RBI	Power-up requirements added to Operating Conditions Information
*D	125453	05/19/03	CKN	Changed 0 to 1 under 12H/D5 of <i>Table 1</i> and <i>Table 3</i> . Reworded and reformatted Programmable Crystal Input Oscillator Gain Settings text.
*E	242808	See ECN	RGL	Minor Change: Fixed the broken line in the block diagram
*F	252352	See ECN	RGL	Corrected Table 2 specs.
*G	296084	See ECN	RGL	Added Lead Free Devices



LittleDiode supplies new, hard to find or obsolete electronic components and semiconductors all over the world.

With over two million different components listed you are sure to find the part you need.

Feel free to visit us today at our online store:

[LittleDiode.com](http://LittleDiode.com)

Looking forward to providing you with the best possible service.