



3.3V SDRAM Buffer for Mobile PCs with 4 SO-DIMMs

Features

- One input to 10 output buffer/driver
- Supports up to four SDRAM SO-DIMMs
- Two additional outputs for feedback
- Serial interface for output control
- Low skew outputs
- Up to 100-MHz operation
- Multiple V_{DD} and V_{SS} pins for noise reduction
- Dedicated OE pin for testing
- Space-saving 28-pin SSOP package
- 3.3V operation

Functional Description

The CY2310ANZ is a 3.3V buffer designed to distribute high-speed clocks in mobile PC applications. The part has 10 outputs, 8 of which can be used to drive up to four SDRAM SO-DIMMs, and the remaining can be used for external feedback to a PLL. The device operates at 3.3V and outputs can run up to 100 MHz, thus making it compatible with Pentium II® processors. The CY2310ANZ can be used in conjunction with the CY2281 or similar clock synthesizer for a full Pentium II motherboard solution.

The CY2310ANZ also includes a serial interface which can enable or disable each output clock. On power-up, all output clocks are enabled. A separate Output Enable pin facilitates testing on ATE.

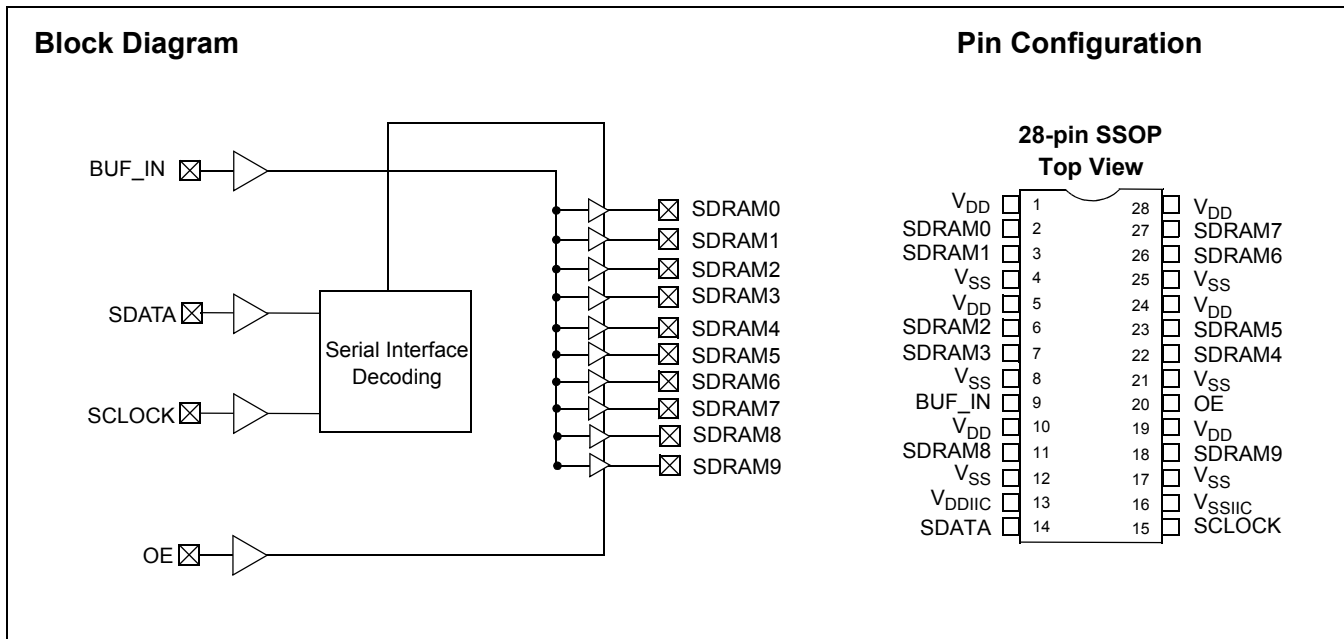

Pin Summary

Name	Pins	Description
V _{DD}	1, 5, 10, 19, 24, 28	3.3V Digital voltage supply
V _{SS}	4, 8, 12, 17, 21, 25	Ground
V _{DDIIC}	13	Serial interface voltage supply
V _{SSIIC}	16	Ground for serial interface
BUF_IN	9	Input clock
OE	20	Output Enable, three-states outputs when LOW. Internal pull-up to V _{DD}
SDATA	14	Serial data input, internal pull-up to V _{DD}
SCLK	15	Serial clock input, internal pull-up to V _{DD}
SDRAM [0–3]	2, 3, 6, 7	SDRAM byte 0 clock outputs
SDRAM [4–7]	22, 23, 26, 27	SDRAM byte 1 clock outputs
SDRAM [8–9]	11, 18	SDRAM byte 2 clock outputs

Device Functionality

OE	SDRAM [0–17]
0	High-Z
1	1 x BUF_IN

Serial Configuration Map

- The Serial bits will be read by the clock driver in the following order:

Byte 0 - Bits 7, 6, 5, 4, 3, 2, 1, 0

Byte 1 - Bits 7, 6, 5, 4, 3, 2, 1, 0

Byte N - Bits 7, 6, 5, 4, 3, 2, 1, 0

- Reserved and unused bits should be programmed to “0”.
- Serial interface address for the CY2310ANZ is:

A6	A5	A4	A3	A2	A1	A0	R/W
1	1	0	1	0	0	1	---

Byte 0: SDRAM Active/Inactive Register (1 = Enable, 0 = Disable), Default = Enabled

Bit	Pin #	Description
Bit 7	--	Initialize to 0
Bit 6	--	Initialize to 0
Bit 5	--	Initialize to 0
Bit 4	--	Initialize to 0
Bit 3	7	SDRAM3 (Active/Inactive)
Bit 2	6	SDRAM2 (Active/Inactive)
Bit 1	3	SDRAM1 (Active/Inactive)
Bit 0	2	SDRAM0 (Active/Inactive)

Byte 1: SDRAM Active/Inactive Register (1 = Active, 0 = Inactive), Default = Active

Bit	Pin #	Description
Bit 7	27	SDRAM7 (Active/Inactive)
Bit 6	26	SDRAM6 (Active/Inactive)
Bit 5	23	SDRAM5 (Active/Inactive)
Bit 4	22	SDRAM4 (Active/Inactive)
Bit 3	--	Initialize to 0
Bit 2	--	Initialize to 0
Bit 1	--	Initialize to 0
Bit 0	--	Initialize to 0

Byte 2: SDRAM Active/Inactive Register (1 = Active, 0 = Inactive), Default = Active

Bit	Pin #	Description
Bit 7	18	SDRAM9 (Active/Inactive)
Bit 6	11	SDRAM8 (Active/Inactive)
Bit 5	--	Reserved, drive to 0
Bit 4	--	Reserved, drive to 0
Bit 3	--	Reserved, drive to 0
Bit 2	--	Reserved, drive to 0
Bit 1	--	Reserved, drive to 0
Bit 0	--	Reserved, drive to 0

Maximum Ratings

Supply Voltage to Ground Potential	-0.5V to +7.0V	Storage Temperature	-65°C to +150°C
DC Input Voltage (Except BUF_IN).....	-0.5V to $V_{DD} + 0.5V$	Junction Temperature	150°C
DC Input Voltage (BUF_IN).....	-0.5V to +7.0V	Static Discharge Voltage (per MIL-STD-883, Method 3015)	>2000V

Operating Conditions

Parameter	Description	Min.	Max.	Unit
V_{DD}	Supply Voltage	3.135	3.465	V
T_A	Operating Temperature (Ambient Temperature)	0	70	°C
C_L	Load Capacitance	20	30	pF
C_{IN}	Input Capacitance		7	pF
t_{PU}	Power-up time for all V_{DD} s to reach minimum specified voltage (power ramps must be monotonic)	0.05	50	ms

Electrical Characteristics

Parameter	Description	Test Conditions	Min.	Max.	Unit
V_{IL}	Input LOW Voltage ^[1]	Except serial interface pins		0.8	V
V_{ILic}	Input LOW Voltage	For serial interface pins only		0.7	V
V_{IH}	Input HIGH Voltage ^[1]		2.0		V
I_{IL}	Input LOW Current (BUF_IN input)	$V_{IN} = 0V$	-10	10	μA
I_{IL}	Input LOW Current (Except BUF_IN Pin)	$V_{IN} = 0V$		100	μA
I_{IH}	Input HIGH Current	$V_{IN} = V_{DD}$	-10	10	μA
V_{OL}	Output LOW Voltage ^[2]	$I_{OL} = 25\text{ mA}$		0.4	V
V_{OH}	Output HIGH Voltage ^[2]	$I_{OH} = -36\text{ mA}$	2.4		V
I_{DD}	Supply Current ^[2]	Unloaded outputs, 100-MHz		200	mA
I_{DD}	Supply Current	Loaded outputs, 100-MHz		360	mA
I_{DD}	Supply Current ^[2]	Unloaded outputs, 66.67-MHz		150	mA
I_{DD}	Supply Current	Loaded outputs, 66.67-MHz		230	mA
I_{DDs}	Supply Current	BUF_IN= V_{DD} or V_{SS} All other inputs at V_{DD}		500	μA

Notes:

1. BUF_IN input has a threshold voltage of $V_{DD}/2$.
2. Parameter is guaranteed by design and characterization. Not 100% tested in production.

Switching Characteristics^[3]

Parameter	Name	Test Conditions	Min.	Typ.	Max.	Unit
	Maximum Operating Frequency				100	MHz
	Duty Cycle ^[2, 4] = $t_2 \div t_1$	Measured at 1.5V	45.0	50.0	55.0	%
t_3	Rising Edge Rate ^[2]	Measured between 0.4V and 2.4V	0.9	1.5	4.0	V/ns
t_4	Falling Edge Rate ^[2]	Measured between 2.4V and 0.4V	0.9	1.5	4.0	V/ns
t_5	Output to Output Skew ^[2]	All outputs equally loaded		150	250	ps
t_6	SDRAM Buffer LH Prop. Delay ^[2]	Input edge greater than 1 V/ns	1.0	3.5	5.0	ns
t_7	SDRAM Buffer HL Prop. Delay ^[2]	Input edge greater than 1 V/ns	1.0	3.5	5.0	ns
t_8	SDRAM Buffer Enable Delay ^[2]	Input edge greater than 1 V/ns	1.0	5	12	ns
t_9	SDRAM Buffer Disable Delay ^[2]	Input edge greater than 1 V/ns	1.0	20	30	ns

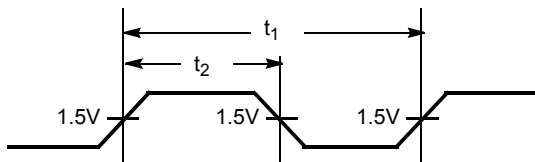
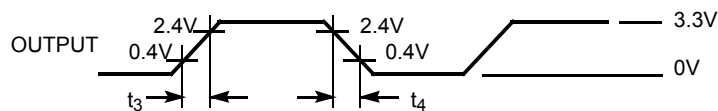
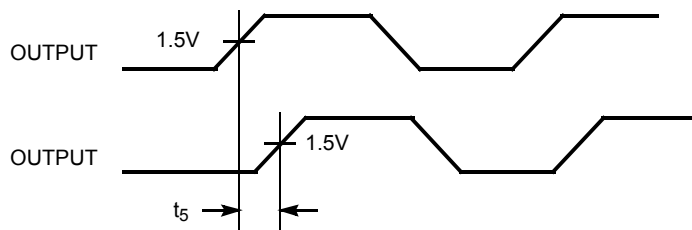
Switching Waveforms
Duty Cycle Timing

All Outputs Rise/Fall Time

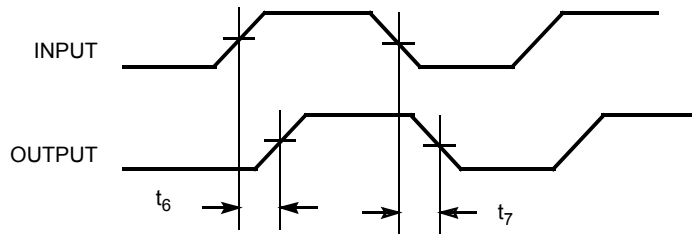
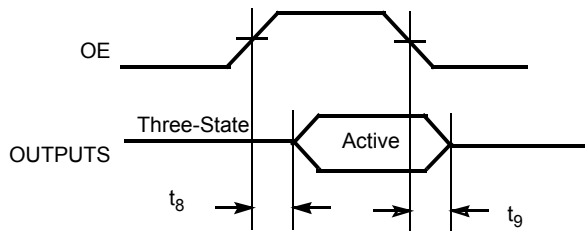
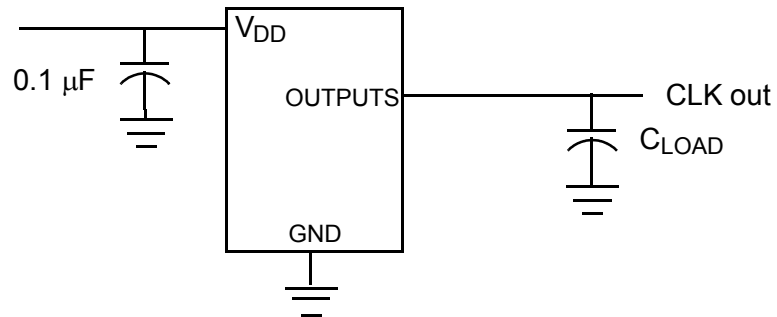
Output-Output Skew

Notes:

3. All parameters specified with loaded outputs.
4. Duty cycle of input clock is 50%. Rising and falling edge rate is greater than 1V/ns

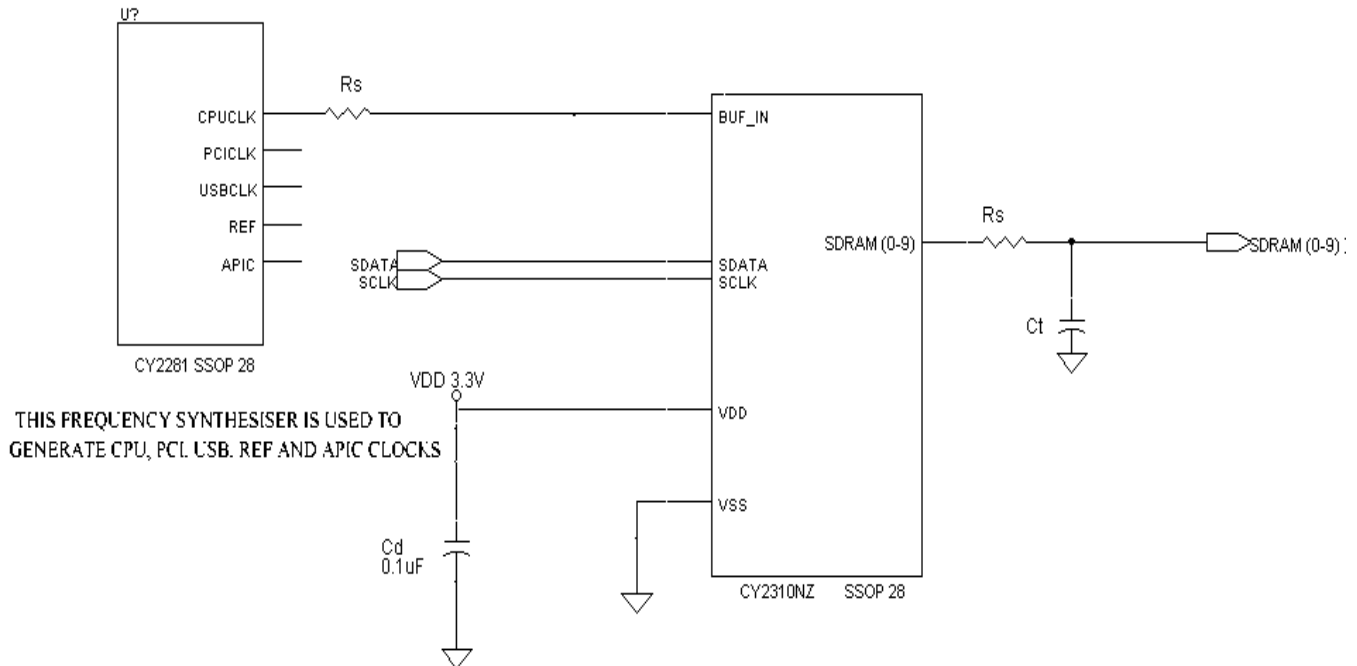
Switching Waveforms (continued)
SDRAM Buffer LH and HL Propagation Delay

SDRAM Buffer Enable and Disable Times

Test Circuit

Application Information

Clock traces must be terminated with either series or parallel termination, as is normally done.



Cd = DECOUPLING CAPACITOR

Ct = OPTIONAL EMI-REDUCING CAPACITORS

Rs = SERIES TERMINATING RESISTORS

Summary

- Surface mount, low-ESR, ceramic capacitors should be used for filtering. Typically, these capacitors have a value of 0.1 μ F. In some cases, smaller value capacitors may be required.
- The value of the series terminating resistor satisfies the following equation, where R_{trace} is the loaded characteristic impedance of the trace, R_{out} is the output impedance of the buffer (typically 25 Ω), and R_{series} is the series terminating resistor.

$$R_{series} > R_{trace} - R_{out}$$
- Footprints must be laid out for optional EMI-reducing capacitors, which should be placed as close to the terminating resistor as is physically possible. Typical values of these capacitors range from 4.7 pF to 22 pF.
- A Ferrite Bead **may** be used to isolate the Board V_{DD} from the clock generator V_{DD} island. Ensure that the Ferrite Bead offers greater than 50 Ω impedance at the clock frequency, under loaded DC conditions. Please refer to the application note "Layout and Termination Techniques for Cypress Clock Generators" for more details.
- If a Ferrite Bead is used, a 10 μ F–22 μ F tantalum bypass capacitor should be placed close to the Ferrite Bead. This capacitor prevents power supply droop during current surges.

Ordering Information

Ordering Code	Package Type	Operating Range
Standard		
CY2310ANZPVC-1	28-pin SSOP	Commercial
CY2310ANZPVC-1T	28-pin SSOP - Tape and Reel	Commercial
Lead-free		
CY2310ANZPVXC-1	28-pin SSOP	Commercial
CY2310ANZPVXC-1T	28-pin SSOP - Tape and Reel	Commercial

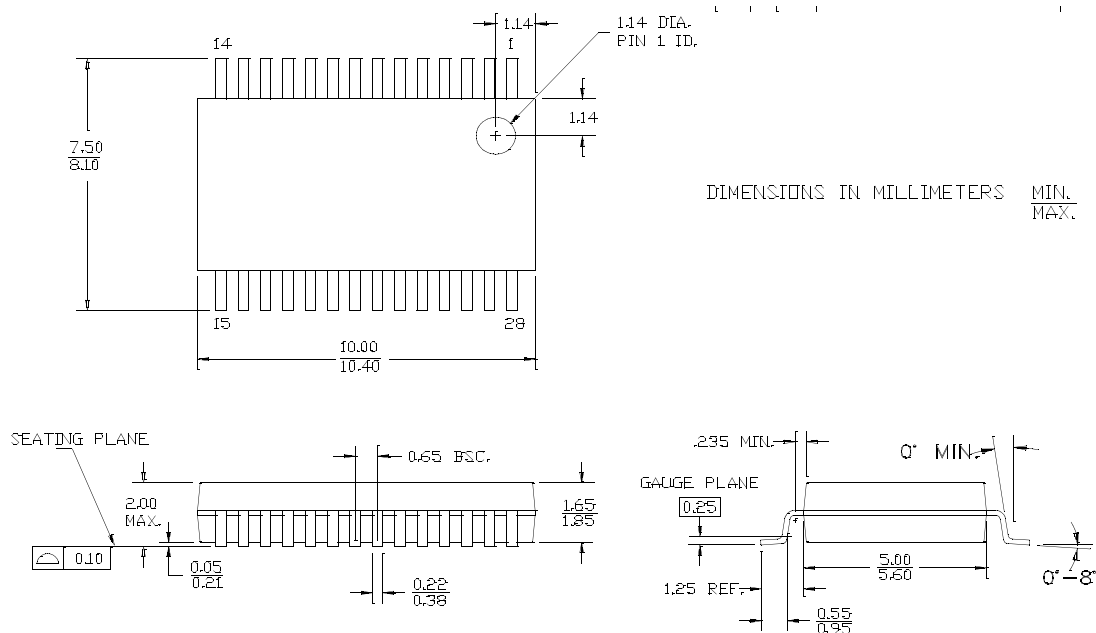
Package Diagram
28-Lead (5.3 mm) Shrunken Small Outline Package O28

51-85079-°C

Pentium II is a registered trademark of Intel Corporation. All products and company names mentioned in this document may be the trademarks of their respective holders.

Document History Page

Document Title: CY2310ANZ 3.3V SDRAM Buffer for Mobile PCs with 4 SO-DIMMs				
Document Number: 38-07142				
REV.	ECN NO.	Issue Date	Orig. of Change	Description of Change
**	110251	11/18/01	DSG	Change from Spec number: 38-00659 to 38-07142
*A	121829	12/14/02	RBI	Power up requirements added to Operating Conditions Information
*B	310555	See ECN	RGL	Added Lead-free Devices



LittleDiode supplies new, hard to find or obsolete electronic components and semiconductors all over the world.

With over two million different components listed you are sure to find the part you need.

Feel free to visit us today at our online store:

LittleDiode.com

Looking forward to providing you with the best possible service.