

Spread Spectrum Clock Generator

Features

- 25- to 100-MHz operating frequency range
- Wide (9) range of spread selections
- Accepts clock and crystal inputs
- Low power dissipation:
 - 56 mW @ Fin = 25 MHz
 - 89 mW @ Fin = 65 MHz
 - 139 mW @ Fin = 100 MHz
- Frequency spread disable function
- Center spread modulation
- Low cycle-to-cycle jitter
- 8-pin SOIC package
- Commercial and Industrial temperature ranges

Applications

- Desktop, notebook, and tablet PCs
- VGA controllers
- LCD panels and monitors
- Printers and multifunction devices (MFP)

Benefits

- Peak electromagnetic interference (EMI) reduction by 8 to 16 dB
- Fast time to market
- Cost reduction

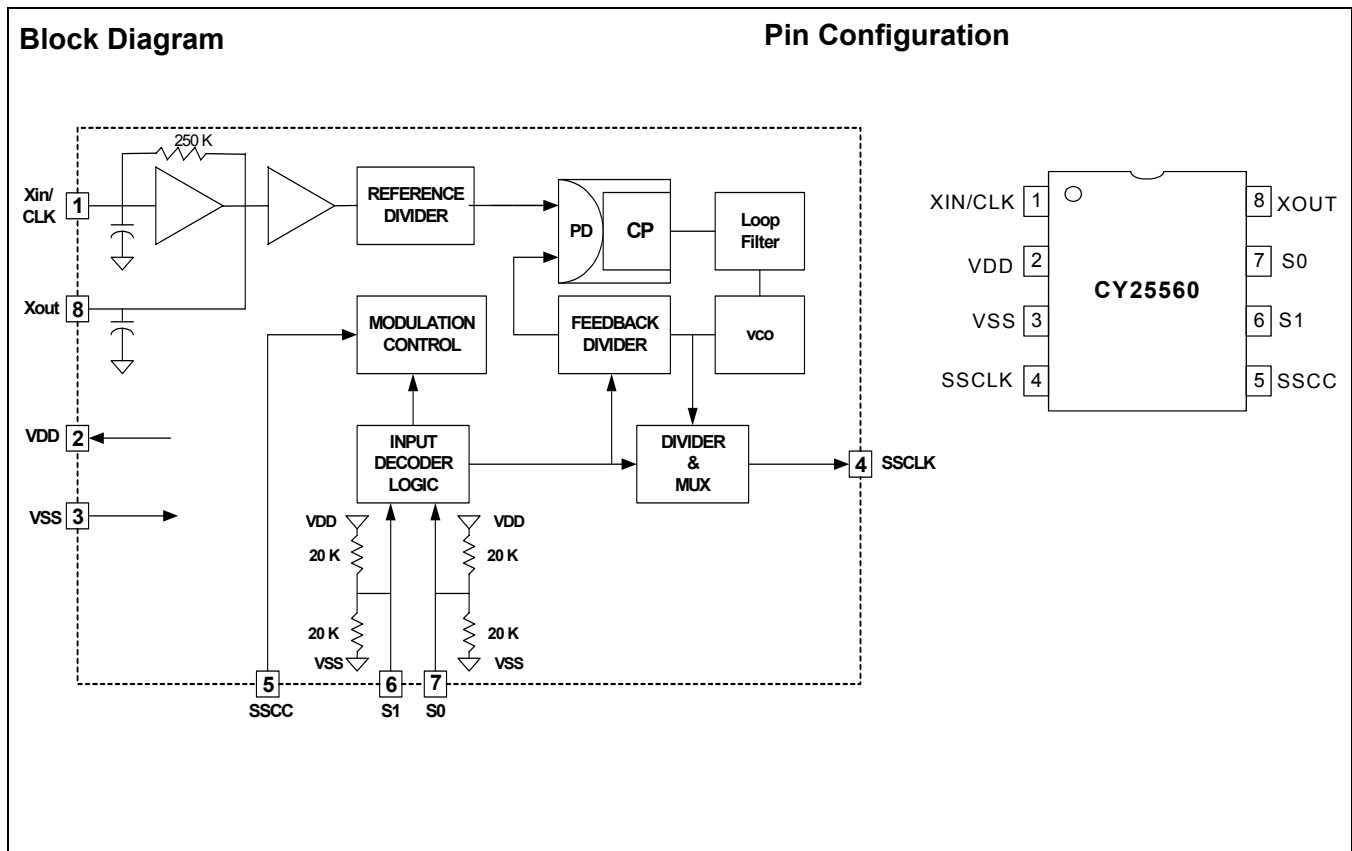

Pin Description

Pin Number	Pin Name	Type	Pin Description
1	Xin/CLK	I	Clock or crystal connection input. Refer to <i>Table 1</i> for input frequency range selection.
2	VDD	P	Positive power supply.
3	GND	P	Power supply ground.
4	SSCLK	O	Modulated clock output which is the same frequency as the input clock or the crystal frequency.
5	SSCC	I	Spread Spectrum Clock Control (Enable/Disable) function. SSCG function is enabled when input is HIGH and disabled when input is LOW. This pin is pulled HIGH internally.
6	S1	I	Tri-level logic input control pin used to select input frequency range and spread percent. Refer to tri-level logic on page 3 for programming details. Pin 6 has internal resistor divider network to V _{DD} and V _{SS} . Refer to Block Diagram on page 1.
7	S0	I	Tri-level logic input control pin used to select input frequency range and spread percent. Refer to tri-level logic on page 3 for programming details. Pin 7 has internal resistor divider network to V _{DD} and V _{SS} . Refer to Block Diagram on page 1.
8	Xout	O	Oscillator output pin connected to crystal. Leave this pin unconnected if an external clock is used to drive X _{IN} /CLK input (pin-1).

General Description

The Cypress CY25560 is a Spread Spectrum Clock Generator (SSCG) IC used for the purpose of reducing EMI found in today's high-speed digital electronic systems.

The CY25560 uses a Cypress proprietary phase-locked loop (PLL) and Spread Spectrum Clock (SSC) technology to synthesize and frequency modulate the input frequency of the reference clock. By frequency modulating the clock, the measured EMI at the fundamental and harmonic frequencies of Clock (SSCLK) is greatly reduced.

This reduction in radiated energy can significantly reduce the cost of complying with regulatory requirements and time to market without degrading the system performance.

The CY25560 is a very simple and versatile device to use. The frequency and spread% range is selected by programming S0 and S1 digital inputs. These inputs use three (3) logic states including High (H), Low (L) and Middle (M) logic levels to select

one of the nine available Spread% ranges. Refer to *Table 1* for programming details.

The CY25560 is optimized for SVGA (40-MHz) and XVGA (65-MHz) Controller clocks and also suitable for the applications where the frequency range is 25 to 100 MHz.

A wide range of digitally selectable spread percentages is made possible by using three-level (High, Low, and Middle) logic at the S0 and S1 digital control inputs.

The output spread (frequency modulation) is symmetrically centered on the input frequency.

Spread Spectrum Clock Control (SSCC) function enables or disables the frequency spread and is provided for easy comparison of system performance during EMI testing.

The CY25560 is available in an eight-pin SOIC package with 0°C to 70°C commercial and -40°C to 85°C Industrial operating temperature ranges.

Table 1. Frequency and Spread% Selection (Center Spread)
25 – 50 MHz (Low Range)

Input Frequency (MHz)	S1=M S0=M (%)	S1=M S0=0 (%)	S1=1 S0=0 (%)	S1=0 S0=0 (%)	S1=0 S0=M (%)
25 – 35	4.3	3.8	3.4	2.9	2.8
35 – 40	3.9	3.5	3.1	2.5	2.4
40 – 45	3.7	3.3	2.8	2.4	2.3
45 – 50	3.4	3.1	2.6	2.2	2.1

Select the Frequency and Center Spread % desired and then set S1, S0 as indicated.

50 – 100 MHz (High Range)

Input Frequency (MHz)	S1=1 S0=M (%)	S1=0 S0=1 (%)	S1=1 S0=1 (%)	S1=M S0=1 (%)
50 – 60	2.9	2.1	1.5	1.2
60 – 70	2.8	2.0	1.4	1.1
70 – 80	2.6	1.8	1.3	1.1
80 – 100	2.4	1.7	1.2	1.0

Select the Frequency and Center Spread % desired and then set S1, S0 as indicated.

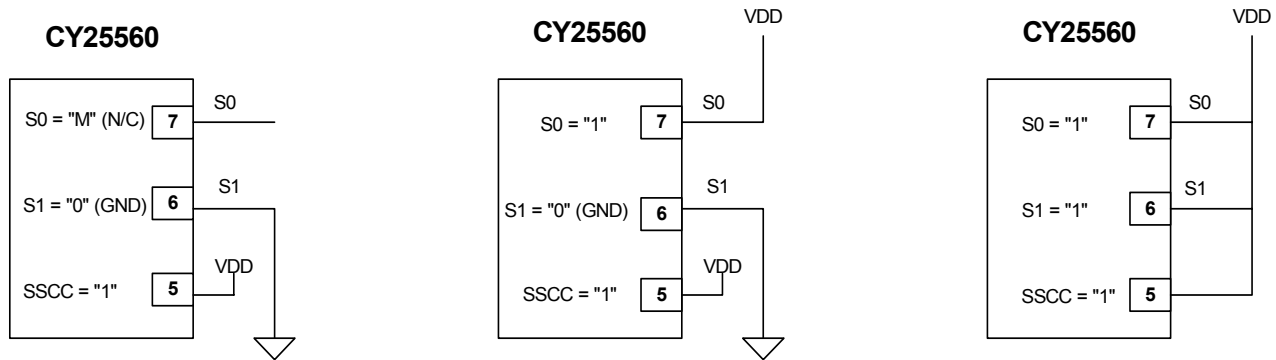
Figure 1. Three-level Logic Examples

Tri-level Logic

With binary logic, four states can be programmed with two control lines whereas three-level logic can program nine logic states using two control lines. Three-level logic in the CY25560 is implemented by defining a third logic state in addition to the standard logic “1” and “0.” Pins 6 and 7 of the CY25560 recognize a logic state by the voltage applied to the respective pin. These states are defined as “0” (Low), “M” (Middle), and “1” (One). Each of these states have a defined voltage range that is interpreted by the CY25560 as a “0”, “M” or “1” logic state. Refer to *Table 2* for voltage ranges for each logic state. The CY25560 has two equal value resistor dividers connected internally to Pins 6 and 7 that produce the default “M” (Middle) state if these pins are left unconnected (NC). Pins 6 and/or 7 can be tied directly to ground or V_{DD} to program a Logic “0” or “1” state, respectively.

SSCG Theory of Operation

The CY25560 is a PLL-type clock generator using a proprietary Cypress design. By precisely controlling the bandwidth of the output clock, the CY25560 becomes a Low-EMI clock generator. The theory and detailed operation of the CY25560 will be discussed in the following sections.

EMI

All digital clocks generate unwanted energy in their harmonics. Conventional digital clocks are square waves with a duty cycle that is very close to 50%. Because of this 50/50 duty cycle, digital clocks generate most of their harmonic energy in the odd harmonics, i.e., third, fifth, seventh, etc. It is possible to reduce the amount of energy contained in the fundamental and odd harmonics by increasing the bandwidth of the fundamental clock frequency. Conventional digital clocks have a very high Q factor, which means that all of the energy at that frequency is concentrated in a very narrow bandwidth, consequently, higher energy peaks. Regulatory agencies test electronic equipment by the amount of peak energy radiated from the equipment. By reducing the peak energy at the fundamental and harmonic frequencies, the equipment under test is able to satisfy agency requirements for EMI. Conventional methods of reducing EMI have been to use shielding, filtering, multilayer PCBs, etc. The CY25560 uses the approach of reducing the peak energy in the clock by increasing the clock bandwidth, and lowering the Q.

SSCG

SSCG uses a patented technology of modulating the clock over a very narrow bandwidth and controlled rate of change, both peak and cycle to cycle. The CY25560 takes a narrow band digital reference clock in the range of 25–100 MHz and produces a clock that sweeps between a controlled start and stop frequency and precise rate of change. To understand what happens to a clock when SSCG is applied, consider a 65-MHz clock with a 50% duty cycle. From a 65-MHz clock we know the following:

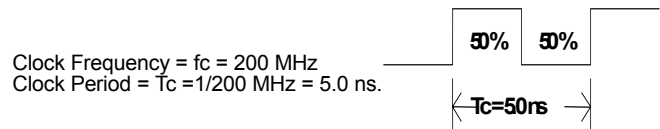

If this clock is applied to the Xin/CLK pin of CY25560, the output clock at pin 4 (SSCLK) will be sweeping back and forth between two frequencies. These two frequencies, F1 and F2, are used to calculate to total amount of spread or bandwidth applied to the reference clock at pin 1. As the clock is making the transition from F1 to F2, the amount of time and sweep waveform play a very important role in the amount of EMI reduction realized from an SSCG clock.

The modulation domain analyzer is used to visualize the sweep waveform and sweep period. *Figure 2* shows the modulation profile of a 65 MHz SSCG clock. Notice that the actual sweep waveform is not a simple sine or sawtooth waveform. *Figure 2* also shows a scan of the same SSCG clock using a spectrum analyzer. In this scan you can see a 6.48-dB reduction in the peak RF energy when using the SSCG clock.

Modulation Rate

Spectrum Spread Clock Generators utilize frequency modulation (FM) to distribute energy over a specific band of frequencies. The maximum frequency of the clock (Fmax) and minimum frequency of the clock (Fmin) determine this band of frequencies. The time required to transition from Fmin to Fmax and back to Fmin is the period of the Modulation Rate, Tmod. Modulation Rates of SSCG clocks are generally referred to in terms of frequency or Fmod = 1/Tmod.

The input clock frequency, Fin, and the internal divider count, Cdiv, determine the Modulation Rate. In some SSCG clock generators, the selected range determines the internal divider count. In other SSCG clocks, the internal divider count is fixed over the operating range of the part. The CY25560 has a fixed divider count of 1166.

Device CY25560 **Cdiv** 1166 (All Ranges)

Example:

Device = CY25560
 Fin = 65 MHz
 Range = S1 = 1, S0 = 0

Then;

Modulation Rate = Fmod = 65 MHz/1166 = 55.7 kHz.

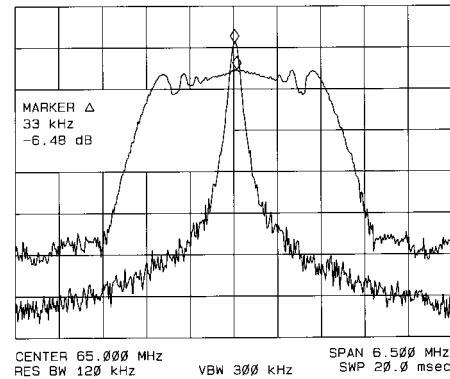
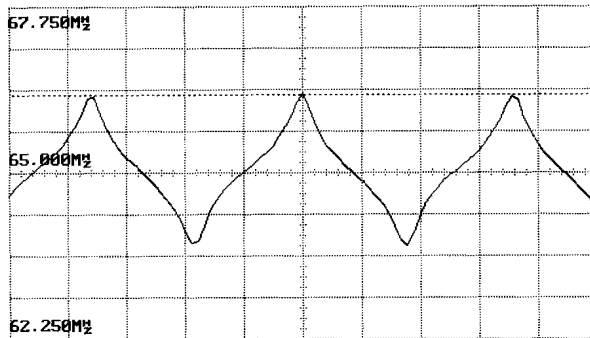

Modulation Profile

Spectrum Analyzer

Figure 2. SSCG Clock, CY25560, Fin = 65 MHz

CY25560 Application Schematic

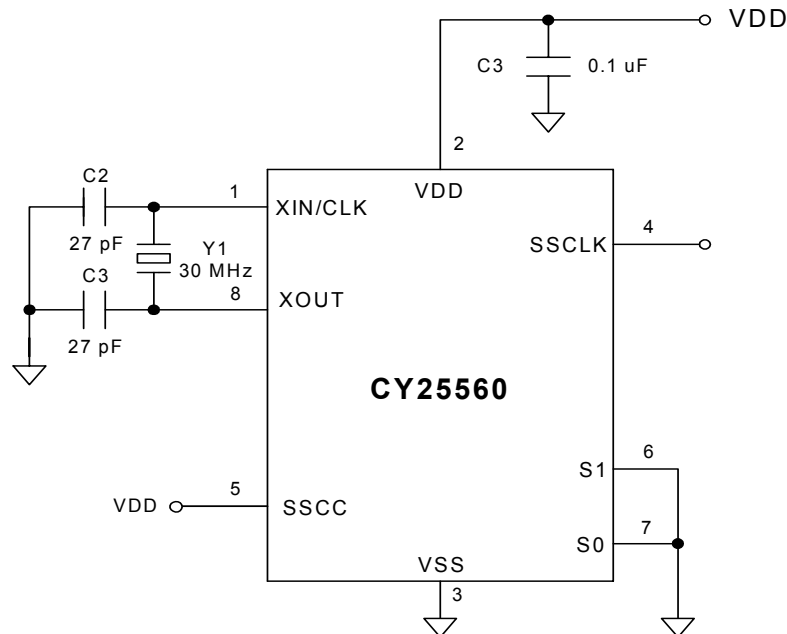

Figure 3. Application Schematic

The schematic in *Figure 3* above demonstrates how the CY25560 is configured in a typical application. This application is shown as using a 30-MHz fundamental crystal. In most applications an external reference clock is used. Apply the

external clock signal at Xin (pin 1) and leave Xout (pin 8) unconnected.

Contact Cypress if higher-order crystal is to be used.

Absolute Maximum Ratings (Commercial Grade)^[1, 2]

Supply Voltage (V_{DD}): -0.5V to +6.0V Storage Temperature -65°C to +150°C
 DC Input Voltage: -0.5V to $V_{DD}+0.5V$ Static Discharge Voltage(ESD) 2,000V-Min
 Junction Temperature -40°C to +140°C
 Operating Temperature: 0°C to 70°C

DC Electrical Characteristics $V_{DD} = 3.3V \pm 10\%$, $T = 0^\circ C$ to $70^\circ C$ and C_L (Pin 4) = 15 pF, unless otherwise noted

Parameter	Description	Conditions	Min.	Typ.	Max.	Unit
V_{DD}	Power Supply Range	$\pm 10\%$	2.97	3.3	3.63	V
V_{IH}	Input High Voltage	S0 and S1 only	$0.85V_{DD}$	V_{DD}	V_{DD}	V
V_{IM}	Input Middle Voltage	S0 and S1 only	$0.40V_{DD}$	$0.50V_{DD}$	$0.60V_{DD}$	V
V_{IL}	Input Low Voltage	S0 and S1 only	0.0	0.0	$0.15V_{DD}$	V
V_{OH}	Output High Voltage	$I_{OH} = 6\text{ ma}$	2.4			V
V_{OL}	Output Low Voltage	$I_{OH} = 6\text{ ma}$			0.4	V
C_{in1}	Input Capacitance	Xin/CLK (Pin 1)	3	4	5	pF
C_{in2}	Input Capacitance	Xout (Pin 8)	6	8	10	pF
C_{in2}	Input Capacitance	S0, S1, SSCC (Pins 7, 6, 5)	3	4	5	pF
I_{DD1}	Power Supply Current	FIN = 25 MHz, CL= 0		17	23	mA
I_{DD2}	Power Supply Current	FIN = 65 MHz, CL= 0		27	41	mA
I_{DD3}	Power Supply Current	FIN = 100 MHz, CL= 0		42	59	mA

Table 2. Electrical Timing Characteristics $V_{DD} = 3.3V \pm 10\%$, $T = 0^\circ C$ to $70^\circ C$ and C_L (Pin 4) = 15 pF, unless otherwise noted

Parameter	Description	Conditions	Min.	Typ.	Max.	Unit
I_{CLKFR}	Input Clock Frequency Range	$V_{DD} = 3.30V$	25		100	MHz
t_F	Clock Rise Time (Pin 4)	SSCLK @ 0.4 – 2.4V	1.0	1.8	2.8	ns
t_R	Clock Fall Time (Pin 4)	SSCLK @ 0.4 – 2.4V	1.0	1.8	2.8	ns
D_{TYin}	Input Clock Duty Cycle	XIN/CLK (Pin 1)	25	50	75	%
D_{TYout}	Output Clock Duty Cycle	SSCLK (Pin 4)	45	50	55	%
J_{CC1}	Cycle-to-Cycle Jitter	Fin = 25–50 MHz, SSCC = 1		150	300	ps
J_{CC2}	Cycle-to-Cycle Jitter	Fin = 50–100 MHz, SSCC = 1		130	200	ps

Notes:

1. Operation at any Absolute Maximum Rating is not implied.
2. Single Power Supply: The voltage on any input or I/O pin cannot exceed the power pin during power up.

Absolute Maximum Conditions (Industrial Grade)^[1, 2]

Supply Voltage (V_{DD}): -0.5V to +6.0V Operating Temperature:..... -40°C to 85°C
 DC Input Voltage:..... -0.5V to $V_{DD}+0.5V$ Storage Temperature..... -65°C to +150°C
 Junction Temperature -40°C to +140°C Static Discharge Voltage(ESD)..... 2,000V-Min

Table 3. DC Electrical Characteristics (Preliminary) $V_{DD} = 3.3V \pm 10\%$, $T = -40^\circ C$ to $85^\circ C$ and C_L (Pin 4) = 15 pF, unless otherwise noted

Parameter	Description	Conditions	Min.	Typ.	Max.	Unit
V_{DD}	Power Supply Range	$\pm 10\%$	2.97	3.3	3.63	V
V_{IH}	Input High Voltage	S0 and S1 only	$0.85V_{DD}$	V_{DD}	V_{DD}	V
V_{IM}	Input Middle Voltage	S0 and S1 only	$0.40V_{DD}$	$0.50V_{DD}$	$0.60V_{DD}$	V
V_{IL}	Input Low Voltage	S0 and S1 only	0.0	0.0	$0.15V_{DD}$	V
V_{OH}	Output High Voltage	$I_{OH} = 6 \text{ ma}$	2.2			V
V_{OL}	Output Low Voltage	$I_{OH} = 6 \text{ ma}$			0.4	V
C_{in1}	Input Capacitance	Xin/CLK (Pin 1)	3	4	5	pF
C_{in2}	Input Capacitance	Xout (Pin 8)	6	8	10	pF
C_{in2}	Input Capacitance	S0, S1, SSCC (Pins 7, 6, 5)	3	4	5	pF
I_{DD1}	Power Supply Current	FIN = 25 MHz, CL= 0		17	24	mA
I_{DD2}	Power Supply Current	FIN = 65 MHz, CL= 0		27	41	mA
I_{DD3}	Power Supply Current	FIN = 100 MHz, CL= 0		42	61	mA

Table 4. Electrical Timing Characteristics (Preliminary) $V_{DD} = 3.3V \pm 10\%$, $T = -40^\circ C$ to $85^\circ C$ and C_L (Pin 4) = 15 pF, unless otherwise noted

Parameter	Description	Conditions	Min.	Typ.	Max.	Unit
f_{CLKFR}	Input Clock Frequency Range	$V_{DD} = 3.30V$	25		100	MHz
t_F	Clock Rise Time (Pin 4)	SSCLK @ 0.4 – 2.4V	1.0	1.8	3.0	ns
t_R	Clock Fall Time (Pin 4)	SSCLK @ 0.4 – 2.4V	1.0	1.8	3.0	ns
D_{TYin}	Input Clock Duty Cycle	XIN/CLK (Pin 1)	25	50	75	%
D_{TYout}	Output Clock Duty Cycle	SSCLK (Pin 4)	45	50	55	%
J_{CC1}	Cycle-to-Cycle Jitter	Fin = 25–50 MHz, SSCC = 1		150	300	ps
J_{CC2}	Cycle-to-Cycle Jitter	Fin = 50–100 MHz, SSCC = 1		130	200	ps

Ordering Information

Part Number	Package Type	Product Flow
CY25560SC	8-pin SOIC	Commercial, 0°C to 70°C
CY25560SCT	8-pin SOIC–Tape and Reel	Commercial, 0°C to 70°C
CY25560SI	8-pin SOIC	Industrial, -40°C to 85°C
CY25560SIT	8-pin SOIC–Tape and Reel	Industrial, -40°C to 85°C
Lead-free		
CY25560SXC	8-pin SOIC	Commercial, 0°C to 70°C
CY25560SXCT	8-pin SOIC–Tape and Reel	Commercial, 0°C to 70°C
CY25560SXI	8-pin SOIC	Industrial, -40°C to 85°C
CY25560SXIT	8-pin SOIC–Tape and Reel	Industrial, -40°C to 85°C

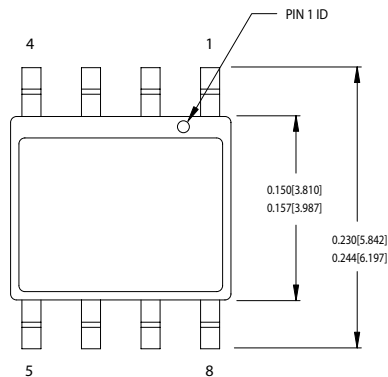
Package Drawing and Dimensions
8-lead (150-Mil) SOIC S8

1. DIMENSIONS IN INCHES[MM] MIN. MAX.
2. PIN 1 ID IS OPTIONAL,
ROUND ON SINGLE LEADFRAME
RECTANGULAR ON MATRIX LEADFRAME
3. REFERENCE JEDEC MS-012
4. PACKAGE WEIGHT 0.07gms

PART #	
S08.15	STANDARD PKG.
SZ08.15	LEAD FREE PKG.

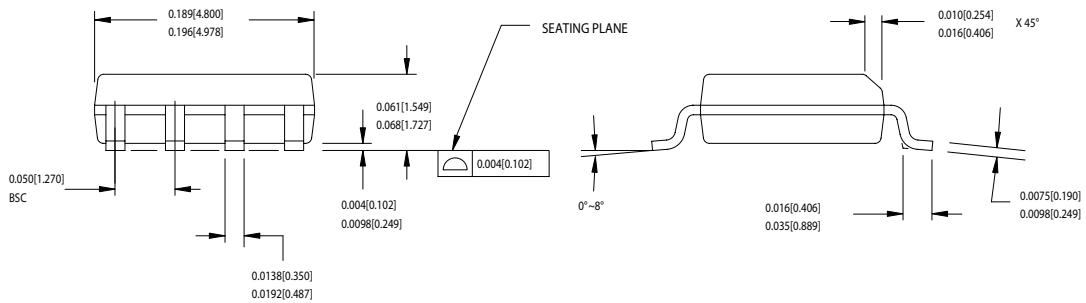

51-85066-°C

All product and company names mentioned in this document are the trademarks of their respective holders.

Document History Page

Document Title:CY25560 Spread Spectrum Clock Generator				
Document Number: 38-07245				
Rev.	ECN No.	Issue Date	Orig. of Change	Description of Change
**	115261	06/12/02	OXC	New Data Sheet
*A	119441	10/17/02	RGL	Corrected the values in the Absolute Maximum Ratings to match the device.
*B	122704	12/30/02	RBI	Added power up requirements to maximum ratings information.
*C	125549	05/15/03	RGL	Added Industrial Temperature Range to the device. Removed V_{OL2} and V_{OH2} spec in the DC specs table Changed IDD Values from 11/17/25 typ and 14/22/34max to 17/27/42 typ and 23/41/59 max Changed T_F/T_R values from 1.3/1.3 typ and 1.6/1.6 max to 1.8/1.8 typ and 2.8/2.8 max in the Electrical Char. table. Changed $J_{CC1/2}$ values from 200/250 typ and 250/300 max to 150/130 typ to 300/200 max in the Electrical Char. table. Changed the low power dissipation from 36/56/82mW to 56/89/139mW respectively. Changed the low cycle-to-cycle jitter from 195/175/100ps-typ to 450/225/150 ps-max
*D	314293	See ECN	RGL	Added Lead-free devices



LittleDiode supplies new, hard to find or obsolete electronic components and semiconductors all over the world.

With over two million different components listed you are sure to find the part you need.

Feel free to visit us today at our online store:

LittleDiode.com

Looking forward to providing you with the best possible service.