



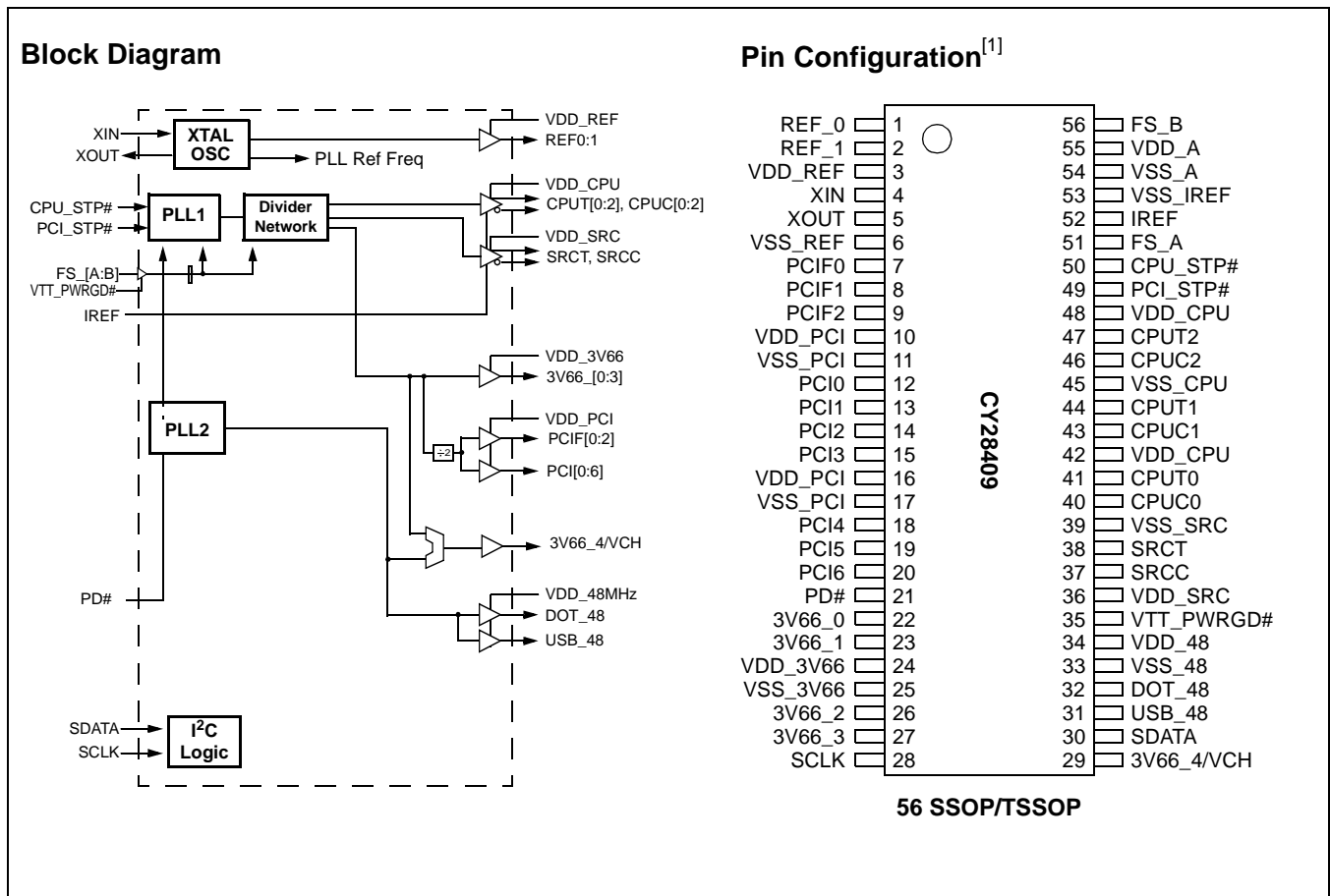
# Clock Synthesizer with Differential SRC and CPU Outputs

## Features

- Supports Intel® Pentium® 4-type CPUs
- Selectable CPU frequencies
- 3.3V power supply
- Ten copies of PCI clocks
- Five copies of 3V66 with one optional VCH
- Two copies 48-MHz USB clocks

- Three differential CPU clock pairs
- One differential SRC clock
- I<sup>2</sup>C support with readback capabilities
- Ideal Lexmark Spread Spectrum profile for maximum EMI reduction
- 56-pin SSOP and TSSOP packages

CPU	SRC	3V66	PCI	REF	48M
x 3	x 1	x 5	x 10	x 2	x 2



**Note:**

1. Signals marked with [\*] and [\*\*] have internal pull-up and pull-down resistors, respectively.

**Pin Description**

Pin No.	Name	Type	Description
1, 2	REF(0:1)	O, SE	<b>Reference Clock.</b> 3.3V 14.318-Mz clock output.
4	XIN	I	<b>Crystal Connection or External Reference Frequency Input.</b> This pin has dual functions. It can be used as an external 14.318-MHz crystal connection or as an external reference frequency input.
5	XOUT	O, SE	<b>Crystal Connection.</b> Connection for an external 14.318-MHz crystal output.
41,44,47	CPUT(0:2)	O, DIF	<b>CPU Clock Output.</b> Differential CPU clock outputs. See <i>Table 1</i> for frequency configuration
40,43,46	CPUC(0:2)	O, DIF	<b>CPU Clock Output.</b> Differential CPU clock outputs. See <i>Table 1</i> for frequency configuration
38, 37	SRCT, SRCC	O, DIF	<b>Differential serial reference clock.</b>
22,23,26,27	3V66(0:3)	O, SE	<b>66-MHz Clock Output.</b> 3.3V 66-MHz clock from internal VCO.
29	3V66_4VCH	O, SE	<b>48-/66-MHz Clock Output.</b> 3.3V selectable through SMBus to be 66 or 48 MHz.
7,8,9	PCIF(0:2)	O, SE	<b>Free-running PCI Output.</b> 33-MHz clocks divided down from 3V66.
12,13,14, 15,18,19,20	PCI(0:6)	O, SE	<b>PCI Clock Output.</b> 33-MHz clocks divided down from 3V66.
31,	USB_48	O, SE	<b>Fixed 48-MHz clock output.</b>
32	DOT_48	O, SE	<b>Fixed 48-MHz clock output.</b>
51,56	FS_A, FS_B	I	<b>3.3V LVTTTL input for CPU frequency selection.</b>
52	IREF	I	<b>Current Reference.</b> A precision resistor is attached to this pin which is connected to the internal current reference.
21	PD#	I, PU	<b>3.3V LVTTTL input for PowerDown# active low.</b>
50	CPU_STP#	I, PU	<b>3.3V LVTTTL input for CPU_STP# active low.</b>
49	PCI_STP#	I, PU	<b>3.3V LVTTTL input for PCI_STP# active low.</b>
35	VTT_PWRGD#	I	<b>3.3V LVTTTL input is a level sensitive strobe used to latch the FS_A and FS_B inputs (active low).</b>
30	SDATA	I/O	<b>SMBus-compatible SDATA.</b>
28	SCLK	I	<b>SMBus-compatible SCLOCK.</b>
53	VSS_IREF	GND	<b>Ground for current reference.</b>
55	VDD_A	PWR	<b>3.3V power supply for PLL.</b>
54	VSS_A	GND	<b>Ground for PLL.</b>
42,48	VDD_CPU	PWR	<b>3.3V power supply for outputs.</b>
45	VSS_CPU	GND	<b>Ground for outputs.</b>
36	VDD_SRC	PWR	<b>3.3V power supply for outputs.</b>
39	VSS_SRC	GND	<b>Ground for outputs.</b>
34	VDD_48	PWR	<b>3.3V power supply for outputs.</b>
33	VSS_48	GND	<b>Ground for outputs.</b>
10,16	VDD_PCI	PWR	<b>3.3V power supply for outputs.</b>
11,17	VSS_PCI	GND	<b>Ground for outputs.</b>
24	VDD_3V66	PWR	<b>3.3V power supply for outputs.</b>
25	VSS_3V66	GND	<b>Ground for outputs.</b>
3	VDD_REF	PWR	<b>3.3V power supply for outputs.</b>
6	VSS_REF	GND	<b>Ground for outputs.</b>

## Frequency Select Pins (FS\_A, FS\_B)

Host clock frequency selection is achieved by applying the appropriate logic levels to FS\_A and FS\_B inputs prior to VTT\_PWRGD# assertion (as seen by the clock synthesizer). Upon VTT\_PWRGD# being sampled low by the clock chip (indicating processor VTT voltage is stable), the clock chip samples the FS\_A and FS\_B input values. For all logic levels of FS\_A and FS\_B except MID, VTT\_PWRGD# employs a one-shot functionality in that once a valid low on

VTT\_PWRGD# has been sampled low, all further VTT\_PWRGD#, FS\_A and FS\_B transitions will be ignored. In the case where FS\_B is at mid level when VTT\_PWRGD# is sampled low, the clock chip will assume "Test Clock Mode". Once "Test Clock Mode" has been invoked, all further FS\_B transitions will be ignored and FS\_A will asynchronously select between the Hi-Z and REF/N mode. Exiting test mode is accomplished by cycling power with FS\_B in a high or low state.

**Table 1. Frequency Select Table (FS\_A FS\_B)**

FS_A	FS_B	CPU	SRC	3V66	PCIF/PCI	REF0	REF1	USB/DOT
0	0	100 MHz	100/200 MHz	66 MHz	33 MHz	14.3 MHz	14.31 MHz	48 MHz
0	MID	REF/N	REF/N	REF/N	REF/N	REF/N	REF/N	REF/N
0	1	200 MHz	100/200 MHz	66 MHz	33 MHz	14.3 MHz	14.31 MHz	48 MHz
1	0	133 MHz	100/200 MHz	66 MHz	33 MHz	14.3 MHz	14.31 MHz	48 MHz
1	MID	Hi-Z	Hi-Z	Hi-Z	Hi-Z	Hi-Z	Hi-Z	Hi-Z

**Table 2. Frequency Select Table (FS\_A FS\_B) SMBus Bit 5 of Byte 6 = 1**

FS_A	FS_B	CPU	SRC	3V66	PCIF/PCI	REF0	REF1	USB/DOT
0	0	200 MHz	100/200 MHz	66 MHz	33 MHz	14.3 MHz	14.31 MHz	48 MHz
0	1	400 MHz	100/200 MHz	66 MHz	33 MHz	14.3 MHz	14.31 MHz	48 MHz
1	0	266 MHz	100/200 MHz	66 MHz	33 MHz	14.3 MHz	14.31 MHz	48 MHz

## Serial Data Interface

To enhance the flexibility and function of the clock synthesizer, a two-signal serial interface is provided. Through the Serial Data Interface, various device functions, such as individual clock output buffers, can be individually enabled or disabled. The registers associated with the Serial Data Interface initialize to their default setting upon power-up, and therefore use of this interface is optional. Clock device register changes are normally made upon system initialization, if any are required. The interface cannot be used during system operation for power management functions.

## Data Protocol

The clock driver serial protocol accepts byte write, byte read, block write, and block read operations from the controller. For block write/read operation, the bytes must be accessed in sequential order from lowest to highest byte (most significant bit first) with the ability to stop after any complete byte has been transferred. For byte write and byte read operations, the system controller can access individually indexed bytes. The offset of the indexed byte is encoded in the command code, as described in *Table 3*.

The block write and block read protocol is outlined in *Table 4* while *Table 5* outlines the corresponding byte write and byte read protocol. The slave receiver address is 11010010 (D2h).

**Table 3. Command Code Definition**

Bit	Description
7	0 = Block read or block write operation, 1 = Byte read or byte write operation
(6:0)	Byte offset for byte read or byte write operation. For block read or block write operations, these bits should be '0000000'

**Table 4. Block Read and Block Write Protocol**

Block Write Protocol		Block Read Protocol	
Bit	Description	Bit	Description
1	Start	1	Start
2:8	Slave address – 7 bits	2:8	Slave address – 7 bits
9	Write = 0	9	Write = 0
10	Acknowledge from slave	10	Acknowledge from slave
11:18	Command Code – 8 Bit '00000000' stands for block operation	11:18	Command Code – 8 Bit '00000000' stands for block operation
19	Acknowledge from slave	19	Acknowledge from slave

**Table 4. Block Read and Block Write Protocol(continued)**

Block Write Protocol		Block Read Protocol	
Bit	Description	Bit	Description
20:27	Byte Count – 8 bits	20	Repeat start
28	Acknowledge from slave	21:27	Slave address – 7 bits
29:36	Data byte 1 – 8 bits	28	Read = 1
37	Acknowledge from slave	29	Acknowledge from slave
38:45	Data byte 2 – 8 bits	30:37	Byte count from slave – 8 bits
46	Acknowledge from slave	38	Acknowledge from master
....	.....	39:46	Data byte from slave – 8 bits
....	Data Byte (N-1) –8 bits	47	Acknowledge from master
....	Acknowledge from slave	48:55	Data byte from slave – 8 bits
....	Data Byte N –8 bits	56	Acknowledge from master
....	Acknowledge from slave	....	Data byte N from slave – 8 bits
....	Stop	....	Acknowledge from master
		....	Stop

**Table 5. Byte Read and Byte Write protocol**

Byte Write Protocol		Byte Read Protocol	
Bit	Description	Bit	Description
1	Start	1	Start
2:8	Slave address – 7 bits	2:8	Slave address – 7 bits
9	Write = 0	9	Write = 0
10	Acknowledge from slave	10	Acknowledge from slave
11:18	Command Code – 8 bits '100xxxxx' stands for byte operation, bits[4:0] of the command code represents the offset of the byte to be accessed	11:18	Command Code – 8 bits '100xxxxx' stands for byte operation, bits[4:0] of the command code represents the offset of the byte to be accessed
19	Acknowledge from slave	19	Acknowledge from slave
20:27	Data byte from master – 8 bits	20	Repeat start
28	Acknowledge from slave	21:27	Slave address – 7 bits
29	Stop	28	Read = 1
		29	Acknowledge from slave
		30:37	Data byte from slave – 8 bits
		38	Acknowledge from master
		39	Stop

**Control Registers**

**Byte 0:Control Register 0**

Bit	@Pup	Name	Description
7	0	Reserved	Reserved, Set = 0
6	1	PCIF PCI	PCI Drive Strength Override 0 = Force All PCI and PCIF Outputs to Low Drive Strength 1 = Force All PCI and PCIF Outputs to High Drive Strength
5	0	Reserved	Reserved, Set = 0
4	0	Reserved	Reserved, Set = 0

**Byte 0: Control Register 0** (continued)

Bit	@Pup	Name	Description
3	Externally Selected	PCI_STP#	PCI_STP# reflects the current value of the external PCI_STP# pin. 0 = PCI_STP# pin is low.
2	Externally Selected	CPU_STP#	CPU_STP# reflects the current value of the external CPU_STP# pin. 0 = CPU_STP# pin is low.
1	Externally Selected	FS_B	FS_B reflects the value of the FS_B pin sampled on power-up.
0	Externally Selected	FS_A	FS_A reflects the value of the FS_A pin sampled on power-up.

**Byte 1: Control Register 1**

Bit	@Pup	Name	Description
7	0	SRCT, SRCC	Allows control of SRCT/C with assertion of PCI_STP# or SW PCI_STP 0 = Free Running, 1 = Stopped with PCI_STP#
6	1	SRCT, SRCC	SRCT/C Output Enable; 0 = Disabled (Hi-z), 1 = Enabled
5	1	Reserved	Reserved, Set = 1
4	1	Reserved	Reserved, Set = 1
3	1	Reserved	Reserved, Set = 1
2	1	CPUT2, CPUC2	CPUT/C2 Output Enable; 0 = Disabled (Hi-z), 1 = Enabled
1	1	CPUT1, CPUC1	CPUT/C1 Output Enable; 0 = Disabled (Hi-z), 1 = Enabled
0	1	CPUT0, CPUC0	CPUT/C0 Output Enable; 0 = Disabled (Hi-z), 1 = Enabled

**Byte 2: Control Register 2**

Bit	@Pup	Name	Description
7	0	SRCT, SRCC	SRCT/C Pwrdown Drive Mode 0 = Driven during power-down, 1 = Three-state during power-down
6	0	SRCT, SRCC	SRCT/C Stop Drive Mode 0 = Driven during PCI_STP, 1 = Three-state during PCI_STP
5	0	CPUT2, CPUC2	CPUT/C2 Pwrdown Drive Mode 0 = Driven during power-down, 1 = Three-state during power-down
4	0	CPUT1, CPUC1	CPUT/C1 Pwrdown Drive Mode 0 = Driven during power 'down, 1 = Three-state during power-down
3	0	CPUT0, CPUC0	CPUT/C0 Pwrdown Drive Mode 0 = Driven during power-down, 1 = Three-state during power-down
2	0	CPUT2, CPUC2	CPUT/C2 stop Drive Mode 0 = Driven when stopped, 1 = Three-state when stopped
1	0	CPUT1, CPUC1	CPUT/C1 stop Drive Mode 0 = Driven when stopped, 1 = Three-state when stopped
0	0	CPUT0, CPUC0	CPUT/C0 stop Drive Mode 0 = Driven when stopped, 1 = Three-state when stopped

**Byte 3: Control Register 3**

Bit	@Pup	Name	Description
7	1	SW PCI STOP	SW PCI_STP Function 0= PCI_STP assert, 1= PCI_STP deassert When this bit is set to 0, all STOPPABLE PCI, PCIF and SRC outputs will be stopped in a synchronous manner with no short pulses. When this bit is set to 1, all STOPPED PCI, PCIF and SRC outputs will resume in a synchronous manner with no short pulses.
6	1	PCI6	PCI6 Output Enable 0 = Disabled, 1 = Enabled

**Byte 3: Control Register 3**

Bit	@Pup	Name	Description
5	1	PCI5	PCI5 Output Enable 0 = Disabled, 1 = Enabled
4	1	PCI4	PCI4 Output Enable 0 = Disabled, 1 = Enabled
3	1	PCI3	PCI3 Output Enable 0 = Disabled, 1 = Enabled
2	1	PCI2	PCI2 Output Enable 0 = Disabled, 1 = Enabled
1	1	PCI1	PCI1 Output Enable 0 = Disabled, 1 = Enabled
0	1	PCI0	PCI0 Output Enable 0 = Disabled, 1 = Enabled

**Byte 4: Control Register 4**

Bit	@Pup	Name	Description
7	0	USB_48	USB_48 Drive Strength 0 = High drive strength, 1 = Low drive strength
6	1	USB_48	USB_48 Output Enable 0 = Disabled, 1 = Enabled
5	0	PCIF2	Allow control of PCIF2 with assertion of PCI_STP# or SW PCI_STP 0 = Free Running, 1 = Stopped with PCL_STP#
4	0	PCIF1	Allow control of PCIF1 with assertion of PCI_STP# or SW PCI_STP 0 = Free Running, 1 = Stopped with PCL_STP#
3	0	PCIF0	Allow control of PCIF0 with assertion of PCI_STP# or SW PCI_STP 0 = Free Running, 1 = Stopped with PCL_STP#
2	1	PCIF2	PCIF2 Output Enable 0 = Disabled, 1 = Enabled
1	1	PCIF1	PCIF1 Output Enable 0 = Disabled, 1 = Enabled
0	1	PCIF0	PCIF0 Output Enable 0 = Disabled, 1 = Enabled

**Byte 5: Control Register 5**

Bit	@Pup	Name	Description
7	1	DOT_48	DOT_48 Output Enable 0 = Disabled, 1 = Enabled
6	1	Reserved	Reserved, Set = 1
5	0	3V66_4/VCH	VCH Select 66 MHz/48 MHz 0 = 3V66 mode, 1 = VCH (48 MHz) mode
4	1	3V66_4/VCH	3V66_4/VCH Output Enable 0 = Disabled, 1 = Enabled
3	1	3V66_3	3V66_3 Output Enable 0 = Disabled, 1 = Enabled
2	1	3V66_2	3V66_2 Output Enable 0 = Disabled, 1 = Enabled
1	1	3V66_1	3V66_1 Output Enable 0 = Disabled, 1 = Enabled
0	1	3V66_0	3V66_0 Output Enable 0 = Disabled, 1 = Enabled

**Byte 6: Control Register 6**

Bit	@Pup	Name	Description
7	0	Reserved	Reserved, Set = 0
6	0	Reserved	Reserved, Set = 0
5	0	CPUC0, CPUT0 CPUC1, CPUT1 CPUC2, CPUT2	FS_A & FS_B Operation 0 = Normal, 1 = Test mode
4	0	SRCT, SRCC	SRC Frequency Select 0 = 100Mhz, 1 = 200MHz
3	0	PCIF PCI 3V66 SRCT,SRCC CPUT_ITP,CPUC_ITP	Spread Spectrum Mode 0 = down (default), 1 = center
2	0	PCIF PCI 3V66 SRCT,SRCC CPUT_ITP,CPUC_ITP	Spread Spectrum Enable 0 = Spread Off, 1 = Spread On
1	1	REF_1	REF_1 Output Enable 0 = Disabled, 1 = Enabled
0	1	REF_0	REF_0 Output Enable 0 = Disabled, 1 = Enabled

**Byte 7: Vendor ID**

Bit	@Pup	Name	Description
7	0	Revision ID Bit 3	Revision ID Bit 3
6	1	Revision ID Bit 2	Revision ID Bit 2
5	0	Revision ID Bit 1	Revision ID Bit 1
4	0	Revision ID Bit 0	Revision ID Bit 0
3	1	Vendor ID Bit 3	Vendor ID Bit 3
2	0	Vendor ID Bit 2	Vendor ID Bit 2
1	0	Vendor ID Bit 1	Vendor ID Bit 1
0	0	Vendor ID Bit 0	Vendor ID Bit 0

**Crystal Recommendations**

The CY28409 requires a **Parallel Resonance Crystal**. Substituting a series resonance crystal will cause the CY28409 to operate at the wrong frequency and violate the ppm specification. For most applications there is a 300-ppm frequency shift between series and parallel crystals due to incorrect loading.

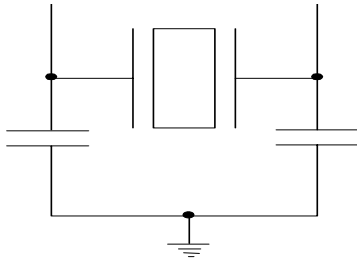
**Table 6. Crystal Recommendations**

Frequency (Fund)	Cut	Loading	Load Cap	Drive (max.)	Shunt Cap (max.)	Motional (max.)	Tolerance (max.)	Stability (max.)	Aging (max.)
14.31818 MHz	AT	Parallel	20 pF	0.1 mW	5 pF	0.016 pF	50 ppm	50 ppm	5 ppm

**Crystal Loading**

Crystal loading plays a critical role in achieving low ppm performance. To realize low ppm performance, the total capacitance the crystal will see must be considered to calculate the appropriate capacitive loading (CL).

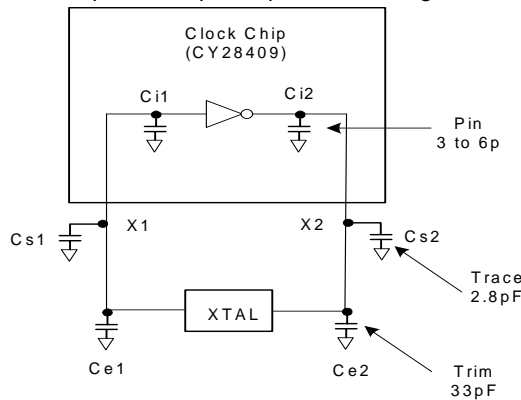
The following diagram shows a typical crystal configuration using the two trim capacitors. An important clarification for the following discussion is that the trim capacitors are in series with the crystal not parallel. It's a common misconception that load capacitors are in parallel with the crystal and should be approximately equal to the load capacitance of the crystal. This is **not true**.



**Figure 1. Crystal Capacitive Clarification**

**Calculating Load Capacitors**

In addition to the standard external trim capacitors, trace capacitance and pin capacitance must also be considered to correctly calculate crystal loading. As mentioned previously, the capacitance on each side of the crystal is in series with the crystal. This means the total capacitance on each side of the crystal must be twice the specified crystal load capacitance (CL). While the capacitance on each side of the crystal is in series with the crystal, trim capacitors (Ce1,Ce2) should be calculated to provide equal capacitive loading on both sides.



**Figure 2. Crystal Loading Example**

Use the following formulas to calculate the trim capacitor values fro Ce1 and Ce2.

**Load Capacitance (each side)**

$$C_e = 2 * CL - (C_s + C_i)$$

**Total Capacitance (as seen by the crystal)**

$$CL_e = \frac{1}{\left( \frac{1}{C_{e1} + C_{s1} + C_{i1}} + \frac{1}{C_{e2} + C_{s2} + C_{i2}} \right)}$$

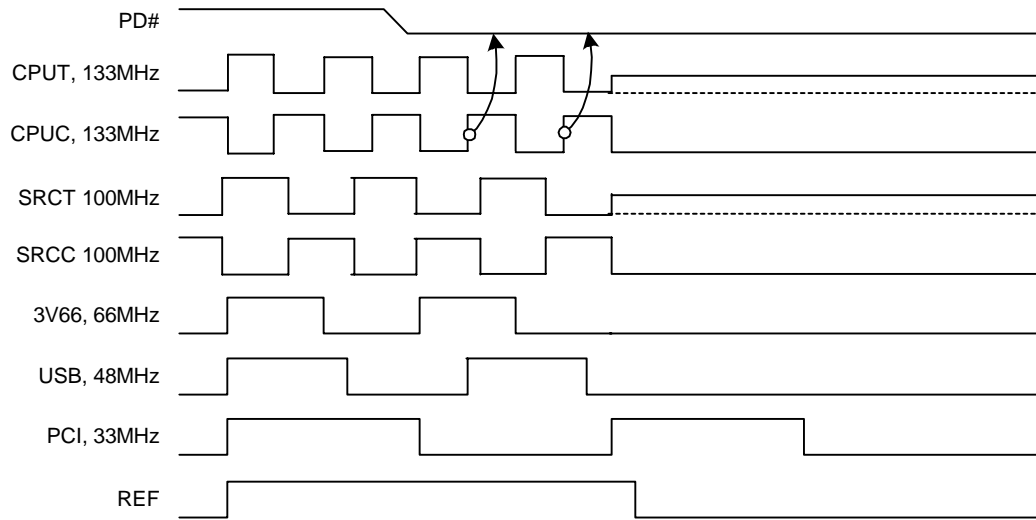
- CL.....Crystal load capacitance
- CL<sub>e</sub> ..... Actual loading seen by crystal using standard value trim capacitors
- C<sub>e</sub> ..... External trim capacitors
- C<sub>s</sub> ..... Stray capacitance (terraced)
- C<sub>i</sub> ..... Internal capacitance (lead frame, bond wires etc.)

**PD# (Power-down) Clarification**

The PD# (Power-down) pin is used to shut off ALL clocks prior to shutting off power to the device. PD# is an asynchronous active LOW input. This signal is synchronized internally to the device powering down the clock synthesizer. PD# is an asynchronous function for powering up the system. When PD# is low, all clocks are driven to a LOW value and held there and the VCO and PLLs are also powered down. All clocks are shut down in a synchronous manner so as not to cause glitches while changing to the low 'stopped' state.

**PD# Assertion**

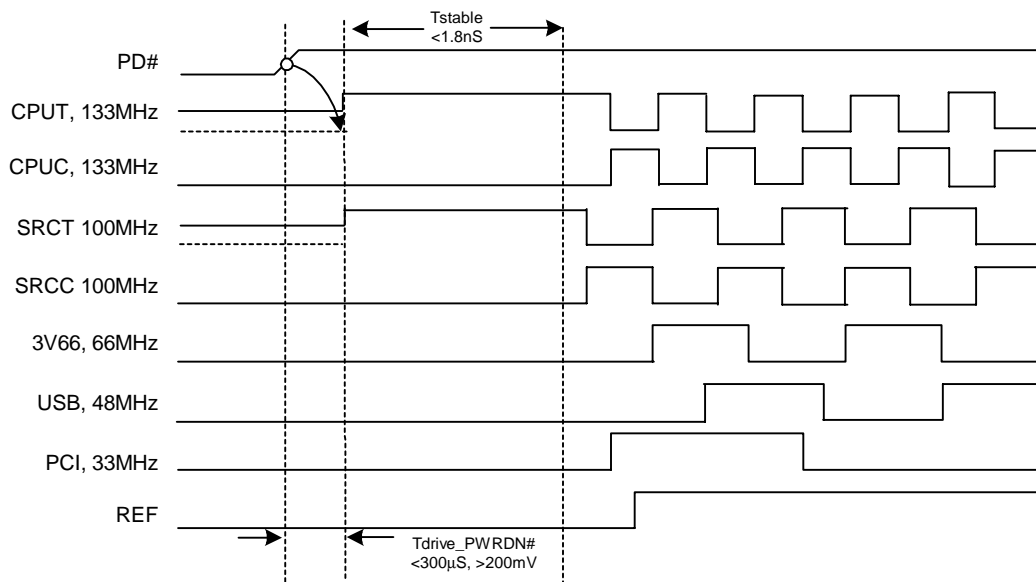
When PD# is sampled low by two consecutive rising edges of the CPUC clock then all clock outputs (except CPU) clocks must be held low on their next high to low transition. CPU clocks must be held with CPU clock pin driven high with a value of 2 x Iref and CPUC undriven. Due to the state of internal logic, stopping and holding the REF clock outputs in the LOW state may require more than one clock cycle to complete



**Figure 3. Power-down Assertion Timing Waveform**

**PD# Deassertion**

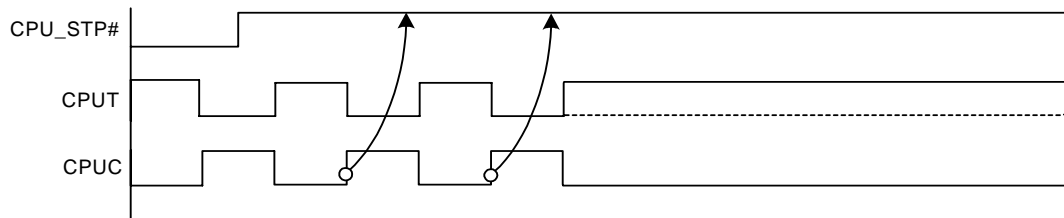
The power-up latency between PD# rising to a valid logic '1' level and the starting of all clocks is less than 1.8 ms.



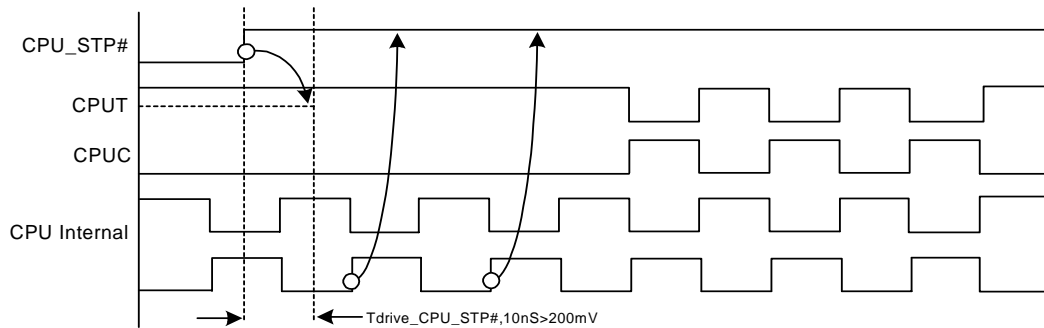
**Figure 4. Power-down Deassertion Timing Waveform**

**CPU\_STP# Assertion**

The CPU\_STP# signal is an active low input used for synchronous stopping and starting the CPU output clocks while the rest of the clock generator continues to function. When the CPU\_STP# pin is asserted, all CPU outputs that are set with the SMBus configuration to be stoppable via assertion of CPU\_STP# will be stopped after being sampled by two rising edges of the internal CPUC clock. The final states of the stopped CPU signals are CPUC = HIGH and CPUC = LOW. There is no change to the output drive current values during the stopped state. The CPUC is driven HIGH with a current value equal to (Mult 0 'select') x (Iref), and the CPUC signal will not be driven. Due to the external pull-down circuitry, CPUC will be LOW during this stopped state.

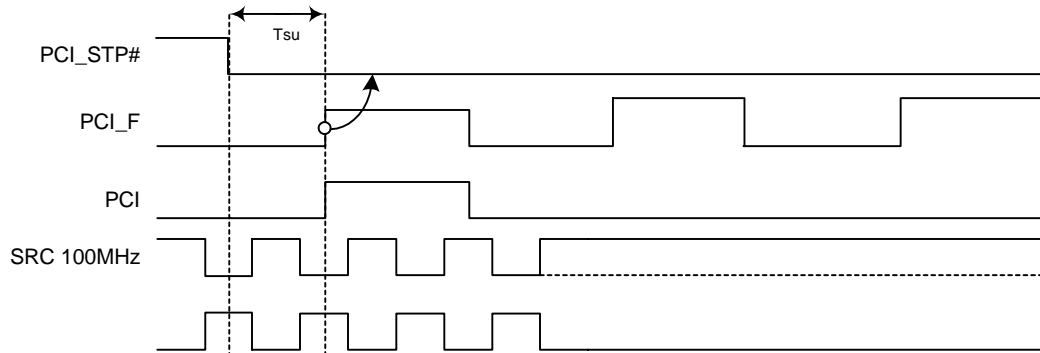

**Figure 5. CPU\_STP# Assertion Waveform**
**CPU\_STP# Deassertion**

The de-assertion of the CPU\_STP# signal will cause all CPU outputs that were stopped to resume normal operation in a synchronous manner. Synchronous manner meaning that no short or stretched clock pulses will be produced when the clock resumes. The maximum latency from the deassertion to active outputs is no more than two CPU clock cycles.


**Figure 6. CPU\_STP# Deassertion Waveform**

**PCI\_STP# Assertion<sup>[2]</sup>**

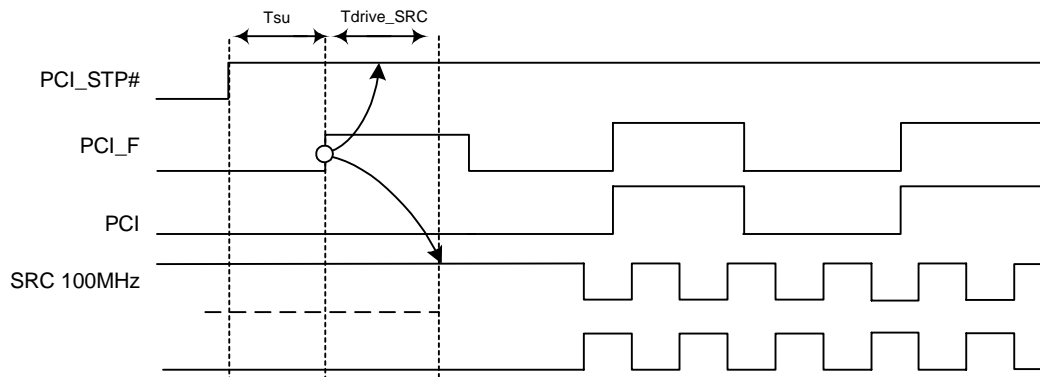
The PCI\_STP# signal is an active LOW input used for synchronous stopping and starting the PCI outputs while the rest of the clock generator continues to function. The set-up time for capturing PCI\_STP# going LOW is 10 ns ( $t_{SU}$ ). (See *Figure 7.*) The PCIF clocks will not be affected by this pin if their corresponding control bit in the SMBus register is set to allow them to be free-running.



**Figure 7. PCI\_STP# Assertion Waveform**

**PCI\_STP# Deassertion**

The deassertion of the PCI\_STP# signal will cause all PCI and stoppable PCIF clocks to resume running in a synchronous manner within two PCI clock periods after PCI\_STP# transitions to a high level.



**Figure 8. PCI\_STP# Deassertion Waveform**

**Note:**

2. The PCI STOP function is controlled by two inputs. One is the device PCI\_STP# pin number 34 and the other is SMBus byte 0 bit 3. These two inputs are logically ANDed. If either the external pin or the internal SMBus register bit is set low then the stoppable PCI clocks will be stopped in a logic low state. Reading SMBus Byte 0 Bit 3 will return a 0 value if either of these control bits are set LOW thereby indicating the device's stoppable PCI clocks are not running.

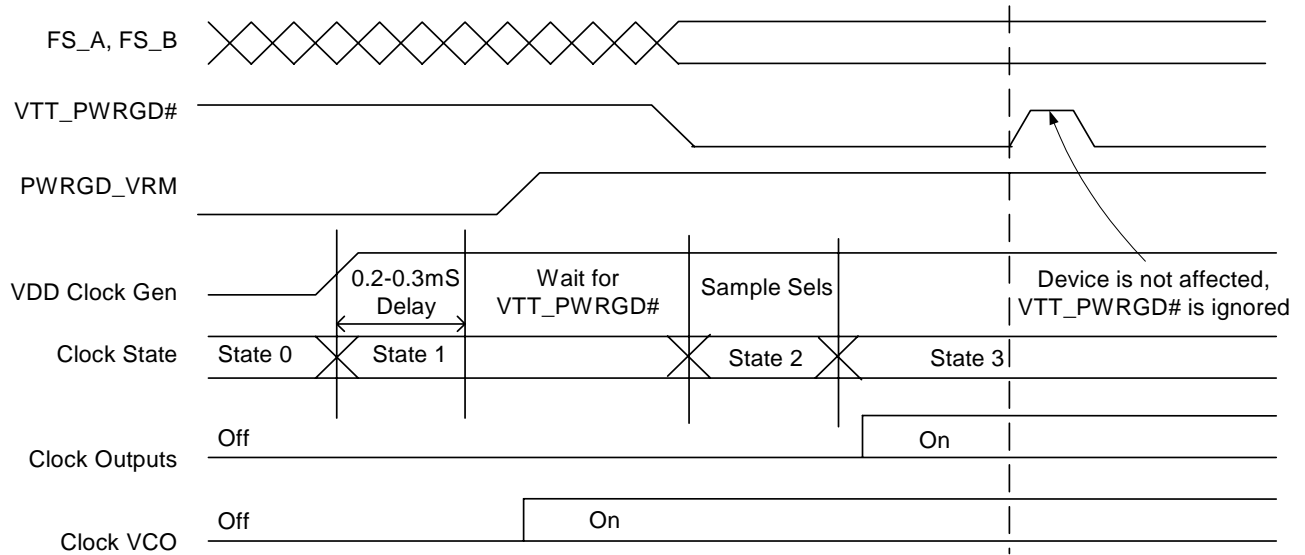


Figure 9. VTT\_PWRGD# Timing Diagram

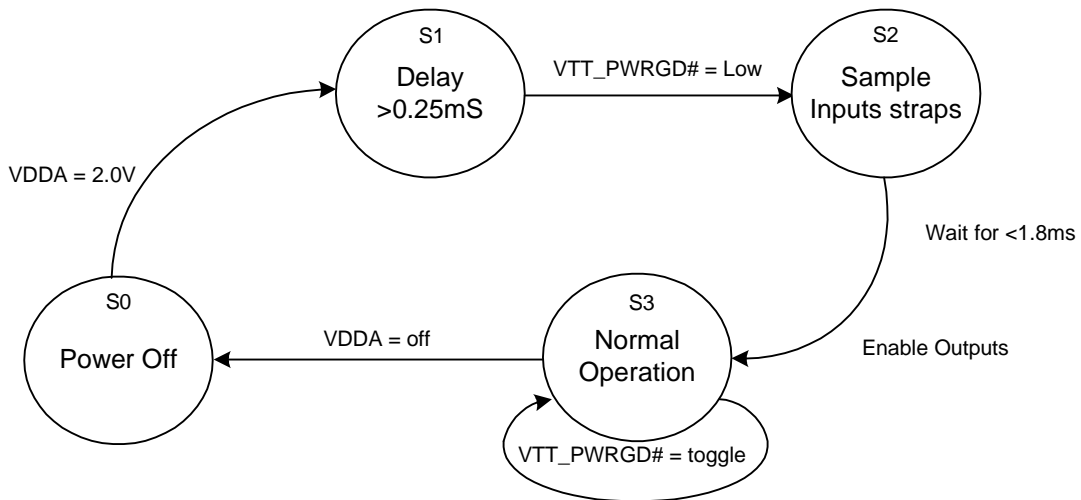


Figure 10. Clock Generator Power-up/Run State Diagram

**Absolute Maximum Conditions**

Parameter	Description	Condition	Min.	Max.	Unit
V <sub>DD</sub>	Core Supply Voltage		-0.5	4.6	V
V <sub>DD_A</sub>	Analog Supply Voltage		-0.5	4.6	V
V <sub>IN</sub>	Input Voltage	Relative to V <sub>SS</sub>	-0.5	V <sub>DD</sub> + 0.5	VDC
T <sub>S</sub>	Temperature, Storage	Non-functional	-65	150	°C
T <sub>A</sub>	Temperature, Operating Ambient	Functional	0	70	°C
T <sub>J</sub>	Temperature, Junction	Functional	-	150	°C
∅ <sub>JC</sub>	Dissipation, Junction to Case	Mil-Spec 883E Method 1012.1	-	15	°C/W
∅ <sub>JA</sub>	Dissipation, Junction to Ambient	JEDEC (JESD 51)	-	45	°C/W
ESD <sub>HBM</sub>	ESD Protection (Human Body Model)	MIL-STD-883, Method 3015	2000	-	V
UL-94	Flammability Rating	@ 1/8 in.		V-0	
MSL	Moisture Sensitivity Level			1	

**Multiple Supplies:** The Voltage on any input or I/O pin cannot exceed the power pin during power-up. Power supply sequencing is NOT required.

**DC Electrical Specifications**

Parameter	Description	Condition	Min.	Max.	Unit
V <sub>DD_A</sub> , V <sub>DD_REF</sub> , V <sub>DD_PCI</sub> , V <sub>DD_3V66</sub> , V <sub>DD_48</sub> , V <sub>DD_CPU</sub>	3.3V Operating Voltage	3.3 ± 5%	3.135	3.465	V
V <sub>IL12C</sub>	Input Low Voltage	SDATA, SCLK	-	1.0	V
V <sub>IH12C</sub>	Input High Voltage	SDATA, SCLK	2.2	-	V
V <sub>IL</sub>	Input Low Voltage		V <sub>SS</sub> - 0.5	0.8	V
V <sub>IH</sub>	Input High Voltage		2.0	V <sub>DD</sub> + 0.5	V
I <sub>IL</sub>	Input Low Leakage Current	except internal pull-ups resistors, 0 < V <sub>IN</sub> < V <sub>DD</sub>	-5		μA
I <sub>IH</sub>	Input High Leakage Current	except internal pull-down resistors, 0 < V <sub>IN</sub> < V <sub>DD</sub>		5	μA
V <sub>OL</sub>	Output Low Voltage	I <sub>OL</sub> = 1 mA	-	0.4	V
V <sub>OH</sub>	Output High Voltage	I <sub>OH</sub> = -1 mA	2.4	-	V
I <sub>OZ</sub>	High-impedance Output Current		-10	10	μA
I <sub>DD</sub>	Dynamic Supply Current	All outputs loaded per Table 9 and Figure 11	-	350	mA
C <sub>IN</sub>	Input Pin Capacitance		2	5	pF
C <sub>OUT</sub>	Output Pin Capacitance		3	6	pF
L <sub>IN</sub>	Pin Inductance		-	7	nH
V <sub>XIH</sub>	Xin High Voltage		0.7V <sub>DD</sub>	V <sub>DD</sub>	V
V <sub>XIL</sub>	Xin Low Voltage		0	0.3V <sub>DD</sub>	V
I <sub>PD3.3V</sub>	Power-down Supply Current	PD# Asserted	-	1	mA

**AC Electrical Specifications**

Parameter	Description	Condition	Min.	Max.	Unit
<b>Crystal</b>					
T <sub>DC</sub>	XIN Duty Cycle	The device will operate reliably with input duty cycles up to 30/70 but the REF clock duty cycle will not be within specification	47.5	52.5	%
T <sub>PERIOD</sub>	XIN Period	When XIN is driven from an external clock source	69.841	71.0	ns
T <sub>R</sub> / T <sub>F</sub>	XIN Rise and Fall Times	Measured between 0.3V <sub>DD</sub> and 0.7V <sub>DD</sub>	–	10.0	ns
T <sub>CCJ</sub>	XIN Cycle to Cycle Jitter	As an average over 1-μs duration	–	500	ps
L <sub>ACC</sub>	Long-term Accuracy	Over 150 ms		300	ppm
<b>CPU at 0.7V</b>					
T <sub>DC</sub>	CPUT and CPUC Duty Cycle	Measured at crossing point V <sub>OX</sub>	45	55	%
T <sub>PERIOD</sub>	100-MHz CPUT and CPUC Period	Measured at crossing point V <sub>OX</sub>	9.9970	10.003	ns
T <sub>PERIOD</sub>	133-MHz CPUT and CPUC Period	Measured at crossing point V <sub>OX</sub>	7.4978	7.5023	ns
T <sub>PERIOD</sub>	200-MHz CPUT and CPUC Period	Measured at crossing point V <sub>OX</sub>	4.9985	5.0015	ns
T <sub>SKEW</sub>	Any CPUT/C to CPUT/C Clock Skew	Measured at crossing point V <sub>OX</sub>	–	100	ps
T <sub>CCJ</sub>	CPUT/C Cycle to Cycle Jitter	Measured at crossing point V <sub>OX</sub>	–	125	ps
T <sub>R</sub> / T <sub>F</sub>	CPUT and CPUC Rise and Fall Times	Measured from V <sub>OL</sub> = 0.175 to V <sub>OH</sub> = 0.525V	175	700	ps
T <sub>RFM</sub>	Rise/Fall Matching	Determined as a fraction of $2*(T_R - T_F)/(T_R + T_F)$	–	20	%
ΔT <sub>R</sub>	Rise Time Variation		–	125	ps
ΔT <sub>F</sub>	Fall Time Variation		–	125	ps
V <sub>HIGH</sub>	Voltage High	Math averages <i>Figure 11</i>	660	850	mv
V <sub>LOW</sub>	Voltage Low	Math averages <i>Figure 11</i>	–150	–	mv
V <sub>OX</sub>	Crossing Point Voltage at 0.7V Swing		250	550	mv
V <sub>OVS</sub>	Maximum Overshoot Voltage		–	V <sub>HIGH</sub> +0.3	V
V <sub>UDS</sub>	Minimum Undershoot Voltage		–0.3	–	V
V <sub>RB</sub>	Ring Back Voltage	See <i>Figure 11</i> . Measure SE	–	0.2	V
<b>SRC</b>					
T <sub>DC</sub>	SRCT and SRCC Duty Cycle	Measured at crossing point V <sub>OX</sub>	45	55	%
T <sub>PERIOD</sub>	100 MHz SRCT and SRCC Period	Measured at crossing point V <sub>OX</sub>	9.9970	10.003	ns
T <sub>PERIOD</sub>	200 MHz SRCT and SRCC Period	Measured at crossing point V <sub>OX</sub>	4.9985	5.0015	ns
T <sub>CCJ</sub>	SRCT/C Cycle to Cycle Jitter	Measured at crossing point V <sub>OX</sub>	–	125	ps
L <sub>ACC</sub>	SRCT/C Long Term Accuracy	Measured at crossing point V <sub>OX</sub>	–	300	ppm
T <sub>R</sub> / T <sub>F</sub>	SRCT and SRCC Rise and Fall Times	Measured from V <sub>OL</sub> = 0.175 to V <sub>OH</sub> = 0.525V	175	700	ps
T <sub>RFM</sub>	Rise/Fall Matching	Determined as a fraction of $2*(T_R - T_F)/(T_R + T_F)$	–	20	%
ΔT <sub>R</sub>	Rise Time Variation		–	125	ps
ΔT <sub>F</sub>	Fall Time Variation		–	125	ps
V <sub>HIGH</sub>	Voltage High	Math averages <i>Figure 11</i>	660	850	mv
V <sub>LOW</sub>	Voltage Low	Math averages <i>Figure 11</i>	–150	–	mv
V <sub>OX</sub>	Crossing Point Voltage at 0.7V Swing		250	550	mV
V <sub>OVS</sub>	Maximum Overshoot Voltage		–	V <sub>HIGH</sub> +0.3	V
V <sub>UDS</sub>	Minimum Undershoot Voltage		–0.3	–	V
V <sub>RB</sub>	Ring Back Voltage	See <i>Figure 11</i> . Measure SE	–	0.2	V
<b>3V66</b>					
T <sub>DC</sub>	3V66 Duty Cycle	Measurement at 1.5V	45	55	%
T <sub>PERIOD</sub>	Spread Disabled 3V66 Period	Measurement at 1.5V	14.9955	15.0045	ns
T <sub>PERIOD</sub>	Spread Enabled 3V66 Period	Measurement at 1.5V	14.9955	15.0799	ns
T <sub>HIGH</sub>	3V66 High Time	Measurement at 2.0V	4.9500	–	ns
T <sub>LOW</sub>	3V66 Low Time	Measurement at 0.8V	4.5500	–	ns

**AC Electrical Specifications** (continued)

Parameter	Description	Condition	Min.	Max.	Unit
T <sub>R</sub> / T <sub>F</sub>	3V66 Rise and Fall Times	Measured between 0.8V and 2.0V	0.5	2.0	ns
T <sub>SKEW</sub>	Any 3V66 to Any 3V66 Clock Skew	Measurement at 1.5V	–	250	ps
T <sub>CCJ</sub>	3V66 Cycle to Cycle Jitter	Measurement at 1.5V	–	250	ps
<b>PCI/PCIF</b>					
T <sub>DC</sub>	PCI Duty Cycle	Measurement at 1.5V	45	55	%
T <sub>PERIOD</sub>	Spread Disabled PCIF/PCI Period	Measurement at 1.5V	29.9910	30.0009	ns
T <sub>PERIOD</sub>	Spread Enabled PCIF/PCI Period	Measurement at 1.5V	29.9910	30.1598	ns
T <sub>HIGH</sub>	PCIF and PCI high time	Measurement at 2.0V	12.0	–	ns
T <sub>LOW</sub>	PCIF and PCI low time	Measurement at 0.8V	12.0	–	ns
T <sub>R</sub> / T <sub>F</sub>	PCIF and PCI rise and fall times	Measured between 0.8V and 2.0V	0.5	2.0	ns
T <sub>SKEW</sub>	Any PCI clock to Any PCI clock Skew	Measurement at 1.5V	–	500	ps
T <sub>CCJ</sub>	PCIF and PCI Cycle to Cycle Jitter	Measurement at 1.5V	–	250	ps
<b>DOT</b>					
T <sub>DC</sub>	Duty Cycle	Measurement at 1.5V	45	55	%
T <sub>PERIOD</sub>	Period	Measurement at 1.5V	20.8271	20.8396	ns
T <sub>SKEW</sub>	Any 48-MHz to 48-MHz Clock Skew	Measured at crossing point V <sub>OX</sub>	–	500	ps
T <sub>HIGH</sub>	USB high time	Measurement at 2.0V	8.994	10.486	ns
T <sub>LOW</sub>	USB low time	Measurement at 0.8V	8.794	10.386	ns
T <sub>R</sub> / T <sub>F</sub>	Rise and Fall Times	Measured between 0.8V and 2.0V	0.5	1.0	ns
T <sub>CCJ</sub>	Cycle to Cycle Jitter	Measurement at 1.5V	–	350	ps
<b>USB</b>					
T <sub>DC</sub>	Duty Cycle	Measurement at 1.5V	45	55	%
T <sub>PERIOD</sub>	Period	Measurement at 1.5V	20.8271	20.8396	ns
T <sub>SKEW</sub>	Any 48-MHz to 48-MHz Clock Skew	Measured at crossing point V <sub>OX</sub>	–	500	ps
T <sub>HIGH</sub>	USB high time	Measurement at 2.0V	8.094	10.036	ns
T <sub>LOW</sub>	USB low time	Measurement at 0.8V	7.694	9.836	ns
T <sub>R</sub> / T <sub>F</sub>	Rise and Fall Times	Measured between 0.8V and 2.0V	1.0	2.0	ns
T <sub>CCJ</sub>	Cycle to Cycle Jitter	Measurement at 1.5V	–	350	ps
<b>REF</b>					
T <sub>DC</sub>	REF Duty Cycle	Measurement at 1.5V	45	55	%
T <sub>PERIOD</sub>	REF Period	Measurement at 1.5V	69.827	69.855	ns
T <sub>SKEW</sub>	Any REF to REF Clock Skew	Measured at crossing point V <sub>OX</sub>	–	500	ps
T <sub>R</sub> / T <sub>F</sub>	REF Rise and Fall Times	Measured between 0.8V and 2.0V	0.5	2.0	ns
T <sub>CCJ</sub>	REF Cycle to Cycle Jitter	Measurement at 1.5V	–	1000	ps
<b>ENABLE/DISABLE and SET-UP</b>					
T <sub>STABLE</sub>	Clock Stabilization from Power-up		–	1.8	ms
T <sub>SS</sub>	Stopclock Set-up Time		10.0	–	ns
T <sub>SH</sub>	Stopclock Hold Time		0	–	ns

**Table 7. Group Timing Relationship and Tolerances**

Group	Conditions	Offset	
		Min.	Max.
3V66 to PCI	3V66 Leads PCI	1.5 ns	3.5 ns

**Table 8. USB to DOT Phase Offset**

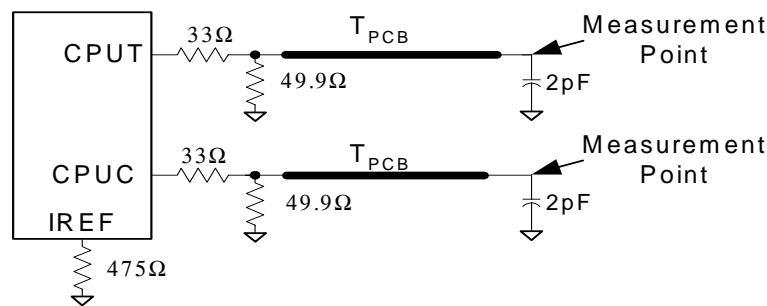
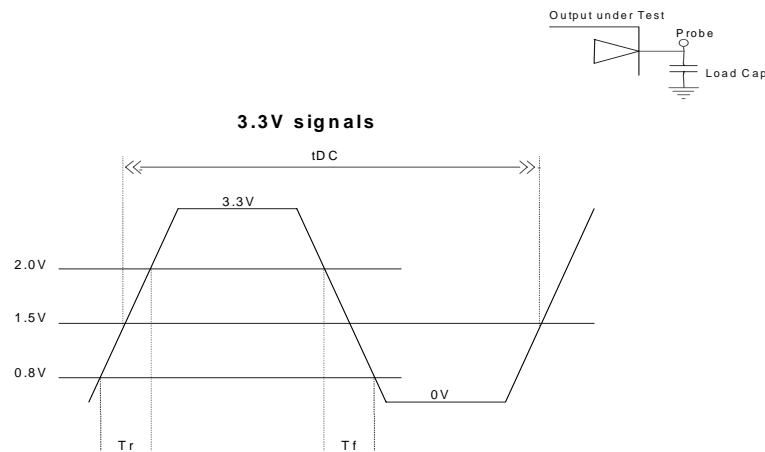
Parameter	Typical	Value	Tolerance
DOT Skew	0°	0.0 ns	1000 ps
USB Skew	180°	0.0 ns	1000 ps
VCH Skew	0°	0.0 ns	1000 ps

**Table 9. Maximum Lumped Capacitive Output Loads**

Clock	Max Load	Unit
PCI Clocks	30	pF
3V66 Clocks	30	pF
USB Clock	20	pF
DOT Clock	10	pF
REF Clock	30	pF

**Test and Measurement Set-up**
**For Differential CPU and SRC Output Signals**

The following diagram shows lumped test load configurations for the differential Host Clock Outputs.


**Figure 11. 0.7V Load Configuration**

**Figure 12. Lumped Load For Single-ended Output Signals (for AC Parameters Measurement)**
**Table 10. CPU Clock Current Select Function**

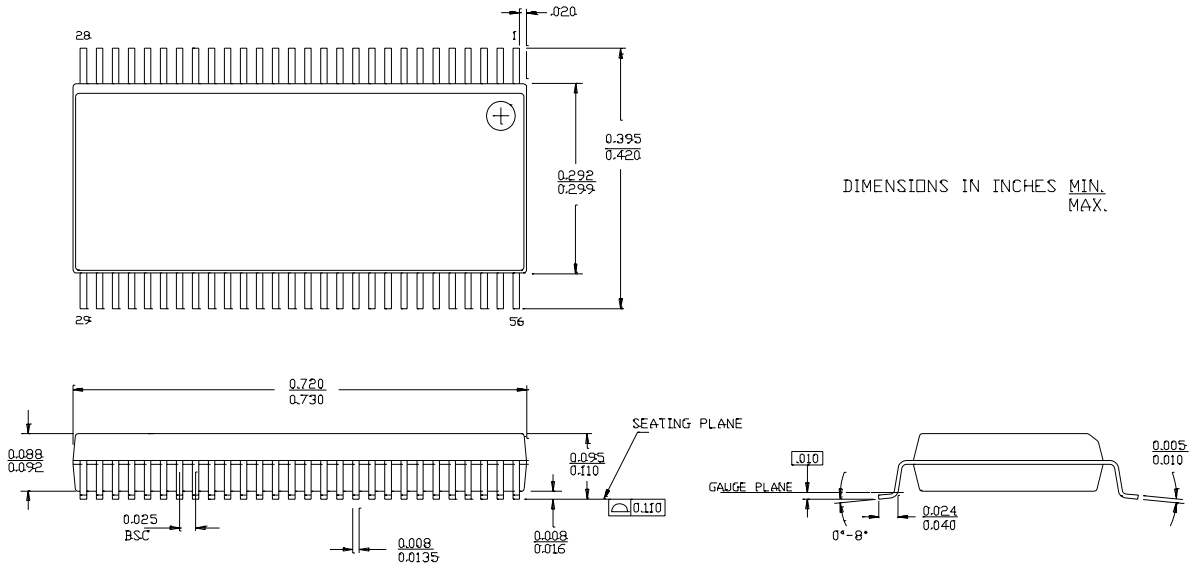
Board Target Trace/Term Z	Reference R, $I_{REF} - V_{DD} (3 \cdot R_{REF})$	Output Current	Voh @ Z
50 Ohms	$R_{REF} = 475 \text{ } \Omega$ , $I_{REF} = 2.32 \text{ mA}$	$I_{OH} = 6 \cdot I_{REF}$	0.7V @ 50

**Ordering Information**

Part Number	Package Type	Product Flow
CY28409OC	56-pin SSOP	Commercial, 0° to 70°C
CY28409OCT	56-pin SSOP – Tape and Reel	Commercial, 0° to 70°C
CY28409ZC	56-pin TSSOP	Commercial, 0° to 70°C
CY28409ZCT	56-pin TSSOP – Tape and Reel	Commercial, 0° to 70°C

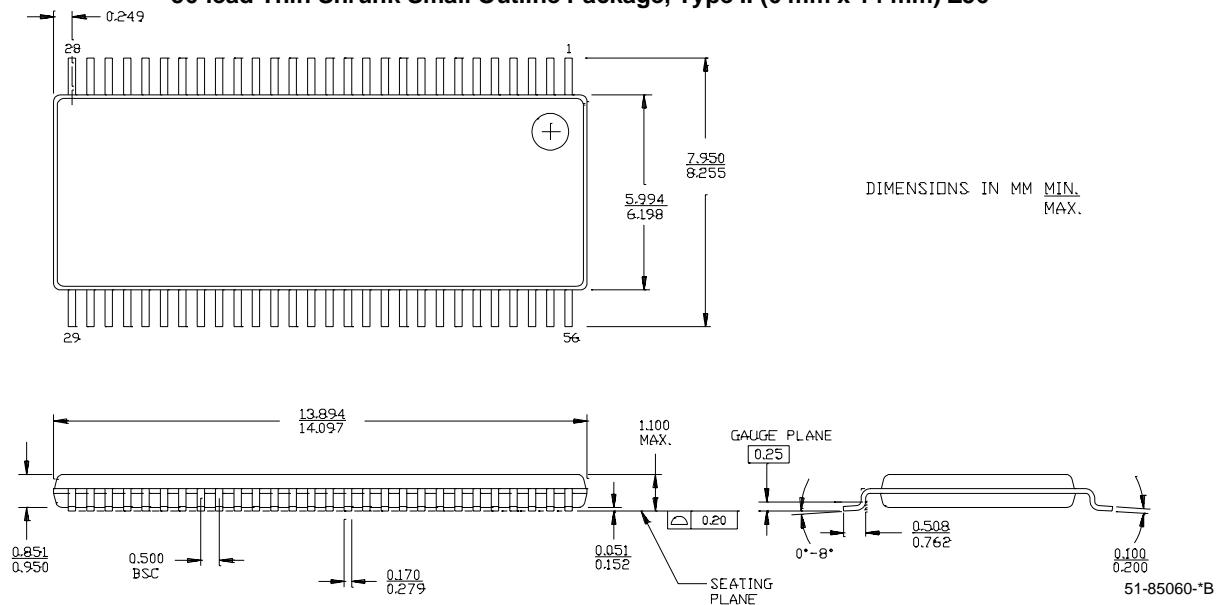
Package Drawings and Dimensions

56-lead Shrunken Small Outline Package O56



51-85062-C

56-lead Thin Shrunken Small Outline Package, Type II (6 mm x 14 mm) Z56



51-85060-B

Purchase of I<sup>2</sup>C components from Cypress or one of its sublicensed Associated Companies conveys a license under the Philips I<sup>2</sup>C Patent Rights to use these components in an I<sup>2</sup>C system, provided that the system conforms to the I<sup>2</sup>C Standard Specification as defined by Philips. Intel and Pentium are registered trademarks of Intel Corporation. All product and company names mentioned in this document are the trademarks of their respective holders.

**Document History Page**

<b>Document Title: CY28409 Clock Synthesizer with Differential SRC and CPU Outputs</b>				
<b>Document Number: 38-07445</b>				
<b>REV.</b>	<b>ECN NO.</b>	<b>Issue Date</b>	<b>Orig. of Change</b>	<b>Description of Change</b>
**	121414	12/04/02	RGL	New Data Sheet
*A	124795	07/07/03	RGL	Changed revision code to 4 Corrected rise/fall time value on DOT from 1.0/2.0 to 0.5/1.0 ns, respectively Changed USB and DOT from long-term jitter to cycle-to-cycle jitter Changed USB and DOT period value from 28.8257/28.8340 to 20.8271/20.8396 ns, respectively
*B	128864	08/29/03	RGL	Fixed the I <sup>2</sup> C registers to match the actual device Removed all items referencing to 166 MHz



LittleDiode supplies new, hard to find or obsolete electronic components and semiconductors all over the world.

With over two million different components listed you are sure to find the part you need.

Feel free to visit us today at our online store:

[LittleDiode.com](http://LittleDiode.com)

Looking forward to providing you with the best possible service.