

2-Mbit (128K x 16) Static RAM

Features

- **Temperature Ranges**
 - Commercial: 0°C to 70°C
 - Industrial: -40°C to 85°C
 - Automotive: -40°C to 125°C
- **High Speed: 55 ns and 70 ns**
- **Wide voltage range: 2.7V–3.6V**
- **Ultra-low active, standby power**
- **Easy memory expansion with CE and OE features**
- **TTL-compatible inputs and outputs**
- **Automatic power-down when deselected**
- **CMOS for optimum speed/power**
- **Package Available in a standard 44-pin TSOP Type II (forward pinout) package**

Functional Description^[1]

The CY62137V is a high-performance CMOS static RAM organized as 128K words by 16 bits. This device features advanced circuit design to provide ultra-low active current. This is ideal for providing More Battery Life[®] (MoBL[®]) in portable applications such as cellular telephones. The device

also has an automatic power-down feature that reduces power consumption by 99% when addresses are not toggling. The device can also be put into standby mode when deselected (CE HIGH) or when CE is LOW and both BLE and BHE are HIGH. The input/output pins (I/O₀ through I/O₁₅) are placed in a high-impedance state when: deselected (CE HIGH), outputs are disabled (OE HIGH), BHE and BLE are disabled (BHE, BLE HIGH), or during a write operation (CE LOW, and WE LOW).

Writing to the device is accomplished by taking Chip Enable (CE) and Write Enable (WE) inputs LOW. If Byte Low Enable (BLE) is LOW, then data from I/O pins (I/O₀ through I/O₇), is written into the location specified on the address pins (A₀ through A₁₆). If Byte High Enable (BHE) is LOW, then data from I/O pins (I/O₈ through I/O₁₅) is written into the location specified on the address pins (A₀ through A₁₆).

Reading from the device is accomplished by taking Chip Enable (CE) and Output Enable (OE) LOW while forcing the Write Enable (WE) HIGH. If Byte Low Enable (BLE) is LOW, then data from the memory location specified by the address pins will appear on I/O₀ to I/O₇. If Byte High Enable (BHE) is LOW, then data from memory will appear on I/O₈ to I/O₁₅. See the truth table at the back of this data sheet for a complete description of read and write modes.

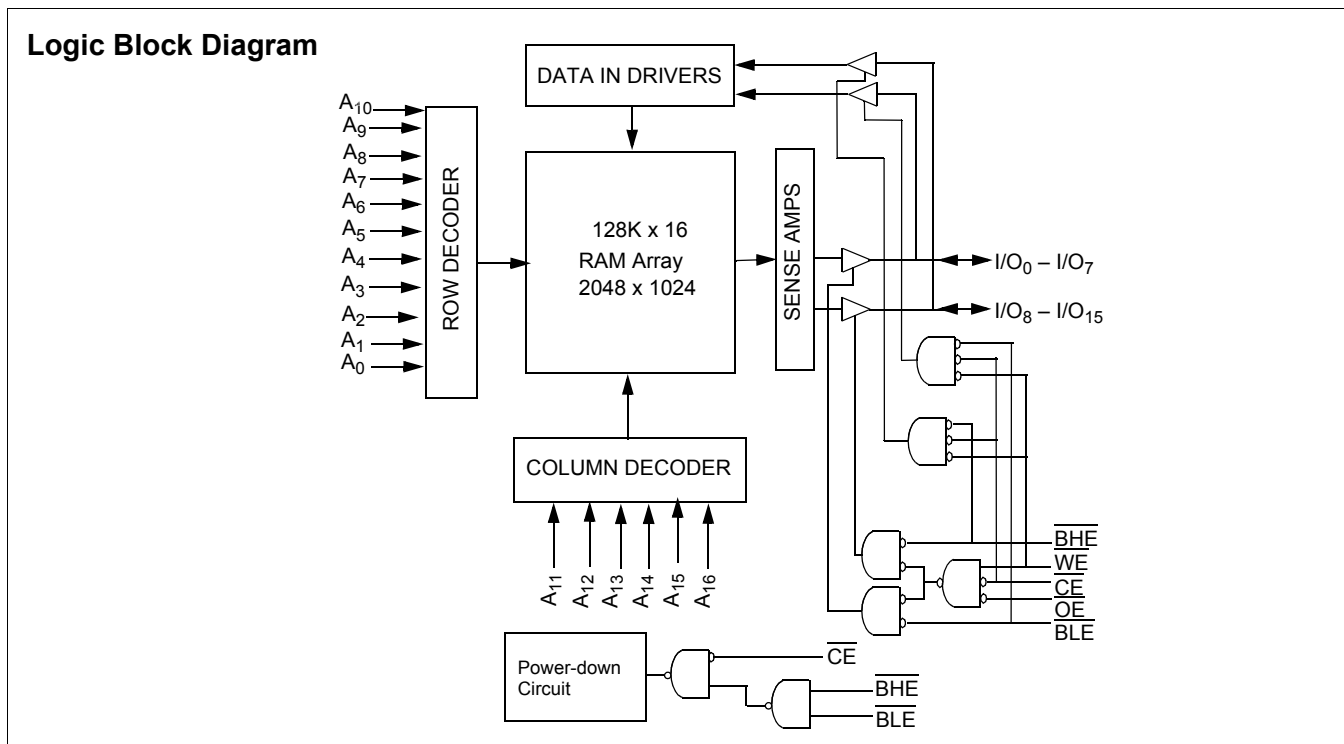

Note:

1. For best practice recommendations, please refer to the Cypress application note "System Design Guidelines" on <http://www.cypress.com>.

Product Portfolio

Product		V _{CC} Range (V)			Speed (ns)	Power Dissipation			
						Operating, I _{CC} (mA)		Standby, I _{SB2} (μA)	
		Min.	Typ. ^[3]	Max.		Typ. ^[3]	Max.	Typ. ^[3]	Max.
CY62137VLL	Industrial	2.7	3.0	3.6	55	7	20	1	15
CY62137VSL					55	7	20	1	5
CY62137VLL					70	7	15	1	15
CY62137VSL					70	7	15	1	5
CY62137VLL	Automotive				70	7	15	1	20

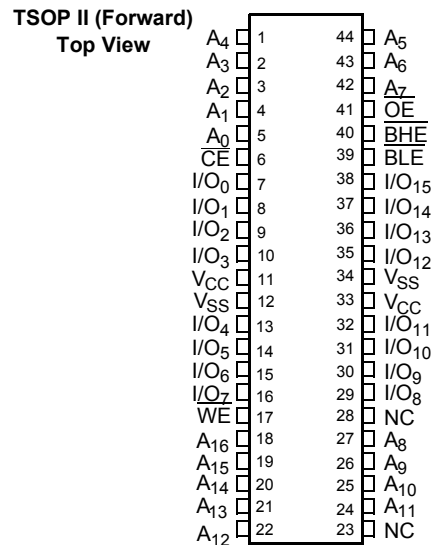
Pin Configurations

Pin Definitions

Pin Number	Type	Description
1-5, 18-22, 24-27, 42-45	Input	A ₀ -A ₁₆ . Address Inputs
7-10, 13-16, 29-32, 35-38	Input/Output	I/O ₀ -I/O ₁₅ . Data lines. Used as input or output lines depending on operation
23	No Connect	NC. This pin is not connected to the die
17	Input/Control	WE. When selected LOW, a WRITE is conducted. When selected HIGH, a READ is conducted
6	Input/Control	CE. When LOW, selects the chip. When HIGH, deselects the chip
39, 40	Input/Control	BHE, BLE. BHE = LOW selects higher order byte WRITES or READs on the SRAM. BLE = LOW selects lower order byte WRITES or READs on the SRAM
41	Input/Control	OE. Output Enable. Controls the direction of the I/O pins. When LOW, the I/O pins behave as outputs. When deasserted HIGH, I/O pins are three-stated, and act as input data pins
12, 34	Ground	V _{SS} . Ground for the device
11, 33	Power Supply	V _{CC} . Power supply for the device

Notes:

- NC pins are not connected on the die.
- Typical values are included for reference only and are not guaranteed or tested. Typical values are measured at V_{CC} = V_{CC(TYP)}, T_A = 25°C.

Maximum Ratings

(Above which the useful life may be impaired. For user guidelines, not tested.)

Storage Temperature	-65°C to +150°C
Ambient Temperature with Power Applied.....	-55°C to +125°C
Supply Voltage to Ground Potential	-0.5V to +4.6V
DC Voltage Applied to Outputs in High-Z State ^[4]	-0.5V to $V_{CC} + 0.5V$
DC Input Voltage ^[4]	-0.5V to $V_{CC} + 0.5V$

Output Current into Outputs (LOW).....	20 mA
Static Discharge Voltage.....	> 2001V (per MIL-STD-883, Method 3015)
Latch-up Current.....	> 200 mA

Operating Range

Range	Ambient Temperature	V_{CC}
Industrial	-40°C to +85°C	2.7V to 3.6V
Automotive	-40°C to +125°C	2.7V to 3.6V

Electrical Characteristics Over the Operating Range

Parameter	Description	Test Conditions	CY62137V-55			CY62137V-70			Unit
			Min.	Typ. ^[3]	Max.	Min.	Typ. ^[3]	Max.	
V_{OH}	Output HIGH Voltage	$I_{OH} = -1.0 \text{ mA}$ $V_{CC} = 2.7V$	2.4			2.4			V
V_{OL}	Output LOW Voltage	$I_{OL} = 2.1 \text{ mA}$ $V_{CC} = 2.7V$			0.4			0.4	V
V_{IH}	Input HIGH Voltage		2.2		$V_{CC} + 0.5V$	2.2		$V_{CC} + 0.5V$	V
V_{IL}	Input LOW Voltage		-0.5		0.8	-0.5		0.8	V
I_{IX}	Input Load Current	$GND \leq V_I \leq V_{CC}$	-1		+1	-1		+1	μA
I_{OZ}	Output Leakage Current	$GND \leq V_O \leq V_{CC}$, Output Disabled	-1		+1	-1		+1	μA
I_{CC}	V_{CC} Operating Supply Current	$I_{OUT} = 0 \text{ mA}$, $f = f_{MAX} = 1/t_{RC}$, CMOS Levels		7	20		7	15	mA
		$I_{OUT} = 0 \text{ mA}$, $f = 1 \text{ MHz}$, CMOS Levels		1	2		1	2	mA
I_{SB1}	Automatic CE Power-down Current— CMOS Inputs	$CE \geq V_{CC} - 0.3V$, $V_{IN} \geq V_{CC} - 0.3V$ or $V_{IN} \leq 0.3V$, $f = f_{MAX}$			100			100	μA
I_{SB2}	Automatic CE Power-down Current— CMOS Inputs	$CE \geq V_{CC} - 0.3V$, $V_{IN} \geq V_{CC} - 0.3V$ or $V_{IN} \leq 0.3V$, $f = 0$	$V_{CC} = 3.6V$	LL	1	15	1	15	
				Automotive			1	20	
				SL	1	5	1	5	

Capacitance^[5]

Parameter	Description	Test Conditions	Max.	Unit
C_{IN}	Input Capacitance	$T_A = 25^\circ\text{C}$, $f = 1 \text{ MHz}$, $V_{CC} = V_{CC}(\text{typ})$	6	pF
C_{OUT}	Output Capacitance		8	pF

Thermal Resistance

Description	Test Conditions	Symbol	TSOPII	Unit
Thermal Resistance (Junction to Ambient) ^[5]	Still Air, soldered on a 4.25 x 1.125 inch, 4-layer printed circuit board	Θ_{JA}	60	$^\circ\text{C/W}$
Thermal Resistance (Junction to Case) ^[5]		Θ_{JC}	22	$^\circ\text{C/W}$

Notes:

- $V_{IL}(\text{min.}) = -2.0V$ for pulse durations less than 20 ns.
- Tested initially and after any design or process changes that may affect these parameters.

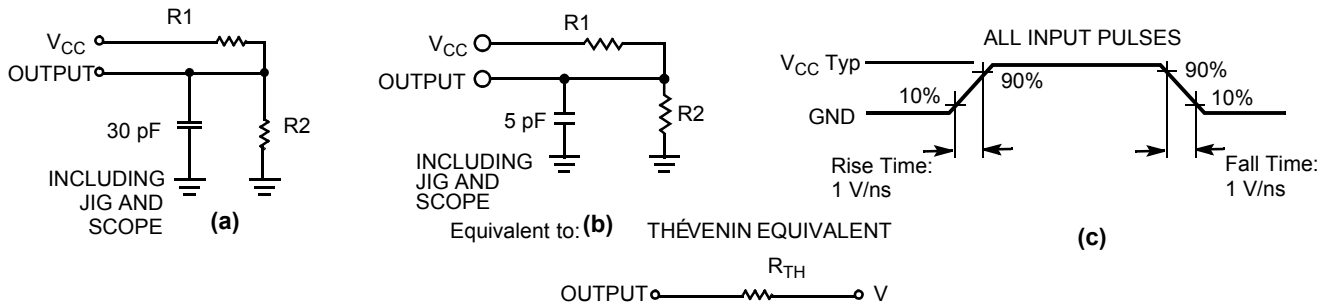
AC Test Loads and Waveforms

Parameters	3.0V	Unit
R1	1105	Ohms
R2	1550	Ohms
R_{TH}	645	Ohms
V_{TH}	1.75	Volts

Data Retention Characteristics (Over the Operating Range)

Parameter	Description	Conditions	Min.	Typ. ^[3]	Max.	Unit
V_{DR}	V_{CC} for Data Retention		1.0			V
I_{CCDR}	Data Retention Current	$V_{CC} = 1.0V$, $\overline{CE} \geq V_{CC} - 0.3V$, $V_{IN} \geq V_{CC} - 0.3V$ or $V_{IN} \leq 0.3V$; No input may exceed; $V_{CC} + 0.3V$		0.5	7.5	μA
		LL				
		Automotive			10	
		SL		0.5	5	
$t_{CDR}^{[5]}$	Chip Deselect to Data Retention Time		0			ns
t_R	Operation Recovery Time		70			ns

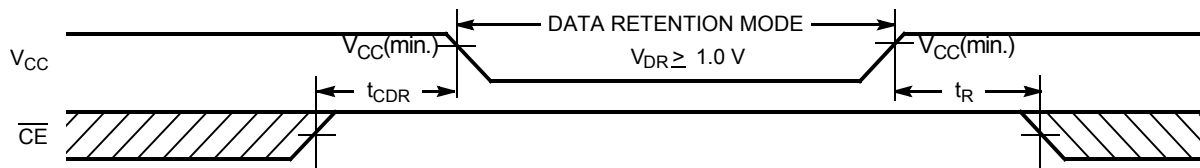
Data Retention Waveform

Switching Characteristics Over the Operating Range ^[6]

Parameter	Description	55 ns		70 ns		Unit
		Min.	Max.	Min.	Max.	
Read Cycle						
t_{RC}	Read Cycle Time	55		70		ns
t_{AA}	Address to Data Valid		55		70	ns
t_{OHA}	Data Hold from Address Change	10		10		ns
t_{ACE}	\overline{CE} LOW to Data Valid		55		70	ns
t_{DOE}	\overline{OE} LOW to Data Valid		25		35	ns
t_{LZOE}	\overline{OE} LOW to Low-Z ^[7]	5		5		ns
t_{HZOE}	\overline{OE} HIGH to High-Z ^[7, 8]		25		25	ns
t_{LZCE}	\overline{CE} LOW to Low-Z ^[7]	10		10		ns
t_{HZCE}	\overline{CE} HIGH to High-Z ^[7, 8]		25		25	ns
t_{PU}	\overline{CE} LOW to Power-up	0		0		ns
t_{PD}	\overline{CE} HIGH to Power-down		55		70	ns
t_{DBE}	\overline{BHE} / \overline{BLE} LOW to Data Valid		55		70	ns
$t_{LZBE}^{(9)}$	\overline{BHE} / \overline{BLE} LOW to Low-Z	5		5		ns
t_{HZBE}	\overline{BHE} / \overline{BLE} HIGH to High-Z		25		25	ns
Write Cycle^[10, 11]						
t_{WC}	Write Cycle Time	55		70		ns
t_{SCE}	\overline{CE} LOW to Write End	45		60		ns
t_{AW}	Address Set-up to Write End	45		60		ns
t_{HA}	Address Hold from Write End	0		0		ns
t_{SA}	Address Set-up to Write Start	0		0		ns
t_{PWE}	\overline{WE} Pulse Width	40		50		ns
t_{SD}	Data Set-up to Write End	25		30		ns
t_{HD}	Data Hold from Write End	0		0		ns
t_{HZWE}	\overline{WE} LOW to High-Z ^[7, 8]		20		25	ns
t_{LZWE}	\overline{WE} HIGH to Low-Z ^[7]	5		10		ns
t_{BW}	\overline{BHE} / \overline{BLE} LOW to End of Write	50		60		ns

Notes:

6. Test conditions assume signal transition time of 5 ns or less, timing reference levels of 1.5V, input levels of 0 to V_{CC} typ., and output loading of the specified I_{OL}/I_{OH} and 30 pF load capacitance.
7. At any given temperature and voltage condition, t_{HZCE} is less than t_{LZCE} , t_{HZOE} is less than t_{LZOE} , and t_{HZWE} is less than t_{LZWE} for any given device.
8. t_{HZOE} , t_{HZCE} , and t_{HZWE} are specified with $C_L = 5$ pF as in (b) of AC Test Loads. Transition is measured ± 500 mV from steady-state voltage.
9. If both byte enables are toggled together this value is 10 ns.
10. The internal write time of the memory is defined by the overlap of \overline{CE} LOW and \overline{WE} LOW. Both signals must be LOW to initiate a write and either signal can terminate a write by going HIGH. The data input set-up and hold timing should be referenced to the rising edge of the signal that terminates the write.
11. The minimum write cycle time for write cycle #3 (WE controlled, OE LOW) is the sum of t_{HZWE} and t_{SD} .

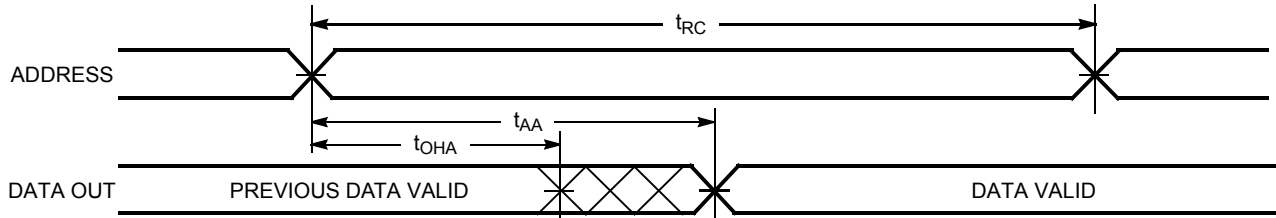
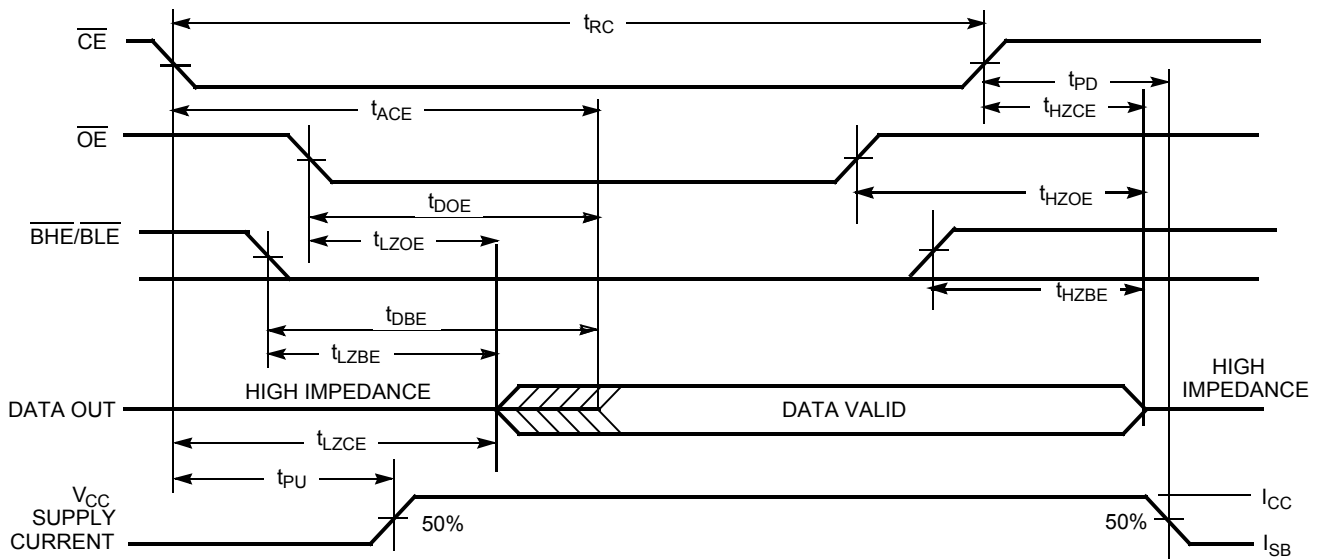
Switching Waveforms
Read Cycle No. 1 ^[12, 13]

Read Cycle No. 2 ^[13, 14]

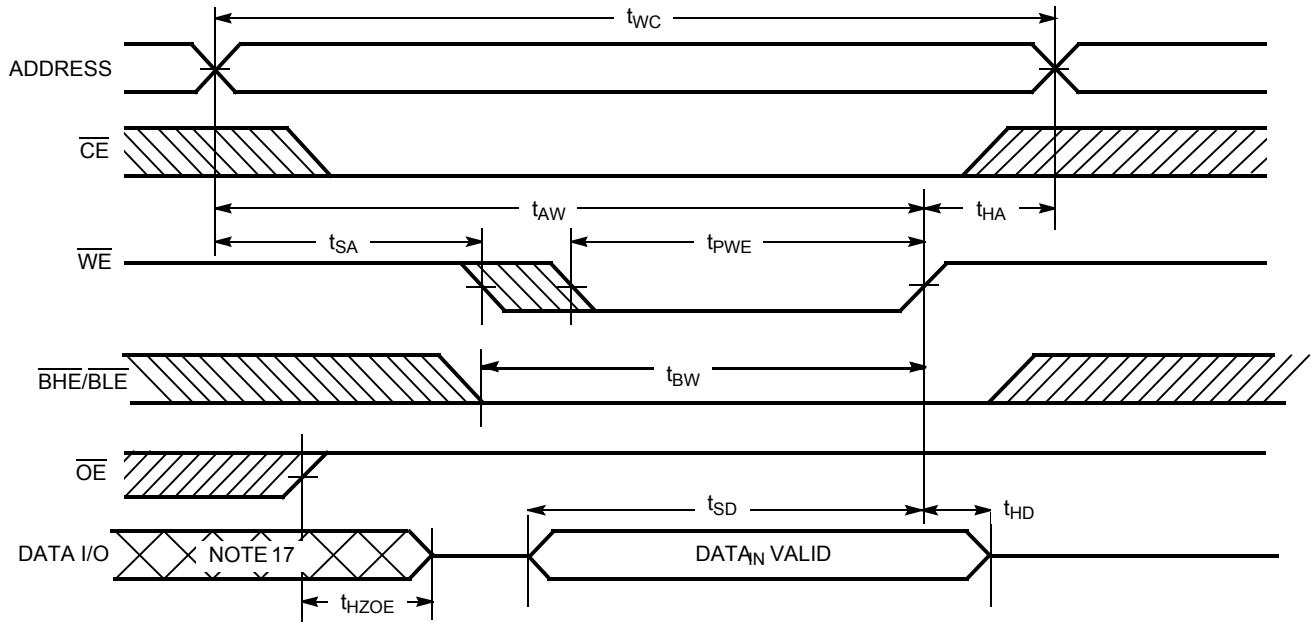
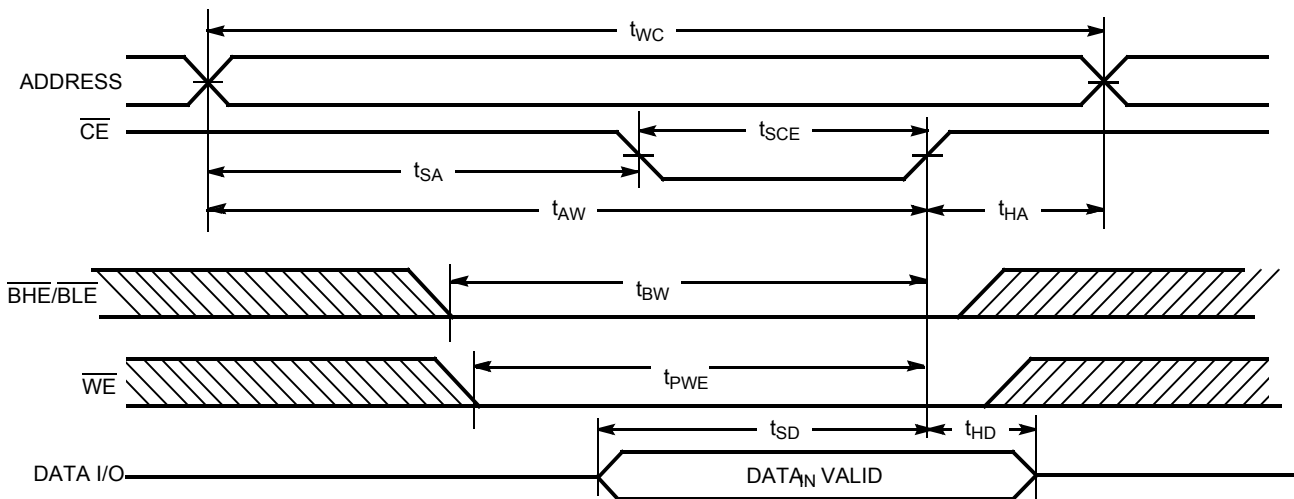
Notes:

12. Device is continuously selected. $\overline{OE}, \overline{CE} = V_{IL}$.
13. \overline{WE} is HIGH for read cycle.
14. Address valid prior to or coincident with \overline{CE} transition LOW.

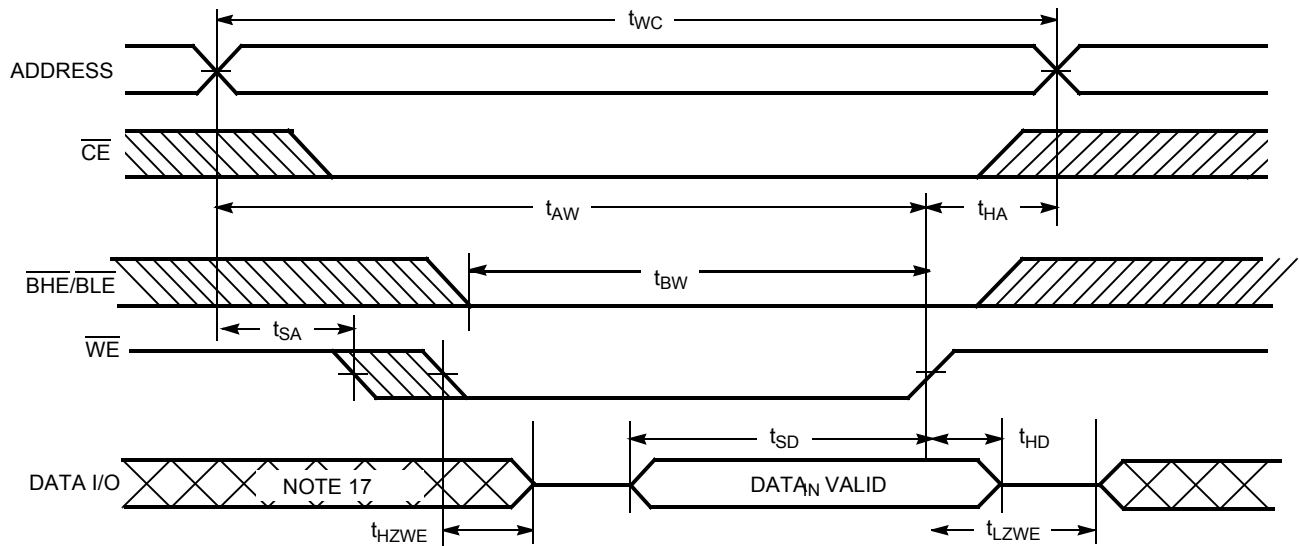
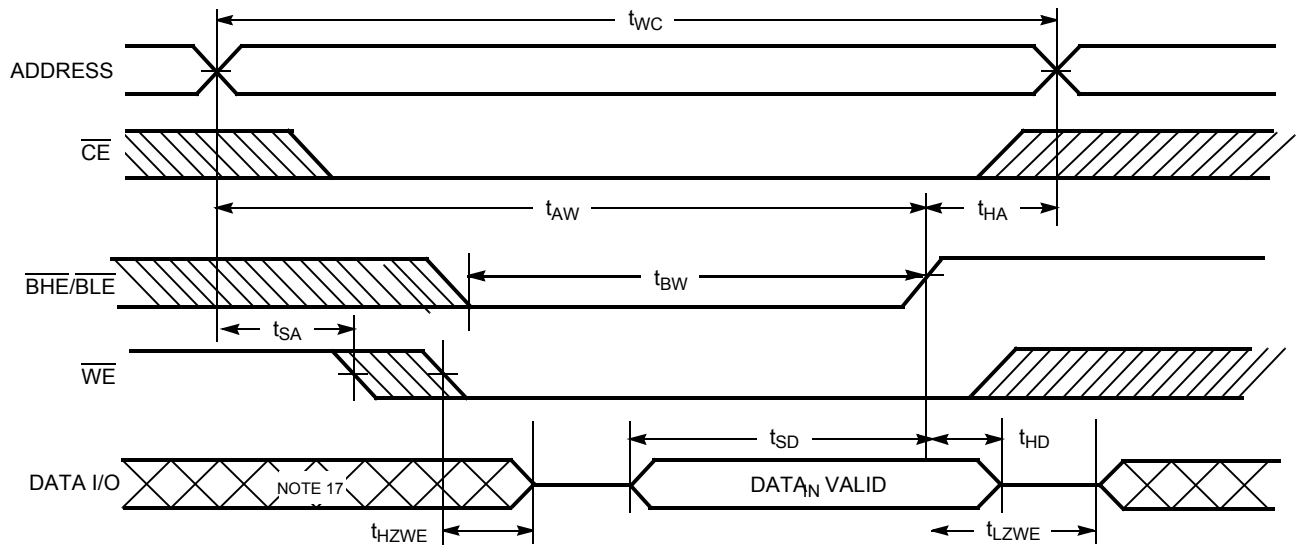
Switching Waveforms (continued)
Write Cycle No. 1 (\overline{WE} Controlled)^[10, 15, 16]

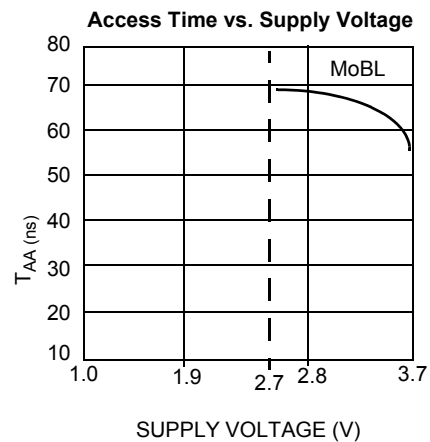
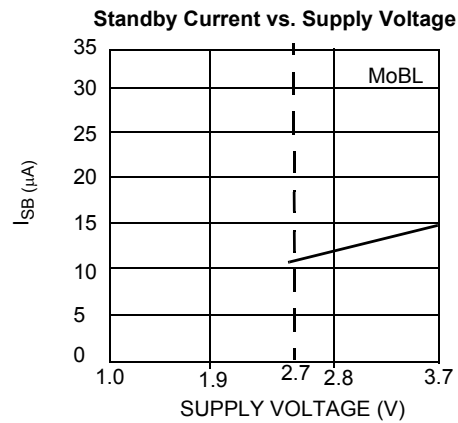
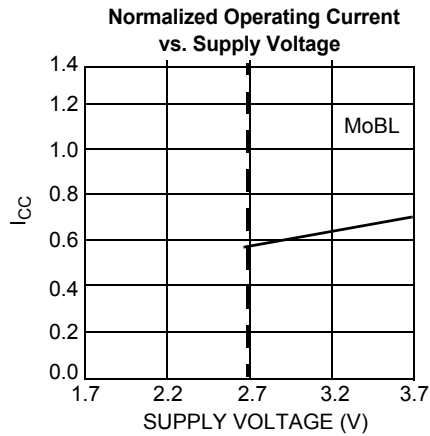
Write Cycle No. 2 (\overline{CE} Controlled)^[10, 15, 16]

Notes:

- 15. Data I/O is high-impedance if $\overline{OE} = V_{IH}$.
- 16. If \overline{CE} goes HIGH simultaneously with \overline{WE} HIGH, the output remains in a high-impedance state.
- 17. During this period, the I/Os are in output state and input signals should not be applied.

Switching Waveforms (continued)
Write Cycle No. 3 ($\overline{\text{WE}}$ Controlled, $\overline{\text{OE}}$ LOW)^[11, 16]

Write Cycle No. 4 ($\overline{\text{BHE/BLE}}$ Controlled, $\overline{\text{OE}}$ LOW)^[17]

Typical DC and AC Characteristics

Truth Table

\overline{CE}	\overline{WE}	\overline{OE}	\overline{BHE}	\overline{BLE}	Inputs/Outputs	Mode	Power
H	X	X	X	X	High-Z	Deselect/Power-down	Standby (I_{SB})
L	X	X	H	H	High-Z	Deselect/Power-down	Standby (I_{SB})
L	H	L	L	L	Data Out (I/O_0 – I/O_{15})	Read	Active (I_{CC})
L	H	L	H	L	Data Out (I/O_0 – I/O_7); I/O_8 – I/O_{15} in High-Z	Read	Active (I_{CC})
L	H	L	L	H	Data Out (I/O_8 – I/O_{15}); I/O_0 – I/O_7 in High-Z	Read	Active (I_{CC})
L	H	H	L	L	High-Z	Deselect/Output Disabled	Active (I_{CC})
L	H	H	H	L	High-Z	Deselect/Output Disabled	Active (I_{CC})
L	H	H	L	H	High-Z	Deselect/Output Disabled	Active (I_{CC})
L	L	X	L	L	Data In (I/O_0 – I/O_{15})	Write	Active (I_{CC})
L	L	X	H	L	Data In (I/O_0 – I/O_7); I/O_8 – I/O_{15} in High-Z	Write	Active (I_{CC})
L	L	X	L	H	Data In (I/O_8 – I/O_{15}); I/O_0 – I/O_7 in High-Z	Write	Active (I_{CC})

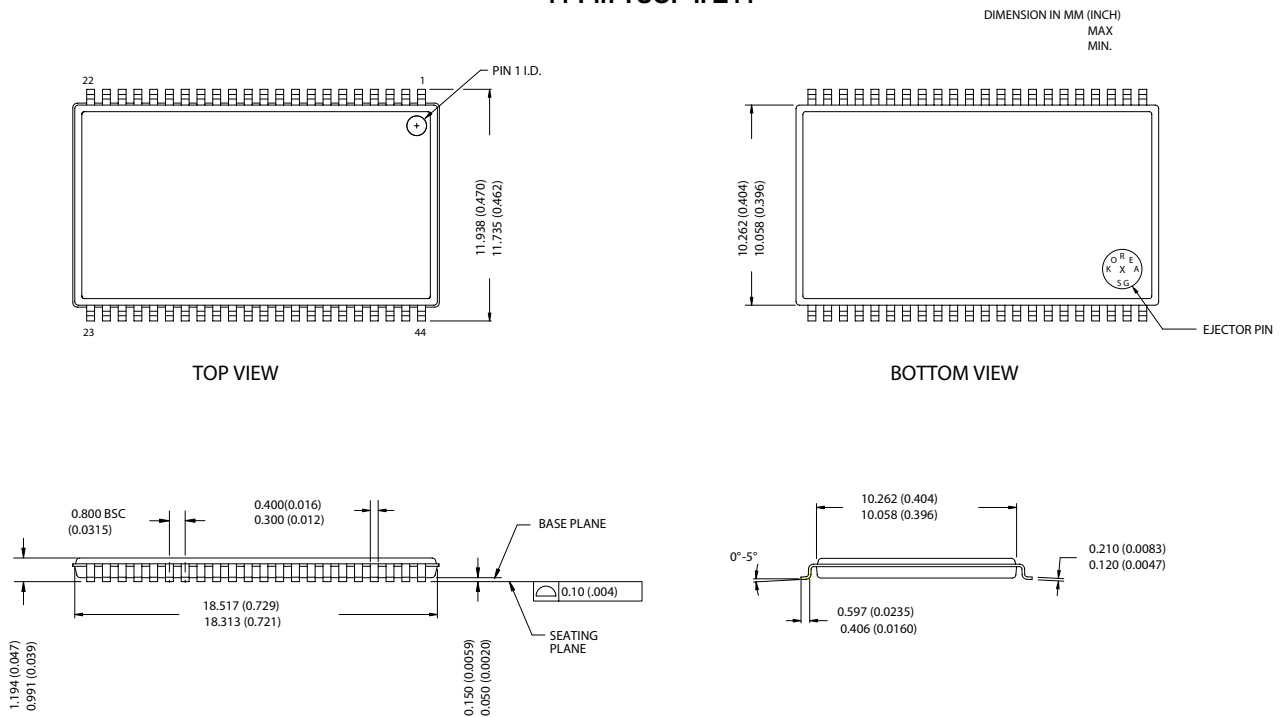
Ordering Information

Speed (ns)	Ordering Code	Package Name	Package Type	Operating Range
55	CY62137VLL-55ZI	Z44	44-pin TSOP II	Industrial
	CY62137VSL-55ZI			
70	CY62137VLL-70ZI			
	CY62137VSL-70ZI			
	CY62137VLL-70ZE			Automotive

Package Diagrams
44-Pin TSOP II Z44

51-85087-*A

MoBL is a registered trademark, and More Battery Life is a trademark, of Cypress Semiconductor. All product and company names mentioned in this document are the trademarks of their respective holders.



Document Title: CY62137V MoBL[®] 2M (128K x 16) Static RAM				
Document Number: 38-05051				
REV.	ECN NO.	Issue Date	Orig. of Change	Description of Change
**	109960	10/03/01	SZV	Changed from Spec number: 38-00738 to 38-05051
*A	116788	09/04/02	GBI	Added footnote number one. Added SL power bin. Deleted fBGA package; replacement fBGA package is available in CY62137CV30.
*B	237428	See ECN	AJU	Added Automotive product information



LittleDiode supplies new, hard to find or obsolete electronic components and semiconductors all over the world.

With over two million different components listed you are sure to find the part you need.

Feel free to visit us today at our online store:

LittleDiode.com

Looking forward to providing you with the best possible service.