



256K x 16 Static RAM

Features

- **High Speed**
 - 55 ns and 70 ns availability
- **Low voltage range:**
 - CY62147CV18: 1.65V–1.95V
- **Pin Compatible w/ CY62147V18/BV18**
- **Ultra-low active power**
 - Typical Active Current: 0.5 mA @ f = 1 MHz
 - Typical Active Current: 2 mA @ f = f_{max} (70 ns speed)
- **Low standby power**
- **Easy memory expansion with \overline{CE} and \overline{OE} features**
- **Automatic power-down when deselected**
- **CMOS for optimum speed/power**

Functional Description

The CY62147CV18 is a high-performance CMOS static RAM organized as 256K words by 16 bits. This device features advanced circuit design to provide ultra-low active current. This is ideal for providing More Battery Life™ (MoBL™) in portable applications such as cellular telephones. The device also has an automatic power-down feature that significantly reduces

power consumption by 99% when addresses are not toggling. The device can also be put into standby mode when deselected (\overline{CE} HIGH or both \overline{BLE} and \overline{BHE} are HIGH). The input/output pins (I/O_0 through I/O_{15}) are placed in a high-impedance state when: deselected (\overline{CE} HIGH), outputs are disabled (\overline{OE} HIGH), both Byte High Enable and Byte Low Enable are disabled (\overline{BHE} , \overline{BLE} HIGH), or during a write operation (\overline{CE} LOW and \overline{WE} LOW).

Writing to the device is accomplished by taking Chip Enable (\overline{CE}) and Write Enable (\overline{WE}) inputs LOW. If Byte Low Enable (\overline{BLE}) is LOW, then data from I/O pins (I/O_0 through I/O_7), is written into the location specified on the address pins (A_0 through A_{17}). If Byte High Enable (\overline{BHE}) is LOW, then data from I/O pins (I/O_8 through I/O_{15}) is written into the location specified on the address pins (A_0 through A_{17}).

Reading from the device is accomplished by taking Chip Enable (\overline{CE}) and Output Enable (\overline{OE}) LOW while forcing the Write Enable (\overline{WE}) HIGH. If Byte Low Enable (\overline{BLE}) is LOW, then data from the memory location specified by the address pins will appear on I/O_0 to I/O_7 . If Byte High Enable (\overline{BHE}) is LOW, then data from memory will appear on I/O_8 to I/O_{15} . See the Truth Table at the back of this data sheet for a complete description of read and write modes.

The CY62147CV18 is available in a 48-ball FBGA package.

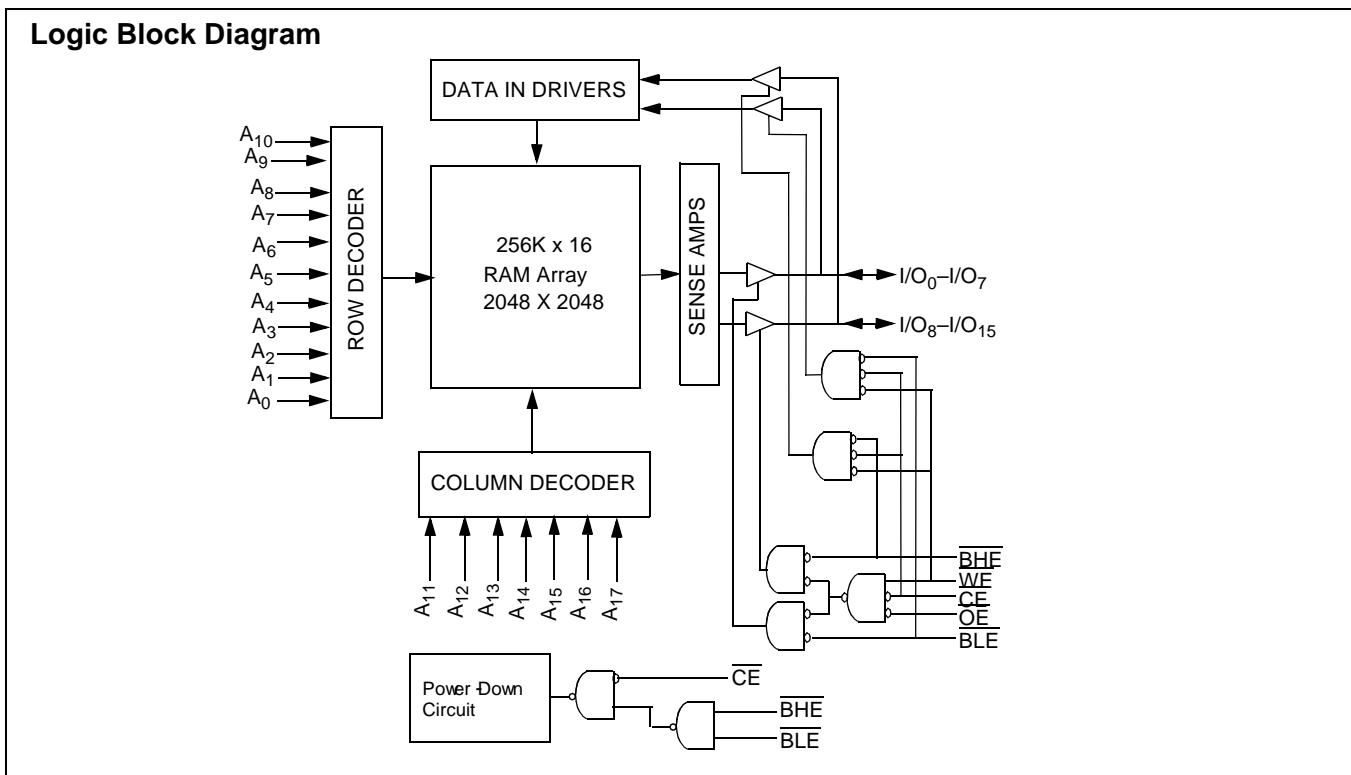

MoBL, MoBL2, and More Battery Life are trademarks of Cypress Semiconductor Corporation.

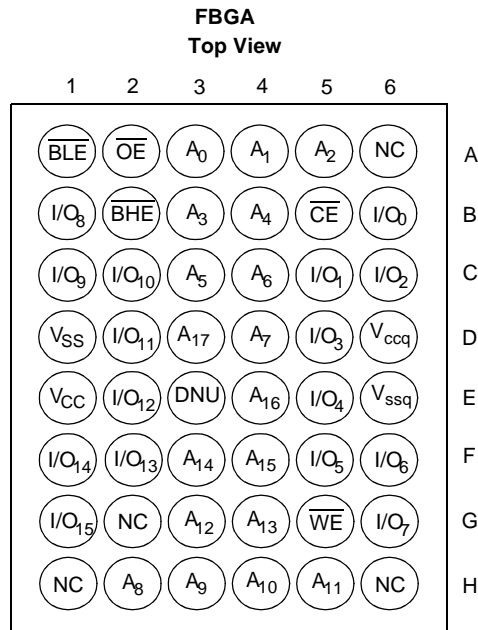
Pin Configuration^[1, 2]

Maximum Ratings

(Above which the useful life may be impaired. For user guidelines, not tested.)

Storage Temperature	-65°C to +150°C
Ambient Temperature with Power Applied.....	-55°C to +125°C
Supply Voltage to Ground Potential	-0.2V to +2.4V

DC Voltage Applied to Outputs

in High Z State^[3] -0.2V to $V_{CC} + 0.2V$

DC Input Voltage^[3]..... -0.2V to $V_{CC} + 0.2V$

Output Current into Outputs (LOW)..... 20 mA

Static Discharge Voltage >2001V (per MIL-STD-883, Method 3015)

Latch-Up Current..... >200 mA

Operating Range

Device	Range	Ambient Temperature	V_{CC}
CY62147CV18	Industrial	-40°C to +85°C	1.65V to 1.95V

Product Portfolio

Product	V _{CC} Range			Speed	Power Dissipation (Industrial)					
					Operating (I _{CC})				Standby (I _{SB2})	
	f = 1 MHz		f = f _{max}		Typ. ^[4]		Max.			
	V _{CC(min.)}	V _{CC(typ.)} ^[4]	V _{CC(max.)}						Typ. ^[4]	Max.
CY62147CV18	1.65V	1.80V	1.95V	55 ns	0.5 mA	3 mA	2.5 mA	7 mA	1 μA	10 μA
				70 ns	0.5 mA	3 mA	2 mA	6 mA		

Notes:

- NC pins are not connected to the die.
- E3 (DNU) can be left as NC or V_{SS} to ensure proper application.
- V_{IL} (min) = -2.0V for pulse durations less than 20 ns.
- Typical values are included for reference only and are not guaranteed or tested. Typical values are measured at $V_{CC} = V_{CC(typ)}$ Typ, $T_A = 25^\circ C$.

Electrical Characteristics Over the Operating Range

Parameter	Description	Test Conditions	CY62147CV18-55			CY62147CV18-70			Unit
			Min.	Typ. ^[4]	Max.	Min.	Typ. ^[4]	Max.	
V _{OH}	Output HIGH Voltage	I _{OH} = -0.1 mA V _{CC} = 1.65V	1.4			1.4			V
V _{OL}	Output LOW Voltage	I _{OL} = 0.1 mA V _{CC} = 1.65V			0.2			0.2	V
V _{IH}	Input HIGH Voltage		1.4		V _{CC} + 0.2V	1.4		V _{CC} + 0.2V	V
V _{IL}	Input LOW Voltage		-0.2		0.4	-0.2		0.4	V
I _{IX}	Input Leakage Current	GND ≤ V _I ≤ V _{CC}	-1		+1	-1		+1	μA
I _{OZ}	Output Leakage Current	GND ≤ V _O ≤ V _{CC} , Output Disabled	-1		+1	-1		+1	μA
I _{CC}	V _{CC} Operating Supply Current	f = f _{MAX} = 1/t _{RC} V _{CC} = 1.95V I _{OUT} = 0 mA CMOS levels		2.5	7		2	6	mA
		f = 1 MHz		0.5	3		0.5	3	mA
I _{SB1}	Automatic CE Power-Down Current— CMOS Inputs	$\overline{CE} \geq V_{CC} - 0.2V$, V _{IN} ≥ V _{CC} - 0.2V, V _{IN} ≤ 0.2V f = f _{MAX} (Address and Data Only), f = 0 (OE, WE, BHE, and BLE)		1	10		1	10	μA
I _{SB2}	Automatic CE Power-Down Current— CMOS Inputs	$\overline{CE} \geq V_{CC} - 0.2V$ V _{IN} ≥ V _{CC} - 0.2V or V _{IN} ≤ 0.2V, f = 0, V _{CC} = 1.95V							

Capacitance^[5]

Parameter	Description	Test Conditions	Max.	Unit
C _{IN}	Input Capacitance	T _A = 25°C, f = 1 MHz, V _{CC} = V _{CC} (typ)	6	pF
C _{OUT}	Output Capacitance		8	pF

Thermal Resistance

Description	Test Conditions	Symbol	BGA	Unit
Thermal Resistance (Junction to Ambient) ^[5]	Still Air, soldered on a 4.25 x 1.125 inch, 4-layer printed circuit board	Θ _{JA}	55	°C/W
Thermal Resistance (Junction to Case) ^[5]		Θ _{JC}	16	°C/W

Note:

5. Tested initially and after any design or process changes that may affect these parameters.

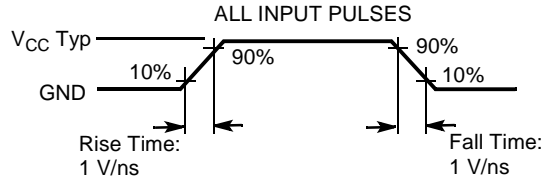
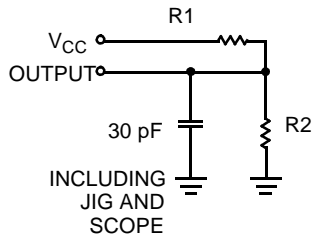
AC Test Loads and Waveforms

Equivalent to: THÉVENIN EQUIVALENT

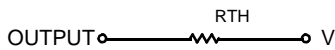

Parameters	1.8V	UNIT
R1	13500	Ohms
R2	10800	Ohms
R _{TH}	6000	Ohms
V _{TH}	0.80	Volts

Data Retention Characteristics (Over the Operating Range)

Parameter	Description	Conditions	Min.	Typ. ^[4]	Max.	Unit
V _{DR}	V _{CC} for Data Retention		1.0		1.95	V
I _{CCDR}	Data Retention Current	V _{CC} = 1.0V CE ≥ V _{CC} - 0.2V, V _{IN} ≥ V _{CC} - 0.2V or V _{IN} ≤ 0.2V		1	8	μA
t _{CDR} ^[5]	Chip Deselect to Data Retention Time		0			ns
t _R ^[6]	Operation Recovery Time		t _{RC}			ns

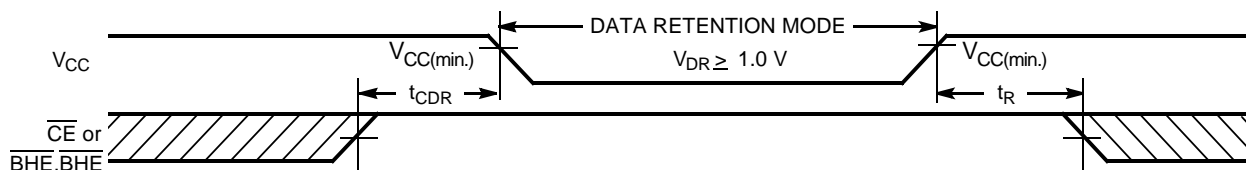
Data Retention Waveform^[7]

Notes:

- Full device operation requires linear V_{CC} ramp from V_{DR} to V_{CC(min)} ≥ 100 μs or stable at V_{CC(min)} ≥ 100 μs.
- BHE.BLE is the AND of both BHE and BLE. Chip can be deselected by either disabling the chip enable signals or by disabling both BHE and BLE.

Switching Characteristics Over the Operating Range^[8]

Parameter	Description	55 ns		70 ns		Unit
		Min.	Max.	Min.	Max.	
READ CYCLE						
t _{RC}	Read Cycle Time	55		70		ns
t _{AA}	Address to Data Valid		55		70	ns
t _{OHA}	Data Hold from Address Change	10		10		ns
t _{ACE}	\overline{CE} LOW to Data Valid		55		70	ns
t _{DOE}	\overline{OE} LOW to Data Valid		25		35	ns
t _{LZOE}	\overline{OE} LOW to Low Z ^[9]	5		5		ns
t _{HZOE}	\overline{OE} HIGH to High Z ^[9, 10]		20		25	ns
t _{LZCE}	\overline{CE} LOW to Low Z ^[9]	5		10		ns
t _{HZCE}	\overline{CE} HIGH to High Z ^[9, 10]		20		25	ns
t _{PU}	\overline{CE} LOW to Power-Up	0		0		ns
t _{PD}	\overline{CE} HIGH to Power-Down		55		70	ns
t _{DBE}	$\overline{BLE}/\overline{BHE}$ LOW to Data Valid		55		70	ns
t _{LZBE}	$\overline{BLE}/\overline{BHE}$ LOW to Low Z ^[9]	5		5		ns
t _{HZBE}	$\overline{BLE}/\overline{BHE}$ HIGH to High Z ^[9, 10]		20		25	ns
WRITE CYCLE^[11]						
t _{WC}	Write Cycle Time	55		70		ns
t _{SCE}	\overline{CE} LOW to Write End	40		60		ns
t _{AW}	Address Set-Up to Write End	40		60		ns
t _{HA}	Address Hold from Write End	0		0		ns
t _{SA}	Address Set-Up to Write Start	0		0		ns
t _{PWE}	\overline{WE} Pulse Width	40		50		ns
t _{BW}	$\overline{BLE}/\overline{BHE}$ LOW to Write End	40		60		ns
t _{SD}	Data Set-Up to Write End	25		30		ns
t _{HD}	Data Hold from Write End	0		0		ns
t _{HZWE}	\overline{WE} LOW to High Z ^[9, 10]		15		25	ns
t _{LZWE}	\overline{WE} HIGH to Low Z ^[9]	5		10		ns

Notes:

8. Test conditions assume signal transition time of 3ns or less, timing reference levels of $V_{CC(typ)}/2$, input pulse levels of 0 to $V_{CC(typ)}$, and output loading of the specified I_{OL}/I_{OH} and 30-pF load capacitance.
9. At any given temperature and voltage condition, t_{HZCE} is less than t_{LZCE}, t_{HZBE} is less than t_{LZBE}, t_{HZOE} is less than t_{LZOE}, and t_{HZWE} is less than t_{LZWE} for any given device.
10. t_{HZOE}, t_{HZCE}, t_{HZBE}, and t_{HZWE} transitions are measured when the outputs enter a high impedance state.
11. The internal write time of the memory is defined by the overlap of \overline{WE} , $\overline{CE} = V_{IL}$, \overline{BHE} and/or $\overline{BLE} = V_{IL}$. All signals must be ACTIVE to initiate a write and any of these signals can terminate a write by going INACTIVE. The data input set-up and hold timing should be referenced to the edge of the signal that terminates the write.

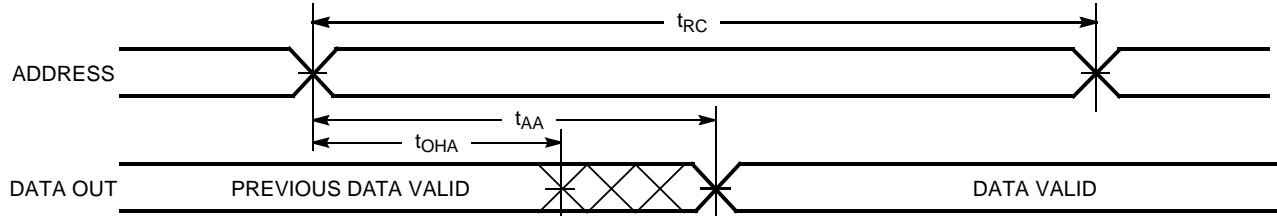
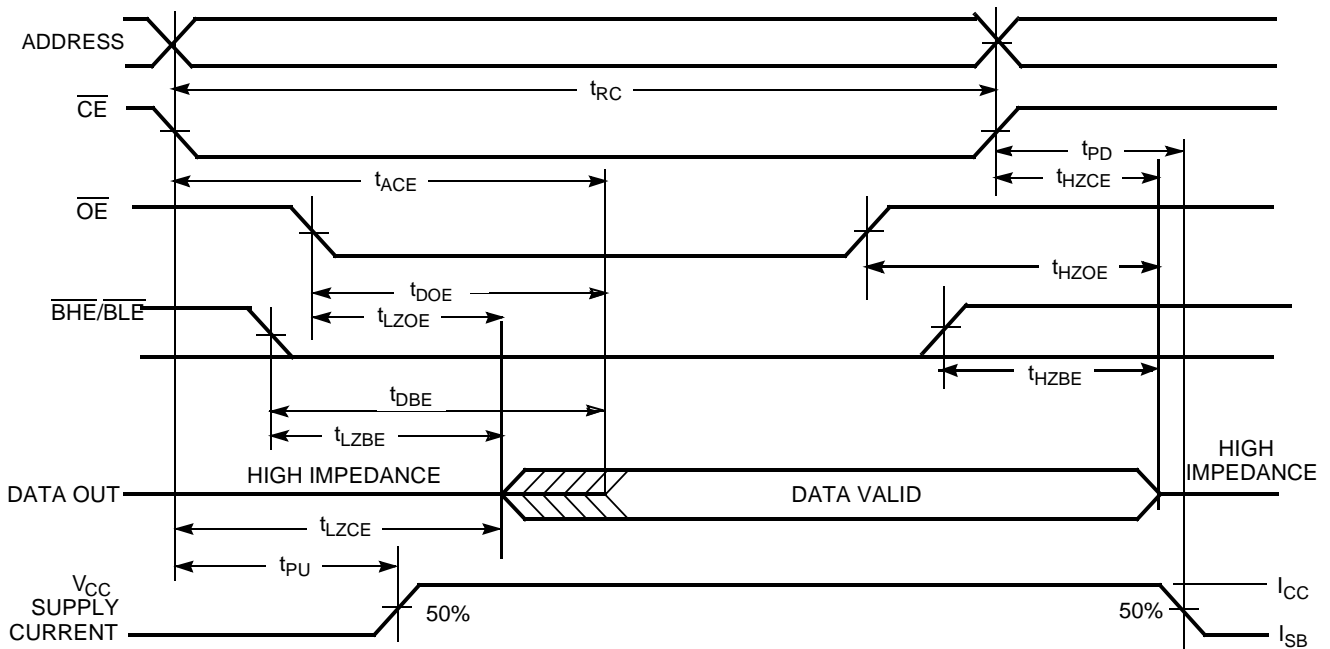
Switching Waveforms
Read Cycle No. 1 (Address Transition Controlled) ^[12, 13]

Read Cycle No. 2 (\overline{OE} Controlled) ^[13, 14]

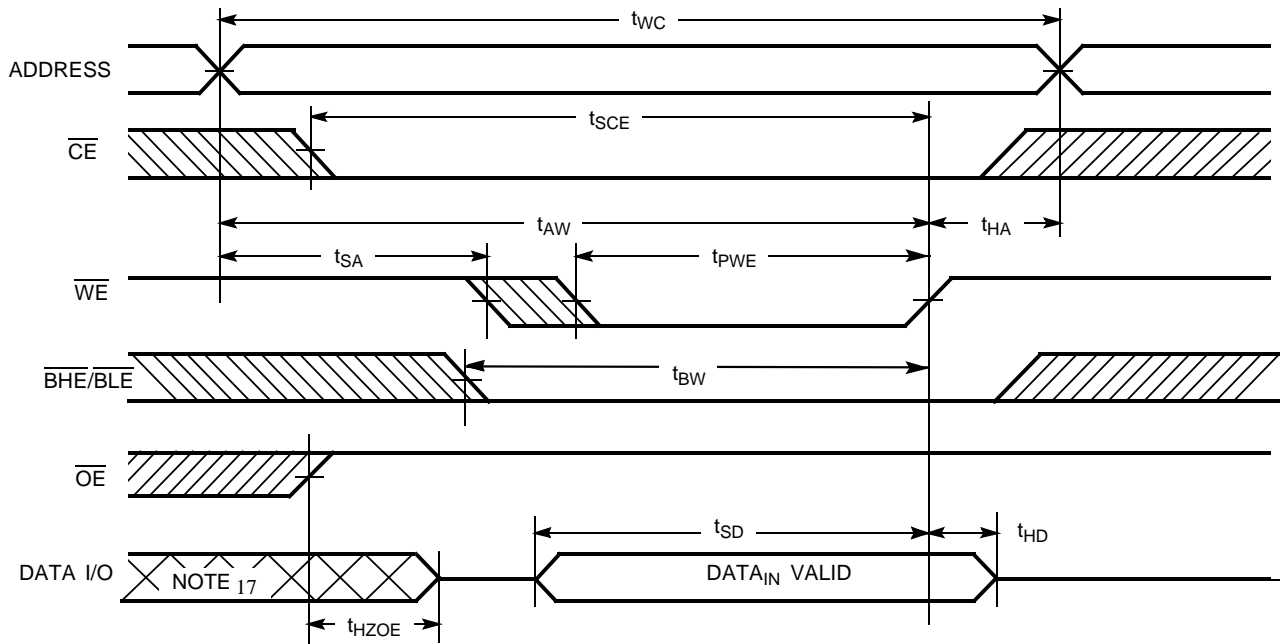
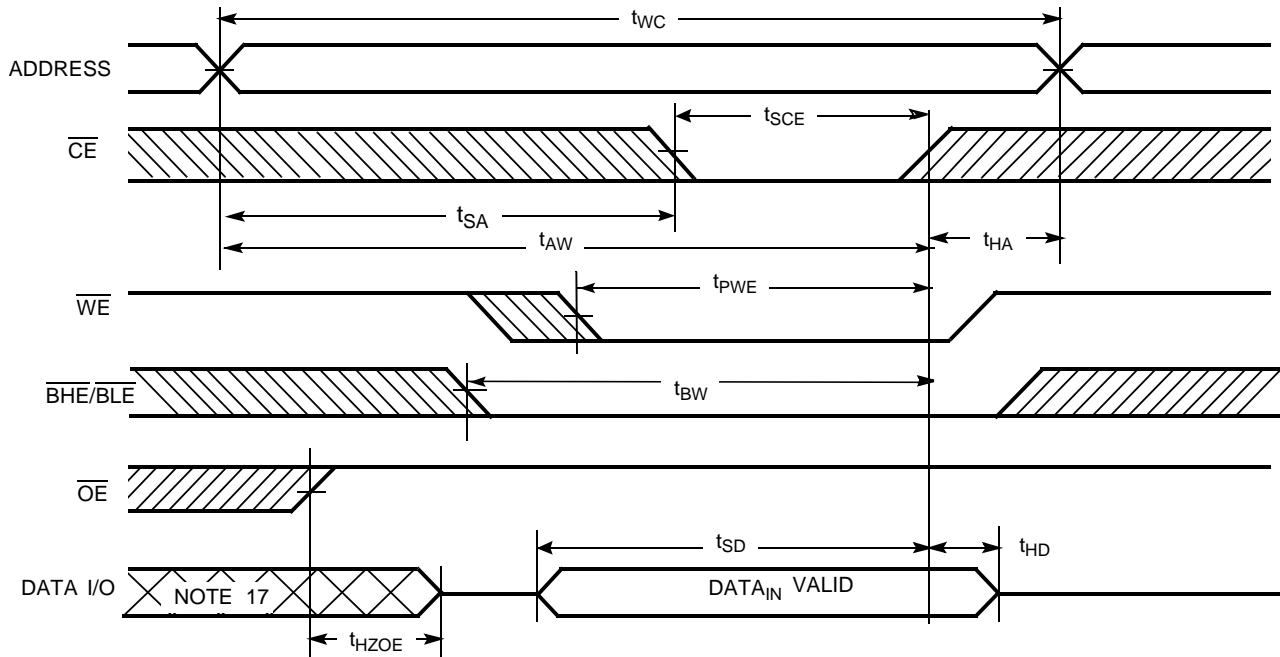
Notes:

12. Device is continuously selected. \overline{OE} , $\overline{CE} = V_{IL}$, \overline{BHE} and/or $\overline{BLE} = V_{IL}$.
13. \overline{WE} is HIGH for read cycle.
14. Address valid prior to or coincident with \overline{CE} , \overline{BHE} , \overline{BLE} , transition LOW.

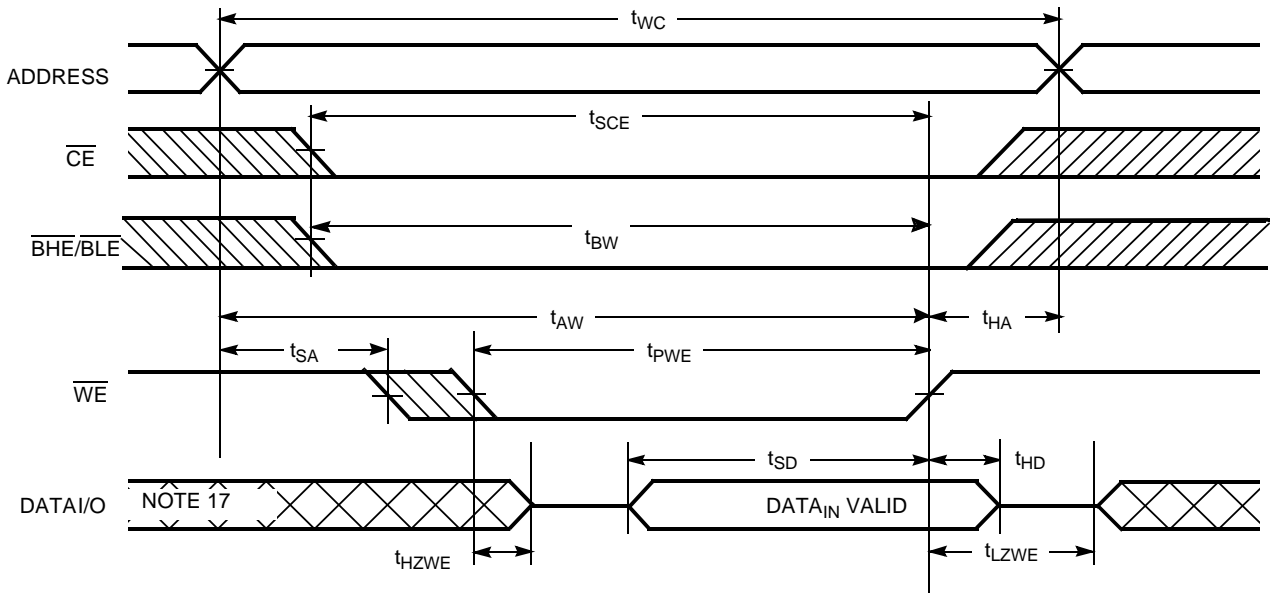
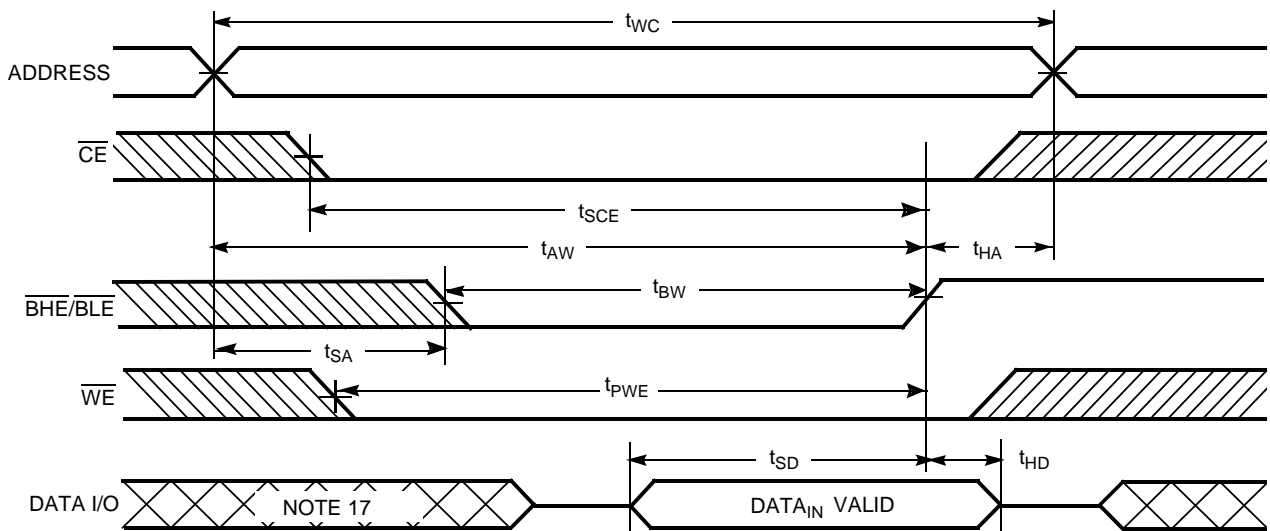
Switching Waveforms
Write Cycle No. 1 (WE Controlled)^[11, 15, 16]

Write Cycle No. 2 (\overline{CE} Controlled)^[11, 15, 16]

Notes:

15. Data I/O is high impedance if $\overline{OE} = V_{IH}$.
16. If \overline{CE} goes HIGH simultaneously with \overline{WE} HIGH, the output remains in a high-impedance state.
17. During this period, the I/Os are in output state and input signals should not be applied.

Switching Waveforms
Write Cycle No. 3 ($\overline{\text{WE}}$ Controlled, $\overline{\text{OE}}$ LOW)^[16]

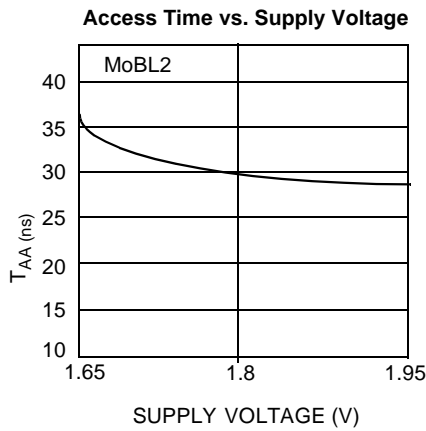
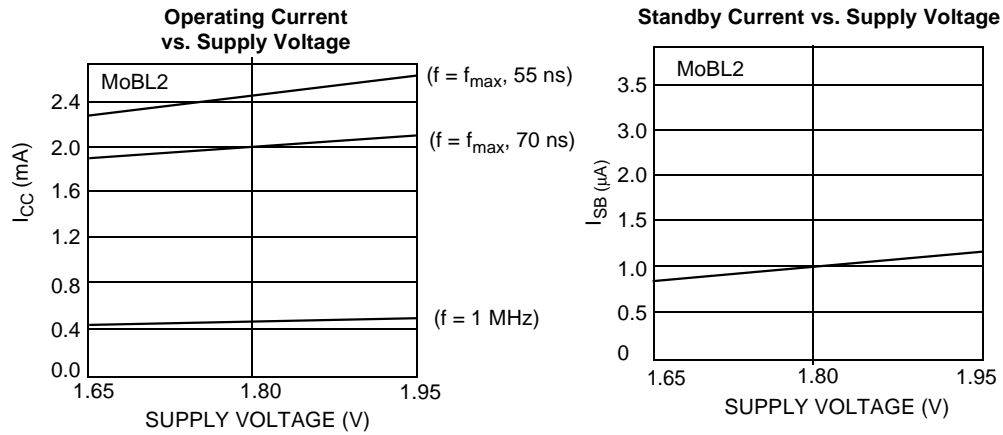
Write Cycle No. 4 ($\overline{\text{BHE/BLE}}$ Controlled, $\overline{\text{OE}}$ LOW)^[16]

Typical DC and AC Characteristics

(Typical values are included for reference only and are not guaranteed or tested. Typical values are measured at $V_{CC} = V_{CC \text{ Typ}}$, $T_A = 25^\circ\text{C}$.)



Truth Table

CE	WE	OE	BHE	BLE	Inputs/Outputs	Mode	Power
H	X	X	X	X	High Z	Deselect/Power-Down	Standby (I_{SB})
X	X	X	H	H	High Z	Deselect/Power-Down	Standby (I_{SB})
L	H	L	L	L	Data Out (I/O ₀ –I/O ₁₅)	Read	Active (I_{CC})
L	H	L	H	L	Data Out (I/O ₀ –I/O ₇); I/O ₈ –I/O ₁₅ in High Z	Read	Active (I_{CC})
L	H	L	L	H	Data Out (I/O ₈ –I/O ₁₅); I/O ₀ –I/O ₇ in High Z	Read	Active (I_{CC})
L	H	H	L	L	High Z	Output Disabled	Active (I_{CC})
L	H	H	H	L	High Z	Output Disabled	Active (I_{CC})
L	H	H	L	H	High Z	Output Disabled	Active (I_{CC})
L	L	X	L	L	Data In (I/O ₀ –I/O ₁₅)	Write	Active (I_{CC})
L	L	X	H	L	Data In (I/O ₀ –I/O ₇); I/O ₈ –I/O ₁₅ in High Z	Write	Active (I_{CC})
L	L	X	L	H	Data In (I/O ₈ –I/O ₁₅); I/O ₀ –I/O ₇ in High Z	Write	Active (I_{CC})

Ordering Information^[18]

Speed (ns)	Ordering Code	Package Name	Package Type	Operating Range
70	CY62147CV18LL-70BAI	BA48B	48-Ball Fine Pitch BGA (7 mm x 8.5 mm x 1.2 mm)	Industrial
	CY62147CV18LL-70BVI	BV48A	48-Ball Fine Pitch BGA (6 mm x 8 mm x 1 mm)	
55	CY62147CV18LL-55BAI	BA48B	48-Ball Fine Pitch BGA (7 mm x 8.5 mm x 1.2 mm)	
	CY62147CV18LL-55BVI	BV48A	48-Ball Fine Pitch BGA (6 mm x 8 mm x 1 mm)	

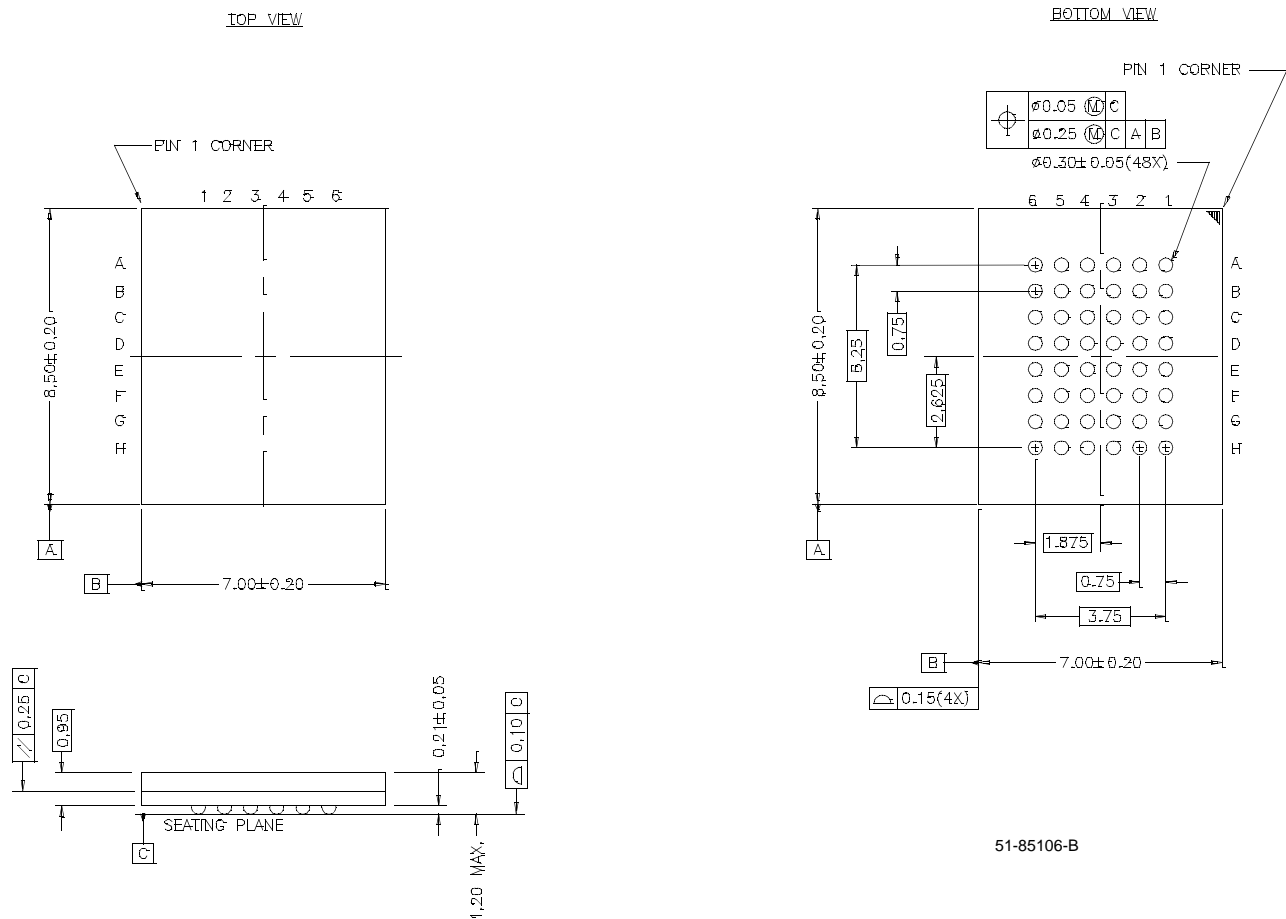
Package Diagrams
48-Ball (7 mm x 8.5 mm x 1.2 mm) Fine Pitch BGA BA48B

Note:

18. Gray Shading represents preliminary information.

Package Diagrams (continued)

48-Ball (6 mm x 8 mm x 1 mm) Fine Pitch BGA BV48A

Top View

Bottom View

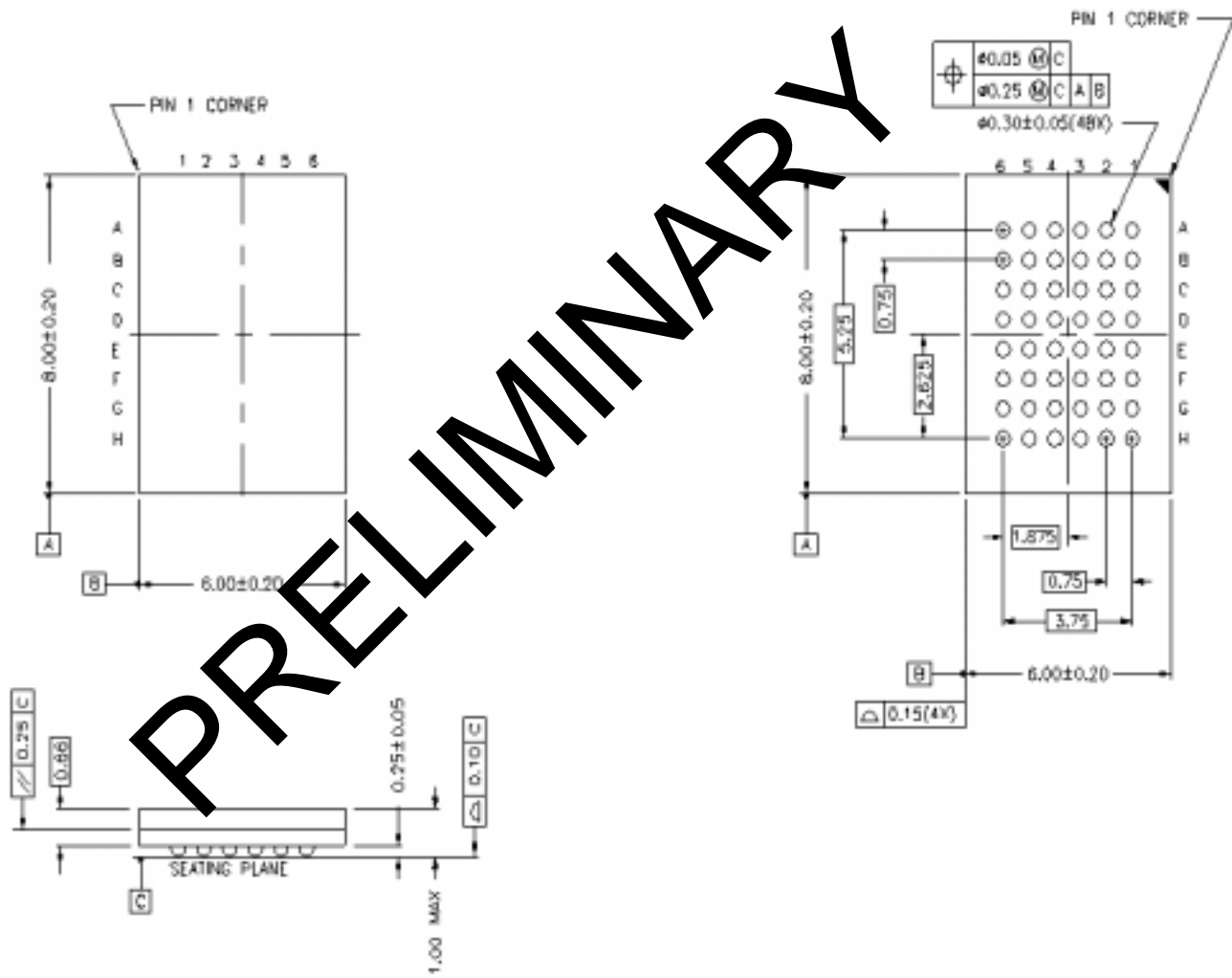

PRELIMINARY

Document Title: CY62147CV18 MoBL2™, 256K x 16 Static RAM Document Number: 38-05011				
REV.	ECN NO.	Issue Date	Orig. of Change	Description of Change
**	106265	5/7/01	HRT/MGN	New Data Sheet
*A	108941	08/24/01	MGN	From Preliminary to Final
*B	110573	11/02/01	MGN	Improved I_{SB} Typ. from 1.5 μ A to 1 μ A. Improved Typical DC & AC Characteristics graphs. Improved Switching Characteristics: t_{OHA} , t_{LZCE} . Add preliminary package diagram of BV48A. Format standardization



LittleDiode supplies new, hard to find or obsolete electronic components and semiconductors all over the world.

With over two million different components listed you are sure to find the part you need.

Feel free to visit us today at our online store:

LittleDiode.com

Looking forward to providing you with the best possible service.