



512K x 8 MoBL Static RAM

Features

- Low voltage range:
— 2.7V–3.6V
- Ultra low active power
- Low standby power
- TTL-compatible inputs and outputs
- Automatic power-down when deselected
- CMOS for optimum speed/power

Functional Description

The CY62148V is a high-performance CMOS static RAM organized as 524,288 words by 8 bits. This device features advanced circuit design to provide ultra-low active current. This is ideal for providing More Battery Life™ (MoBL™) in portable applications such as cellular telephones. The device also has an automatic power-down feature that significantly reduces power consumption by 99% when addresses are not toggling.

The device can be put into standby mode when deselected (\overline{CE} HIGH).

Writing to the device is accomplished by taking Chip Enable (\overline{CE}) and Write Enable (\overline{WE}) inputs LOW. Data on the eight I/O pins (I/O_0 through I/O_7) is then written into the location specified on the address pins (A_0 through A_{18}).

Reading from the device is accomplished by taking Chip Enable (\overline{CE}) and Output Enable (\overline{OE}) LOW while forcing Write Enable (\overline{WE}) HIGH. Under these conditions, the contents of the memory location specified by the address pins will appear on the I/O pins.

The eight input/output pins (I/O_0 through I/O_7) are placed in a high-impedance state when the device is deselected (\overline{CE} HIGH), the outputs are disabled (\overline{OE} HIGH), or during a write operation (\overline{CE} LOW and \overline{WE} LOW).

The CY62148V is available in a 36-ball FBGA, 32 pin TSOPII, and a 32-pin SOIC package.

Logic Block Diagram

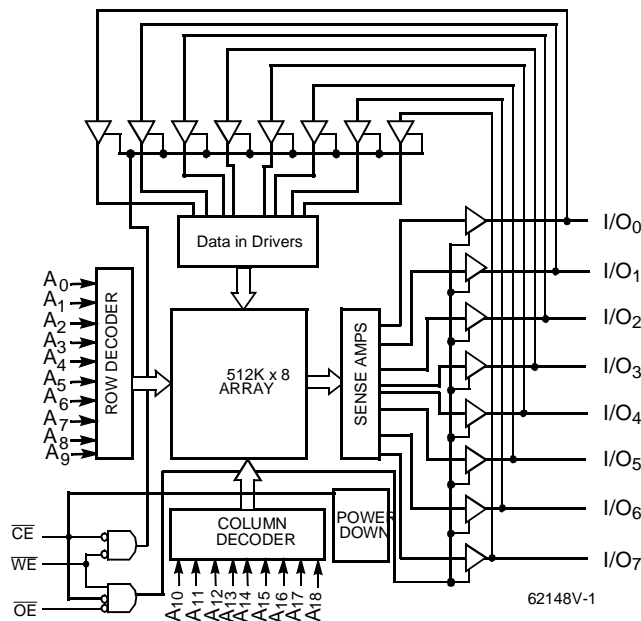

Pin Configurations

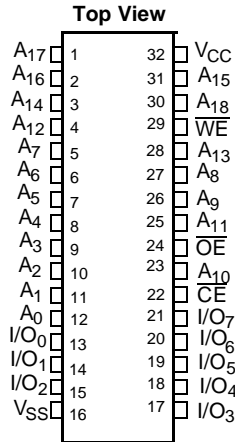
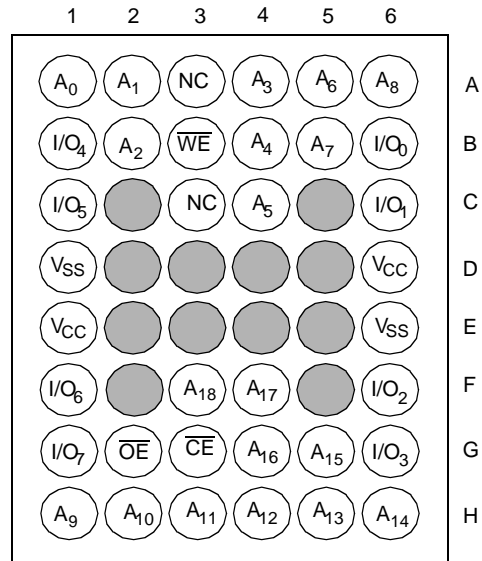
TSOPII/SOIC

**FBGA
Top View**

62148V-2

Maximum Ratings

(Above which the useful life may be impaired. For user guidelines, not tested.)

Storage Temperature -65°C to +150°C

Ambient Temperature with

Power Applied 55°C to +125°C

Supply Voltage to Ground Potential -0.5V to +4.6V

DC Voltage Applied to Outputs
in High Z State^[1] -0.5V to V_{CC} + 0.5V

DC Input Voltage^[1] -0.5V to V_{CC} + 0.5V

Output Current into Outputs (LOW) 20 mA

Static Discharge Voltage >2001V
(per MIL-STD-883, Method 3015)

Latch-Up Current >200 mA

Operating Range

Range	Ambient Temperature	V _{CC}
Industrial	-40°C to +85°C	2.7V to 3.6V

Product Portfolio

Product	V _{CC} Range			Speed	Power Dissipation (Industrial)			
					Operating (I _{CC})		Standby (I _{SB2})	
	Min.	Typ. ^[2]	Max.		Typ. ^[2]	Maximum	Typ. ^[2]	Maximum
CY62148V	2.7V	3.0V	3.6V	70 ns	7	15 mA	2 μA	20 μA

Notes:

1. V_{IL(min.)} = -2.0V for pulse durations less than 20 ns.

2. Typical values are included for reference only and are not guaranteed or tested. Typical values are measured at V_{CC} = V_{CC(typ.)}, T_A = 25°C.

Electrical Characteristics Over the Operating Range

Parameter	Description	Test Conditions		CY62148V			Unit
				Min.	Typ. ^[2]	Max.	
V _{OH}	Output HIGH Voltage	I _{OH} = -1.0 mA	V _{CC} = 2.7V	2.4			V
V _{OL}	Output LOW Voltage	I _{OL} = 2.1 mA	V _{CC} = 2.7V			0.4	V
V _{IH}	Input HIGH Voltage		V _{CC} = 3.6V	2.2		V _{CC} + 0.5V	V
V _{IL}	Input LOW Voltage		V _{CC} = 2.7V	-0.5		0.8	V
I _{IX}	Input Load Current	GND ≤ V _I ≤ V _{CC}		-1	±1	+1	μA
I _{OZ}	Output Leakage Current	GND ≤ V _O ≤ V _{CC} , Output Disabled		-1	±1	+1	μA
I _{CC}	V _{CC} Operating Supply Current	I _{OUT} = 0 mA, (f = f _{MAX} = 1/t _{RC}) CMOS Levels	V _{CC} = 3.6V		7	15	mA
		I _{OUT} = 0 mA, f = 1 MHz CMOS Levels			1	2	mA
I _{SB1}	Automatic CE Power-Down Current—CMOS Inputs	$\overline{CE} \geq V_{CC} - 0.3V$, V _{IN} ≥ V _{CC} - 0.3V or V _{IN} ≤ 0.3V, f = f _{MAX}				100	μA
I _{SB2}	Automatic CE Power-Down Current—CMOS Inputs	$\overline{CE} \geq V_{CC} - 0.3V$ V _{IN} ≥ V _{CC} - 0.3V or V _{IN} ≤ 0.3V, f = 0	L		1	50	μA
			V _{CC} = 3.6V LL		2	20	μA

Capacitance^[3]

Parameter	Description	Test Conditions	Max.	Unit
C _{IN}	Input Capacitance	T _A = 25°C, f = 1 MHz, V _{CC} = 3.0V	6	pF
C _{OUT}	Output Capacitance		8	pF

Thermal Resistance

Description	Test Conditions	Symbol	Others	BGA	Units
Thermal Resistance ^[3] (Junction to Ambient)	Still Air, soldered on a 4.25 x 1.125 inch, 4-layer printed circuit board	Θ _{JA}	TBD	TBD	°C/W
Thermal Resistance ^[3] (Junction to Case)		Θ _{JC}	TBD	TBD	°C/W

Note:

3. Tested initially and after any design or process changes that may affect these parameters.

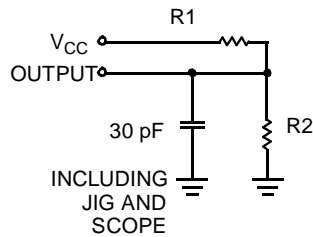
AC Test Loads and Waveforms

62148V-3

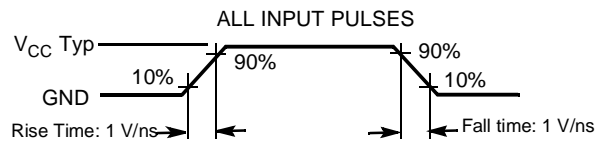

62148V-4

Equivalent to: THEVENIN EQUIVALENT

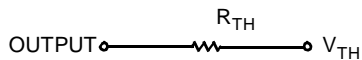

Parameters	3.0V	Unit
R1	1105	Ohms
R2	1550	Ohms
R_{TH}	645	Ohms
V_{TH}	1.75V	Volts

Data Retention Characteristics (Over the Operating Range)

Parameter	Description	Conditions	Min.	Typ. ^[2]	Max.	Unit
V_{DR}	V_{CC} for Data Retention		1.0		3.6	V
I_{CCDR}	Data Retention Current	$V_{CC} = 1.0V$ $CE \geq V_{CC} - 0.3V$, $V_{IN} \geq V_{CC} - 0.3V$ or $V_{IN} \leq 0.3V$ No input may exceed $V_{CC} + 0.3V$	L/LL	0.2	5.5	μA
$t_{CDR}^{[3]}$	Chip Deselect to Data Retention Time		0			ns
$t_R^{[4]}$	Operation Recovery Time		t_{RC}			ns

Note:

4. Full Device AC operation requires linear V_{CC} ramp from V_{DR} to $V_{CC(min.)} \geq 10 \mu s$ or stable at $V_{CC(min.)} \geq 10 \mu s$.

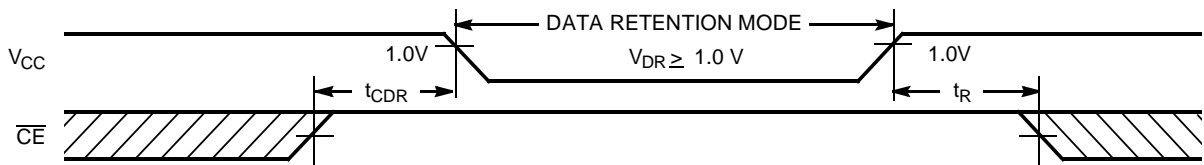
Data Retention Waveform

62148V-5

Switching Characteristics Over the Operating Range^[5]

Parameter	Description	(2.7V–3.6V Operation)		Unit
		Min.	Max.	
READ CYCLE				
t_{RC}	Read Cycle Time	70		ns
t_{AA}	Address to Data Valid		70	ns
t_{OHA}	Data Hold from Address Change	10		ns
t_{ACE}	\overline{CE} LOW to Data Valid		70	ns
t_{DOE}	\overline{OE} LOW to Data Valid		35	ns
t_{LZOE}	\overline{OE} LOW to Low Z ^[6]	5		ns
t_{HZOE}	\overline{OE} HIGH to High Z ^[7]		25	ns
t_{LZCE}	\overline{CE} LOW to Low Z ^[6]	10		ns
t_{HZCE}	\overline{CE} HIGH to High Z ^[6, 7]		25	ns
t_{PU}	\overline{CE} LOW to Power-Up	0		ns
t_{PD}	\overline{CE} HIGH to Power-Down		70	ns
WRITE CYCLE^[8, 9]				
t_{WC}	Write Cycle Time	70		ns
t_{SCE}	\overline{CE} LOW to Write End	60		ns
t_{AW}	Address Set-Up to Write End	60		ns
t_{HA}	Address Hold from Write End	0		ns
t_{SA}	Address Set-Up to Write Start	0		ns
t_{PWE}	\overline{WE} Pulse Width	50		ns
t_{SD}	Data Set-Up to Write End	30		ns
t_{HD}	Data Hold from Write End	0		ns
t_{HZWE}	\overline{WE} LOW to High Z ^[6, 7]		25	ns
t_{LZWE}	\overline{WE} HIGH to Low Z ^[6]	10		ns

Notes:

5. Test conditions assume signal transition time of 5 ns or less, timing reference levels of 1.5V, input pulse levels of 0 to $V_{CC(typ.)}$, and output loading of the specified I_{OL}/I_{OH} and 30 pF load capacitance.
6. At any given temperature and voltage condition, t_{HZCE} is less than t_{LZCE} , t_{HZOE} is less than t_{LZOE} , and t_{HZWE} is less than t_{LZWE} for any given device.
7. t_{HZOE} , t_{HZCE} , and t_{HZWE} are specified with $C_L = 5$ pF as in part (b) of AC Test Loads. Transition is measured ± 200 mV from steady-state voltage.
8. The internal write time of the memory is defined by the overlap of \overline{CE} LOW and \overline{WE} LOW. Both signals must be LOW to initiate a write and either signal can terminate a write by going HIGH. The data input set-up and hold timing should be referenced to the rising edge of the signal that terminates the write.
9. The minimum write cycle time for Write Cycle #3 (\overline{WE} controlled, \overline{OE} LOW) is the sum of t_{HZWE} and t_{SD} .

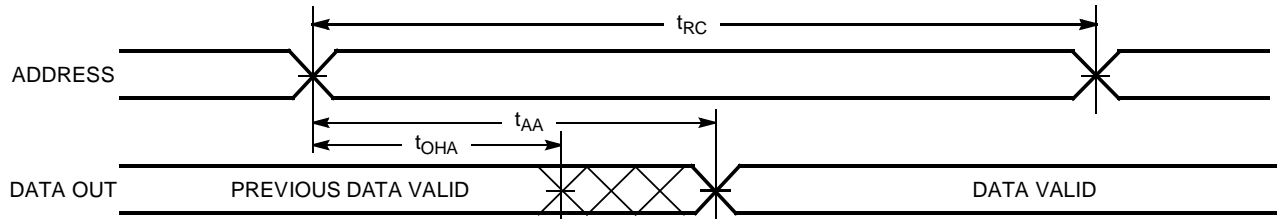
Switching Waveforms
Read Cycle No. 1^[10, 11]

62148V-6

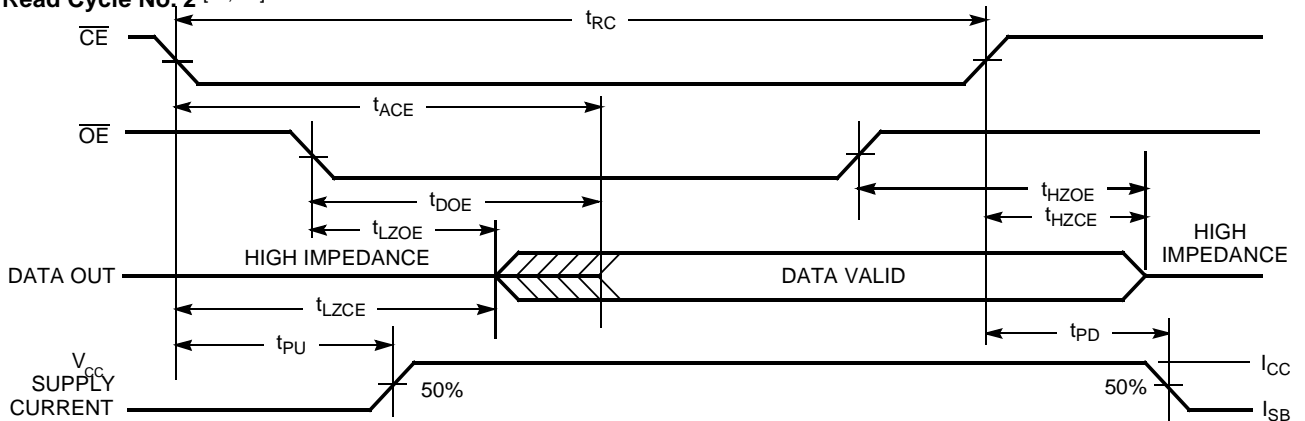
Read Cycle No. 2^[11, 12]

62148V-7

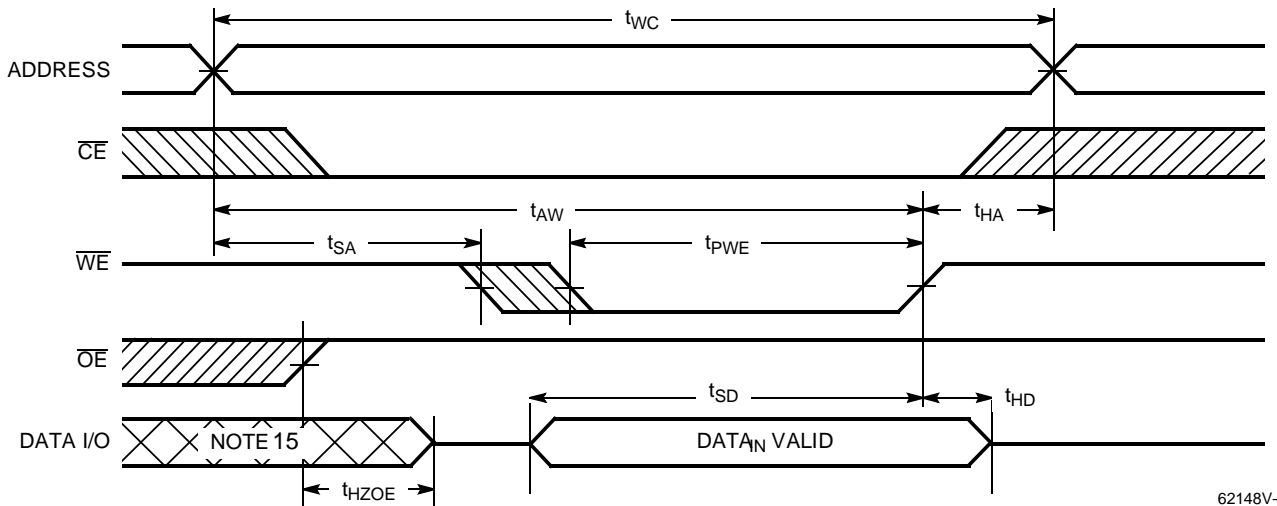
Write Cycle No. 1 (WE Controlled)^[8, 13, 14]

62148V-8

Notes:

10. Device is continuously selected. \overline{OE} , $\overline{CE} = V_{IL}$.
11. \overline{WE} is HIGH for read cycle.
12. Address valid prior to or coincident with \overline{CE} transition LOW.
13. Data I/O is high impedance if $\overline{OE} = V_{IH}$.
14. If \overline{CE} goes HIGH simultaneously with \overline{WE} HIGH, the output remains in a high-impedance state.
15. During this period, the I/Os are in output state and input signals should not be applied.

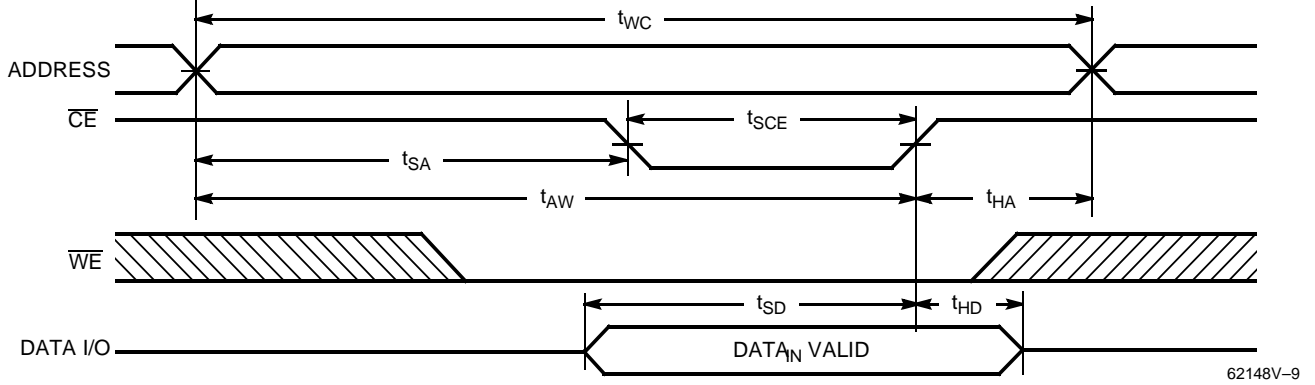
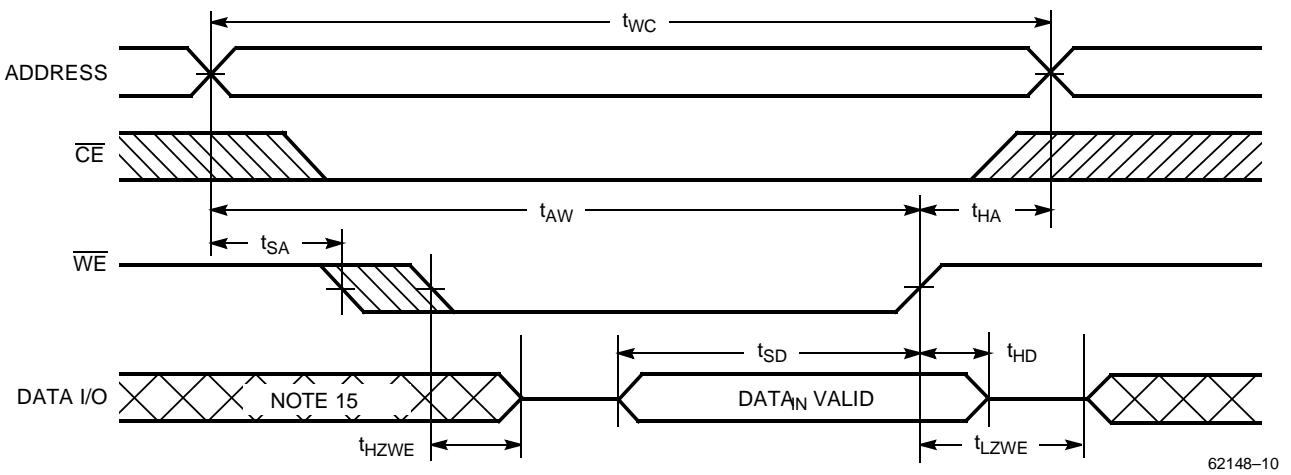
Switching Waveforms (continued)
Write Cycle No. 2 (\overline{CE} Controlled) [8, 13, 14]

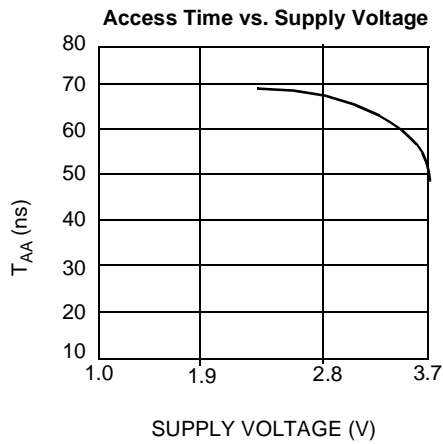
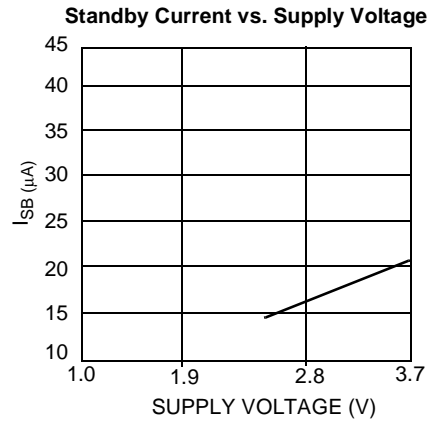
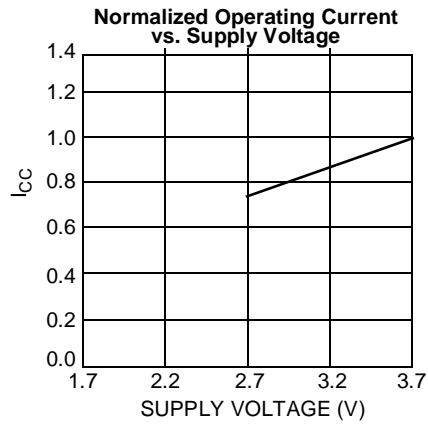
Write Cycle No. 3 (\overline{WE} Controlled, \overline{OE} LOW) [9, 14]

Typical DC and AC Characteristics

Truth Table

\overline{CE}	\overline{WE}	\overline{OE}	Inputs/Outputs	Mode	Power
H	X	X	High Z	Deselect/Power-Down	Standby (I_{SB})
L	H	L	Data Out	Read	Active (I_{CC})
L	L	X	Data In	Write	Active (I_{CC})
L	H	H	High Z	Output Disabled	Active (I_{CC})

Ordering Information

Speed (ns)	Ordering Code	Package Name	Package Type	Operating Range
70	CY62148VLL-70BAI	BA37	36-Ball Fine Pitch BGA	Industrial
	CY62148VLL-70ZI	ZS32	32-Lead TSOPII	
	CY62148VLL-70SI	S34	32-Lead 450 mil. molded SOIC	

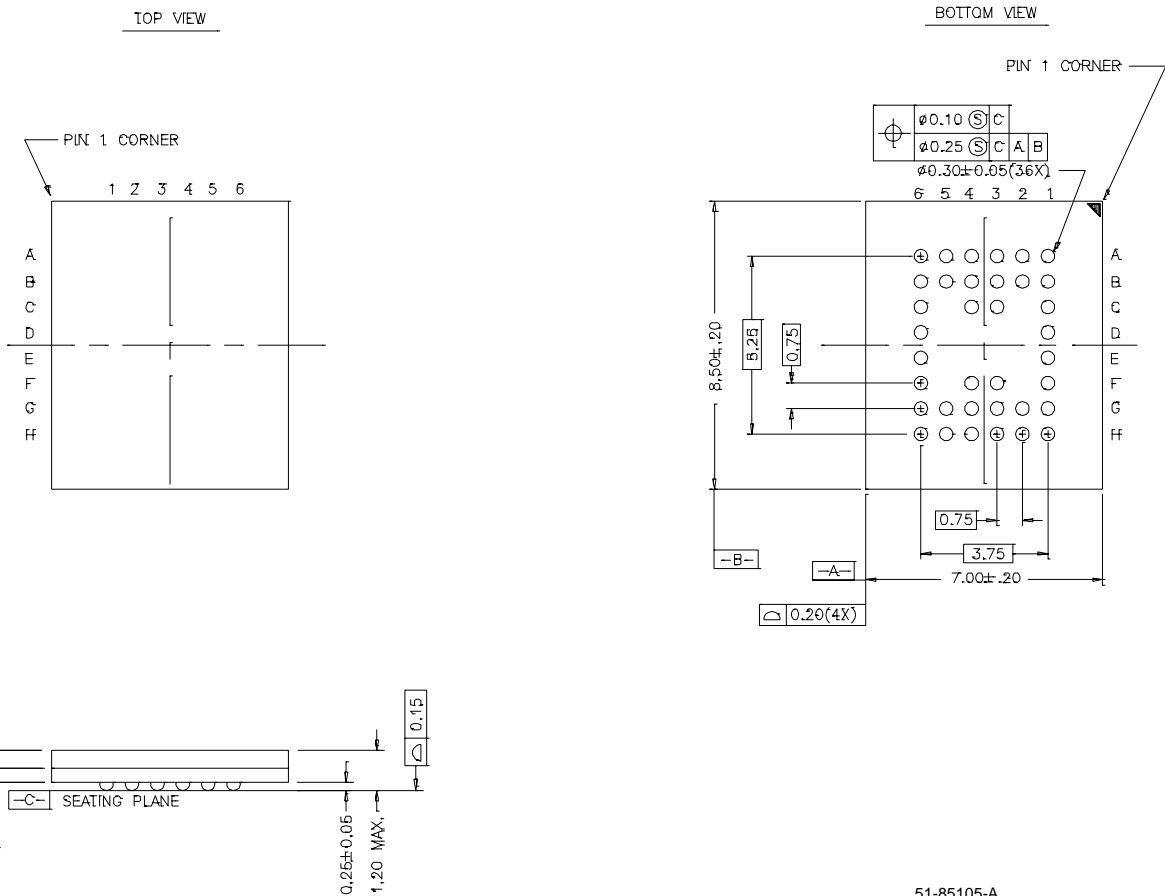
Document #: 38-00646-C

Package Diagrams
36-Ball (7.00 mm x 8.5 mm x 1.5 mm) Thin BGA BA37

51-85105-A

* THE BALL DIAMETER, BALL PITCH, STAND-OFF & PACKAGE THICKNESS ARE DIFFERENT FROM JEDEC SPEC M0192 (LOW PROFILE BGA FAMILY)

Package Diagrams (continued)

32-Lead (450 MIL) Molded SOIC S34

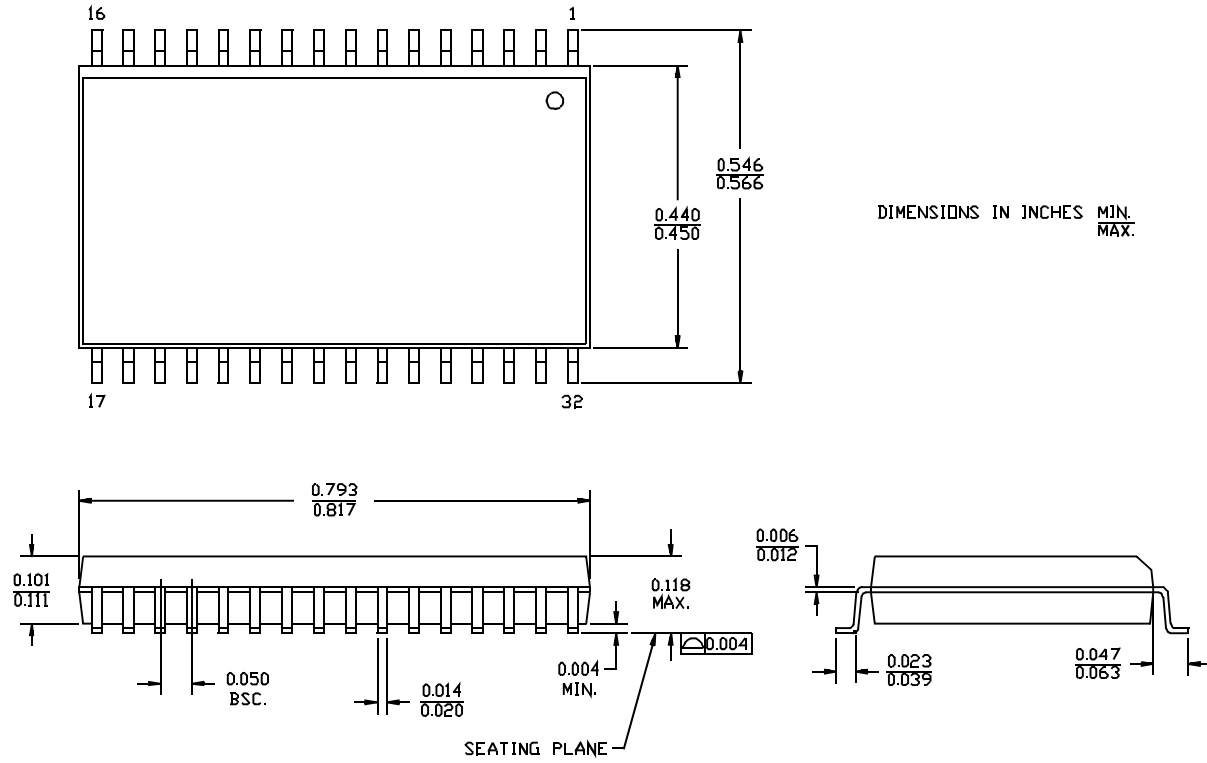

Package Diagrams (continued)

32-Lead TSOP II ZS32

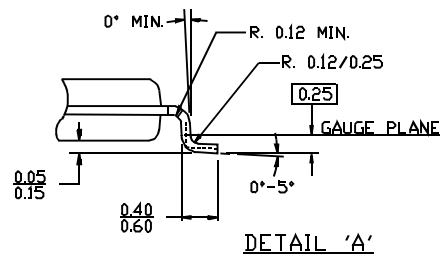
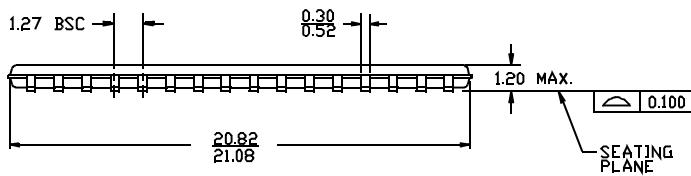
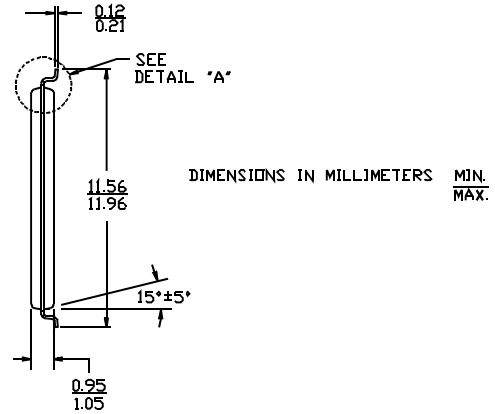
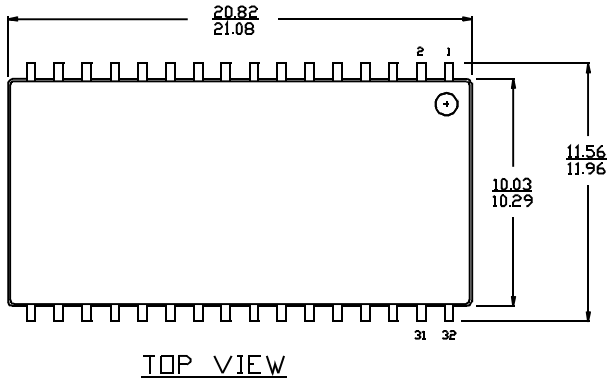

51-85095

This datasheet has been downloaded from:

www.DatasheetCatalog.com

Datasheets for electronic components.



LittleDiode supplies new, hard to find or obsolete electronic components and semiconductors all over the world.

With over two million different components listed you are sure to find the part you need.

Feel free to visit us today at our online store:

LittleDiode.com

Looking forward to providing you with the best possible service.