

4-Mbit (256K x 16) Static RAM

Features

- Pin equivalent to CY7C1041BV33
- Temperature Ranges
 - Commercial: 0°C to 70°C
 - Industrial: -40°C to 85°C
 - Automotive: -40°C to 125°C
- High speed
 - $t_{AA} = 10$ ns
- Low active power
 - 324 mW (max.)
- 2.0V data retention
- Automatic power-down when deselected
- TTL-compatible inputs and outputs
- Easy memory expansion with \overline{CE} and \overline{OE} features

Functional Description^[1]

The CY7C1041CV33 is a high-performance CMOS Static RAM organized as 262,144 words by 16 bits.

Writing to the device is accomplished by taking Chip Enable (\overline{CE}) and Write Enable (\overline{WE}) inputs LOW. If Byte LOW Enable (\overline{BLE}) is LOW, then data from I/O pins (I/O_0 – I/O_7), is written into the location specified on the address pins (A_0 – A_{17}). If Byte HIGH Enable (\overline{BHE}) is LOW, then data from I/O pins (I/O_8 – I/O_{15}) is written into the location specified on the address pins (A_0 – A_{17}).

Reading from the device is accomplished by taking Chip Enable (\overline{CE}) and Output Enable (\overline{OE}) LOW while forcing the Write Enable (\overline{WE}) HIGH. If Byte LOW Enable (\overline{BLE}) is LOW, then data from the memory location specified by the address pins will appear on I/O_0 – I/O_7 . If Byte HIGH Enable (\overline{BHE}) is LOW, then data from memory will appear on I/O_8 to I/O_{15} . See the truth table at the back of this data sheet for a complete description of Read and Write modes.

The input/output pins (I/O_0 – I/O_{15}) are placed in a high-impedance state when the device is deselected (\overline{CE} HIGH), the outputs are disabled (\overline{OE} HIGH), the \overline{BHE} and \overline{BLE} are disabled (\overline{BHE} , \overline{BLE} HIGH), or during a Write operation (\overline{CE} LOW, and \overline{WE} LOW).

The CY7C1041CV33 is available in a standard 44-pin 400-mil-wide body width SOJ and 44-pin TSOP II package with center power and ground (revolutionary) pinout, as well as a 48-ball fine-pitch ball grid array (FBGA) package.

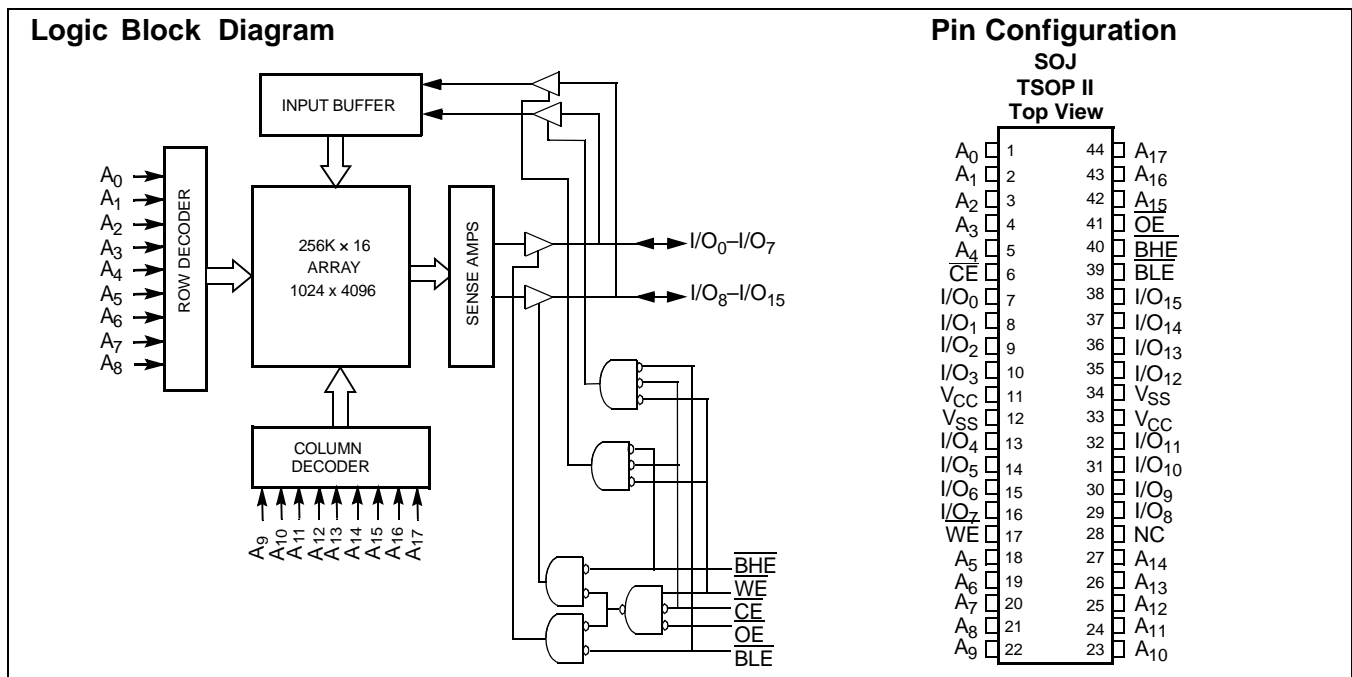

Notes:

1. For guidelines on SRAM system design, please refer to the "System Design Guidelines" Cypress application note, available on the internet at www.cypress.com.

Selection Guide

		-8	-10	-12	-15	-20	Unit
Maximum Access Time		8	10	12	15	20	ns
Maximum Operating Current	Commercial	100	90	85	80	75	mA
	Industrial	110	100	95	90	85	mA
	Automotive	-	-	-	-	90	mA
Maximum CMOS Standby Current	Commercial/ Industrial	10	10	10	10	10	mA
	Automotive	-	-	-	-	15	mA

Shaded areas contain advance information.

Pin Configurations

**48-ball Mini FBGA
(Top View)**

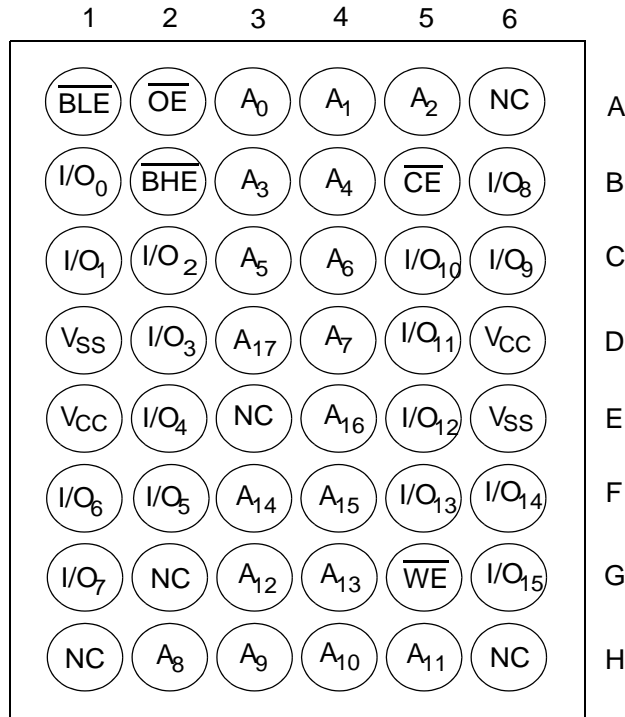

Pin Definitions

Pin Name	44-SOJ, 44-TSOP Pin Number	48-ball FBGA Pin Number	I/O Type	Description
A ₀ -A ₁₇	1-5,18-27, 42-44	A3,A4,A5,B3, B4,C3,C4,D4, H2,H3,H4,H5,G 3,G4,F3,F4,E4, D3	Input	Address Inputs used to select one of the address locations.
I/O ₀ - I/O ₁₅	7-10,13-16, 29-32,35-38	B1,C1,C2,D2,E 2,F2,F1,G1,B6, C6,C5,D5,E5, F5,F6,G6	Input/Output	Bidirectional Data I/O lines. Used as input or output lines depending on operation
NC ^[2]	28	A6,E3,G2,H1, H6	No Connect	No Connects. This pin is not connected to the die
WE	17	G5	Input/Control	Write Enable Input, active LOW. When selected LOW, a WRITE is conducted. When selected HIGH, a READ is conducted.
CE	6	B5	Input/Control	Chip Enable Input, active LOW. When LOW, selects the chip. When HIGH, deselects the chip.
BHE, BLE	39,40	A1,B2	Input/Control	Byte Write Select Inputs, active LOW. BHE controls I/O ₇ -I/O ₀ , BLE controls I/O ₁₅ -I/O ₈ .
OE2	41	A2	Input/Control	Output Enable, active LOW. Controls the direction of the I/O pins. When LOW, the I/O pins are allowed to behave as outputs. When deasserted HIGH, I/O pins are three-stated, and act as input data pins.
V _{SS}	12,34	D1,E6	Ground	Ground for the device. Should be connected to ground of the system.
V _{CC}	11,33	D6,E1	Power Supply	Power Supply inputs to the device.

Notes:

2. NC pins are not connected on the die.

Maximum Ratings

(Above which the useful life may be impaired. For user guidelines, not tested.)

Storage Temperature -65°C to +150°C

Ambient Temperature with Power Applied -55°C to +125°C

Supply Voltage on V_{CC} to Relative GND^[3] -0.5V to +4.6V

DC Voltage Applied to Outputs in High-Z State^[3] -0.5V to V_{CC} + 0.5V

DC Input Voltage^[3] -0.5V to V_{CC} + 0.5V

Current into Outputs (LOW) 20 mA

Operating Range

Range	Ambient Temperature	V _{CC}
Commercial	0°C to +70°C	3.3V ± 0.3V
Industrial	-40°C to +85°C	
Automotive	-40°C to +125°C	

DC Electrical Characteristics Over the Operating Range

Parameter	Description	Test Conditions	-8		-10		-12		-15		-20		Unit		
			Min.	Max.	Min.	Max.	Min.	Max.	Min.	Max.	Min.	Max.			
V _{OH}	Output HIGH Voltage	V _{CC} = Min., I _{OH} = -4.0 mA	2.4		2.4		2.4		2.4		2.4		V		
V _{OL}	Output LOW Voltage	V _{CC} = Min., I _{OL} = 8.0 mA		0.4		0.4		0.4		0.4		0.4	V		
V _{IH}	Input HIGH Voltage		2.0	V _{CC} + 0.3	2.0	V _{CC} + 0.3	2.0	V _{CC} + 0.3	2.0	V _{CC} + 0.3	2.0	V _{CC} + 0.3	V		
V _{IL} ^[3]	Input LOW Voltage		-0.3	0.8	-0.3	0.8	-0.3	0.8	-0.3	0.8	-0.3	0.8	V		
I _{IX}	Input Load Current	GND ≤ V _I ≤ V _{CC}	Com'l / Ind'l		-1	+1	-1	+1	-1	+1	-1	+1	+1	μA	
			Automotive		-	-	-	-	-	-	-	-	-20	+20	μA
I _{OZ}	Output Leakage Current	GND ≤ V _{OUT} ≤ V _{CC} , Output Disabled	Com'l / Ind'l		-1	+1	-1	+1	-1	+1	-1	+1	+1	μA	
			Automotive		-	-	-	-	-	-	-	-	-20	+20	μA
I _{CC}	V _{CC} Operating Supply Current	V _{CC} = Max., f = f _{MAX} = 1/t _{RC}	Comm'l			100		90		85		80	75	mA	
			Ind'l			110		100		95		90		85	mA
			Automotive			-		-		-		-		-	90
I _{SB1}	Automatic CE Power-down Current —TTL Inputs	Max. V _{CC} , CE ≥ V _{IH} , V _{IN} ≥ V _{IH} or V _{IN} ≤ V _{IL} , f = f _{MAX}	Com'l / Ind'l			40		40		40		40	40	mA	
			Automotive			-		-		-		-		45	mA
I _{SB2}	Automatic CE Power-down Current —CMOS Inputs	Max. V _{CC} , CE ≥ V _{CC} - 0.3V, V _{IN} ≥ V _{CC} - 0.3V, or V _{IN} ≤ 0.3V, f = 0	Com'l / Ind'l			10		10		10		10	10	mA	
			Automotive			-		-		-		-		15	mA

Shaded areas contain advance information.

Capacitance^[4]

Parameter	Description	Test Conditions	Max.	Unit
C _{IN}	Input Capacitance	T _A = 25°C, f = 1 MHz, V _{CC} = 3.3V	8	pF
C _{OUT}	I/O Capacitance		8	pF

Thermal Resistance^[4]

Parameter	Description	Test Conditions	44-pin TSOP-II (Non Pb-Free)	48-FBGA (Non Pb-Free)	Unit
Θ _{JA}	Thermal Resistance (Junction to Ambient)	Test conditions follow standard test methods and procedures for measuring thermal impedance, per EIA / JESD51.	76.85	92.78	°C/W
Θ _{JC}	Thermal Resistance (Junction to Case)		11.26	8.88	°C/W

Notes:

- V_{IL} (min.) = -2.0V and V_{IH} (max) = V_{CC} + 0.5V for pulse durations of less than 20 ns.
- Tested initially and after any design or process changes that may affect these parameters.



AC Switching Characteristics^[5] Over the Operating Range

Parameter	Description	-8		-10		-12		-15		-20		Unit
		Min.	Max.	Min.	Max.	Min.	Max.	Min.	Max.	Min.	Max.	
Read Cycle												
$t_{power}^{[6]}$	V_{CC} (typical) to the first access	1		1		1		1		1		μs
t_{RC}	Read Cycle Time	8		10		12		15		20		ns
t_{AA}	Address to Data Valid		8		10		12		15		20	ns
t_{OHA}	Data Hold from Address Change	3		3		3		3		3		ns
t_{ACE}	CE LOW to Data Valid		8		10		12		15		20	ns
t_{DOE}	OE LOW to Data Valid		4		5		6		7		8	ns
t_{LZOE}	OE LOW to Low-Z	0		0		0		0		0		ns
t_{HZOE}	OE HIGH to High-Z ^[7, 8]		4		5		6		7		8	ns
t_{LZCE}	CE LOW to Low-Z ^[8]	3		3		3		3		3		ns
t_{HZCE}	CE HIGH to High-Z ^[7, 8]		4		5		6		7		8	ns
t_{PU}	CE LOW to Power-Up	0		0		0		0		0		ns
t_{PD}	CE HIGH to Power-Down		8		10		12		15		20	ns
t_{DBE}	Byte Enable to Data Valid		4		5		6		7		8	ns
t_{LZBE}	Byte Enable to Low-Z	0		0		0		0		0		ns
t_{HZBE}	Byte Disable to High-Z		6		6		6		7		8	ns
Write Cycle^[9, 10]												
t_{WC}	Write Cycle Time	8		10		12		15		20		ns
t_{SCE}	CE LOW to Write End	6		7		8		10		10		ns
t_{AW}	Address Set-Up to Write End	6		7		8		10		10		ns
t_{HA}	Address Hold from Write End	0		0		0		0		0		ns
t_{SA}	Address Set-Up to Write Start	0		0		0		0		0		ns
t_{PWE}	WE Pulse Width	6		7		8		10		10		ns
t_{SD}	Data Set-Up to Write End	4		5		6		7		8		ns
t_{HD}	Data Hold from Write End	0		0		0		0		0		ns
t_{LZWE}	WE HIGH to Low-Z ^[8]	3		3		3		3		3		ns
t_{HZWE}	WE LOW to High-Z ^[7, 8]		4		5		6		7		8	ns
t_{BW}	Byte Enable to End of Write	6		7		8		10		10		ns

Shaded areas contain advance information.

Notes:

5. Test conditions assume signal transition time of 3 ns or less, timing reference levels of 1.5V, input pulse levels of 0 to 3.0V.
6. t_{POWER} gives the minimum amount of time that the power supply should be at typical V_{CC} values until the first memory access can be performed.
7. t_{HZOE} , t_{HZCE} , and t_{HZWE} are specified with a load capacitance of 5 pF as in part (d) of AC Test Loads. Transition is measured ± 500 mV from steady-state voltage.
8. At any given temperature and voltage condition, t_{HZCE} is less than t_{LZCE} , t_{HZOE} is less than t_{LZOE} , and t_{HZWE} is less than t_{LZWE} for any given device.
9. The internal Write time of the memory is defined by the overlap of CE LOW, and WE LOW. CE and WE must be LOW to initiate a Write, and the transition of either of these signals can terminate the Write. The input data set-up and hold timing should be referenced to the leading edge of the signal that terminates the Write.
10. The minimum Write cycle time for Write Cycle No. 3 (\overline{WE} controlled, \overline{OE} LOW) is the sum of t_{HZWE} and t_{SD} .

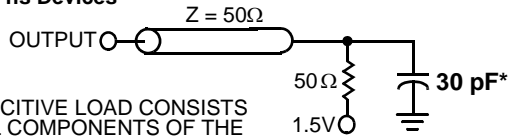
AC Test Loads and Waveforms^[11]
8-, 10-ns Devices

* CAPACITIVE LOAD CONSISTS OF ALL COMPONENTS OF THE TEST ENVIRONMENT

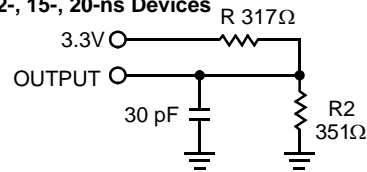
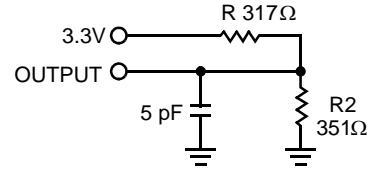
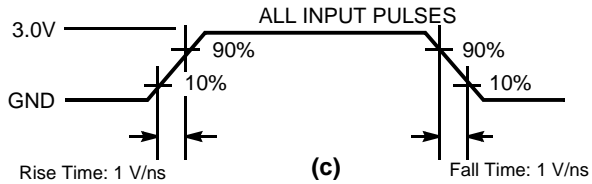
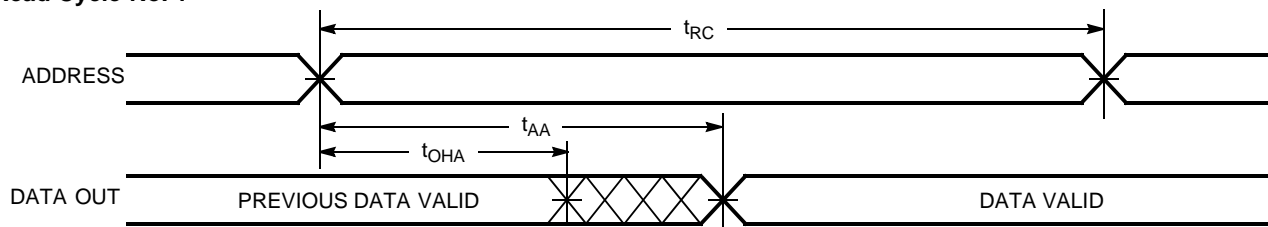
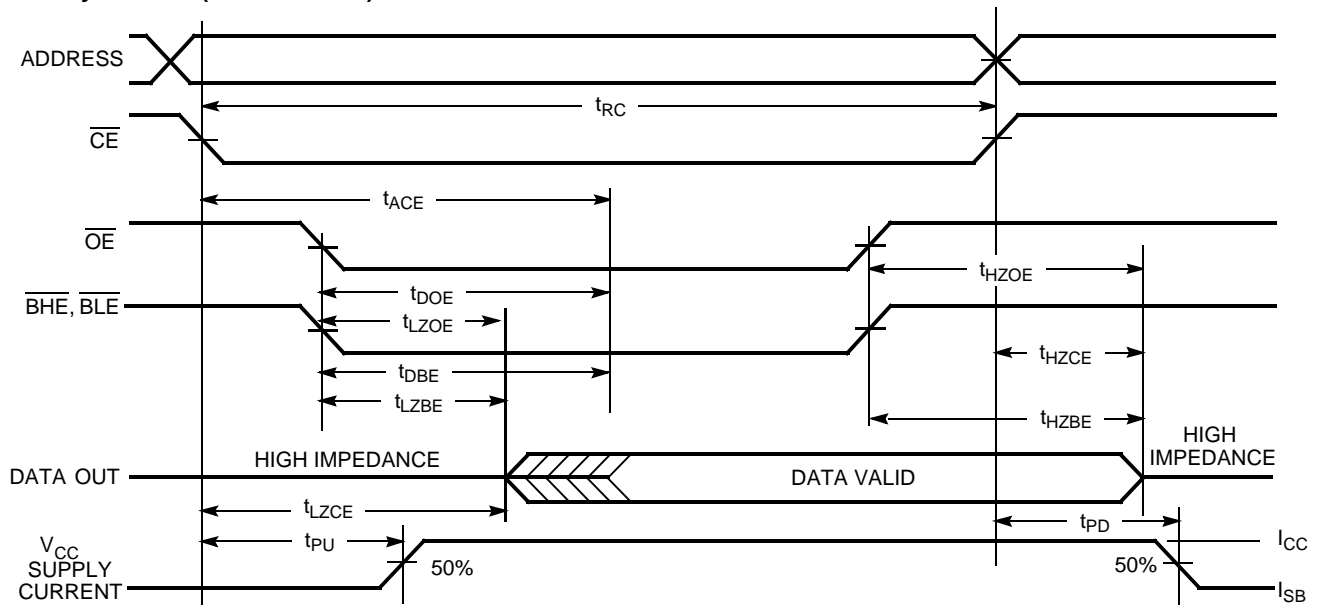
(a)
12-, 15-, 20-ns Devices

(b)
High-Z Characteristics

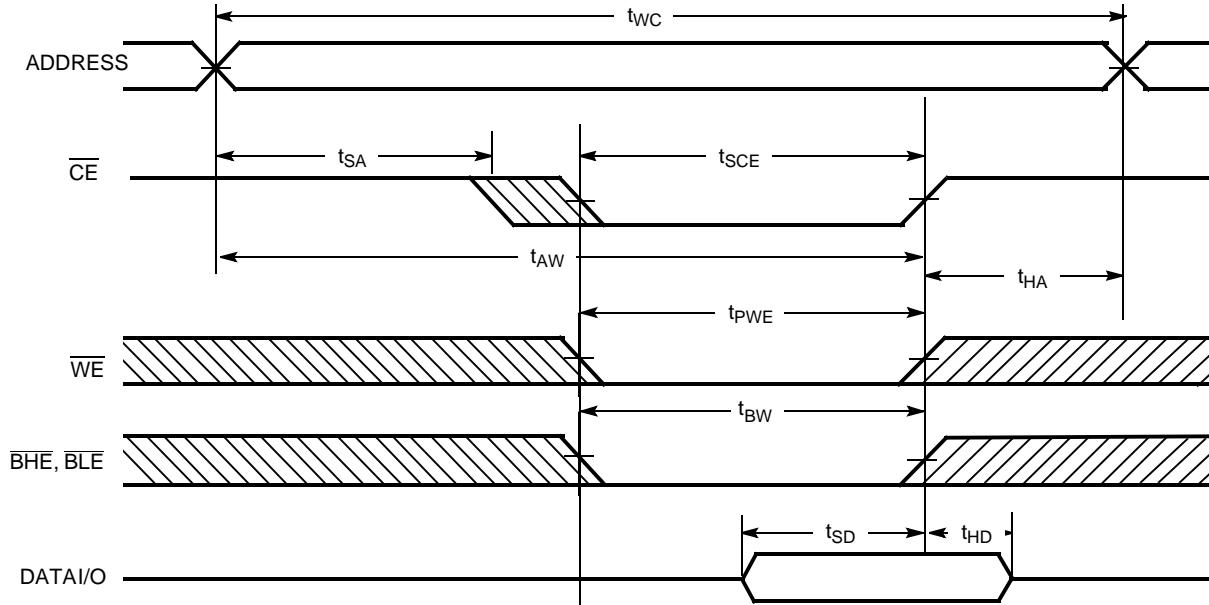
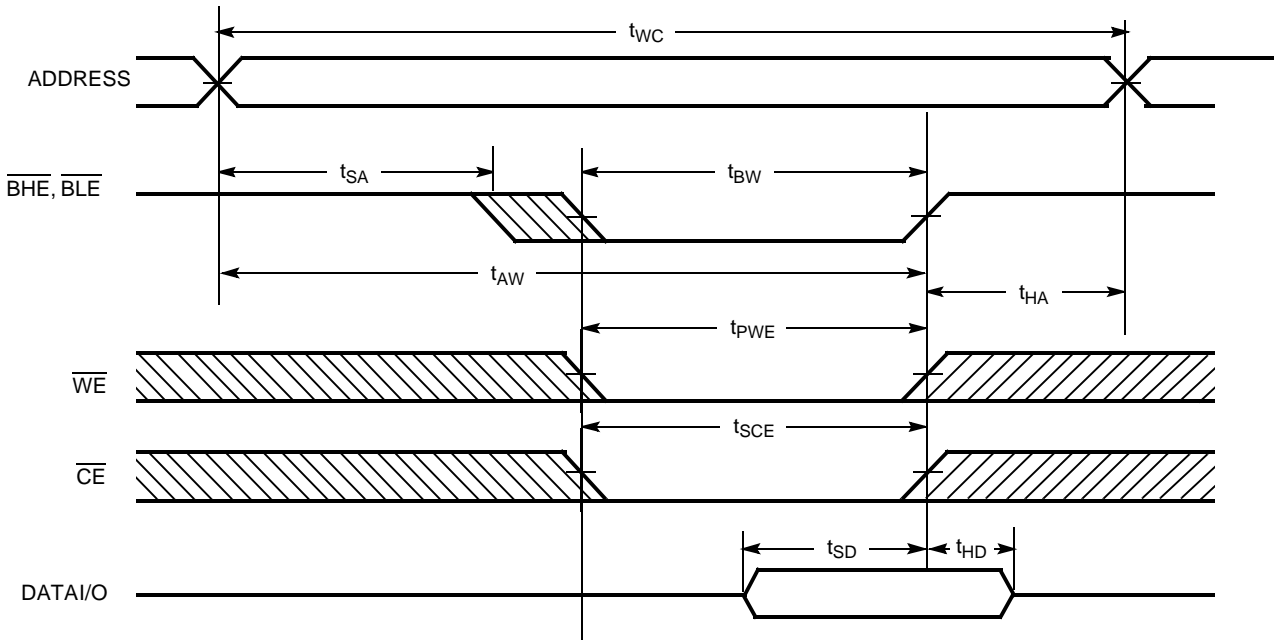
(d)

(c)
Switching Waveforms
Read Cycle No. 1^[12, 13]

Read Cycle No. 2 (OE Controlled)^[13, 14]

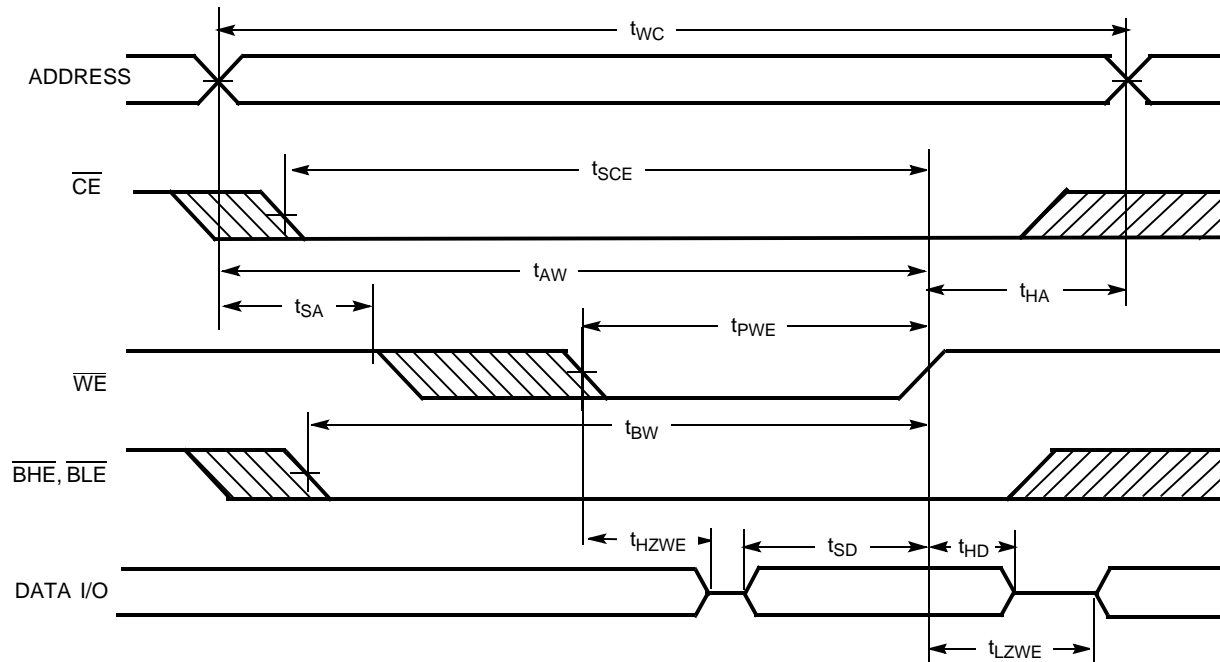
Notes:

11. AC characteristics (except High-Z) for all 8-ns and 10-ns parts are tested using the load conditions shown in Figure (a). All other speeds are tested using the Thevenin load shown in Figure (b). High-Z characteristics are tested for all speeds using the test load shown in Figure (d).
12. Device is continuously selected. OE, CE, BHE and/or BHE = V_{IL} .
13. WE is HIGH for Read cycle.
14. Address valid prior to or coincident with \overline{CE} transition LOW.

Switching Waveforms (continued)
Write Cycle No. 1 ($\overline{\text{CE}}$ Controlled)^[15, 16]

Write Cycle No. 2 ($\overline{\text{BLE}}$ or $\overline{\text{BHE}}$ Controlled)

Notes:

15. Data I/O is high-impedance if $\overline{\text{OE}}$ or $\overline{\text{BHE}}$ and/or $\overline{\text{BLE}} = V_{\text{IH}}$.
16. If $\overline{\text{CE}}$ goes HIGH simultaneously with $\overline{\text{WE}}$ going HIGH, the output remains in a high-impedance state.

Switching Waveforms (continued)

Write Cycle No.3 (\overline{WE} Controlled, \overline{OE} LOW)

Truth Table

CE	OE	WE	BLE	BHE	I/O ₀ -I/O ₇	I/O ₈ -I/O ₁₅	Mode	Power
H	X	X	X	X	High-Z	High-Z	Power-down	Standby (I_{SB})
L	L	H	L	L	Data Out	Data Out	Read All Bits	Active (I_{CC})
L	L	H	L	H	Data Out	High-Z	Read Lower Bits Only	Active (I_{CC})
L	L	H	H	L	High-Z	Data Out	Read Upper Bits Only	Active (I_{CC})
L	X	L	L	L	Data In	Data In	Write All Bits	Active (I_{CC})
L	X	L	L	H	Data In	High-Z	Write Lower Bits Only	Active (I_{CC})
L	X	L	H	L	High-Z	Data In	Write Upper Bits Only	Active (I_{CC})
L	H	H	X	X	High-Z	High-Z	Selected, Outputs Disabled	Active (I_{CC})

Ordering Information

CY7C1041CV33				
Speed (ns)	Ordering Code	Package Name	Package Type	Operating Range
10	CY7C1041CV33-10BAC	BA48B	48-ball Fine Pitch BGA	Commercial
	CY7C1041CV33-10VC	V34	44-lead (400-mil) Molded SOJ	
	CY7C1041CV33-10ZC	Z44	44-pin TSOP II Z44	
	CY7C1041CV33-10ZXC	Z44	Lead (Pb)-Free, 44-pin TSOP II Z44	
	CY7C1041CV33-10BAI	BA48B	48-ball Fine Pitch BGA	Industrial
	CY7C1041CV33-10VI	V34	44-lead (400-mil) Molded SOJ	
	CY7C1041CV33-10ZI	Z44	44-pin TSOP II Z44	
	CY7C1041CV33-10ZXI	Z44	Lead (Pb)-Free, 44-pin TSOP II Z44	
12	CY7C1041CV33-12BAC	BA48B	48-ball Fine Pitch BGA	Commercial
	CY7C1041CV33-12VC	V34	44-lead (400-mil) Molded SOJ	
	CY7C1041CV33-12ZC	Z44	44-pin TSOP II Z44	
	CY7C1041CV33-12ZXC	Z44	Lead (Pb)-Free, 44-pin TSOP II Z44	
	CY7C1041CV33-12BAI	BA48B	48-ball Fine Pitch BGA	Industrial
	CY7C1041CV33-12VI	V34	44-lead (400-mil) Molded SOJ	
	CY7C1041CV33-12ZI	Z44	44-pin TSOP II Z44	
	CY7C1041CV33-12ZXI	Z44	Lead (Pb)-Free, 44-pin TSOP II Z44	
15	CY7C1041CV33-15BAC	BA48B	48-ball Fine Pitch BGA	Commercial
	CY7C1041CV33-15VC	V34	44-lead (400-mil) Molded SOJ	
	CY7C1041CV33-15ZC	Z44	44-pin TSOP II Z44	
	CY7C1041CV33-15ZXC	Z44	Lead (Pb)-Free, 44-pin TSOP II Z44	
	CY7C1041CV33-15BAI	BA48B	48-ball Fine Pitch BGA	Industrial
	CY7C1041CV33-15VI	V34	44-lead (400-mil) Molded SOJ	
	CY7C1041CV33-15ZI	Z44	44-pin TSOP II Z44	
	CY7C1041CV33-15ZXI	Z44	Lead (Pb)-Free, 44-pin TSOP II Z44	
20	CY7C1041CV33-20BAC	BA48B	48-ball Fine Pitch BGA	Commercial
	CY7C1041CV33-20VC	V34	44-lead (400-mil) Molded SOJ	
	CY7C1041CV33-20ZC	Z44	44-pin TSOP II Z44	
	CY7C1041CV33-20BAI	BA48B	48-ball Fine Pitch BGA	Industrial
	CY7C1041CV33-20VI	V34	44-lead (400-mil) Molded SOJ	
	CY7C1041CV33-20ZI	Z44	44-pin TSOP II Z44	
	CY7C1041CV33-20BAE	BA48B	48-ball Fine Pitch BGA	Automotive
	CY7C1041CV33-20VE	V34	44-lead (400-mil) Molded SOJ	
CY7C1041CV33-20ZE	Z44	44-pin TSOP II Z44		

Package Diagrams

48-ball (7.00 mm x 8.5 mm x 1.2 mm) FBGA BA48B

TOP VIEW

BOTTOM VIEW

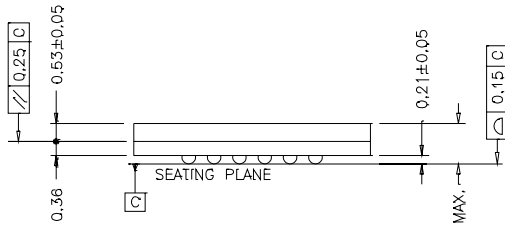
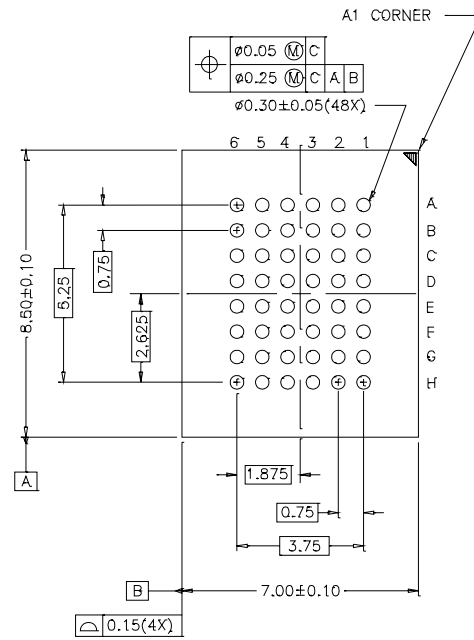
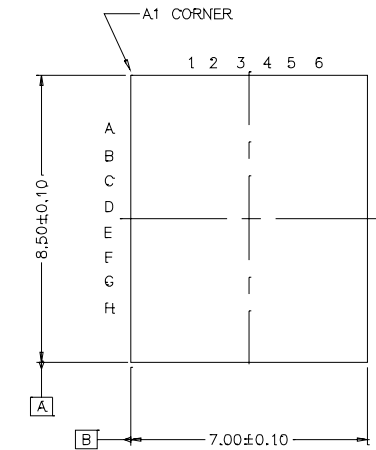

44-lead (400-mil) Molded SOJ V34

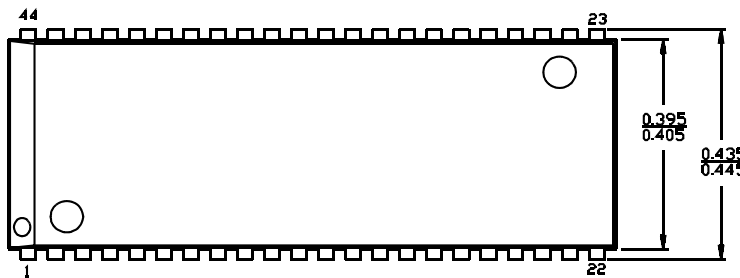

DIMENSIONS IN INCHES MIN. MAX.

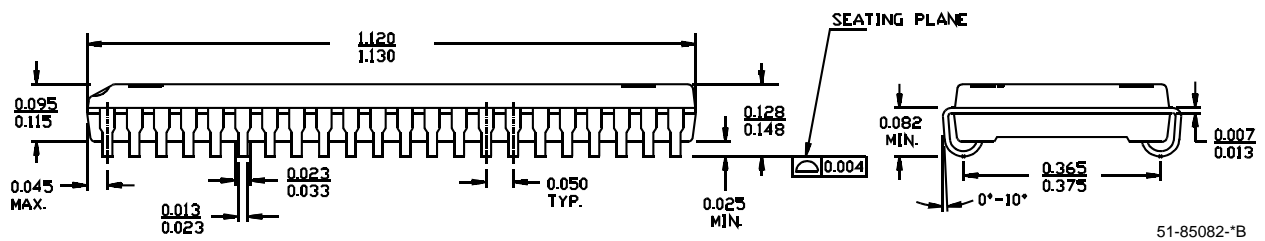

51-85082-B

Package Diagrams (continued)

44-pin TSOP II Z44

DIMENSION IN MM (INCH)
MAX
MIN

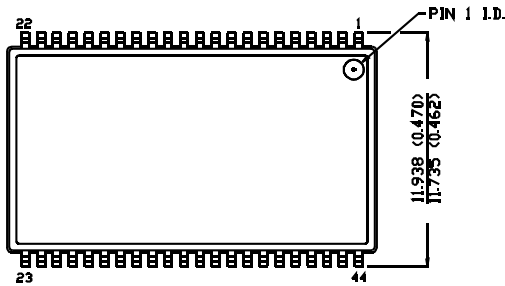

TOP VIEW

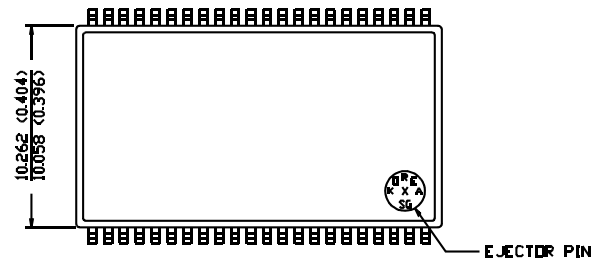

BOTTOM VIEW

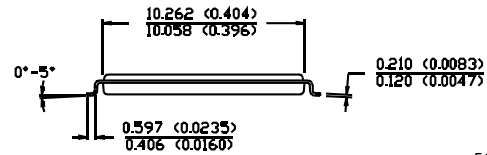
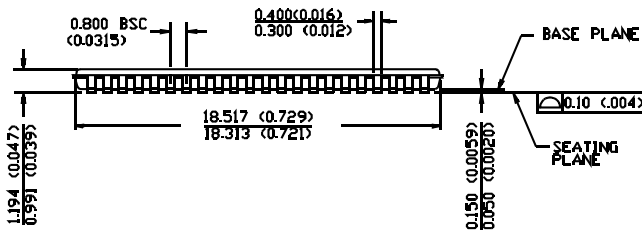

51-85087-A

All products and company names mentioned in this document may be the trademarks of their respective holders.

Document History Page

Document Title: CY7C1041CV33 4-Mbit (256K x 16) Static RAM				
Document Number: 38-05134				
REV.	ECN NO.	Issue Date	Orig. of Change	Description of Change
**	109513	12/13/01	HGK	New Data Sheet
*A	112440	12/20/01	BSS	Updated 51-85106 from revision *A to *C
*B	112859	03/25/02	DFP	Added CY7C1042CV33 in BGA package Removed 1042 BGA option pin ACC Final Data Sheet
*C	116477	09/16/02	CEA	Add applications foot note to data sheet
*D	119797	10/21/02	DFP	Added 20-ns speed bin
*E	262949	See ECN	RKF	1) Added Lead (Pb)-Free parts in the Ordering info (Page #9) 2) Added Automotive Specs to Datasheet



LittleDiode supplies new, hard to find or obsolete electronic components and semiconductors all over the world.

With over two million different components listed you are sure to find the part you need.

Feel free to visit us today at our online store:

LittleDiode.com

Looking forward to providing you with the best possible service.