

Selection Guide

		-8 ^U	-10	-12	-15	Unit
Maximum Access Time		8	10	12	15	ns
Maximum Operating Current	Commercial	100	90	85	80	mA
	Industrial	110	100	95	90	mA
	Automotive	-	-	-	95	mA
Maximum CMOS Standby Current	Commercial / Industrial	10	10	10	10	mA
	Automotive	-	-	-	15	mA

Shaded areas contain advance information.

Pin Definitions

Pin Name	36-SOJ Pin Number	44 TSOP-II Pin Number	I/O Type	Description
A ₀ -A ₁₈	1-5,14-18, 20-24,32-35	3-7,16-20, 26-30,38-41	Input	Address Inputs used to select one of the address locations.
I/O ₀ - I/O ₇	7,8,11,12,25, 26,29,30	9,10,13,14, 31,32,35,36	Input/Output	Bidirectional Data I/O lines. Used as input or output lines depending on operation
NC ^[2]	19,36	1,2,21,22,23, 24,25,42,43, 44	No Connect	No Connects. This pin is not connected to the die
WE	13	15	Input/Control	Write Enable Input, active LOW. When selected LOW, a WRITE is conducted. When selected HIGH, a READ is conducted.
CE	6	8	Input/Control	Chip Enable Input, active LOW. When LOW, selects the chip. When HIGH, deselects the chip.
OE	31	37	Input/Control	Output Enable, active LOW. Controls the direction of the I/O pins. When LOW, the I/O pins are allowed to behave as outputs. When deasserted HIGH, I/O pins are three-stated, and act as input data pins.
V _{SS} , GND	10,28	12,34	Ground	Ground for the device. Should be connected to ground of the system.
V _{CC}	9,27	11,33	Power Supply	Power Supply inputs to the device.

Notes:

- NC pins are not connected on the die.

Maximum Ratings

(Above which the useful life may be impaired. For user guidelines, not tested.)

Storage Temperature -65°C to +150°C
 Ambient Temperature with
 Power Applied..... -55°C to +125°C
 Supply Voltage on V_{CC} to Relative GND^[3] -0.5V to +4.6V

DC Voltage Applied to Outputs

in High-Z State^[3] -0.5V to $V_{CC} + 0.5V$

DC Input Voltage^[3] -0.5V to $V_{CC} + 0.5V$

Current into Outputs (LOW)..... 20 mA

Operating Range

Range	Ambient Temperature	V_{CC}
Commercial	0°C to +70°C	3.3V ± 0.3V
Industrial	-40°C to +85°C	
Automotive	-40°C to +125°C	

Electrical Characteristics Over the Operating Range

Parameter	Description	Test Conditions	-8 ^{II}		-10		-12		-15		Unit		
			Min.	Max.	Min.	Max.	Min.	Max.	Min.	Max.			
V_{OH}	Output HIGH Voltage	$V_{CC} = \text{Min.}; I_{OH} = -4.0 \text{ mA}$	2.4		2.4		2.4		2.4		V		
V_{OL}	Output LOW Voltage	$V_{CC} = \text{Min.}; I_{OL} = 8.0 \text{ mA}$		0.4		0.4		0.4		0.4	V		
V_{IH}	Input HIGH Voltage		2.0	$V_{CC} + 0.3$	2.0	$V_{CC} + 0.3$	2.0	$V_{CC} + 0.3$	2.0	$V_{CC} + 0.3$	V		
V_{IL}	Input LOW Voltage ^[3]		-0.3	0.8	-0.3	0.8	-0.3	0.8	-0.3	0.8	V		
I_{IX}	Input Load Current	$GND \leq V_I \leq V_{CC}$	Com'l / Ind'l		-1	+1	-1	+1	-1	+1	-1	+1	μA
			Automotive		-	-	-	-	-	-	-20	+20	μA
I_{OZ}	Output Leakage Current	$GND \leq V_{OUT} \leq V_{CC}$, Output Disabled	Com'l / Ind'l		-1	+1	-1	+1	-1	+1	-1	+1	μA
			Automotive		-	-	-	-	-	-	-20	+20	μA
I_{CC}	V_{CC} Operating Supply Current	$V_{CC} = \text{Max.}, f = f_{MAX} = 1/t_{RC}$	Com'l			100		90		85		80	mA
			Ind'l			110		100		95		90	mA
			Automotive			-		-		-		95	mA
I_{SB1}	Automatic CE Power-down Current —TTL Inputs	Max. V_{CC} , $CE \geq V_{IH}$; $V_{IN} \geq V_{IH}$ or $V_{IN} \leq V_{IL}$, $f = f_{MAX}$	Com'l / Ind'l			40		40		40		40	mA
			Automotive			-		-		-		45	mA
I_{SB2}	Automatic CE Power-down Current —CMOS Inputs	Max. V_{CC} , $CE \geq V_{CC} - 0.3V$, $V_{IN} \geq V_{CC} - 0.3V$, or $V_{IN} \leq 0.3V$, $f = 0$	Com'l/Ind'l			10		10		10		10	mA
			Automotive			-		-		-		15	mA

Capacitance^[4]

Parameter	Description	Test Conditions	Max.	Unit
C_{IN}	Input Capacitance	$T_A = 25^\circ\text{C}, f = 1 \text{ MHz}, V_{CC} = 3.3V$	8	pF
C_{OUT}	I/O Capacitance		8	pF

Thermal Resistance^[4]

Parameter	Description	Test Conditions	36-pin SOJ (Non Pb-Free)	36-pin SOJ (Pb-Free)	44-TSOP-II (Non Pb-Free)	44-TSOP-II (Pb-Free)	Unit
Θ_{JA}	Thermal Resistance (Junction to Ambient)	Test conditions follow standard test methods and procedures for measuring thermal impedance, per EIA / JESD51.	46.51	46.51	41.66	41.66	$^\circ\text{C/W}$
Θ_{JC}	Thermal Resistance (Junction to Case)		18.8	18.8	10.56	10.56	$^\circ\text{C/W}$

Notes:

- $V_{IL}(\text{min.}) = -2.0V$ and $V_{IH}(\text{max.}) = V_{CC} + 0.5V$ for pulse durations of less than 20 ns.
- Tested initially and after any design or process changes that may affect these parameters.

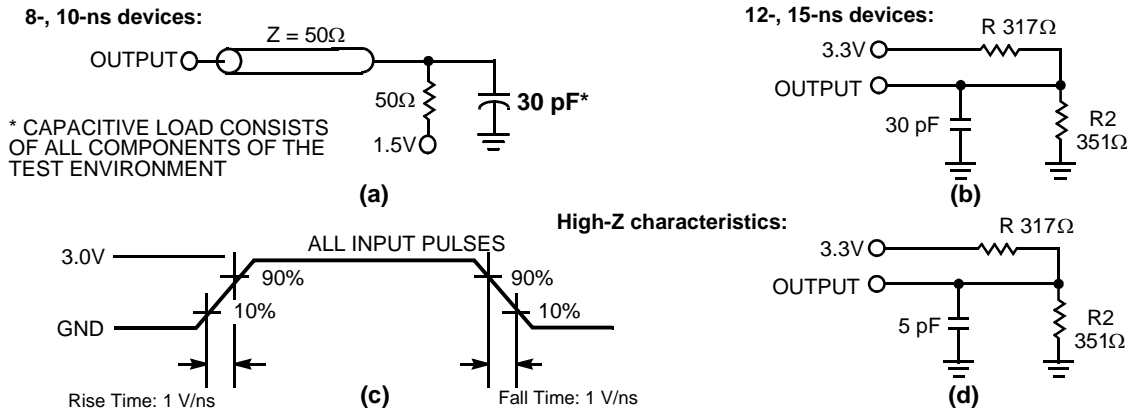
AC Test Loads and Waveforms^[5]

AC Switching Characteristics^[6] Over the Operating Range

Parameter	Description	-8 ^[1]		-10		-12		-15		Unit
		Min.	Max.	Min.	Max.	Min.	Max.	Min.	Max.	
Read Cycle										
$t_{power}^{[7]}$	V_{CC} (typical) to the first access	1		1		1		1		μs
t_{RC}	Read Cycle Time	8		10		12		15		ns
t_{AA}	Address to Data Valid		8		10		12		15	ns
t_{OHA}	Data Hold from Address Change	3		3		3		3		ns
t_{ACE}	CE LOW to Data Valid		8		10		12		15	ns
t_{DOE}	OE LOW to Data Valid		4		5		6		7	ns
t_{LZOE}	OE LOW to Low-Z	0		0		0		0		ns
t_{HZOE}	OE HIGH to High-Z ^[8, 9]		4		5		6		7	ns
t_{LZCE}	CE LOW to Low-Z ^[9]	3		3		3		3		ns
t_{HZCE}	CE HIGH to High-Z ^[8, 9]		4		5		6		7	ns
t_{PU}	CE LOW to Power-up	0		0		0		0		ns
t_{PD}	CE HIGH to Power-down		8		10		12		15	ns
Write Cycle^[10, 11]										
t_{WC}	Write Cycle Time	8		10		12		15		ns
t_{SCE}	CE LOW to Write End	6		7		8		10		ns
t_{AW}	Address Set-up to Write End	6		7		8		10		ns
t_{HA}	Address Hold from Write End	0		0		0		0		ns
t_{SA}	Address Set-up to Write Start	0		0		0		0		ns
t_{PWE}	WE Pulse Width	6		7		8		10		ns
t_{SD}	Data Set-up to Write End	4		5		6		7		ns
t_{HD}	Data Hold from Write End	0		0		0		0		ns
t_{LZWE}	WE HIGH to Low-Z ^[9]	3		3		3		3		ns
t_{HZWE}	WE LOW to High-Z ^[8, 9]		4		5		6		7	ns

Notes:

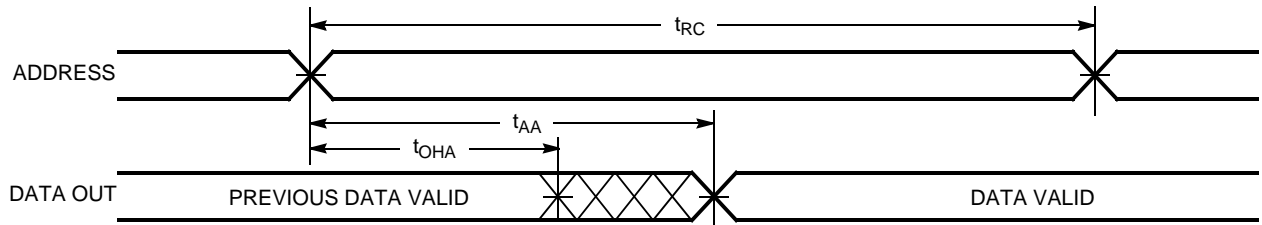
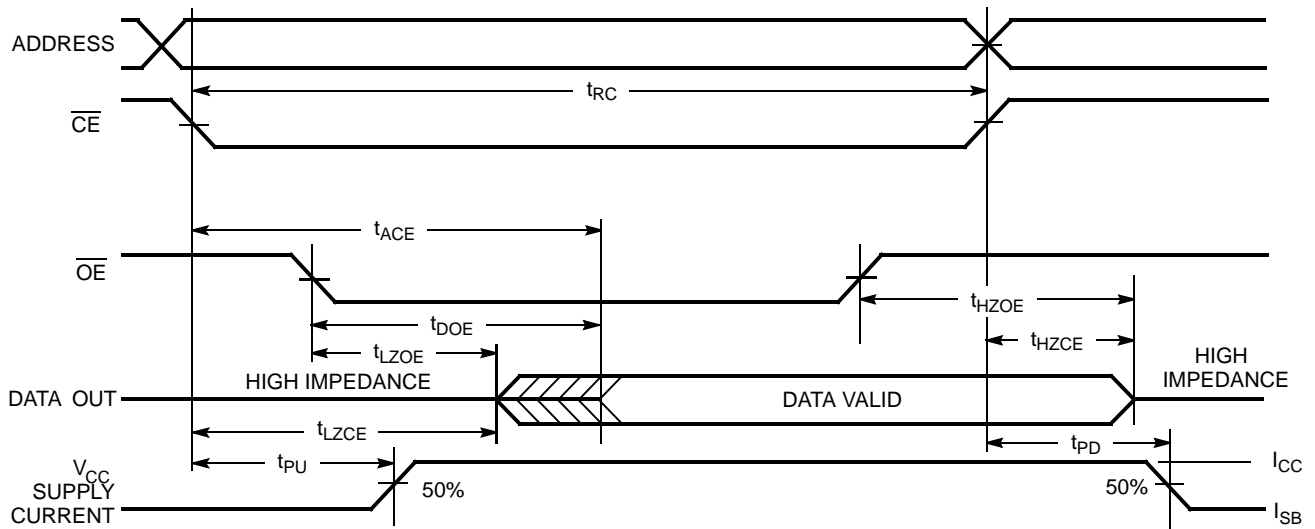
5. AC characteristics (except High-Z) for all 8-ns and 10-ns parts are tested using the load conditions shown in Figure (a). All other speeds are tested using the Thevenin load shown in Figure (b). High-Z characteristics are tested for all speeds using the test load shown in Figure (d).

Switching Waveforms
Read Cycle No. 1^[12, 13]

Read Cycle No. 2 (OE Controlled)^[13, 14]

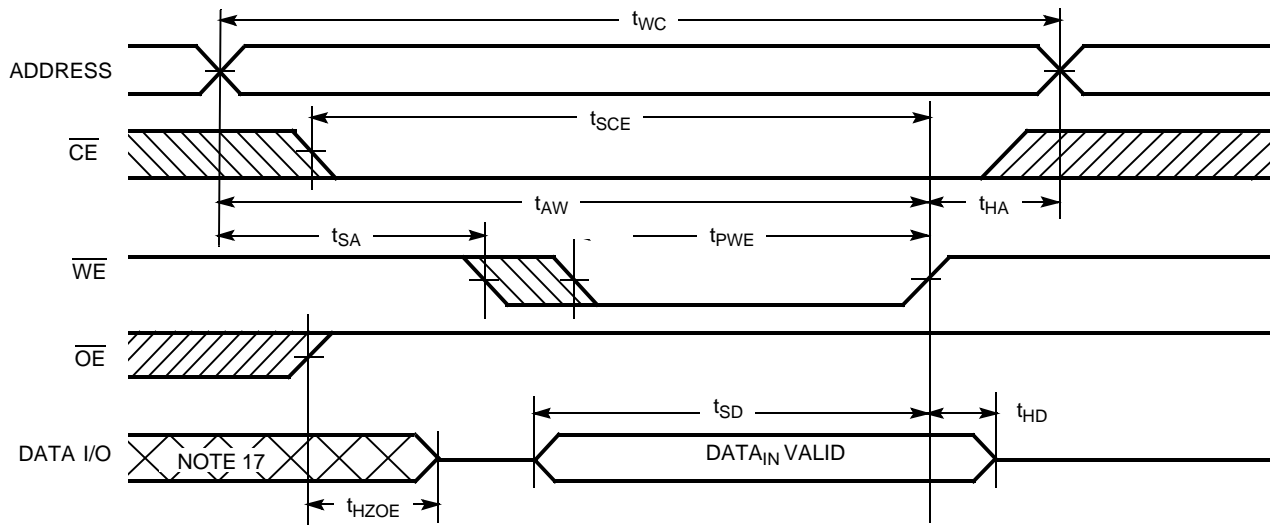
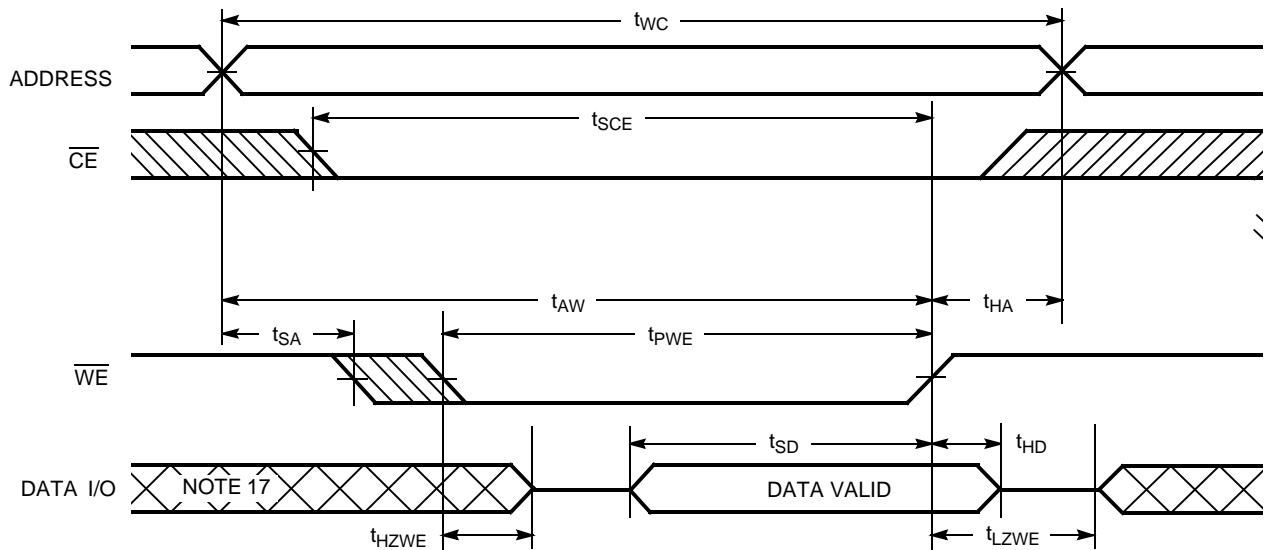
Notes:

6. Test conditions assume signal transition time of 3 ns or less, timing reference levels of 1.5V, input pulse levels of 0 to 3.0V.
7. t_{POWER} gives the minimum amount of time that the power supply should be at stable, typical V_{CC} values until the first memory access can be performed.
8. t_{HZOE} , t_{HZCE} , and t_{HZWE} are specified with a load capacitance of 5 pF as in part (d) of AC Test Loads. Transition is measured ± 500 mV from steady-state voltage.
9. At any given temperature and voltage condition, t_{HZCE} is less than t_{LZCE} , t_{HZOE} is less than t_{LZOE} , and t_{HZWE} is less than t_{LZWE} for any given device.
10. The internal Write time of the memory is defined by the overlap of \overline{CE} LOW, and \overline{WE} LOW. \overline{CE} and \overline{WE} must be LOW to initiate a Write, and the transition of either of these signals can terminate the Write. The input data set-up and hold timing should be referenced to the leading edge of the signal that terminates the Write.
11. The minimum Write cycle time for Write Cycle No. 3 (\overline{WE} controlled, \overline{OE} LOW) is the sum of t_{HZWE} and t_{SD} .
12. Device is continuously selected. \overline{OE} , $\overline{CE} = V_{IL}$.
13. \overline{WE} is HIGH for Read cycle.

Switching Waveforms (continued)
Write Cycle No. 1 (\overline{WE} Controlled, \overline{OE} HIGH During Write)^[15, 16]

Write Cycle No. 2 (\overline{WE} Controlled, \overline{OE} LOW)^[16]

Notes:

14. Address valid prior to or coincident with \overline{CE} transition LOW.
15. Data I/O is high-impedance if $\overline{OE} = V_{IH}$.
16. If \overline{CE} goes HIGH simultaneously with \overline{WE} going HIGH, the output remains in a high-impedance state.
17. During this period the I/Os are in the output state and input signals should not be applied.

Truth Table

CE	OE	WE	I/O ₀ -I/O ₇	Mode	Power
H	X	X	High-Z	Power-down	Standby (I _{SB})
L	L	H	Data Out	Read	Active (I _{CC})
L	X	L	Data In	Write	Active (I _{CC})
L	H	H	High-Z	Selected, Outputs Disabled	Active (I _{CC})

Ordering Information

Speed (ns)	Ordering Code	Package Name	Package Type	Operating Range
10	CY7C1049CV33-10VC	V36	36-lead (400-Mil) Molded SOJ	Commercial
	CY7C1049CV33-10ZC	Z44	44-pin TSOP II	
	CY7C1049CV33-10VI	V36	36-lead (400-Mil) Molded SOJ	Industrial
	CY7C1049CV33-10ZI	Z44	44-pin TSOP II	
12	CY7C1049CV33-12VC	V36	36-lead (400-Mil) Molded SOJ	Commercial
	CY7C1049CV33-12ZC	Z44	44-pin TSOP II	
	CY7C1049CV33-12VI	V36	36-lead (400-Mil) Molded SOJ	Industrial
	CY7C1049CV33-12ZI	Z44	44-pin TSOP II	
15	CY7C1049CV33-15VXC	V36	36-lead (400-Mil) Molded SOJ (Pb-Free)	Commercial
	CY7C1049CV33-15VC	V36	36-lead (400-Mil) Molded SOJ	
	CY7C1049CV33-15ZXC	Z44	44-pin TSOP II (Pb-Free)	
	CY7C1049CV33-15ZC	Z44	44-pin TSOP II	
	CY7C1049CV33-15VI	V36	36-lead (400-Mil) Molded SOJ	Industrial
	CY7C1049CV33-15ZI	Z44	44-pin TSOP II	
	CY7C1049CV33-15VE	V36	36-lead (400-Mil) Molded SOJ	Automotive
	CY7C1049CV33-15ZE	Z44	44-pin TSOP II	

Package Diagrams

36-Lead (400-Mil) Molded SOJ V36

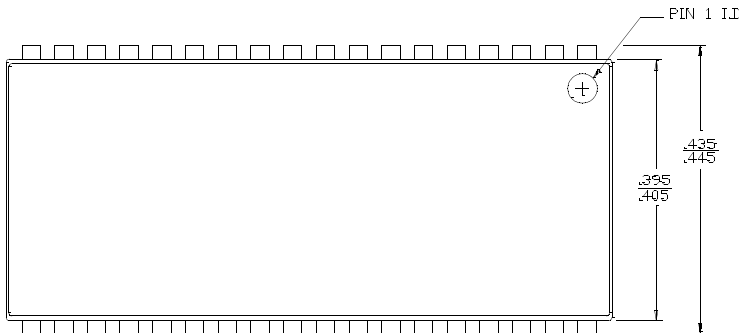

DIMENSIONS IN INCHES MIN. MAX.

DIM. A	
ANAM	CSPI
0.086	0.095
0.090	0.115

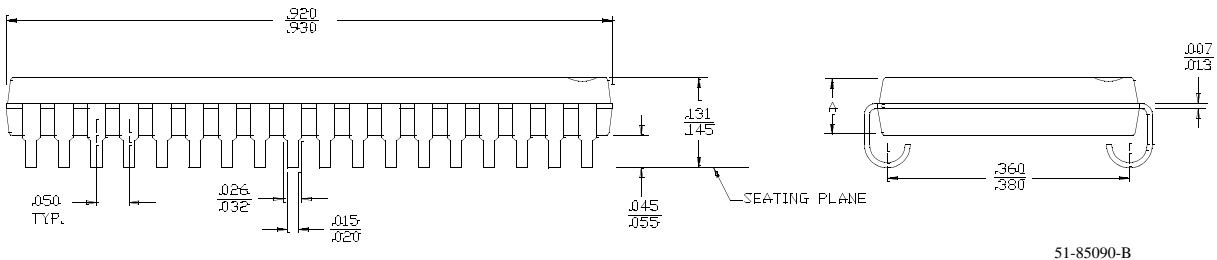

44-pin TSOP II Z44

DIMENSION IN MM (INCH)
MAX
MIN

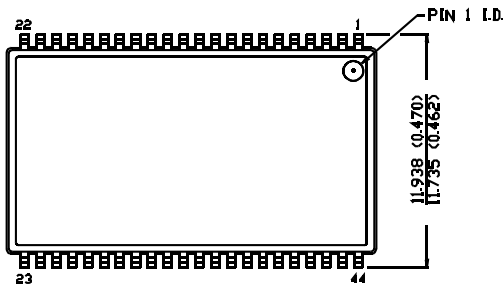

TOP VIEW

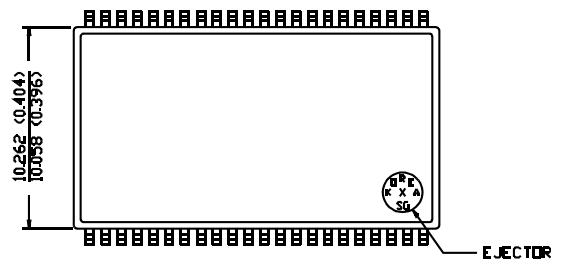

BOTTOM VIEW

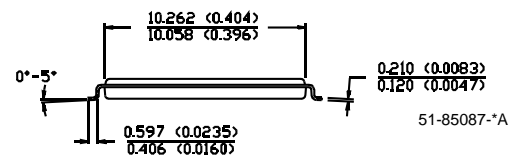
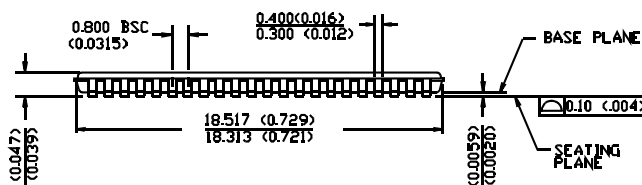

All products and company names mentioned in this document may be the trademarks of their respective holders.

Document History Page

Document Title: CY7C1049CV33 4-Mbit (512K x 8) Static RAM
Document Number: 38-05006

REV.	ECN NO.	Issue Date	Orig. of Change	Description of Change
**	112569	03/06/02	HGK	New Data Sheet
*A	114091	04/25/02	DFP	Changed Tpower unit from ns to μ s
*B	116479	09/16/02	CEA	Add applications foot note to data sheet, page 1.
*C	262949	See ECN	RKF	Added Automotive Specs to Datasheet Added Θ_{JA} and Θ_{JC} values on Page #3.



LittleDiode supplies new, hard to find or obsolete electronic components and semiconductors all over the world.

With over two million different components listed you are sure to find the part you need.

Feel free to visit us today at our online store:

LittleDiode.com

Looking forward to providing you with the best possible service.