



128K x 32 Synchronous-Pipelined RAM

Features

- Fast access times: 5 and 7 ns
- Fast clock speed: 100 and 66 MHz
- Provides high-performance 3-1-1-1 access rate
- Fast OE access times: 5 and 7 ns
- Optimal for performance (two-cycle chip deselect, depth expansion without wait state)
- Single +3.3V -5% and +10% power supply
- Supports +2.5V I/O
- 5V tolerant inputs except I/Os
- Clamp diodes to V_{SSQ} at all outputs
- Common data inputs and outputs
- Byte Write Enable and Global Write control
- Three chip enables for depth expansion and address pipeline
- Address, control, input, and output pipeline registers
- Internally self-timed Write Cycle
- Burst control pins (interleaved or linear burst sequence)
- Automatic power-down for portable applications
- High-density, high-speed packages
- Low-capacitive bus loading
- High 30-pF output drive capability at rated access time

Functional Description

The Cypress Synchronous Burst SRAM family employs high-speed, low-power CMOS designs using advanced triple-layer polysilicon, double-layer metal technology. Each memory cell consists of four transistors and two high valued resistors.

The CY7C1340A/GVT71128C32 SRAM integrates 131,072 x 32 SRAM cells with advanced synchronous peripheral circuitry and a two-bit counter for internal burst operation. All synchronous inputs are gated by registers controlled by a positive-edge-triggered Clock Input (CLK). The synchronous inputs include all addresses, all data inputs, address-pipelining chip enable (CE), depth-expansion Chip Enables (CE2 and CE2), Burst Control Inputs (ADSC, ADSP, and ADV), Write Enables (BW1, BW2, BW3, BW4, and BWE), and Global Write (GW).

Asynchronous inputs include the Output Enable (\overline{OE}) and Burst Mode Control (MODE). The data outputs (Q), enabled by OE, are also asynchronous.

Addresses and chip enables are registered with either Address Status Processor (ADSP) or Address Status Controller (ADSC) input pins. Subsequent burst addresses can be internally generated as controlled by the Burst Advance Pin (ADV).

Address, data inputs, and Write controls are registered on-chip to initiate self-timed Write cycle. Write cycles can be one to four bytes wide as controlled by the Write control inputs. Individual byte Write allows individual byte to be written. BW1 controls DQ1-DQ8. BW2 controls DQ9-DQ16. BW3 controls DQ17-DQ24. BW4 controls DQ25-DQ32. BW1, BW2, BW3, and BW4 can be active only with BWE being LOW. GW being LOW causes all bytes to be written. This device also incorporates pipelined enable circuit for easy depth expansion without penalizing system performance.

The CY7C1340A/GVT71128C32 operates from a +3.3V power supply. All inputs and outputs are TTL-compatible. The device is ideally suited for 486, Pentium®, 680 x 0, and PowerPC™ systems and for systems that benefit from a wide synchronous data bus.

Selection Guide

	7C1340A-100	7C1340A-66	Unit
Maximum Access Time	5	7	ns
Maximum Operating Current	225	120	mA
Maximum CMOS Standby Current	2	2	mA

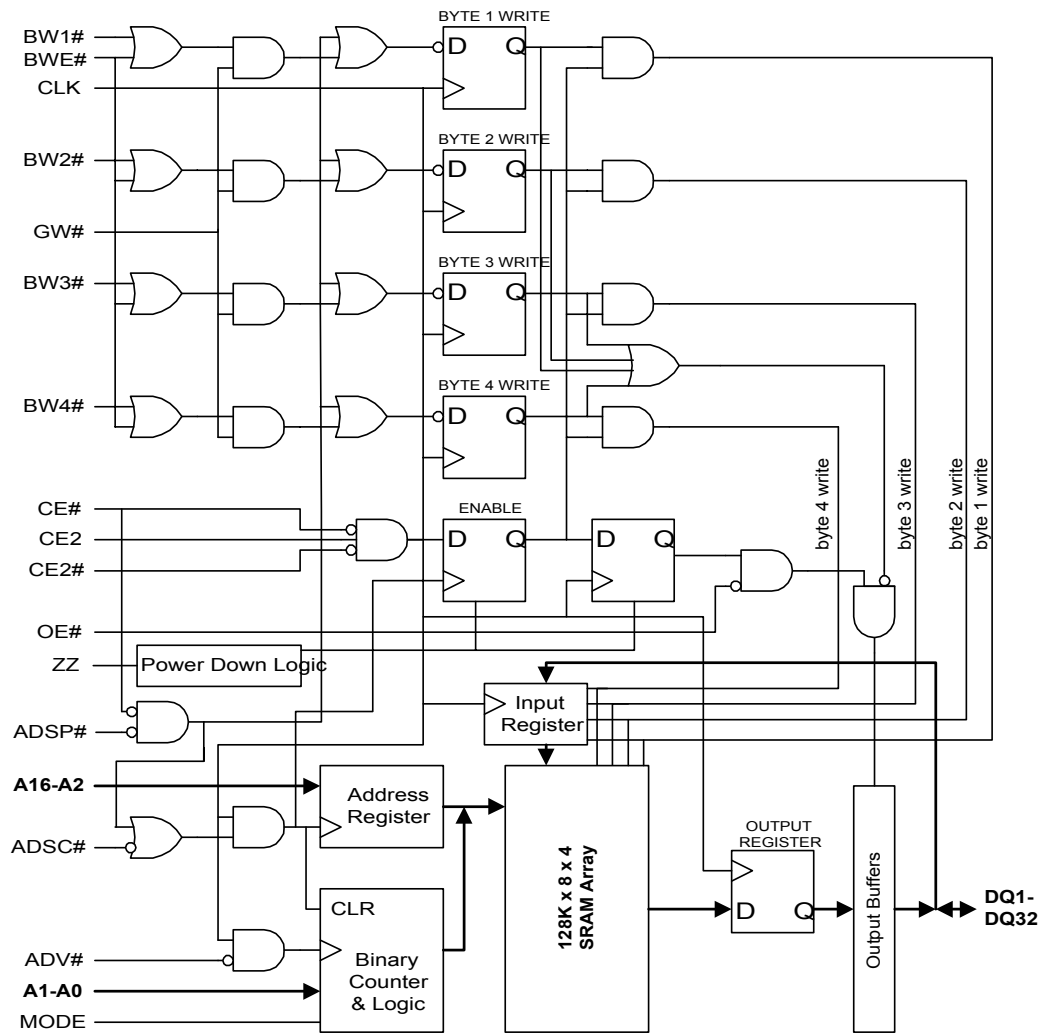
Functional Block Diagram^[1]

Note:

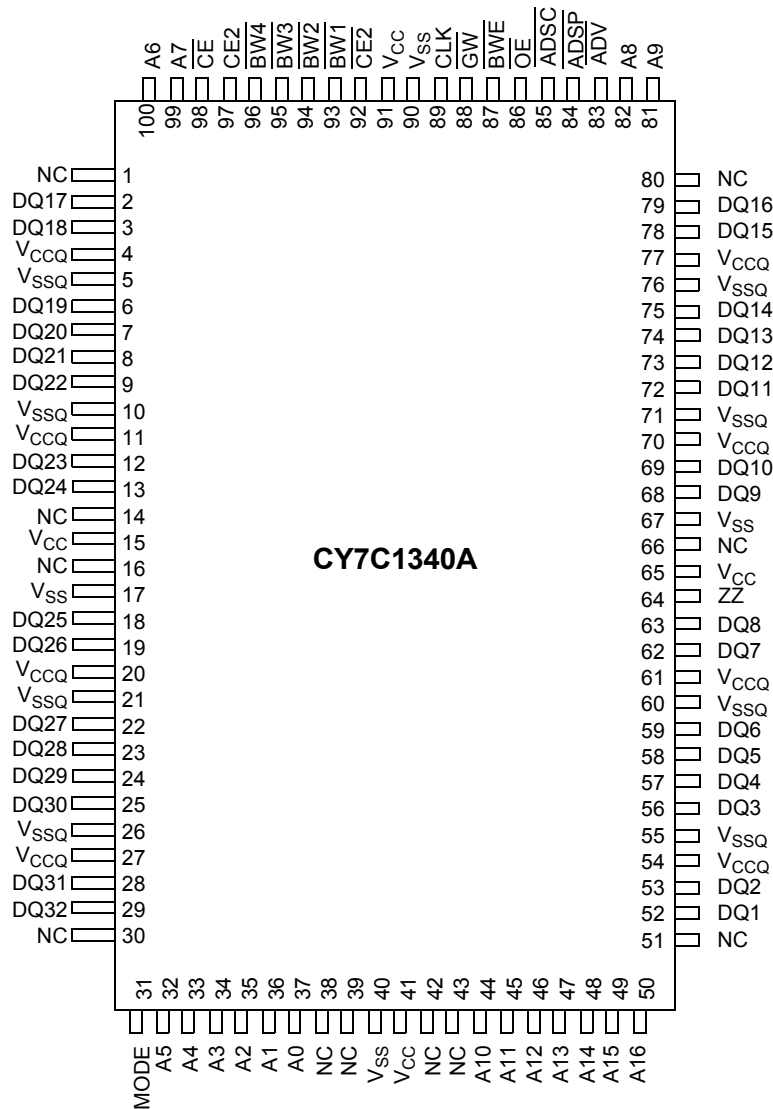
1. The functional block diagram illustrates simplified device operation. See Truth Table, pin descriptions and timing diagrams for detailed information.

Pin Configuration
**100-pin TQFP
Top View**

Pin Descriptions

Name	Type	Description
A0–A16	Input-Synchronous	Addresses: These inputs are registered and must meet the set-up and hold times around the rising edge of CLK. The burst counter generates internal addresses associated with A0 and A1, during burst cycle and wait cycle.
BW1, BW2, BW3, BW4	Input-Synchronous	Byte Write: A byte Write is LOW for a Write cycle and HIGH for a Read cycle. BW1 controls DQ1–DQ8. BW2 controls DQ9–DQ16. BW3 controls DQ17–DQ24. BW4 controls DQ25–DQ32. Data I/O are high-impedance if either of these inputs are LOW, conditioned by BWE being LOW.
BWE	Input-Synchronous	Write Enable: This active LOW input gates byte Write operations and must meet the set-up and hold times around the rising edge of CLK.
GW	Input-Synchronous	Global Write: This active LOW input allows a full 32-bit Write to occur independent of the BWE and BWN lines and must meet the set-up and hold times around the rising edge of CLK.

Pin Descriptions

Name	Type	Description
CLK	Input-Synchronous	Clock: This signal registers the addresses, data, chip enables, Write control and burst control inputs on its rising edge. All synchronous inputs must meet set-up and hold times around the clock's rising edge.
CE	Input-Synchronous	Chip Enable: This active LOW input is used to enable the device and to gate ADSP.
CE2	Input-Synchronous	Chip Enable: This active LOW input is used to enable the device.
CE2	Input-Synchronous	Chip Enable: This active HIGH input is used to enable the device.
OE	Input	Output Enable: This active LOW asynchronous input enables the data output drivers.
ADV	Input-Synchronous	Address Advance: This active LOW input is used to control the internal burst counter. A HIGH on this pin generates wait cycle (no address advance).
ADSP	Input-Synchronous	Address Status Processor: This active LOW input, along with CE being LOW, causes a new external address to be registered and a Read cycle is initiated using the new address.
ADSC	Input-Synchronous	Address Status Controller: This active LOW input causes device to be de-selected or selected along with new external address to be registered. A Read or Write cycle is initiated depending upon Write control inputs.
MODE	Input-Static	Mode: This input selects the burst sequence. A LOW on this pin selects Linear Burst. A NC or HIGH on this pin selects Interleaved Burst.
ZZ	Input-Asynchronous	Snooze: This active HIGH input puts the device in low power consumption standby mode. For normal operation, this input has to be either LOW or NC (No Connect).
DQ1–DQ32	Input/Output	Data Inputs/Outputs: First Byte is DQ1–DQ8. Second Byte is DQ9–DQ16. Third Byte is DQ17–DQ24. Fourth Byte is DQ25–DQ32. Input data must meet set-up and hold times around the rising edge of CLK.
V _{CC}	Supply	Power Supply: +3.3V –5% to +10%. Pin 14 does not have to be connected directly to V _{CC} as long as it is greater than V _{IH} .
V _{SS}	Ground	Ground: GND
V _{CCQ}	I/O Supply	Output Buffer Supply: +3.3V –5% to +10%. For 2.5V I/O: 2.375V to V _{CC} .
V _{SSQ}	I/O Ground	Output Buffer Ground: GND
NC	-	No Connect: These signals are not internally connected.

Burst Address Table (MODE = NC/V_{CC})

First Address (external)	Second Address (internal)	Third Address (internal)	Fourth Address (internal)
A...A00	A...A01	A...A10	A...A11
A...A01	A...A00	A...A11	A...A10
A...A10	A...A11	A...A00	A...A01
A...A11	A...A10	A...A01	A...A00

Burst Address Table (MODE = GND)

First Address (external)	Second Address (internal)	Third Address (internal)	Fourth Address (internal)
A...A00	A...A01	A...A10	A...A11
A...A01	A...A10	A...A11	A...A00
A...A10	A...A11	A...A00	A...A01
A...A11	A...A00	A...A01	A...A10

Truth Table^[2, 3, 4, 5, 6, 7, 8]

Operation	Address Used	$\overline{\text{CE}}$	$\overline{\text{CE2}}$	CE2	$\overline{\text{ADSP}}$	$\overline{\text{ADSC}}$	$\overline{\text{ADV}}$	$\overline{\text{WRITE}}$	$\overline{\text{OE}}$	CLK	DQ
Deselected Cycle, Power-down	None	H	X	X	X	L	X	X	X	L-H	High-Z
Deselected Cycle, Power-down	None	L	X	L	L	X	X	X	X	L-H	High-Z
Deselected Cycle, Power-down	None	L	H	X	L	X	X	X	X	L-H	High-Z
Deselected Cycle, Power-down	None	L	X	L	H	L	X	X	X	L-H	High-Z
Deselected Cycle, Power-down	None	L	H	X	H	L	X	X	X	L-H	High-Z
Read Cycle, Begin Burst	External	L	L	H	L	X	X	X	L	L-H	Q
Read Cycle, Begin Burst	External	L	L	H	L	X	X	X	H	L-H	High-Z
Write Cycle, Begin Burst	External	L	L	H	H	L	X	L	X	L-H	D
Read Cycle, Begin Burst	External	L	L	H	H	L	X	H	L	L-H	Q
Read Cycle, Begin Burst	External	L	L	H	H	L	X	H	H	L-H	High-Z
Read Cycle, Continue Burst	Next	X	X	X	H	H	L	H	L	L-H	Q
Read Cycle, Continue Burst	Next	X	X	X	H	H	L	H	H	L-H	High-Z
Read Cycle, Continue Burst	Next	H	X	X	X	H	L	H	L	L-H	Q
Read Cycle, Continue Burst	Next	H	X	X	X	H	L	H	H	L-H	High-Z
Write Cycle, Continue Burst	Next	X	X	X	H	H	L	L	X	L-H	D
Write Cycle, Continue Burst	Next	H	X	X	X	H	L	L	X	L-H	D
Read Cycle, Suspend Burst	Current	X	X	X	H	H	H	H	L	L-H	Q
Read Cycle, Suspend Burst	Current	X	X	X	H	H	H	H	H	L-H	High-Z
Read Cycle, Suspend Burst	Current	H	X	X	X	H	H	H	L	L-H	Q
Read Cycle, Suspend Burst	Current	H	X	X	X	H	H	H	H	L-H	High-Z
Write Cycle, Suspend Burst	Current	X	X	X	H	H	H	L	X	L-H	D
Write Cycle, Suspend Burst	Current	H	X	X	X	H	H	L	X	L-H	D

Partial Truth Table for Read/Write

FUNCTION	$\overline{\text{GW}}$	$\overline{\text{BWE}}$	$\overline{\text{BW1}}$	$\overline{\text{BW2}}$	$\overline{\text{BW3}}$	$\overline{\text{BW4}}$
Read	H	H	X	X	X	X
Read	H	L	H	H	H	H
Write one byte	H	L	L	H	H	H
Write all bytes	H	L	L	L	L	L
Write all bytes	L	X	X	X	X	X

Notes:

- X means "Don't Care." H means logic HIGH. L means logic LOW. $\overline{\text{Write}} = \text{L}$ means $[\overline{\text{BWE}} + \overline{\text{BW1}} \cdot \overline{\text{BW2}} \cdot \overline{\text{BW3}} \cdot \overline{\text{BW4}}] \cdot \overline{\text{GW}}$ equals LOW. $\overline{\text{Write}} = \text{H}$ means $[\overline{\text{BWE}} + \overline{\text{BW1}} \cdot \overline{\text{BW2}} \cdot \overline{\text{BW3}} \cdot \overline{\text{BW4}}] \cdot \overline{\text{GW}}$ equals HIGH.
- BW1 enables Write to DQ1–DQ8. BW2 enables Write to DQ9–DQ16. BW3 enables Write to DQ17–DQ24. BW4 enables Write to DQ25–DQ32.
- All inputs except OE must meet set-up and hold times around the rising edge (LOW–HIGH) of CLK.
- Suspending burst generates Wait cycle.
- For a Write operation following a Read operation, $\overline{\text{OE}}$ must be HIGH before the input data required set-up time plus High-Z time for $\overline{\text{OE}}$ and staying HIGH throughout the input data hold time.
- This device contains circuitry that will ensure the outputs will be in High-Z during power-up.
- ADSP LOW along with chip being selected always initiates a Read cycle at the L–H edge of CLK. A Write cycle can be performed by setting $\overline{\text{Write}}$ LOW for the CLK L–H edge of the subsequent wait cycle. Refer to Write timing diagram for clarification.

Maximum Ratings

(Above which the useful life may be impaired. For user guidelines, not tested.)

Voltage on V_{CC} Supply Relative to V_{SS} -0.5V to +4.6V
 V_{IN} -0.5V to $V_{CC}+0.5V$
 Storage Temperature (plastic) -55°C to +150°C
 Junction Temperature +150°C

Power Dissipation..... 1.0W
 Short Circuit Output Current..... 50 mA

Operating Range

Range	Ambient Temperature ^[9]	V_{DD} ^[10,11]
Commercial	0°C to +70°C	3.3V -5%/+10%
Industrial	-40°C to +85°C	

Electrical Characteristics Over the Operating Range

Parameter	Description	Test Conditions	Min.	Max.	Unit
V_{IHD}	Input HIGH (Logic 1) Voltage ^[12, 13]	Data Inputs (DQxx)	2.0	$V_{CCQ} + 0.3$	V
V_{IH}		All Other Inputs	2.0	4.6	V
V_{IL}	Input LOW (Logic 0) Voltage ^[12, 13]		-0.3	0.8	V
I_{LI}	Input Leakage Current ^[14]	$0V \leq V_{IN} \leq V_{CC}$	-2	2	μA
I_{LO}	Output Leakage Current	Output(s) disabled, $0V \leq V_{OUT} \leq V_{CC}$	-2	2	μA
V_{OH}	Output HIGH Voltage ^[12, 15]	$I_{OH} = -4.0$ mA	2.4		V
V_{OL}	Output LOW Voltage ^[12, 15]	$I_{OL} = 8.0$ mA		0.4	V
V_{CC}	Supply Voltage ^[12]		3.1	3.6	V
V_{CCQ}	I/O Supply Voltage (3.3V I/O) ^[12]		3.1	3.6	V
V_{CCQ}	I/O Supply Voltage (2.5V I/O) ^[12]		2.375	V_{CC}	

Parameter	Description	Conditions	Typ.	-5	-7	Unit
I_{CC}	Power Supply Current: Operating ^[16, 17, 18]	Device selected; all inputs $\leq V_{IL}$ or $\geq V_{IH}$; cycle time $\geq t_{KC}$ min.; $V_{CC} = \text{Max.}$; outputs open	80	225	120	mA
I_{SB2}	CMOS Standby ^[17, 18]	Device deselected; $V_{CC} = \text{Max.}$; all inputs $\leq V_{SS} + 0.2$ or $\geq V_{CC} - 0.2$; all inputs static; CLK frequency = 0	0.2	2	2	mA
I_{SB3}	TTL Standby ^[17, 18]	Device deselected; all inputs $\leq V_{IL}$ or $\geq V_{IH}$; all inputs static; $V_{CC} = \text{Max.}$; CLK frequency = 0	8	18	18	mA
I_{SB4}	Clock Running ^[17, 18]	Device deselected; all inputs $\leq V_{IL}$ or $\geq V_{IH}$; $V_{CC} = \text{Max.}$; CLK cycle time $\geq t_{KC}$ min.	12	30	20	mA

Capacitance^[19]

Parameter	Description	Test Conditions	Typ.	Max.	Unit
C_I	Input Capacitance	$T_A = 25^\circ C$, $f = 1$ MHz, $V_{CC} = 3.3V$	3	4	pF
C_O	Input/Output Capacitance (DQ)		6	7	pF

Capacitance Derating^[20]

Parameter	Description	Typ.	Max.	Unit
Δt_{KQ}	Clock to Output Valid	0.016		ns/pF

Notes:

9. T_A is the case temperature.
10. Please refer to waveform (d).
11. Power supply ramp-up should be monotonic.
12. All voltages referenced to V_{SS} (GND).
13. Overshoot: $V_{IH} \leq +6.0V$ for $t \leq t_{KC}/2$.
Undershoot: $V_{IL} \leq -2.0V$ for $t \leq t_{KC}/2$.
14. MODE pin has an internal pull-up and ZZ pin has an internal pull-down. These two pins exhibit an input leakage current of $\pm 30 \mu A$.
15. AC I/O curves are available upon request.
16. I_{CC} is given with no output current. I_{CC} increases with greater output loading and faster cycle times.
17. "Device Deselected" means the device is in power-down mode as defined in the truth table. "Device Selected" means the device is active.
18. Typical values are measured at 3.3V, 25°C, and 8.5-ns cycle time.
19. This parameter is sampled.
20. Capacitance derating applies to capacitance different from the load capacitance shown in AC Test Loads for 3.3V or 2.5V I/O.

Thermal Resistance

Parameter	Description	Test Conditions	TQFP Typ.	Unit
Θ_{JA}	Thermal Resistance (Junction to Ambient)	Still air, soldered on a 4.25 × 1.125 inch, four-layer PCB	20	°C/W
Θ_{JC}	Thermal Resistance (Junction to Case)		1	°C/W

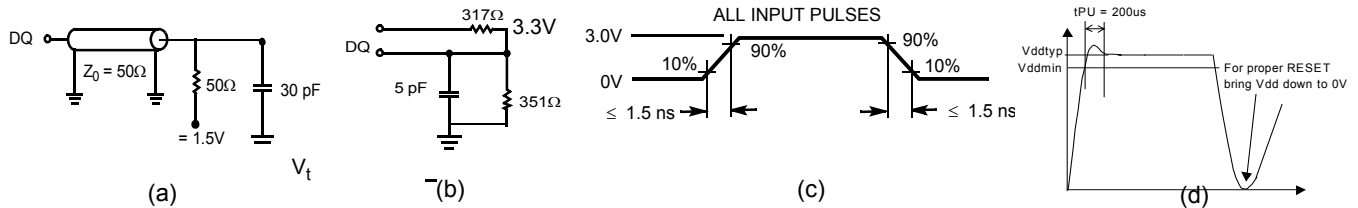
AC Test Loads and Waveforms—3.3V I/O^[21]

AC Test Loads and Waveforms—2.5V I/O

Switching Characteristics Over the Operating Range^[22]

Parameter	Description	-5 100 MHz		-7 66 MHz		Unit
		Min.	Max.	Min.	Max.	
Clock						
t _{KC}	Clock Cycle Time	10		15		ns
t _{KH}	Clock HIGH Time	4		5		ns
t _{KL}	Clock LOW Time	4		5		ns
Output Times						
t _{KQ}	Clock to Output Valid		5		7	ns
t _{KQX}	Clock to Output Invalid	2		2		ns
t _{KQLZ}	Clock to Output in Low-Z ^[23, 24]	3		3		ns
t _{KQHZ}	Clock to Output in High-Z ^[23, 24]		5		6	ns
t _{OEQ}	OE to Output Valid ^[25]		5		7	ns
t _{OELZ}	OE to Output in Low-Z ^[23, 24]	0		0		ns
t _{OEHZ}	OE to Output in High-Z ^[23, 24]		4		6	ns
Set-up Times						
t _S	Address, Controls, and Data In ^[26]	2.5		2.5		ns
Hold Times						
t _H	Address, Controls, and Data In ^[26]	0.5		0.5		ns

Notes:

21. Overshoot: $V_{IH}(AC) < V_{DD} + 1.5V$ for $t < t_{TCYC}/2$; undershoot: $V_{IL}(AC) < 0.5V$ for $t < t_{TCYC}/2$; power-up: $V_{IH} < 2.6V$ and $V_{DD} < 2.4V$ and $V_{DDQ} < 1.4V$ for $t < 200$ ms.

22. Test conditions as specified with the output loading as shown in (a) of AC Test Loads unless otherwise noted.

23. Output loading is specified with $C_L = 5$ pF as in part (b) of AC Test Loads.

24. At any given temperature and voltage condition, t_{KQHZ} is less than t_{KQLZ} and t_{OEHZ} is less than t_{OELZ} .

25. OE is a "Don't Care" when a byte Write enable is sampled LOW.

26. This is a synchronous device. All synchronous inputs must meet specified set-up and hold time, except for "don't care" as defined in the truth table.

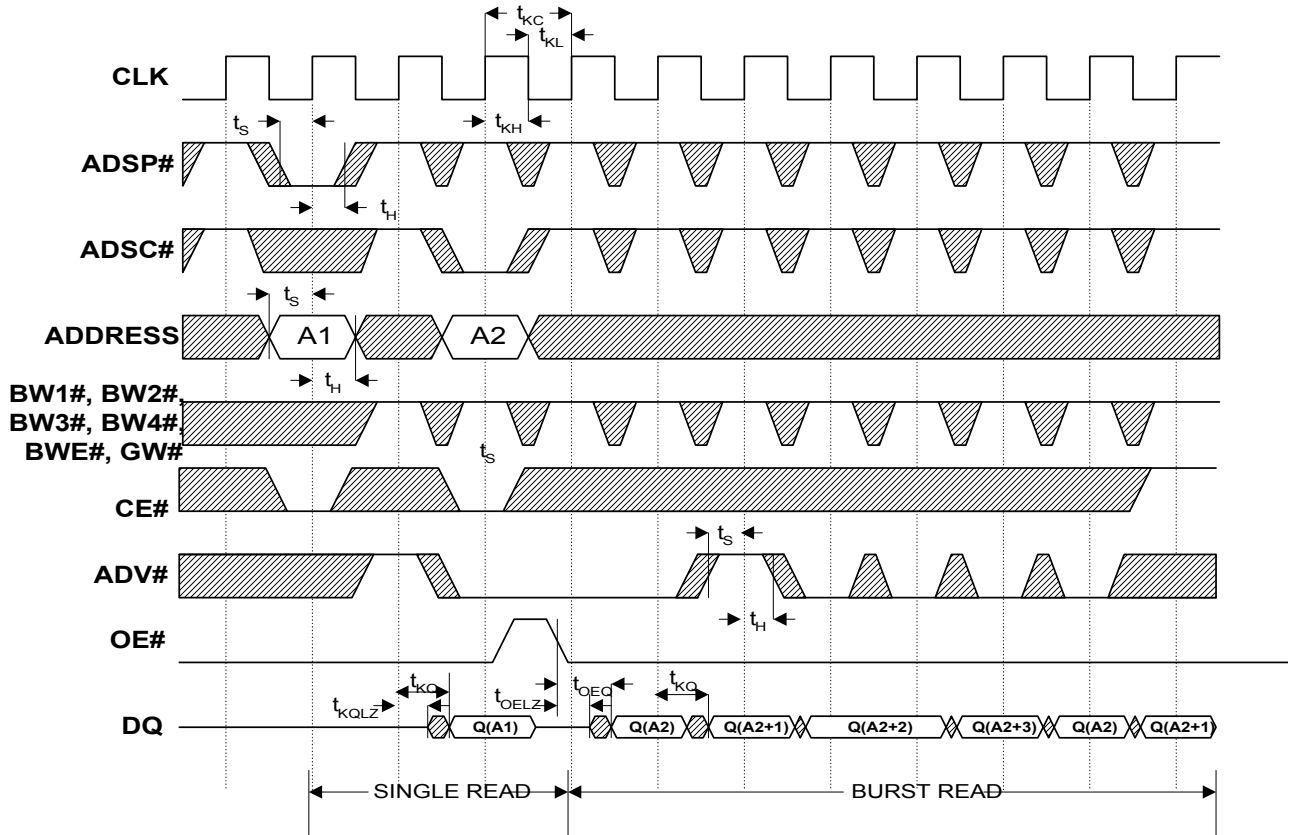
Switching Waveforms
Read Timing^[27]

Note:
 27. \overline{CE} active in this timing diagram means that all chip enables \overline{CE} , $\overline{CE2}$, and $\overline{CE2}$ are active.

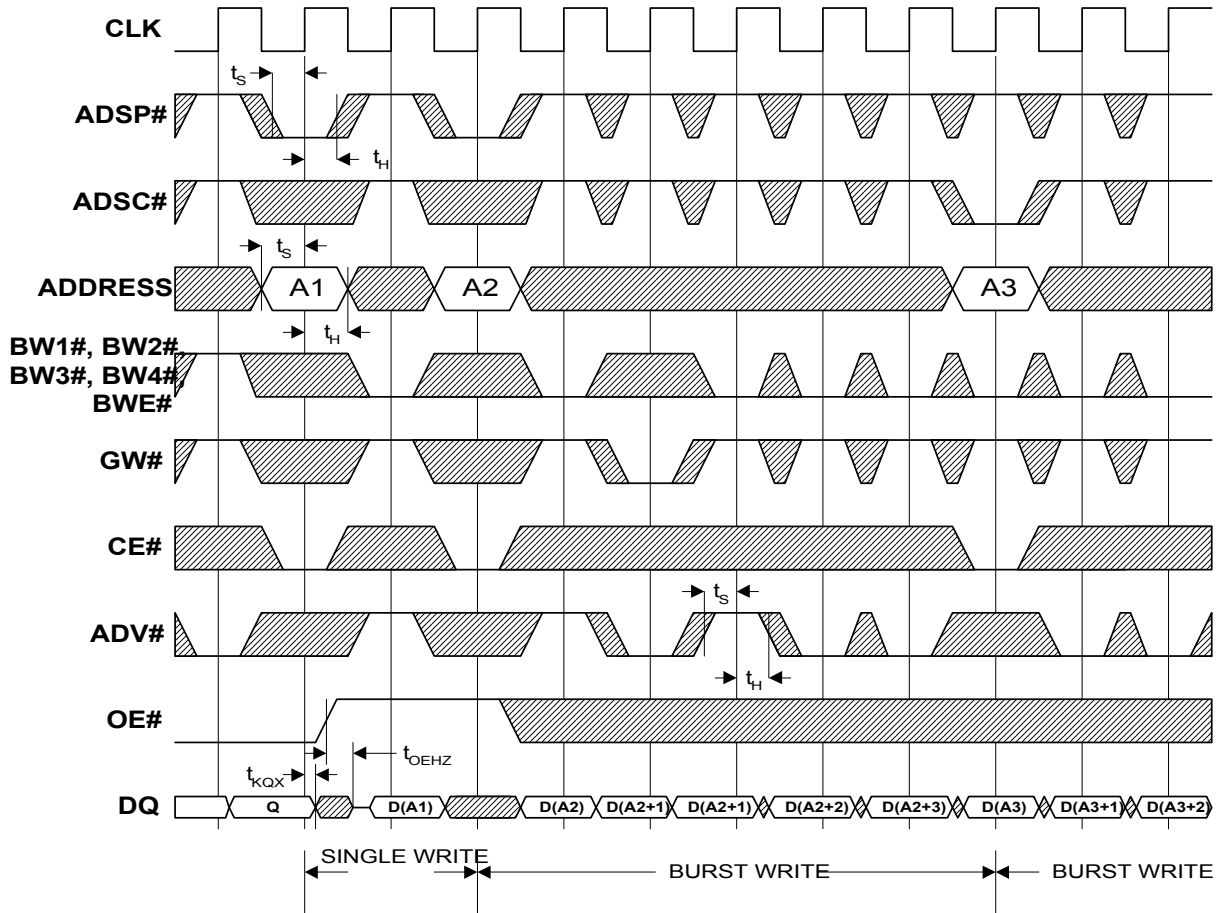
Switching Waveforms (continued)
Write Timing^[27]

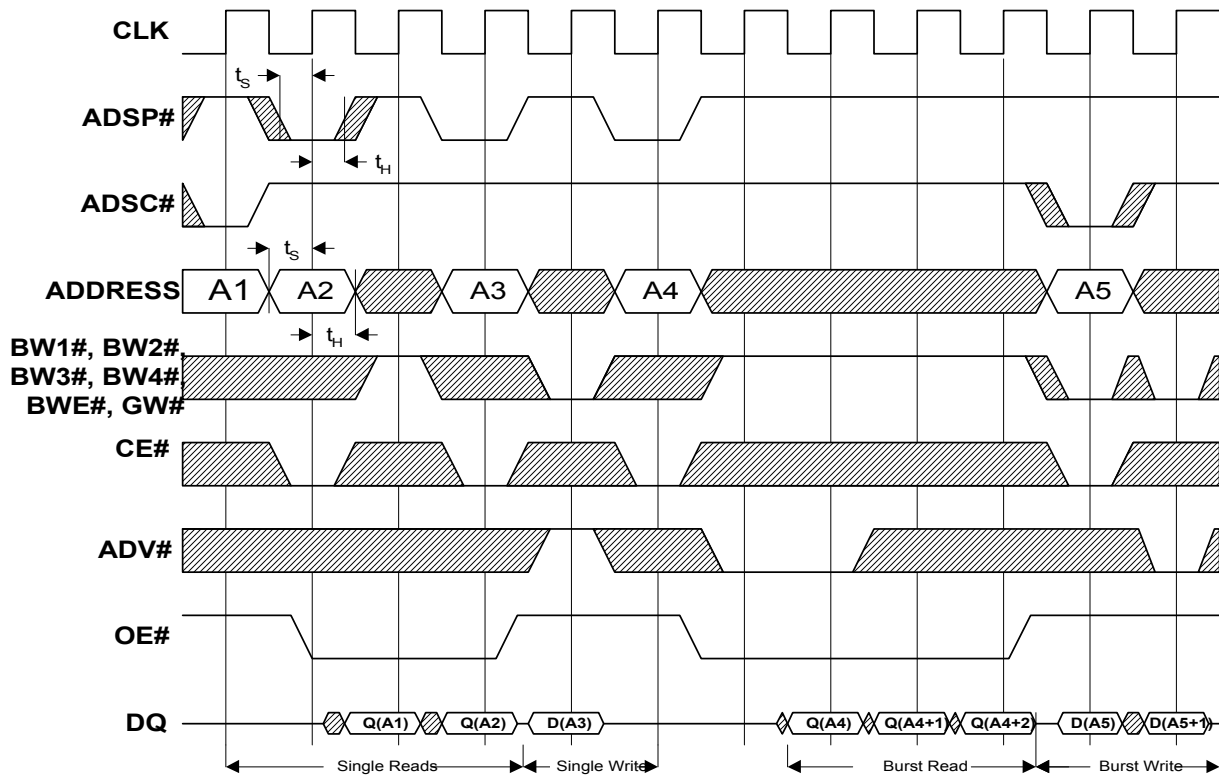
Switching Waveforms (continued)
Read/Write Timing^[27]

Ordering Information

Speed (MHz)	Ordering Code	Package Name	Package Type	Operating Range
100	CY7C1340A-100AC	A101	100-lead 14 × 20 × 1.4 mm Thin Quad Flat Pack	Commercial
66	CY7C1340A-66AI	A101	100-lead 14 × 20 × 1.4 mm Thin Quad Flat Pack	Industrial

Package Diagrams
100-pin Thin Plastic Quad Flatpack (14 × 20 × 1.4 mm) A101

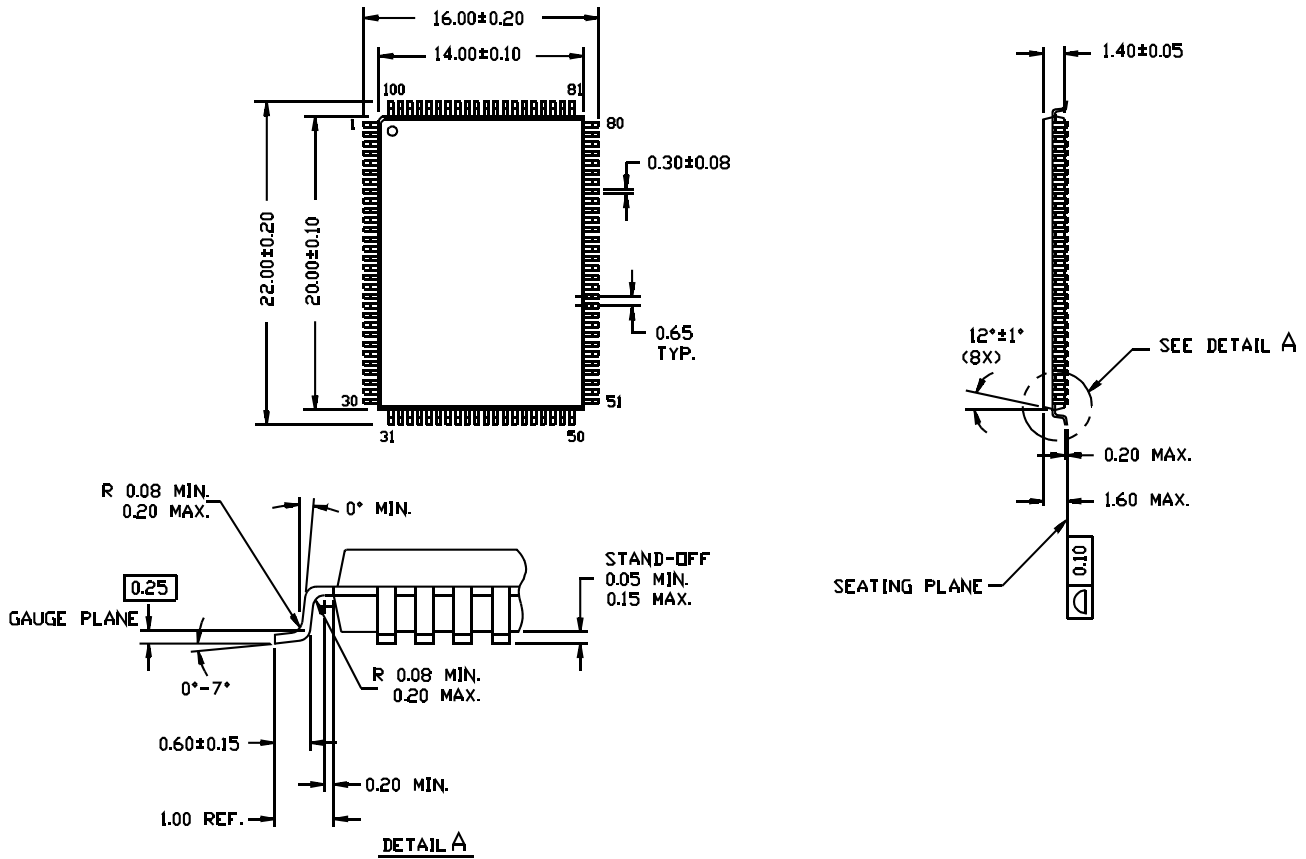
DIMENSIONS ARE IN MILLIMETERS.



51-85050-*A

Pentium is a registered trademark of Intel Corporation. PowerPC is a trademark of IBM Corporation. All products and company names mentioned in this document are the trademarks of their respective holders.

Document History Page

Document Title: CY7C1340A 128K × 32 Synchronous-Pipelined RAM				
Document Number: 38-05153				
REV.	ECN NO.	Issue Date	Orig. of Change	Description of Change
**	109897	09/22/01	SZV	Changed from Spec number: 38-01003 to 38-05153
*A	111530	02/06/02	GLC	Added industrial temp to data sheet
*B	123139	01/19/03	RBI	Added power up requirements to operating conditions information.
*C	212291	See ECN	VBL	Deleted Galvantech info. from title and contents Updated ordering info to match devmaster Deleted 83 MHz (-6)



LittleDiode supplies new, hard to find or obsolete electronic components and semiconductors all over the world.

With over two million different components listed you are sure to find the part you need.

Feel free to visit us today at our online store:

LittleDiode.com

Looking forward to providing you with the best possible service.