



512K x 36/1M x 18 Pipelined SRAM with NoBL™ Architecture

Features

- Pin-compatible and functionally equivalent to ZBT™
- Supports 250-MHz bus operations with zero wait states
 - Available speed grades are 250, 225, 200 and 167 MHz
- Internally self-timed output buffer control to eliminate the need to use asynchronous OE
- Fully registered (inputs and outputs) for pipelined operation
- Byte Write capability
- Single 3.3V power supply
- 3.3V/2.5V I/O power supply
- Fast clock-to-output times
 - 2.6 ns (for 250-MHz device)
 - 2.8 ns (for 225-MHz device)
 - 3.0 ns (for 200-MHz device)
 - 3.4 ns (for 167-MHz device)
- Clock Enable (\overline{CEN}) pin to suspend operation
- Synchronous self-timed writes
- Available in 100 TQFP, 119 BGA, and 165 fBGA packages
- IEEE 1149.1 JTAG Boundary Scan
- Burst capability—linear or interleaved burst order
- “ZZ” Sleep Mode option and Stop Clock option

Functional Description

The CY7C1370C and CY7C1372C are 3.3V, 512K x 36 and 1M x 18 Synchronous pipelined burst SRAMs with No Bus Latency™ (NoBL™) logic, respectively. They are designed to support unlimited true back-to-back Read/Write operations with no wait states. The CY7C1370C and CY7C1372C are equipped with the advanced (NoBL) logic required to enable consecutive Read/Write operations with data being transferred on every clock cycle. This feature dramatically improves the throughput of data in systems that require frequent Write/Read transitions. The CY7C1370C and CY7C1372C are pin compatible and functionally equivalent to ZBT devices.

All synchronous inputs pass through input registers controlled by the rising edge of the clock. All data outputs pass through output registers controlled by the rising edge of the clock. The clock input is qualified by the Clock Enable (\overline{CEN}) signal, which when deasserted suspends operation and extends the previous clock cycle.

Write operations are controlled by the Byte Write Selects (BW_a – BW_d for CY7C1370C and BW_a – BW_b for CY7C1372C) and a Write Enable (\overline{WE}) input. All writes are conducted with on-chip synchronous self-timed write circuitry.

Three synchronous Chip Enables (\overline{CE}_1 , \overline{CE}_2 , \overline{CE}_3) and an asynchronous Output Enable (\overline{OE}) provide for easy bank selection and output three-state control. In order to avoid bus contention, the output drivers are synchronously three-stated during the data portion of a write sequence.

Logic Block Diagram-CY7C1370C (512K x 36)

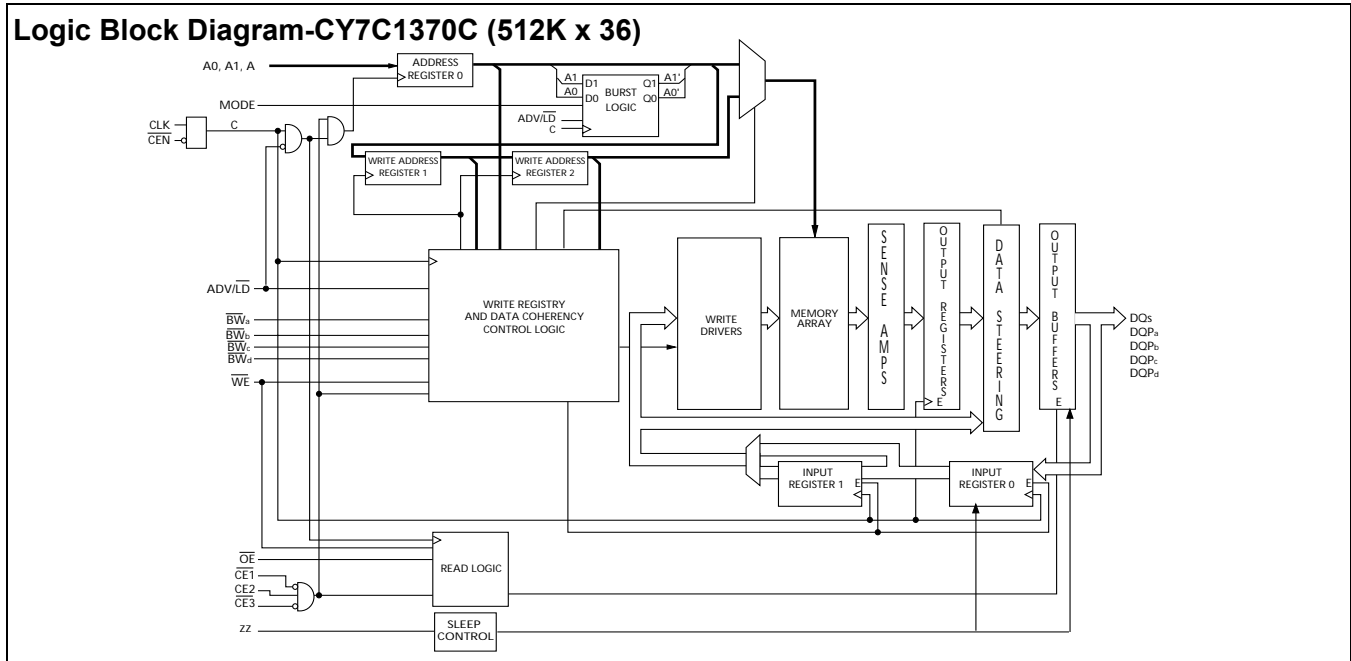

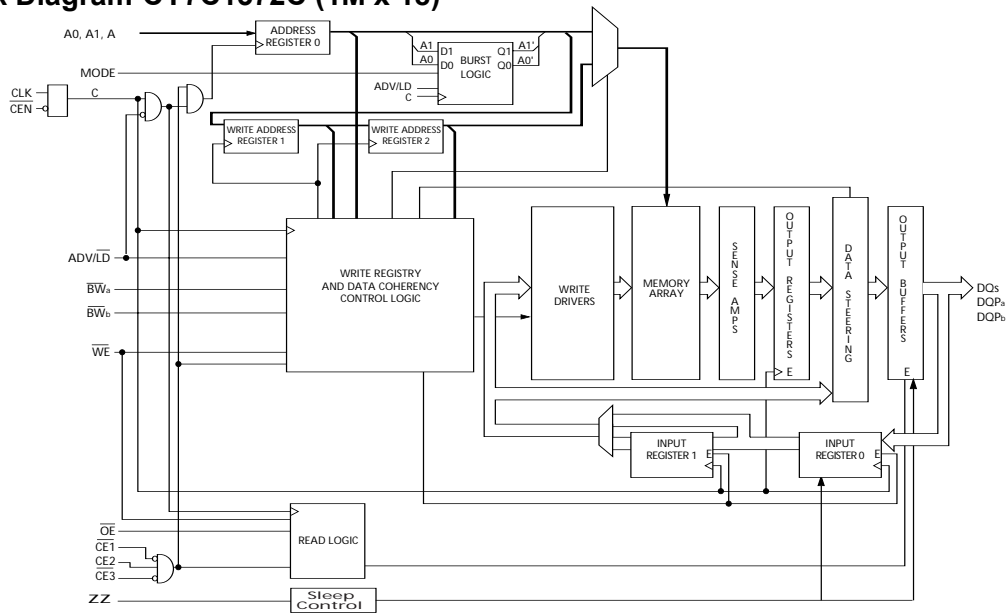
Logic Block Diagram-CY7C1372C (1M x 18)

Selection Guide

	CY7C1370C-250 CY7C1372C-250	CY7C1370C-225 CY7C1372C-225	CY7C1370C-200 CY7C1372C-200	CY7C1370C-167 CY7C1372C-167	Unit
Maximum Access Time	2.6	2.8	3.0	3.4	ns
Maximum Operating Current	350	325	300	275	mA
Maximum CMOS Standby Current	70	70	70	70	mA

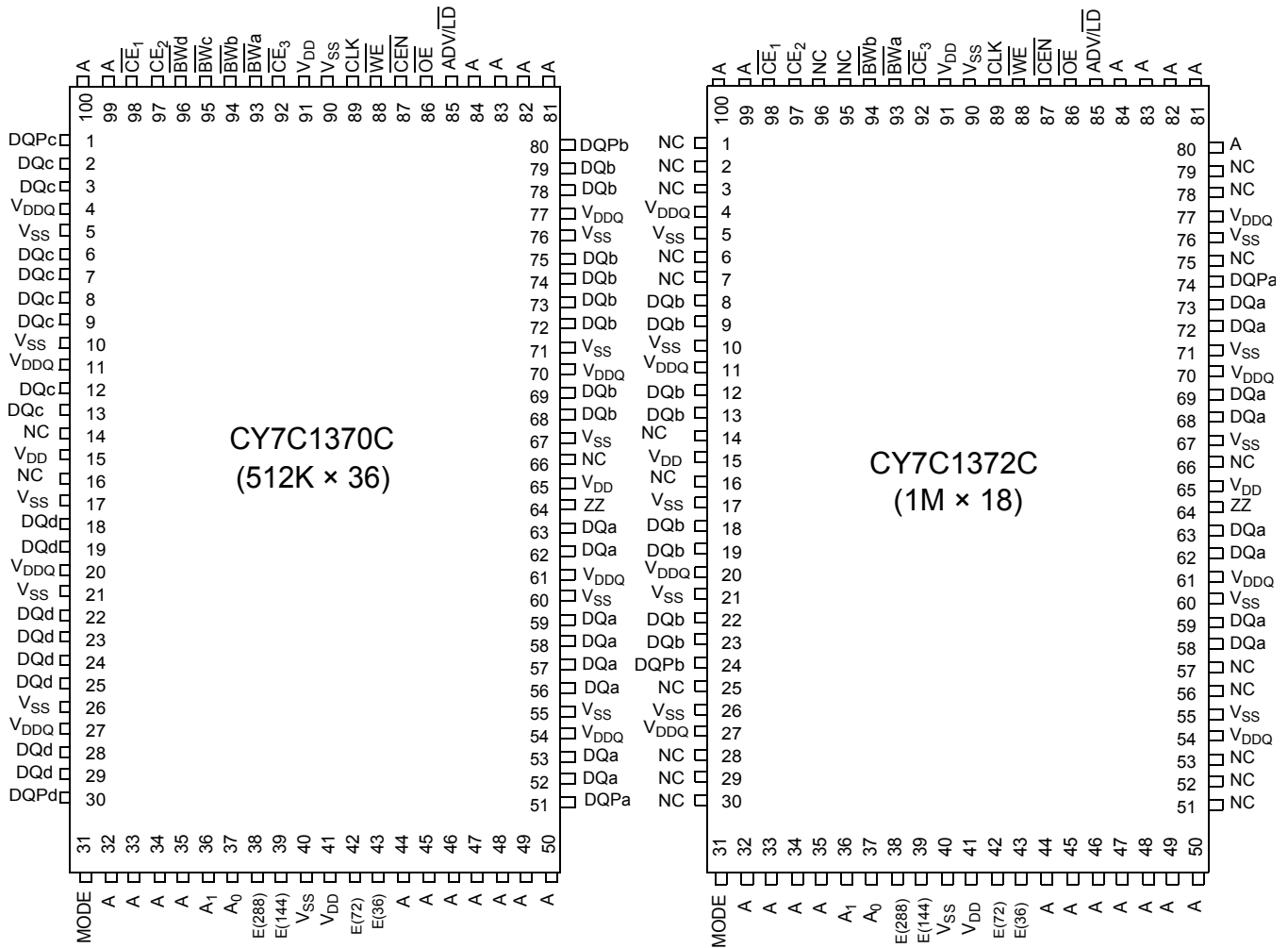
Shaded areas contain advance information. Please contact your local Cypress sales representative for availability of these parts.

Pin Configurations
100-pin TQFP Packages

Pin Configurations (continued)

119-ball BGA Pinout
CY7C1370C (512K × 36) – 14 × 22 BGA

	1	2	3	4	5	6	7
A	V _{DDQ}	A	A	A	A	A	V _{DDQ}
B	NC	CE ₂	A	ADV/LD	A	CE ₃	NC
C	NC	A	A	V _{DD}	A	A	NC
D	DQ _c	DQP _c	V _{SS}	NC	V _{SS}	DQP _b	DQ _b
E	DQ _c	DQ _c	V _{SS}	CE ₁	V _{SS}	DQ _b	DQ _b
F	V _{DDQ}	DQ _c	V _{SS}	OE	V _{SS}	DQ _b	V _{DDQ}
G	DQ _c	DQ _c	BW _c	A	BW _b	DQ _b	DQ _b
H	DQ _c	DQ _c	V _{SS}	WE	V _{SS}	DQ _b	DQ _b
J	V _{DDQ}	V _{DD}	NC	V _{DD}	NC	V _{DD}	V _{DDQ}
K	DQ _d	DQ _d	V _{SS}	CLK	V _{SS}	DQ _a	DQ _a
L	DQ _d	DQ _d	BW _d	NC	BW _a	DQ _a	DQ _a
M	V _{DDQ}	DQ _d	V _{SS}	CEN	V _{SS}	DQ _a	V _{DDQ}
N	DQ _d	DQ _d	V _{SS}	A1	V _{SS}	DQ _a	DQ _a
P	DQ _d	DQP _d	V _{SS}	A0	V _{SS}	DQP _a	DQ _a
R	NC	A	MODE	V _{DD}	NC	A	NC
T	NC	E(72)	A	A	A	E(36)	ZZ
U	V _{DDQ}	TMS	TDI	TCK	TDO	NC	V _{DDQ}

CY7C1372C (1M × 18)–14 × 22 BGA

	1	2	3	4	5	6	7
A	V _{DDQ}	A	A	A	A	A	V _{DDQ}
B	NC	CE ₂	A	ADV/LD	A	CE ₃	NC
C	NC	A	A	V _{DD}	A	A	NC
D	DQ _b	NC	V _{SS}	NC	V _{SS}	DQP _a	NC
E	NC	DQ _b	V _{SS}	CE ₁	V _{SS}	NC	DQ _a
F	V _{DDQ}	NC	V _{SS}	OE	V _{SS}	DQ _a	V _{DDQ}
G	NC	DQ _b	BW _b	A	V _{SS}	NC	DQ _a
H	DQ _b	NC	V _{SS}	WE	V _{SS}	DQ _a	NC
J	V _{DDQ}	V _{DD}	NC	V _{DD}	NC	V _{DD}	V _{DDQ}
K	NC	DQ _b	V _{SS}	CLK	V _{SS}	NC	DQ _a
L	DQ _b	NC	V _{SS}	NC	BW _a	DQ _a	NC
M	V _{DDQ}	DQ _b	V _{SS}	CEN	V _{SS}	NC	V _{DDQ}
N	DQ _b	NC	V _{SS}	A1	V _{SS}	DQ _a	NC
P	NC	DQP _b	V _{SS}	A0	V _{SS}	NC	DQ _a
R	NC	A	MODE	V _{DD}	NC	A	NC
T	E(72)	A	A	E(36)	A	A	ZZ
U	V _{DDQ}	TMS	TDI	TCK	TDO	NC	V _{DDQ}

Pin Configurations (continued)

165-Ball fBGA Pinout
CY7C1370C (512K × 36) – 13 × 15 fBGA

	1	2	3	4	5	6	7	8	9	10	11
A	E(288)	A	\overline{CE}_1	\overline{BW}_c	\overline{BW}_b	\overline{CE}_3	\overline{CEN}	ADV/LD	A	A	NC
B	NC	A	CE2	\overline{BW}_d	\overline{BW}_a	CLK	\overline{WE}	\overline{OE}	A	A	E(144)
C	DQP _c	NC	V _{DDQ}	V _{SS}	V _{SS}	V _{SS}	V _{SS}	V _{SS}	V _{DDQ}	NC	DQP _b
D	DQ _c	DQ _c	V _{DDQ}	V _{DD}	V _{SS}	V _{SS}	V _{SS}	V _{DD}	V _{DDQ}	DQ _b	DQ _b
E	DQ _c	DQ _c	V _{DDQ}	V _{DD}	V _{SS}	V _{SS}	V _{SS}	V _{DD}	V _{DDQ}	DQ _b	DQ _b
F	DQ _c	DQ _c	V _{DDQ}	V _{DD}	V _{SS}	V _{SS}	V _{SS}	V _{DD}	V _{DDQ}	DQ _b	DQ _b
G	DQ _c	DQ _c	V _{DDQ}	V _{DD}	V _{SS}	V _{SS}	V _{SS}	V _{DD}	V _{DDQ}	DQ _b	DQ _b
H	NC	NC / V _{DD}	NC	V _{DD}	V _{SS}	V _{SS}	V _{SS}	V _{DD}	NC	NC	ZZ
J	DQ _d	DQ _d	V _{DDQ}	V _{DD}	V _{SS}	V _{SS}	V _{SS}	V _{DD}	V _{DDQ}	DQ _a	DQ _a
K	DQ _d	DQ _d	V _{DDQ}	V _{DD}	V _{SS}	V _{SS}	V _{SS}	V _{DD}	V _{DDQ}	DQ _a	DQ _a
L	DQ _d	DQ _d	V _{DDQ}	V _{DD}	V _{SS}	V _{SS}	V _{SS}	V _{DD}	V _{DDQ}	DQ _a	DQ _a
M	DQ _d	DQ _d	V _{DDQ}	V _{DD}	V _{SS}	V _{SS}	V _{SS}	V _{DD}	V _{DDQ}	DQ _a	DQ _a
N	DQP _d	NC	V _{DDQ}	V _{SS}	NC	NC	NC	V _{SS}	V _{DDQ}	NC	DQP _a
P	NC	E(72)	A	A	TDI	A1	TDO	A	A	A	NC
R	MODE	E(36)	A	A	TMS	A0	TCK	A	A	A	A

CY7C1372C (1M × 18) – 13 × 15 fBGA

	1	2	3	4	5	6	7	8	9	10	11
A	E(288)	A	\overline{CE}_1	\overline{BW}_b	NC	\overline{CE}_3	\overline{CEN}	ADV/LD	A	A	A
B	NC	A	CE2	NC	\overline{BW}_a	CLK	\overline{WE}	\overline{OE}	A	A	E(144)
C	NC	NC	V _{DDQ}	V _{SS}	V _{SS}	V _{SS}	V _{SS}	V _{SS}	V _{DDQ}	NC	DQP _a
D	NC	DQ _b	V _{DDQ}	V _{DD}	V _{SS}	V _{SS}	V _{SS}	V _{DD}	V _{DDQ}	NC	DQ _a
E	NC	DQ _b	V _{DDQ}	V _{DD}	V _{SS}	V _{SS}	V _{SS}	V _{DD}	V _{DDQ}	NC	DQ _a
F	NC	DQ _b	V _{DDQ}	V _{DD}	V _{SS}	V _{SS}	V _{SS}	V _{DD}	V _{DDQ}	NC	DQ _a
G	NC	DQ _b	V _{DDQ}	V _{DD}	V _{SS}	V _{SS}	V _{SS}	V _{DD}	V _{DDQ}	NC	DQ _a
H	NC	NC / V _{DD}	NC	V _{DD}	V _{SS}	V _{SS}	V _{SS}	V _{DD}	NC	NC	ZZ
J	DQ _b	NC	V _{DDQ}	V _{DD}	V _{SS}	V _{SS}	V _{SS}	V _{DD}	V _{DDQ}	DQ _a	NC
K	DQ _b	NC	V _{DDQ}	V _{DD}	V _{SS}	V _{SS}	V _{SS}	V _{DD}	V _{DDQ}	DQ _a	NC
L	DQ _b	NC	V _{DDQ}	V _{DD}	V _{SS}	V _{SS}	V _{SS}	V _{DD}	V _{DDQ}	DQ _a	NC
M	DQ _b	NC	V _{DDQ}	V _{DD}	V _{SS}	V _{SS}	V _{SS}	V _{DD}	V _{DDQ}	DQ _a	NC
N	DQP _b	NC	V _{DDQ}	V _{SS}	NC	NC	NC	V _{SS}	V _{DDQ}	NC	NC
P	NC	E(72)	A	A	TDI	A1	TDO	A	A	A	NC
R	MODE	E(36)	A	A	TMS	A0	TCK	A	A	A	A

Pin Definitions

Pin Name	I/O Type	Pin Description
A0 A1 A	Input-Synchronous	Address Inputs used to select one of the address locations. Sampled at the rising edge of the CLK.
BW _a BW _b BW _c BW _d	Input-Synchronous	Byte Write Select Inputs, active LOW. Qualified with WE to conduct writes to the SRAM. Sampled on the rising edge of CLK. BW _a controls DQ _a and DQP _a , BW _b controls DQ _b and DQP _b , BW _c controls DQ _c and DQP _c , BW _d controls DQ _d and DQP _d .
WE	Input-Synchronous	Write Enable Input, active LOW. Sampled on the rising edge of CLK if CEN is active LOW. This signal must be asserted LOW to initiate a write sequence.
ADV/LD	Input-Synchronous	Advance/Load Input used to advance the on-chip address counter or load a new address. When HIGH (and CEN is asserted LOW) the internal burst counter is advanced. When LOW, a new address can be loaded into the device for an access. After being deselected, ADV/LD should be driven LOW in order to load a new address.
CLK	Input-Clock	Clock Input. Used to capture all synchronous inputs to the device. CLK is qualified with CEN. CLK is only recognized if CEN is active LOW.
CE ₁	Input-Synchronous	Chip Enable 1 Input, active LOW. Sampled on the rising edge of CLK. Used in conjunction with CE ₂ and CE ₃ to select/deselect the device.
CE ₂	Input-Synchronous	Chip Enable 2 Input, active HIGH. Sampled on the rising edge of CLK. Used in conjunction with CE ₁ and CE ₃ to select/deselect the device.
CE ₃	Input-Synchronous	Chip Enable 3 Input, active LOW. Sampled on the rising edge of CLK. Used in conjunction with CE ₁ and CE ₂ to select/deselect the device.
OE	Input-Asynchronous	Output Enable, active LOW. Combined with the synchronous logic block inside the device to control the direction of the I/O pins. When LOW, the I/O pins are allowed to behave as outputs. When deasserted HIGH, I/O pins are three-stated, and act as input data pins. OE is masked during the data portion of a write sequence, during the first clock when emerging from a deselected state and when the device has been deselected.
CEN	Input-Synchronous	Clock Enable Input, active LOW. When asserted LOW the clock signal is recognized by the SRAM. When deasserted HIGH the clock signal is masked. Since deasserting CEN does not deselect the device, CEN can be used to extend the previous cycle when required.
DQ _a DQ _b DQ _c DQ _d	I/O-Synchronous	Bidirectional Data I/O lines. As inputs, they feed into an on-chip data register that is triggered by the rising edge of CLK. As outputs, they deliver the data contained in the memory location specified by A _[17:0] during the previous clock rise of the read cycle. The direction of the pins is controlled by OE and the internal control logic. When OE is asserted LOW, the pins can behave as outputs. When HIGH, DQ _a –DQ _d are placed in a three-state condition. The outputs are automatically three-stated during the data portion of a write sequence, during the first clock when emerging from a deselected state, and when the device is deselected, regardless of the state of OE.
DQP _a DQP _b DQP _c DQP _d	I/O-Synchronous	Bidirectional Data Parity I/O lines. Functionally, these signals are identical to DQ _[31:0] . During write sequences, DQP _a is controlled by BW _a , DQP _b is controlled by BW _b , DQP _c is controlled by BW _c , and DQP _d is controlled by BW _d .
MODE	Input Strap Pin	Mode Input. Selects the burst order of the device. Tied HIGH selects the interleaved burst order. Pulled LOW selects the linear burst order. MODE should not change states during operation. When left floating MODE will default HIGH, to an interleaved burst order.
TDO	JTAG serial output Synchronous	Serial data-out to the JTAG circuit. Delivers data on the negative edge of TCK.
TDI	JTAG serial input Synchronous	Serial data-In to the JTAG circuit. Sampled on the rising edge of TCK.
TMS	Test Mode Select Synchronous	This pin controls the Test Access Port state machine. Sampled on the rising edge of TCK.
TCK	JTAG-Clock	Clock input to the JTAG circuitry.
V _{DD}	Power Supply	Power supply inputs to the core of the device.
V _{DDQ}	I/O Power Supply	Power supply for the I/O circuitry.

Pin Definitions (continued)

Pin Name	I/O Type	Pin Description
V _{SS}	Ground	Ground for the device. Should be connected to ground of the system.
NC	–	No connects. This pin is not connected to the die.
NC / VDD	–	Can either be left unconnected or connected to V_{DD}. Must not be connected to V _{SS} .
E(36,72, 144, 288)	–	These pins are not connected. They will be used for expansion to the 36M, 72M, 144M and 288M densities.
ZZ	Input-Asynchronous	ZZ “sleep” Input. This active HIGH input places the device in a non-time critical “sleep” condition with data integrity preserved. During normal operation, this pin can be connected to V _{SS} or left floating.

Functional Overview

The CY7C1370C and CY7C1372C are synchronous-pipelined Burst NoBL SRAMs designed specifically to eliminate wait states during Write/Read transitions. All synchronous inputs pass through input registers controlled by the rising edge of the clock. The clock signal is qualified with the Clock Enable input signal (CEN). If CEN is HIGH, the clock signal is not recognized and all internal states are maintained. All synchronous operations are qualified with CEN. All data outputs pass through output registers controlled by the rising edge of the clock. Maximum access delay from the clock rise (t_{CO}) is 3.0 ns (200-MHz device).

Accesses can be initiated by asserting all three Chip Enables (\overline{CE}_1 , \overline{CE}_2 , \overline{CE}_3) active at the rising edge of the clock. If Clock Enable (CEN) is active LOW and ADV/LD is asserted LOW, the address presented to the device will be latched. The access can either be a read or write operation, depending on the status of the Write Enable (WE). $BW_{[a:d]}$ can be used to conduct byte write operations.

Write operations are qualified by the Write Enable (\overline{WE}). All writes are simplified with on-chip synchronous self-timed write circuitry.

Three synchronous Chip Enables (\overline{CE}_1 , \overline{CE}_2 , \overline{CE}_3) and an asynchronous Output Enable (OE) simplify depth expansion. All operations (Reads, Writes, and Deselects) are pipelined. ADV/LD should be driven LOW once the device has been deselected in order to load a new address for the next operation.

Single Read Accesses

A read access is initiated when the following conditions are satisfied at clock rise: (1) CEN is asserted LOW, (2) \overline{CE}_1 , \overline{CE}_2 , and \overline{CE}_3 are ALL asserted active, (3) the Write Enable input signal WE is deasserted HIGH, and (4) ADV/LD is asserted LOW. The address presented to the address inputs is latched into the Address Register and presented to the memory core and control logic. The control logic determines that a read access is in progress and allows the requested data to propagate to the input of the output register. At the rising edge of the next clock the requested data is allowed to propagate through the output register and onto the data bus within 3.2 ns (200-MHz device) provided \overline{OE} is active LOW. After the first clock of the read access the output buffers are controlled by OE and the internal control logic. OE must be driven LOW in order for the device to drive out the requested data. During the second clock, a subsequent operation (Read/Write/Deselect) can be initiated. Deselecting the device is also pipelined. Therefore, when the SRAM is deselected at clock rise by one

of the chip enable signals, its output will three-state following the next clock rise.

Burst Read Accesses

The CY7C1370C and CY7C1372C have an on-chip burst counter that allows the user the ability to supply a single address and conduct up to four Reads without reasserting the address inputs. ADV/LD must be driven LOW in order to load a new address into the SRAM, as described in the Single Read Access section above. The sequence of the burst counter is determined by the MODE input signal. A LOW input on MODE selects a linear burst mode, a HIGH selects an interleaved burst sequence. Both burst counters use A0 and A1 in the burst sequence, and will wrap-around when incremented sufficiently. A HIGH input on ADV/LD will increment the internal burst counter regardless of the state of chip enables inputs or WE. WE is latched at the beginning of a burst cycle. Therefore, the type of access (Read or Write) is maintained throughout the burst sequence.

Single Write Accesses

Write access are initiated when the following conditions are satisfied at clock rise: (1) CEN is asserted LOW, (2) \overline{CE}_1 , \overline{CE}_2 , and \overline{CE}_3 are ALL asserted active, and (3) the write signal WE is asserted LOW. The address presented to A₀–A₁₆ is loaded into the Address Register. The write signals are latched into the Control Logic block.

On the subsequent clock rise the data lines are automatically three-stated regardless of the state of the OE input signal. This allows the external logic to present the data on DQ and DQP ($DQ_{a,b,c,d}/DQP_{a,b,c,d}$ for CY7C1370C and $DQ_{a,b}/DQP_{a,b}$ for CY7C1372C). In addition, the address for the subsequent access (Read/Write/Deselect) is latched into the Address Register (provided the appropriate control signals are asserted).

On the next clock rise the data presented to DQ and DQP ($DQ_{a,b,c,d}/DQP_{a,b,c,d}$ for CY7C1370C & $DQ_{a,b}/DQP_{a,b}$ for CY7C1372C) (or a subset for byte write operations, see Write Cycle Description table for details) inputs is latched into the device and the write is complete.

The data written during the Write operation is controlled by \overline{BW} ($\overline{BW}_{a,b,c,d}$ for CY7C1370C and $\overline{BW}_{a,b}$ for CY7C1372C) signals. The CY7C1370C/CY7C1372C provides byte write capability that is described in the Write Cycle Description table. Asserting the Write Enable input (WE) with the selected Byte Write Select (BW) input will selectively write to only the desired bytes. Bytes not selected during a byte write operation will remain unaltered. A synchronous self-timed write mechanism has been provided to simplify the write operations. Byte write

capability has been included in order to greatly simplify Read/Modify/Write sequences, which can be reduced to simple byte write operations.

Because the CY7C1370C and CY7C1372C are common I/O devices, data should not be driven into the device while the outputs are active. The Output Enable (\overline{OE}) can be deasserted HIGH before presenting data to the DQ and DQP ($DQ_{a,b,c,d}/DQP_{a,b,c,d}$ for CY7C1370C and $DQ_{a,b}/DQP_{a,b}$ for CY7C1372C) inputs. Doing so will three-state the output drivers. As a safety precaution, DQ and DQP ($DQ_{a,b,c,d}/DQP_{a,b,c,d}$ for CY7C1370C and $DQ_{a,b}/DQP_{a,b}$ for CY7C1372C) are automatically three-stated during the data portion of a write cycle, regardless of the state of OE.

Burst Write Accesses

The CY7C1370C/CY7C1372C has an on-chip burst counter that allows the user the ability to supply a single address and conduct up to four WRITE operations without reasserting the address inputs. ADV/LD must be driven LOW in order to load the initial address, as described in the Single Write Access section above. When ADV/LD is driven HIGH on the subsequent clock rise, the chip enables (\overline{CE}_1 , CE_2 , and \overline{CE}_3) and WE inputs are ignored and the burst counter is incremented. The correct BW ($BW_{a,b,c,d}$ for CY7C1370C and $BW_{a,b}$ for CY7C1372C) inputs must be driven in each cycle of the burst write in order to write the correct bytes of data.

Sleep Mode

The ZZ input pin is an asynchronous input. Asserting ZZ places the SRAM in a power conservation “sleep” mode. Two

clock cycles are required to enter into or exit from this “sleep” mode. While in this mode, data integrity is guaranteed. Accesses pending when entering the “sleep” mode are not considered valid nor is the completion of the operation guaranteed. The device must be deselected prior to entering the “sleep” mode. CE_1 , CE_2 , and CE_3 , must remain inactive for the duration of t_{ZZREC} after the ZZ input returns LOW.

Interleaved Burst Address Table (MODE = Floating or V_{DD})

First Address	Second Address	Third Address	Fourth Address
A1,A0	A1,A0	A1,A0	A1,A0
00	01	10	11
01	00	11	10
10	11	00	01
11	10	01	00

Linear Burst Address Table (MODE = GND)

First Address	Second Address	Third Address	Fourth Address
A1,A0	A1,A0	A1,A0	A1,A0
00	01	10	11
01	10	11	00
10	11	00	01
11	00	01	10

ZZ Mode Electrical Characteristics

Parameter	Description	Test Conditions	Min.	Max	Unit
I_{DDZZ}	Snooze mode standby current	$ZZ \geq V_{DD} - 0.2V$		60	mA
t_{ZZS}	Device operation to ZZ	$ZZ \geq V_{DD} - 0.2V$		$2t_{CYC}$	ns
t_{ZZREC}	ZZ recovery time	$ZZ \leq 0.2V$	$2t_{CYC}$		ns
t_{ZZI}	ZZ active to snooze current	This parameter is sampled		$2t_{CYC}$	ns
t_{RZZI}	ZZ Inactive to exit snooze current	This parameter is sampled	0		ns

Truth Table^[1, 2, 3, 4, 5, 6, 7]

Operation	Address Used	\overline{CE}	ZZ	ADV/LD	\overline{WE}	\overline{BW}_x	\overline{OE}	\overline{CEN}	CLK	DQ
Deselect Cycle	None	H	L	L	X	X	X	L	L-H	Three-State
Continue Deselect Cycle	None	X	L	H	X	X	X	L	L-H	Three-State
Read Cycle (Begin Burst)	External	L	L	L	H	X	L	L	L-H	Data Out (Q)
Read Cycle (Continue Burst)	Next	X	L	H	X	X	L	L	L-H	Data Out (Q)
NOP/Dummy Read (Begin Burst)	External	L	L	L	H	X	H	L	L-H	Three-State
Dummy Read (Continue Burst)	Next	X	L	H	X	X	H	L	L-H	Three-State
Write Cycle (Begin Burst)	External	L	L	L	L	L	X	L	L-H	Data In (D)
Write Cycle (Continue Burst)	Next	X	L	H	X	L	X	L	L-H	Data In (D)

Notes:

- X = “Don’t Care”, 1 = Logic HIGH, 0 = Logic LOW, \overline{CE} stands for ALL Chip Enables active. $\overline{BW}_x = 0$ signifies at least one Byte Write Select is active, $\overline{BW}_x = \text{Valid}$ signifies that the desired byte write selects are asserted, see Write Cycle Description table for details.
- Write is defined by WE and $BW_{[a:d]}$. See Write Cycle Description table for details.
- When a write cycle is detected, all I/Os are tri-stated, even during byte writes.
- The DQ and DQP pins are controlled by the current cycle and the OE signal.
- $\overline{CEN} = H$ inserts wait states.
- Device will power-up deselected and the I/Os in a tri-state condition, regardless of \overline{OE} .
- \overline{OE} is asynchronous and is not sampled with the clock rise. It is masked internally during write cycles. During a read cycle DQ_s and $DQP_{[a:d]}$ = Three-state when OE is inactive or when the device is deselected, and DQ_s =data when OE is active.

Truth Table^[1, 2, 3, 4, 5, 6, 7] (continued)

Operation	Address Used	\overline{CE}	ZZ	ADV/LD	\overline{WE}	\overline{BW}_x	\overline{OE}	\overline{CEN}	CLK	DQ
NOP/WRITE ABORT (Begin Burst)	None	L	L	L	L	H	X	L	L-H	Three-State
WRITE ABORT (Continue Burst)	Next	X	L	H	X	H	X	L	L-H	Three-State
IGNORE CLOCK EDGE (Stall)	Current	X	L	X	X	X	X	H	L-H	–
SNOOZE MODE	None	X	H	X	X	X	X	X	X	Three-State

Partial Write Cycle Description^[1, 2, 3, 8]

Function (CY7C1370C)	\overline{WE}	\overline{BW}_d	\overline{BW}_c	\overline{BW}_b	\overline{BW}_a
Read	H	X	X	X	X
Write – No bytes written	L	H	H	H	H
Write Byte a – (DQ _a and DQP _a)	L	H	H	H	L
Write Byte b – (DQ _b and DQP _b)	L	H	H	L	H
Write Bytes b, a	L	H	H	L	L
Write Byte c – (DQ _c and DQP _c)	L	H	L	H	H
Write Bytes c, a	L	H	L	H	L
Write Bytes c, b	L	H	LL	L	H
Write Bytes c, b, a	L	H	L	L	L
Write Byte d – (DQ _d and DQP _d)	L	L	H	H	H
Write Bytes d, a	L	L	H	H	L
Write Bytes d, b	L	L	H	L	H
Write Bytes d, b, a	L	L	H	L	L
Write Bytes d, c	L	L	L	H	H
Write Bytes d, c, a	L	L	L	H	L
Write Bytes d, c, b	L	L	L	L	H
Write All Bytes	L	L	L	L	L

Function (CY7C1372C)	\overline{WE}	\overline{BW}_b	\overline{BW}_a
Read	H	x	x
Write – No Bytes Written	L	H	H
Write Byte a – (DQ _a and DQP _a)	L	H	L
Write Byte b – (DQ _b and DQP _b)	L	L	H
Write Both Bytes	L	L	L

Note:

8. Table only lists a partial listing of the byte write combinations. Any combination of $\overline{BW}_{[a:d]}$ is valid. Appropriate write will be done based on which byte write is active.

IEEE 1149.1 Serial Boundary Scan (JTAG)

The CY7C1370C/CY7C1372C incorporates a serial boundary scan Test Access Port (TAP) in the BGA package only. The TQFP package does not offer this functionality. This port operates in accordance with IEEE Standard 1149.1-1900, but does not have the set of functions required for full 1149.1 compliance. These functions from the IEEE specification are excluded because their inclusion places an added delay in the critical speed path of the SRAM. Note that the TAP controller functions in a manner that does not conflict with the operation of other devices using 1149.1 fully compliant TAPs. The TAP operates using JEDEC standard 3.3V or 2.5V I/O logic levels.

Disabling the JTAG Feature

It is possible to operate the SRAM without using the JTAG feature. To disable the TAP controller, TCK must be tied LOW (V_{SS}) to prevent clocking of the device. TDI and TMS are internally pulled up and may be unconnected. They may alternately be connected to V_{DD} through a pull-up resistor. TDO should be left unconnected. Upon power-up, the device will come up in a reset state which will not interfere with the operation of the device.

Test Access Port–Test Clock

The test clock is used only with the TAP controller. All inputs are captured on the rising edge of TCK. All outputs are driven from the falling edge of TCK.

Test Mode Select

The TMS input is used to give commands to the TAP controller and is sampled on the rising edge of TCK. It is allowable to leave this pin unconnected if the TAP is not used. The pin is pulled up internally, resulting in a logic HIGH level.

Test Data-In (TDI)

The TDI pin is used to serially input information into the registers and can be connected to the input of any of the registers. The register between TDI and TDO is chosen by the instruction that is loaded into the TAP instruction register. For information on loading the instruction register, see the TAP Controller State Diagram. TDI is internally pulled up and can be unconnected if the TAP is unused in an application. TDI is connected to the Most Significant Bit (MSB) on any register.

Test Data Out (TDO)

The TDO output pin is used to serially clock data-out from the registers. The output is active depending upon the current state of the TAP state machine (see TAP Controller State Diagram). The output changes on the falling edge of TCK. TDO is connected to the Least Significant Bit (LSB) of any register.

Performing a TAP Reset

A Reset is performed by forcing TMS HIGH (V_{DD}) for five rising edges of TCK. This RESET does not affect the operation of the SRAM and may be performed while the SRAM is operating. At power-up, the TAP is reset internally to ensure that TDO comes up in a High-Z state.

TAP Registers

Registers are connected between the TDI and TDO pins and allow data to be scanned into and out of the SRAM test

circuitry. Only one register can be selected at a time through the instruction registers. Data is serially loaded into the TDI pin on the rising edge of TCK. Data is output on the TDO pin on the falling edge of TCK.

Instruction Register

Three-bit instructions can be serially loaded into the instruction register. This register is loaded when it is placed between the TDI and TDO pins as shown in the TAP Controller Block Diagram. Upon power-up, the instruction register is loaded with the IDCODE instruction. It is also loaded with the IDCODE instruction if the controller is placed in a reset state as described in the previous section.

When the TAP controller is in the CaptureIR state, the two least significant bits are loaded with a binary “01” pattern to allow for fault isolation of the board level serial test path.

Bypass Register

To save time when serially shifting data through registers, it is sometimes advantageous to skip certain states. The bypass register is a single-bit register that can be placed between TDI and TDO pins. This allows data to be shifted through the SRAM with minimal delay. The bypass register is set LOW (V_{SS}) when the BYPASS instruction is executed.

Boundary Scan Register

The boundary scan register is connected to all the input and output pins on the SRAM. Several no connect (NC) pins are also included in the scan register to reserve pins for higher density devices. The $\times 36$ configuration has a 69-bit-long register, and the $\times 18$ configuration has a 69-bit-long register.

The boundary scan register is loaded with the contents of the RAM Input and Output ring when the TAP controller is in the Capture-DR state and is then placed between the TDI and TDO pins when the controller is moved to the Shift-DR state. The EXTEST, SAMPLE/PRELOAD and SAMPLE Z instructions can be used to capture the contents of the Input and Output ring.

The Boundary Scan Order tables show the order in which the bits are connected. Each bit corresponds to one of the bumps on the SRAM package. The MSB of the register is connected to TDI, and the LSB is connected to TDO.

Identification (ID) Register

The ID register is loaded with a vendor-specific, 32-bit code during the Capture-DR state when the IDCODE command is loaded in the instruction register. The IDCODE is hardwired into the SRAM and can be shifted out when the TAP controller is in the Shift-DR state. The ID register has a vendor code and other information described in the Identification Register Definitions table.

TAP Instruction Set

Eight different instructions are possible with the three-bit instruction register. All combinations are listed in the Instruction Code table. Three of these instructions are listed as RESERVED and should not be used. The other five instructions are described in detail below.

The TAP controller used in this SRAM is not fully compliant to the 1149.1 convention because some of the mandatory 1149.1 instructions are not fully implemented. The TAP controller cannot be used to load address, data, or control signals into

the SRAM and cannot preload the Input or Output buffers. The SRAM does not implement the 1149.1 commands EXTEST or INTEST or the PRELOAD portion of SAMPLE/PRELOAD; rather it performs a capture of the Inputs and Output ring when these instructions are executed.

Instructions are loaded into the TAP controller during the Shift-IR state when the instruction register is placed between TDI and TDO. During this state, instructions are shifted through the instruction register through the TDI and TDO pins. To execute the instruction once it is shifted in, the TAP controller needs to be moved into the Update-IR state.

EXTEST

EXTEST is a mandatory 1149.1 instruction which is to be executed whenever the instruction register is loaded with all 0s. EXTEST is not implemented in the TAP controller, and therefore this device is not compliant to the 1149.1 standard.

The TAP controller does not recognize an all-0 instruction. When an EXTEST instruction is loaded into the instruction register, the SRAM responds as if a SAMPLE/PRELOAD instruction has been loaded. There is one difference between the two instructions. Unlike the SAMPLE/PRELOAD instruction, EXTEST places the SRAM outputs in a High-Z state.

IDCODE

The IDCODE instruction causes a vendor-specific, 32-bit code to be loaded into the instruction register. It also places the instruction register between the TDI and TDO pins and allows the IDCODE to be shifted out of the device when the TAP controller enters the Shift-DR state. The IDCODE instruction is loaded into the instruction register upon power-up or whenever the TAP controller is given a test logic reset state.

SAMPLE Z

The SAMPLE Z instruction causes the boundary scan register to be connected between the TDI and TDO pins when the TAP controller is in a Shift-DR state. It also places all SRAM outputs into a High-Z state.

SAMPLE/PRELOAD

SAMPLE/PRELOAD is a 1149.1 mandatory instruction. The PRELOAD portion of this instruction is not implemented, so the TAP controller is not fully 1149.1-compliant.

When the SAMPLE/PRELOAD instructions are loaded into the instruction register and the TAP controller is in the Capture-DR state, a snapshot of data on the inputs and output pins is captured in the boundary scan register.

The user must be aware that the TAP controller clock can only operate at a frequency up to 10 MHz, while the SRAM clock operates more than an order of magnitude faster. Because there is a large difference in the clock frequencies, it is possible that during the Capture-DR state, an input or output will undergo a transition. The TAP may then try to capture a signal while in transition (metastable state). This will not harm the device, but there is no guarantee as to the value that will be captured. Repeatable results may not be possible.

To guarantee that the boundary scan register will capture the correct value of a signal, the SRAM signal must be stabilized long enough to meet the TAP controller's capture set-up plus hold times (t_{CS} and t_{CH}). The SRAM clock input might not be captured correctly if there is no way in a design to stop (or slow) the clock during a SAMPLE/PRELOAD instruction. If this is an issue, it is still possible to capture all other signals and simply ignore the value of the CK and CK# captured in the boundary scan register.

Once the data is captured, it is possible to shift out the data by putting the TAP into the Shift-DR state. This places the boundary scan register between the TDI and TDO pins.

Note that since the PRELOAD part of the command is not implemented, putting the TAP into the Update-DR state while performing a SAMPLE/PRELOAD instruction will have the same effect as the Pause-DR command.

Bypass

When the BYPASS instruction is loaded in the instruction register and the TAP is placed in a Shift-DR state, the bypass register is placed between the TDI and TDO pins. The advantage of the BYPASS instruction is that it shortens the boundary scan path when multiple devices are connected together on a board.

Reserved

These instructions are not implemented but are reserved for future use. Do not use these instructions.

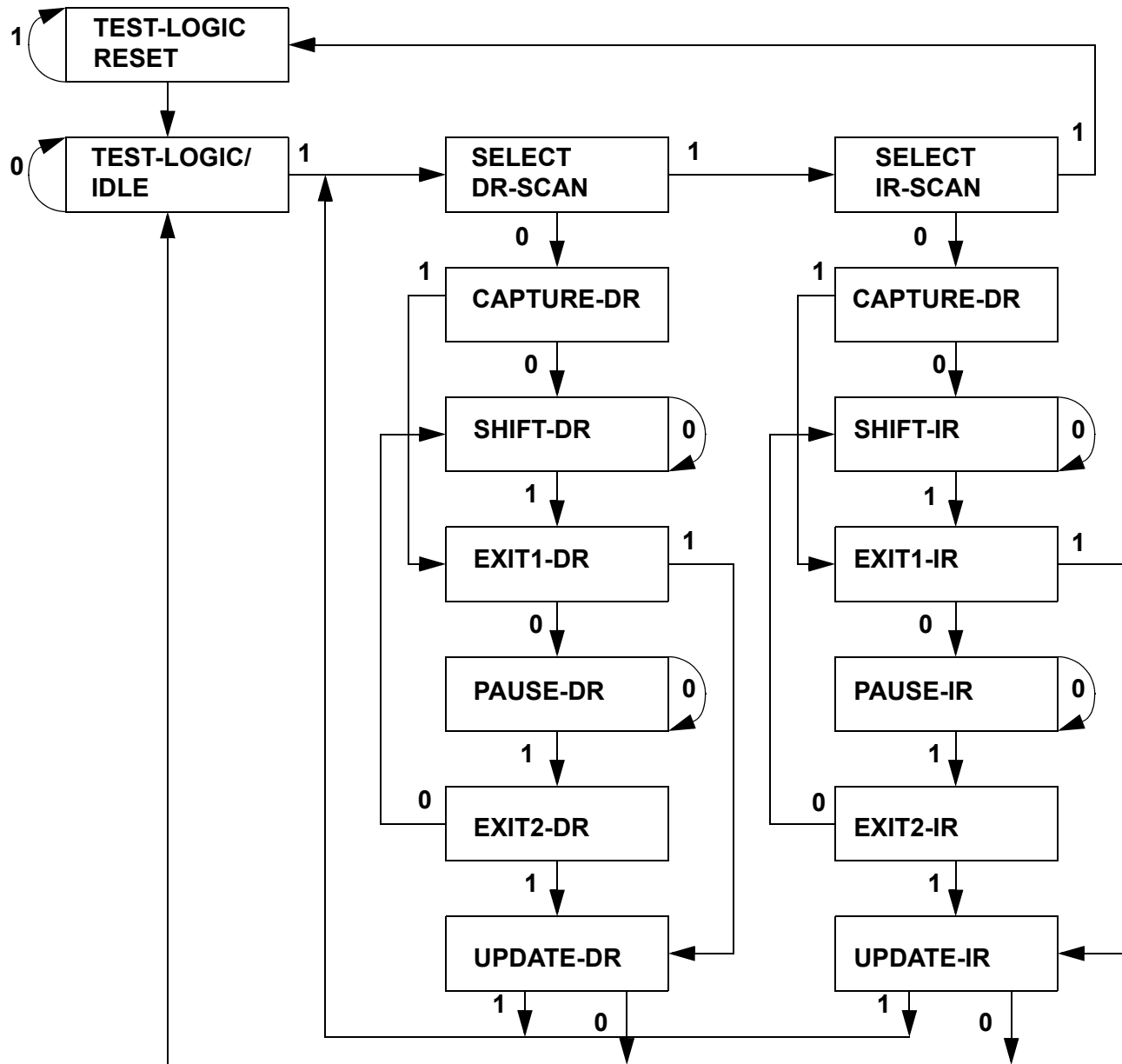
TAP Controller State Diagram^[9]

Note:
9. The 0/1 next to each state represents the value at TMS at the rising edge of TCK.

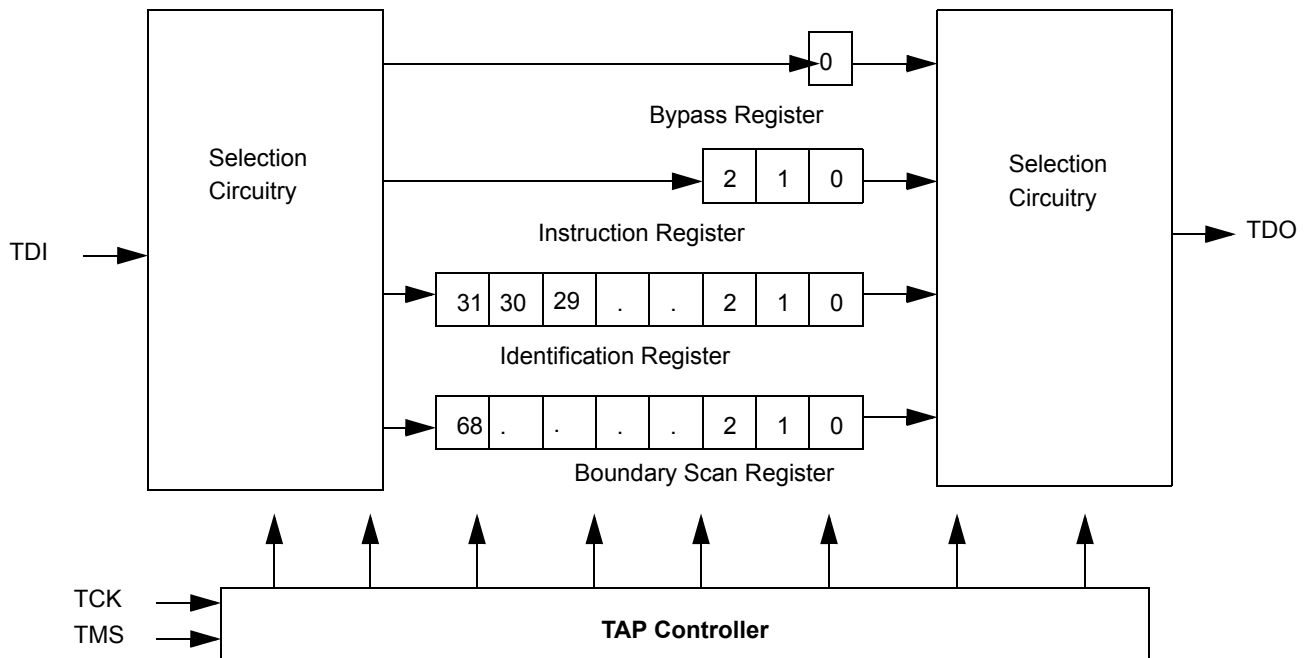
TAP Controller Block Diagram

TAP Electrical Characteristics Over the Operating Range^[10, 11]

Parameter	Description	Test Conditions		Min.	Max.	Unit
V _{OH1}	Output HIGH Voltage	I _{OH} = -4.0 mA	V _{DDQ} = 3.3V	2.4		V
		I _{OH} = -1.0 mA	V _{DDQ} = 2.5V	1.7		
V _{OH2}	Output HIGH Voltage	I _{OH} = -100 μA	V _{DDQ} = 3.3V	2.9		V
			V _{DDQ} = 2.5V	2.1		
V _{OL1}	Output LOW Voltage	I _{OL} = 8.0 mA	V _{DDQ} = 3.3V		0.4	V
		I _{OL} = 1.0 mA	V _{DDQ} = 2.5V		0.4	V
V _{OL2}	Output LOW Voltage	I _{OL} = 100 μA	V _{DDQ} = 3.3V		0.2	V
			V _{DDQ} = 2.5V		0.2	V
V _{IH}	Input HIGH Voltage		V _{DDQ} = 3.3V	2.0	V _{DD} + 0.3	V
			V _{DDQ} = 2.5V	1.7	V _{DD} + 0.3	V
V _{IL}	Input LOW Voltage		V _{DDQ} = 3.3V	-0.5	0.7	V
			V _{DDQ} = 2.5V	-0.3	0.7	V
I _X	Input Load Current	GND ≤ V _I ≤ V _{DDQ}		-5	5	μA
I _X	Input Load Current TMS and TDI	GND ≤ V _I ≤ V _{DDQ}		-5	5	μA

TAP AC Switching Characteristics Over the Operating Range^[12, 13]

Parameter	Description	Min.	Max.	Unit
t _{TCYC}	TCK Clock Cycle Time	100		ns
t _{TF}	TCK Clock Frequency		10	MHz
t _{TH}	TCK Clock HIGH	40		ns
t _{TL}	TCK Clock LOW	40		ns

Notes:

10. All voltage referenced to ground.

11. Overshoot: V_{IH}(AC) ≤ V_{DD} + 1.5V for t ≤ t_{TCYC}/2; undershoot: V_{IL}(AC) ≥ -0.5V for t ≤ t_{TCYC}/2.

12. t_{CS} and t_{CH} refer to the set-up and hold time requirements of latching data from the boundary scan register.

13. Test conditions are specified using the load in TAP AC test conditions. t_r/t_f = 1 ns.

TAP AC Switching Characteristics Over the Operating Range^[12, 13] (continued)

Parameter	Description	Min.	Max.	Unit
Set-up Times				
t_{TMSS}	TMS Set-up to TCK Clock Rise	10		ns
t_{TDIS}	TDI Set-up to TCK Clock Rise	10		ns
t_{CS}	Capture Set-up to TCK Rise	10		ns
Hold Times				
t_{TMSH}	TMS Hold after TCK Clock Rise	10		ns
t_{TDIH}	TDI Hold after Clock Rise	10		ns
t_{CH}	Capture Hold after clock rise	10		ns
Output Times				
t_{TDOV}	TCK Clock LOW to TDO Valid		20	ns
t_{TDOX}	TCK Clock LOW to TDO Invalid	0		ns

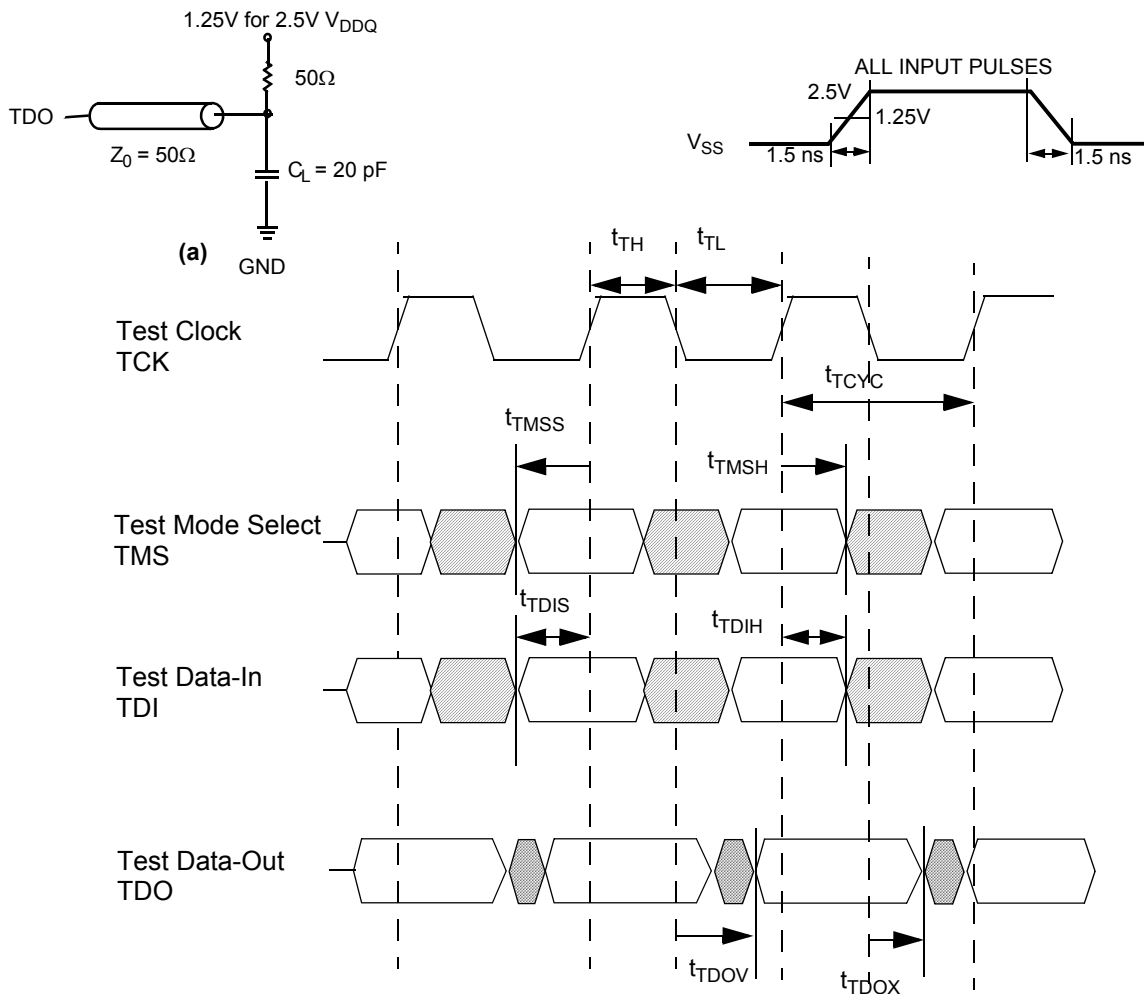
TAP Timing and Test Conditions

Identification Register Definitions

Instruction Field	CY7C1370C	CY7C1372C	Description
Revision Number (31:29)	010	010	Reserved for version number.
Cypress Device ID (28:12)	01010001000100101	01010001000010101	Reserved for future use.
Cypress JEDEC ID (11:1)	00000110100	00000110100	Allows unique identification of SRAM vendor.
ID Register Presence (0)	1	1	Indicate the presence of an ID register.

Scan Register Sizes

Register Name	Bit Size(x18)	Bit Size (x36)
Instruction	3	3
Bypass	1	1
ID	32	32
Boundary Scan	70	70

Identification Codes

Instruction	Code	Description
EXTEST	000	Captures the Input/Output ring contents. Places the boundary scan register between the TDI and TDO. Forces all SRAM outputs to High-Z state. This instruction is not 1149.1-compliant.
IDCODE	001	Loads the ID register with the vendor ID code and places the register between TDI and TDO. This operation does not affect SRAM operation.
SAMPLE Z	010	Captures the Input/Output contents. Places the boundary scan register between TDI and TDO. Forces all SRAM output drivers to a High-Z state.
RESERVED	011	Do Not Use: This instruction is reserved for future use.
SAMPLE/PRELOAD	100	Captures the Input/Output ring contents. Places the boundary scan register between TDI and TDO. Does not affect the SRAM operation. This instruction does not implement 1149.1 preload function and is therefore not 1149.1-compliant.
RESERVED	101	Do Not Use: This instruction is reserved for future use.
RESERVED	110	Do Not Use: This instruction is reserved for future use.
BYPASS	111	Places the bypass register between TDI and TDO. This operation does not affect SRAM operation.



119-ball BGA Boundary Scan Order

CY7C1370C (512K x 36)			
Bit#	Ball ID	Bit#	Ball ID
1	K4	36	P4
2	H4	37	N4
3	M4	38	R6
4	F4	39	T5
5	B4	40	T3
6	A4	41	R2
7	G4	42	R3
8	C6	43	P2
9	A6	44	P1
10	D6	45	N2
11	D7	46	L2
12	E6	47	K1
13	G6	48	N1
14	H7	49	M2
15	E7	50	L1
16	F6	51	K2
17	G7	52	Not Bonded (Preset to 1)
18	H6	53	H1
19	T7	54	G2
20	K7	55	E2
21	L6	56	D1
22	N6	57	H2
23	P7	58	G1
24	K6	59	F2
25	L7	60	E1
26	M6	61	D2
27	N7	62	A5
28	P6	63	A3
29	B5	64	E4
30	B3	65	B2
31	C5	66	L3
32	C3	67	G3
33	C2	68	G5
34	A2	69	L5
35	T4	70	B6

CY7C1372C (1M x 18)			
Bit#	Ball ID	Bit#	Ball ID
1	K4	37	N4
2	H4	38	R6
3	M4	39	T5
4	F4	40	T3
5	B4	36	P4
6	A4	41	R2
7	G4	42	R3

8	C6	43	Not Bonded (Preset to 0)
9	A6	44	Not Bonded (Preset to 0)
10	T6	45	Not Bonded (Preset to 0) Not Bonded (Preset to 0)
11	Not Bonded (Preset to 0)	46	Not Bonded (Preset to 0)
12	Not Bonded (Preset to 0)	47	P2
13	Not Bonded (Preset to 0)	48	N1
14	D6	49	M2
15	E7	50	L1
16	F6	51	K2
17	G7	52	Not Bonded (Preset to 1)
18	H6	53	H1
19	T7	54	G2
20	K7	55	E2
21	L6	56	D1
22	N6	57	Not Bonded (Preset to 0) Not Bonded (Preset to 0)
23	P7	58	Not Bonded (Preset to 0) Not Bonded (Preset to 0)
24	Not Bonded (Preset to 0)	59	Not Bonded (Preset to 0)
25	Not Bonded (Preset to 0) Not Bonded (Preset to 0)	60	Not Bonded (Preset to 0)
26	Not Bonded (Preset to 0) Not Bonded (Preset to 0)	61	Not Bonded (Preset to 0)
27	Not Bonded (Preset to 0)	62	A5
28	Not Bonded (Preset to 0)	63	A3
29	B5	64	E4
30	B3	65	B2
31	C5	66	Not Bonded (Preset to 0)
32	C3	67	G3
33	C2	68	Not Bonded (Preset to 0)
34	A2	69	L5
35	T2	70	B6



165-Ball fBGA Boundary Scan Order

CY7C1370C (512K x 36)			
Bit#	Ball ID	Bit#	Ball ID
1	B6	36	R6
2	B7	37	P6
3	A7	38	R4
4	B8	39	R3
5	A8	40	P4
6	B9	41	P3
7	A9	42	R1
8	B10	43	N1
9	A10	44	L2
10	C11	45	K2
11	E10	46	J2
12	F10	47	M2
13	G10	48	M1
14	D10	49	L1
15	D11	50	K1
16	E11	51	J1
17	F11	52	Not Bonded (Preset to 1)
18	G11	53	G2
19	H11	54	F2
20	J10	55	E2
21	K10	56	D2
22	L10	57	G1
23	M10	58	F1
24	J11	59	E1
25	K11	60	D1
26	L11	61	C1
27	M11	62	A2
28	N11	63	B2
29	R11	64	A3
30	R10	65	B3
31	R9	66	B4
32	R8	67	A4
33	P10	68	A5
34	P9	69	B5
35	P8	70	A6

CY7C1372C (1M x 18)			
Bit#	Ball ID	Bit#	Ball ID
1	B6	36	R6
2	B7	37	P6
3	A7	38	R4
4	B8	39	R3
5	A8	40	P4

CY7C1372C (1M x 18)			
Bit#	Ball ID	Bit#	Ball ID
6	B9	41	P3
7	A9	42	R1
8	B10	43	Not Bonded (Preset to 0)
9	A10	44	Not Bonded (Preset to 0)
10	A11	45	Not Bonded (Preset to 0)
11	Not Bonded (Preset to 0)	46	Not Bonded (Preset to 0)
12	Not Bonded (Preset to 0)	47	N1
13	Not Bonded (Preset to 0)	48	M1
14	Not Bonded (Preset to 0)	49	L1
15	D11	50	K1
16	E11	51	J1
17	F11	52	Not Bonded (Preset to 1)
18	G11	53	G2
19	H11	54	F2
20	J10	55	E2
21	K10	56	D2
22	L10	57	Not Bonded (Preset to 0)
23	M10	58	Not Bonded (Preset to 0)
24	Not Bonded (Preset to 0)	59	Not Bonded (Preset to 0)
25	Not Bonded (Preset to 0)	60	Not Bonded (Preset to 0)
26	Not Bonded (Preset to 0)	61	Not Bonded (Preset to 0)
27	Not Bonded (Preset to 0)	62	A2
28	Not Bonded (Preset to 0)	63	B2
29	R11	64	A3
30	R10	65	B3
31	R9	66	Not Bonded (Preset to 0)
32	R8	67	Not Bonded (Preset to 0)
33	P10	68	A4
34	P9	69	B5
35	P8	70	A6



Maximum Ratings

(Above which the useful life may be impaired. For user guidelines, not tested.)

Storage Temperature -65°C to +150°C
 Ambient Temperature with Power Applied..... -55°C to +125°C
 Supply Voltage on V_{DD} Relative to GND..... -0.5V to +4.6V
 DC to Outputs in Tri-State -0.5V to V_{DDQ} + 0.5V
 DC Input Voltage..... -0.5V to V_{DD} + 0.5V

Current into Outputs (LOW)..... 20 mA
 Static Discharge Voltage..... > 2001V (per MIL-STD-883, Method 3015)
 Latch-up Current..... > 200 mA

Operating Range

Range	Ambient Temperature	V _{DD}	V _{DDQ}
Commercial	0°C to +70°C	3.3V-5%/+10%	2.5V -5% to V _{DD}
Industrial	-40°C to +85°C		

Electrical Characteristics Over the Operating Range^[14, 15]

Parameter	Description	Test Conditions	Min.	Max.	Unit
V _{DD}	Power Supply Voltage		3.135	3.6	V
V _{DDQ}	I/O Supply Voltage	V _{DDQ} = 3.3V	3.135	V _{DD}	V
		V _{DDQ} = 2.5V	2.375	2.625	V
V _{OH}	Output HIGH Voltage	V _{DD} = Min., I _{OH} = -4.0 mA, V _{DDQ} = 3.3V	2.4		V
		V _{DD} = Min., I _{OH} = -1.0 mA, V _{DDQ} = 2.5V	2.0		V
V _{OL}	Output LOW Voltage	V _{DD} = Min., I _{OL} = 8.0 mA, V _{DDQ} = 3.3V		0.4	V
		V _{DD} = Min., I _{OL} = 1.0 mA, V _{DDQ} = 2.5V		0.4	V
V _{IH}	Input HIGH Voltage	V _{DDQ} = 3.3V	2.0	V _{DD} + 0.3V	V
		V _{DDQ} = 2.5V	1.7	V _{DD} + 0.3V	V
V _{IL}	Input LOW Voltage ^[14]	V _{DDQ} = 3.3V	-0.3	0.8	V
		V _{DDQ} = 2.5V	-0.3	0.7	V
I _X	Input Load Current	GND ≤ V _I ≤ V _{DDQ}	-5	5	μA
	Input Current of MODE		-30	30	μA
I _{OZ}	Output Leakage Current	GND ≤ V _I ≤ V _{DDQ} , Output Disabled	-5	5	μA
I _{DD}	V _{DD} Operating Supply	V _{DD} = Max., I _{OUT} = 0 mA, f = f _{MAX} = 1/t _{CYC}	4.0-ns cycle, 250 MHz	350	mA
			4.4-ns cycle, 225 MHz	325	mA
			5.0-ns cycle, 200 MHz	300	mA
			6.0-ns cycle, 167 MHz	275	mA
I _{SB1}	Automatic CE Power-down Current—TTL Inputs	Max. V _{DD} , Device Deselected, V _{IN} ≥ V _{IH} or V _{IN} ≤ V _{IL} , f = f _{MAX} = 1/t _{CYC}	4.0-ns cycle, 250 MHz	120	mA
			4.4-ns cycle, 225 MHz	110	mA
			5.0-ns cycle, 200 MHz	100	mA
			6.0-ns cycle, 167 MHz	90	mA
I _{SB2}	Automatic CE Power-down Current—CMOS Inputs	Max. V _{DD} , Device Deselected, V _{IN} ≤ 0.3V or V _{IN} ≥ V _{DDQ} - 0.3V, f = 0	All speed grades	70	mA
I _{SB3}	Automatic CE Power-down Current—CMOS Inputs	Max. V _{DD} , Device Deselected, V _{IN} ≤ 0.3V or V _{IN} ≥ V _{DDQ} - 0.3V, f = f _{MAX} = 1/t _{CYC}	4.0-ns cycle, 250 MHz	105	mA
			4.4-ns cycle, 225 MHz	100	mA
			5.0-ns cycle, 200 MHz	95	mA
			6.0-ns cycle, 167 MHz	85	mA
I _{SB4}	Automatic CE Power-down Current—TTL Inputs	Max. V _{DD} , Device Deselected, V _{IN} ≥ V _{IH} or V _{IN} ≤ V _{IL} , f = 0	All speed grades	80	mA

Shaded areas contain advance information.

Notes:

- 14. Overshoot: V_{IH}(AC) < V_{DD} + 1.5V (Pulse width less than tcyc/2), undershoot: V_{IL}(AC) > -2V (Pulse width less than tcyc/2).
- 15. T_{Power-up}: Assumes a linear ramp from 0V to V_{DD} (min.) within 200ms. During this time V_{IH} < V_{DD} and V_{DDQ} < V_{DD}.

Capacitance^[16]

Parameter	Description	Test Conditions	BGA Max.	fBGA Max.	TQFP Max.	Unit
C _{IN}	Input Capacitance	T _A = 25°C, f = 1 MHz, V _{DD} = 2.5V V _{DDQ} = 2.5V	8	9	5	pF
C _{CLK}	Clock Input Capacitance		8	9	5	pF
C _{I/O}	Input/Output Capacitance		8	9	5	pF

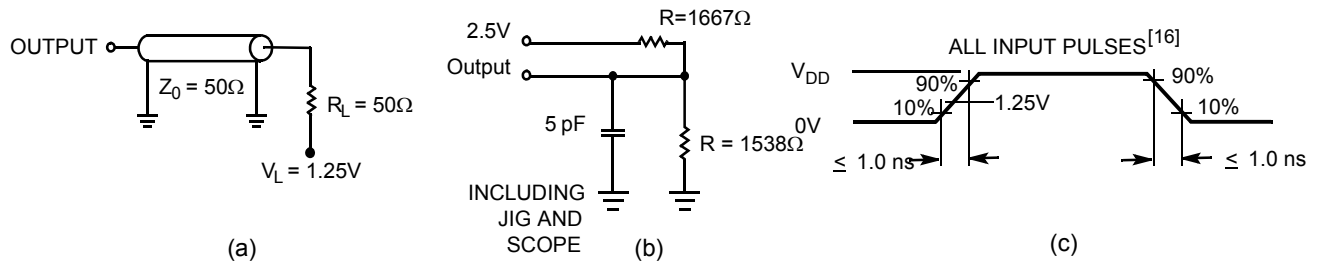
AC Test Loads and Waveforms

Thermal Resistance^[16]

Parameters	Description	Test Conditions	BGA Typ.	fBGA Typ.	TQFP Typ.	Unit	Notes
Q _{JA}	Thermal Resistance (Junction to Ambient)	Test conditions follow standard test methods and procedures for measuring thermal impedance, per EIA / JESD51.	45	46	31	°C/W	17
Q _{JC}	Thermal Resistance (Junction to Case)		7	3	6	°C/W	17

Switching Characteristics Over the Operating Range^[21, 22]

Parameter	Description	-250		-225		-200		-167		Unit
		Min.	Max.	Min.	Max.	Min.	Max.	Min.	Max.	
t _{Power} ^[17]	V _{CC} (typical) to the first access read or write	1		1		1		1		ms
Clock										
t _{CYC}	Clock Cycle Time	4.0		4.4		5		6		ns
F _{MAX}	Maximum Operating Frequency		250		225		200		166	MHz
t _{CH}	Clock HIGH	1.7		2.0		2.0		2.2		ns
t _{CL}	Clock LOW	1.7		2.0		2.0		2.2		ns
Output Times										
t _{CO}	Data Output Valid After CLK Rise		2.6		2.8		3.0		3.4	ns
t _{EOV}	OE LOW to Output Valid		2.6		2.8		3.0		3.4	ns
t _{DOH}	Data Output Hold After CLK Rise	1.0		1.0		1.3		1.3		ns
t _{CHZ}	Clock to High-Z ^[18, 19, 20]		2.6		2.8		3.0		3.4	ns
t _{CLZ}	Clock to Low-Z ^[18, 19, 20]	1.0		1.0		1.3		1.3		ns
t _{EOHZ}	OE HIGH to Output High-Z ^[18, 19, 20]		2.6		2.8		3.0		3.4	ns
t _{EOLZ}	OE LOW to Output Low-Z ^[18, 19, 20]	0		0		0		0		ns

Shaded areas contain advance information.

Notes:

- Tested initially and after any design or process changes that may affect these parameters.
- This part has a voltage regulator internally; t_{power} is the time power needs to be supplied above V_{dd} minimum initially, before a Read or Write operation can be initiated.
- t_{CHZ}, t_{CLZ}, t_{EOLZ}, and t_{EOHZ} are specified with AC test conditions shown in (b) of AC Test Loads. Transition is measured ± 200 mV from steady-state voltage.
- At any given voltage and temperature, t_{EOHZ} is less than t_{EOLZ} and t_{CHZ} is less than t_{CLZ} to eliminate bus contention between SRAMs when sharing the same data bus. These specifications do not imply a bus contention condition, but reflect parameters guaranteed over worst case user conditions. Device is designed to achieve High-Z prior to Low-Z under the same system conditions.
- This parameter is sampled and not 100% tested.
- Timing reference is 1.5V when V_{DDQ}=3.3V and is 1.25V when V_{DDQ}=2.5V.
- Test conditions shown in (a) of AC Test Loads unless otherwise noted.

Switching Characteristics Over the Operating Range [21, 22] (continued)

Parameter	Description	-250		-225		-200		-167		Unit
		Min.	Max.	Min.	Max.	Min.	Max.	Min.	Max.	
Set-up Times										
t_{AS}	Address Set-up Before CLK Rise	1.2		1.4		1.4		1.5		ns
t_{DS}	Data Input Set-up Before CLK Rise	1.2		1.4		1.4		1.5		ns
t_{CENS}	\overline{CEN} Set-up Before CLK Rise	1.2		1.4		1.4		1.5		ns
t_{WES}	\overline{WE} , \overline{BW}_x Set-up Before CLK Rise	1.2		1.4		1.4		1.5		ns
t_{ALS}	$\overline{ADV/LD}$ Set-up Before CLK Rise	1.2		1.4		1.4		1.5		ns
t_{CES}	Chip Select Set-up	1.2		1.4		1.4		1.5		ns
Hold Times										
t_{AH}	Address Hold After CLK Rise	0.3		0.4		0.4		0.5		ns
t_{DH}	Data Input Hold After CLK Rise	0.3		0.4		0.4		0.5		ns
t_{CENH}	\overline{CEN} Hold After CLK Rise	0.3		0.4		0.4		0.5		ns
t_{WEH}	\overline{WE} , \overline{BW}_x Hold After CLK Rise	0.3		0.4		0.4		0.5		ns
t_{ALH}	$\overline{ADV/LD}$ Hold after CLK Rise	0.3		0.4		0.4		0.5		ns
t_{CEH}	Chip Select Hold After CLK Rise	0.3		0.4		0.4		0.5		ns

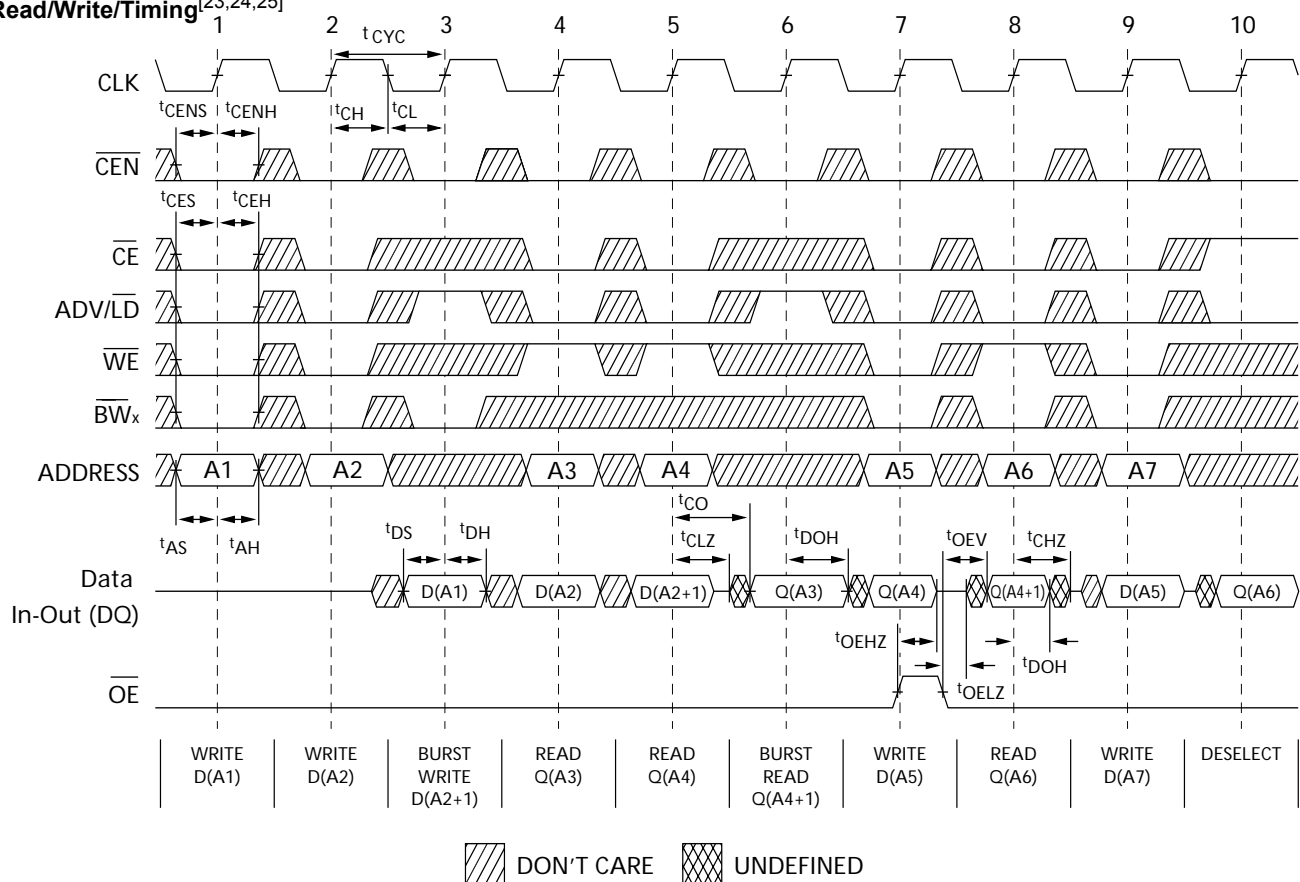
Switching Waveforms
Read/Write/Timing [23,24,25]

Notes:

 23. For this waveform \overline{ZZ} is tied low.

 24. When \overline{CE} is LOW, \overline{CE}_1 is LOW, \overline{CE}_2 is HIGH and \overline{CE}_3 is LOW. When \overline{CE} is HIGH, \overline{CE}_1 is HIGH or \overline{CE}_2 is LOW or \overline{CE}_3 is HIGH.

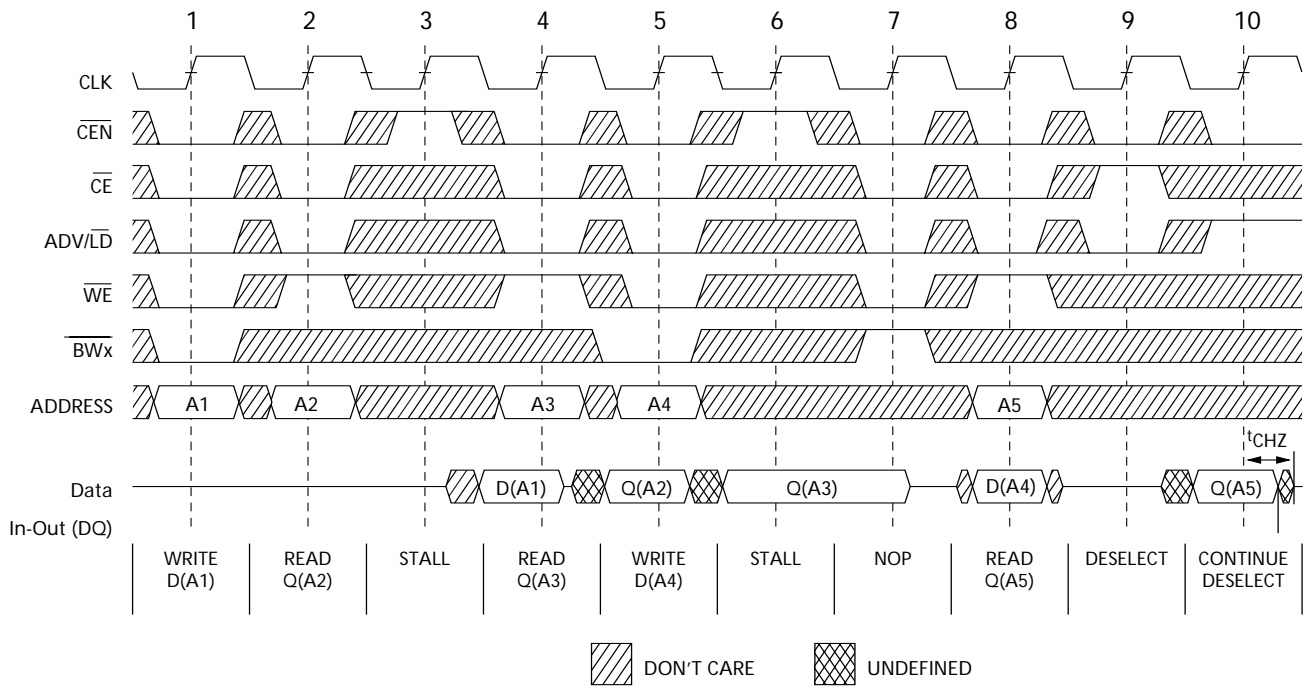
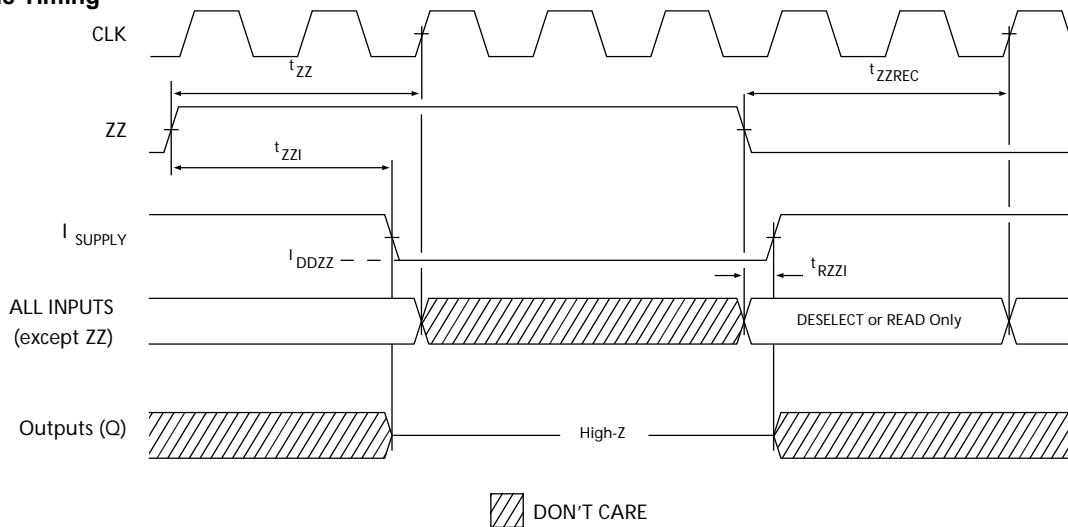
25. Order of the Burst sequence is determined by the status of the MODE (0=Linear, 1=Interleaved). Burst operations are optional.

Switching Waveforms (continued)
NOP, STALL AND DESELECT CYCLES^[23,24,26]

ZZ Mode Timing^[27,28]

Notes:

- 26. The IGNORE CLOCK EDGE or STALL cycle (Clock 3) illustrated \overline{CEN} being used to create a pause. A write is not performed during this cycle
- 27. Device must be deselected when entering ZZ mode. See cycle description table for all possible signal conditions to deselect the device.
- 28. I/Os are in High-Z when exiting ZZ sleep mode.

Ordering Information

Speed (MHz)	Ordering Code	Package Name	Package Type	Operating Range
250	CY7C1370C-250AC	A101	100-lead Thin Quad Flat Pack (14 x 20 x 1.4 mm)	Commercial
	CY7C1372C-250AC			
	CY7C1370C-250BGC	BG119	119-ball Ball Grid Array (14 x 22 x 2.4 mm)	
	CY7C1372C-250BGC			
	CY7C1370C-250BZC	BB165A	165-ball Fine Pitch Ball Grid Array (13 x 15 x 1.2 mm)	
	CY7C1372C-250BZC			
225	CY7C1370C-225AC	A101	100-lead Thin Quad Flat Pack (14 x 20 x 1.4 mm)	Commercial
	CY7C1372C-225AC			
	CY7C1370C-225BGC	BG119	119-ball Ball Grid Array (14 x 22 x 2.4 mm)	
	CY7C1372C-225BGC			
	CY7C1370C-225BZC	BB165A	165-ball Fine Pitch Ball Grid Array (13 x 15 x 1.2 mm)	
	CY7C1372C-225BZC			
200	CY7C1370C-200AC	A101	100-lead Thin Quad Flat Pack (14 x 20 x 1.4 mm)	Commercial
	CY7C1372C-200AC			
	CY7C1370C-200BGC	BG119	119-ball Ball Grid Array (14 x 22 x 2.4 mm)	
	CY7C1372C-200BGC			
	CY7C1370C-200BZC	BB165A	165-ball Fine Pitch Ball Grid Array (13 x 15 x 1.2 mm)	
	CY7C1372C-200BZC			
167	CY7C1370C-167AC	A101	100-lead Thin Quad Flat Pack (14 x 20 x 1.4 mm)	Commercial
	CY7C1372C-167AC			
	CY7C1370C-167BGC	BG119	119-ball Ball Grid Array (14 x 22 x 2.4 mm)	
	CY7C1372C-167BGC			
	CY7C1370C-167BZC	BB165A	165-ball Fine Pitch Ball Grid Array (13 x 15 x 1.2 mm)	
	CY7C1372C-167BZC			

Ordering Information (continued)

Speed (MHz)	Ordering Code	Package Name	Package Type	Operating Range
250	CY7C1370C-250AI	A101	100-lead Thin Quad Flat Pack (14 x 20 x 1.4 mm)	Industrial
	CY7C1372C-250AI			
	CY7C1370C-250BGI	BG119	119-ball Ball Grid Array (14 x 22 x 2.4 mm)	
	CY7C1372C-250BGI			
	CY7C1370C-250BZI	BB165A	165-ball Fine Pitch Ball Grid Array (13 x 15 x 1.2 mm)	
	CY7C1372C-250BZI			
225	CY7C1370C-225AI	A101	100-lead Thin Quad Flat Pack (14 x 20 x 1.4 mm)	Industrial
	CY7C1372C-225AI			
	CY7C1370C-225BGI	BG119	119-ball Ball Grid Array (14 x 22 x 2.4 mm)	
	CY7C1372C-225BGI			
	CY7C1370C-225BZI	BB165A	165-ball Fine Pitch Ball Grid Array (13 x 15 x 1.2 mm)	
	CY7C1372C-225BZI			
200	CY7C1370C-200AI	A101	100-lead Thin Quad Flat Pack (14 x 20 x 1.4 mm)	Industrial
	CY7C1372C-200AI			
	CY7C1370C-200BGI	BG119	119-ball Ball Grid Array (14 x 22 x 2.4 mm)	
	CY7C1372C-200BGI			
	CY7C1370C-200BZI	BB165A	165-ball Fine Pitch Ball Grid Array (13 x 15 x 1.2 mm)	
	CY7C1372C-200BZI			
167	CY7C1370C-167AI	A101	100-lead Thin Quad Flat Pack (14 x 20 x 1.4 mm)	Industrial
	CY7C1372C-167AI			
	CY7C1370C-167BGI	BG119	119-ball Ball Grid Array (14 x 22 x 2.4 mm)	
	CY7C1372C-167BGI			
	CY7C1370C-167BZI	BB165A	165-ball Fine Pitch Ball Grid Array (13 x 15 x 1.2 mm)	
	CY7C1372C-167BZI			

Shaded areas contain advance information. Please contact your local Cypress sales representative for availability of these parts.

Package Diagrams

100-Pin Thin Plastic Quad Flatpack (14 x 20 x 1.4 mm) A101

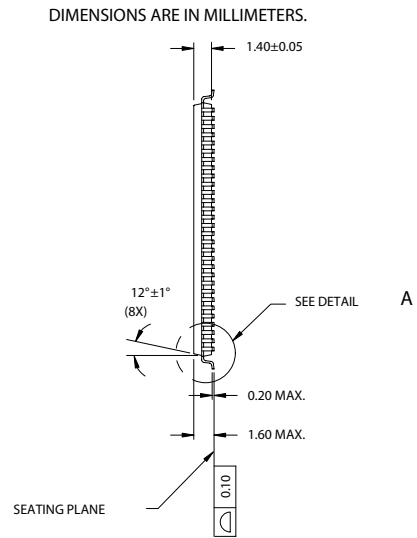
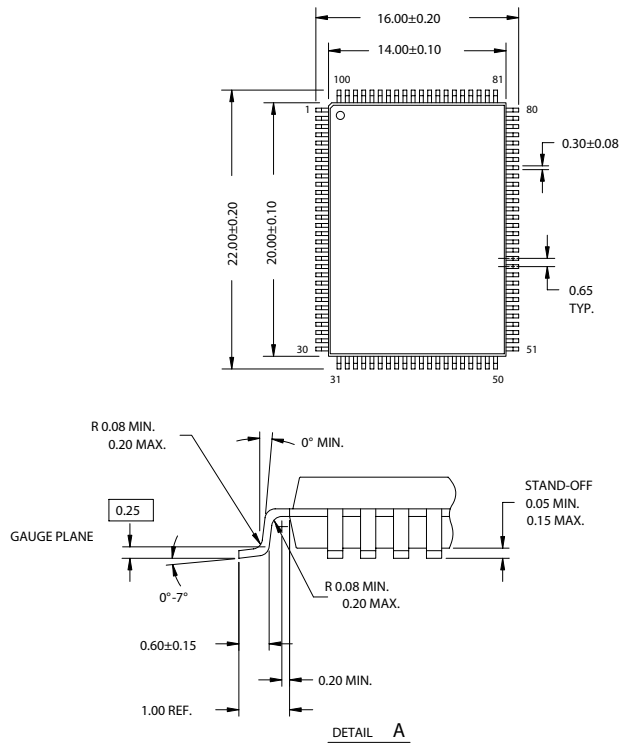

51-85050-*A

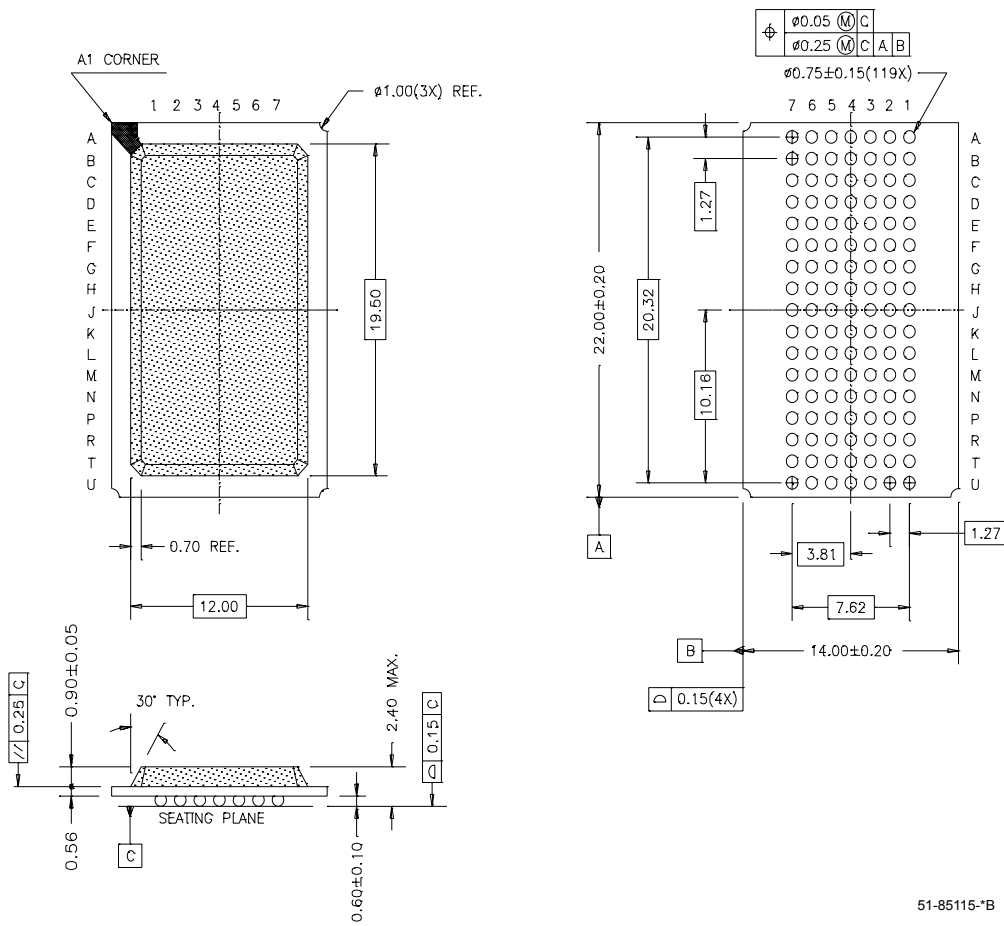
Package Diagrams (continued)

51-85115-B

Package Diagrams (continued)

165-Ball FBGA (13 x 15 x 1.2 mm) BB165A

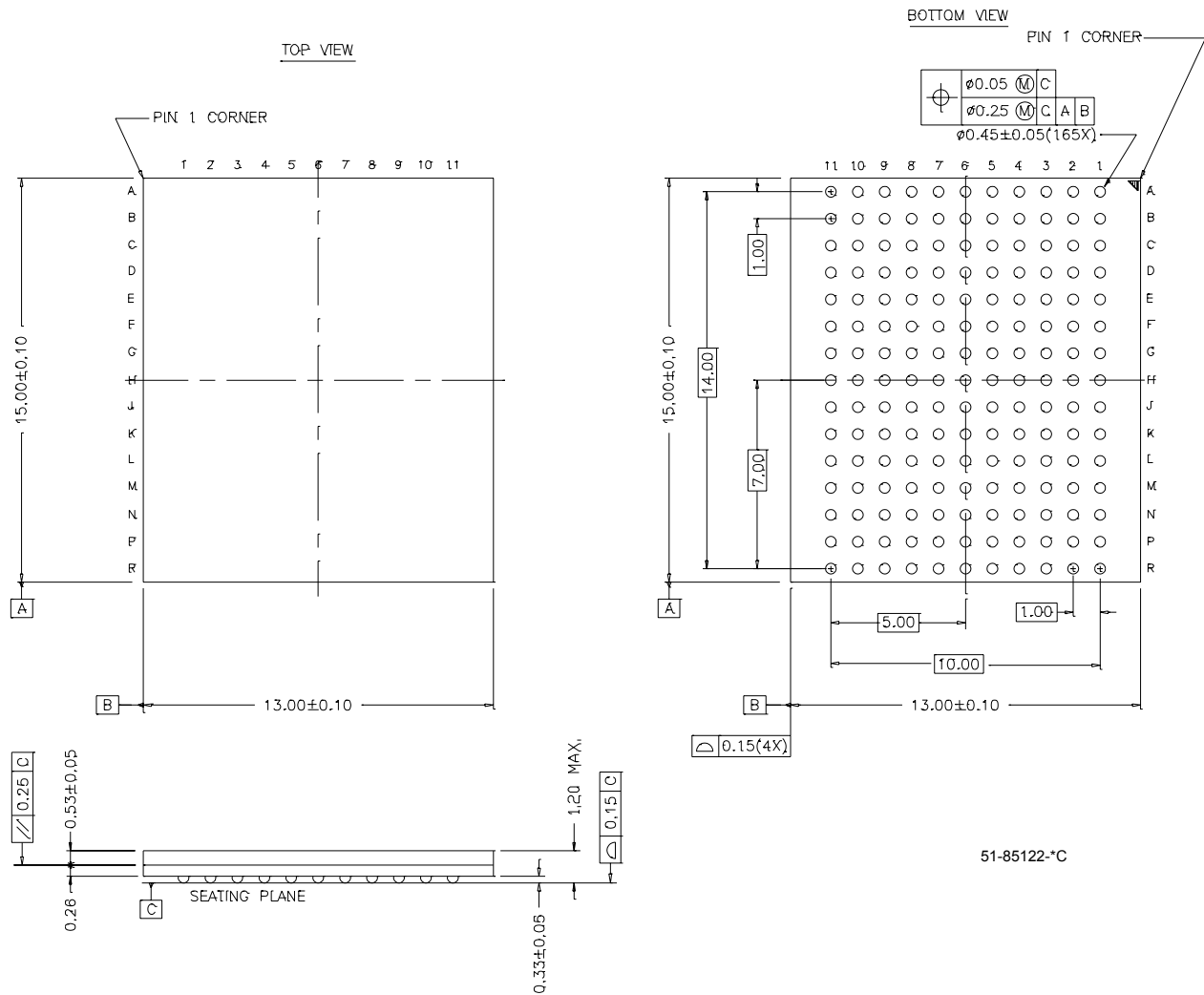

ZBT is a registered trademark of Integrated Device Technology. No Bus Latency and NoBL are trademarks of Cypress Semiconductor. All product and company names mentioned in this document are trademarks of their respective holders.

Document History Page

Document Title: CY7C1370C/CY7C1372C 512K x 36/1M x 18 Pipelined SRAM with NoBL™ Architecture				
Document Number: 38-05233				
REV.	ECN No.	Issue Date	Orig. of Change	Description of Change
**	116273	08/27/02	SKX	New Data Sheet
*A	121536	11/21/02	DSG	Updated package diagrams 51-85115 (BG119) to rev. *B and 51-85122 (BB165A) to rev. *C
*B	206100	see ECN	RKF	Final Data Sheet
*C	225487	See ECN	VBL	Update Ordering Info section: unshade active part numbers
*D	231349	See ECN	DIM	Pin H2 (165 fBGA) changed from NC to NC/V _{DD} .



LittleDiode supplies new, hard to find or obsolete electronic components and semiconductors all over the world.

With over two million different components listed you are sure to find the part you need.

Feel free to visit us today at our online store:

LittleDiode.com

Looking forward to providing you with the best possible service.