



CY7C1381D
CY7C1383D
CY7C1383F

18-Mbit (512 K × 36/1 M × 18) Flow-Through SRAM

Features

- Supports 133 MHz bus operations
- 512 K × 36 and 1 M × 18 common I/O
- 3.3 V core power supply (V_{DD})
- 2.5 V or 3.3 V I/O supply (V_{DDQ})
- Fast clock-to-output time
 - 6.5 ns (133 MHz version)
- Provides high performance 2-1-1 access rate
- User selectable burst counter supporting Intel Pentium interleaved or linear burst sequences
- Separate processor and controller address strobes
- Synchronous self-timed write
- Asynchronous output enable
- CY7C1381D available in JEDEC-standard Pb-free 100-pin TQFP, Pb-free and non Pb-free 165-ball FBGA package. CY7C1383D available in JEDEC-standard Pb-free 100-pin TQFP. CY7C1383F available in non Pb-free 165-ball FBGA package.
- IEEE 1149.1 JTAG-Compatible Boundary Scan
- ZZ sleep mode option

Functional Description

The CY7C1381D/CY7C1383D/CY7C1383F is a 3.3 V, 512 K × 36 and 1 M × 18 synchronous flow through SRAMs, designed to interface with high speed microprocessors with minimum glue logic. Maximum access delay from clock rise is 6.5 ns (133 MHz version). A 2-bit on-chip counter captures the first address in a burst and increments the address automatically for the rest of the burst access. All synchronous inputs are gated by registers controlled by a positive edge triggered clock input (CLK). The synchronous inputs include all addresses, all data inputs, address pipelining chip enable (CE_1), depth-expansion chip enables (CE_2 and CE_3), burst control inputs (ADSC, ADSP, and ADV), write enables (BW_x , and BWE), and global write (GW). Asynchronous inputs include the output enable (OE) and the ZZ pin.

The CY7C1381D/CY7C1383D/CY7C1383F allows interleaved or linear burst sequences, selected by the MODE input pin. A HIGH selects an interleaved burst sequence, while a LOW selects a linear burst sequence. Burst accesses can be initiated with the processor address strobe (ADSP) or the cache controller address strobe (ADSC) inputs. Address advancement is controlled by the address advancement (ADV) input.

Addresses and chip enables are registered at rising edge of clock when address strobe processor (ADSP) or address strobe controller (ADSC) are active. Subsequent burst addresses can be internally generated as controlled by the advance pin (ADV).

CY7C1381D/CY7C1383D/CY7C1383F operates from a +3.3 V core power supply while all outputs operate with a +2.5 V or +3.3 V supply. All inputs and outputs are JEDEC-standard and JESD8-5-compatible.

Selection Guide

| Description | 133 MHz | 100 MHz | Unit |
|------------------------------|---------|---------|------|
| Maximum Access Time | 6.5 | 8.5 | ns |
| Maximum Operating Current | 210 | 175 | mA |
| Maximum CMOS Standby Current | 70 | 70 | mA |

Errata: For information on silicon errata, see "Errata" on page 32. Details include trigger conditions, devices affected, and proposed workaround.

Logic Block Diagram – CY7C1381D

(512 K × 36) [1]

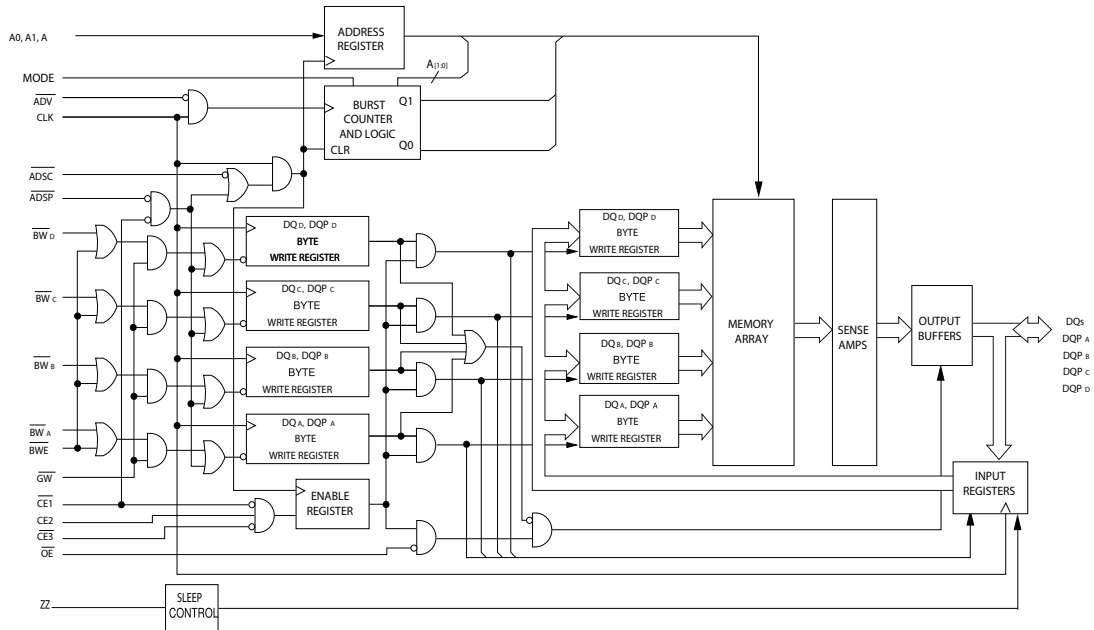

Logic Block Diagram – CY7C1383D/CY7C1383F

(1 M × 18) [1]

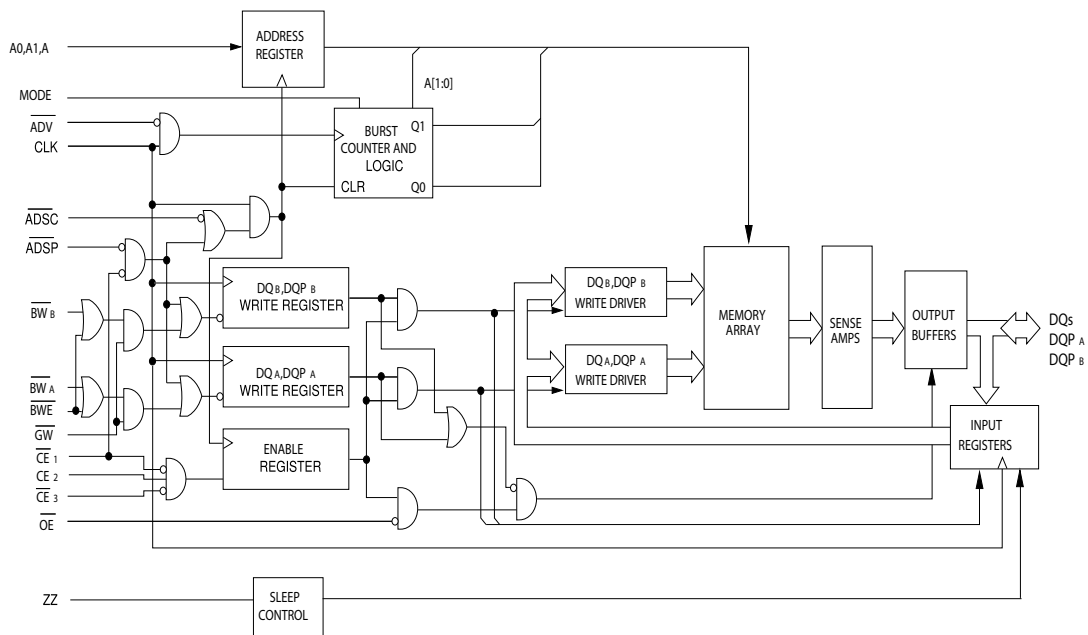

Note

1. CY7C1383F have only 1 chip enable (\overline{CE}_1).

Contents

| | | | |
|---|-----------|--|-----------|
| Pin Configurations | 4 | Scan Register Sizes | 18 |
| Pin Definitions | 6 | Instruction Codes | 18 |
| Functional Overview | 8 | Boundary Scan Order | 19 |
| Single Read Accesses | 8 | Maximum Ratings | 20 |
| Single Write Accesses Initiated by $\overline{\text{ADSP}}$ | 8 | Operating Range | 20 |
| Single Write Accesses Initiated by ADSC | 8 | Neutron Soft Error Immunity | 20 |
| Burst Sequences | 8 | Electrical Characteristics | 20 |
| Sleep Mode | 8 | Capacitance | 21 |
| Interleaved Burst Address Table | 9 | Thermal Resistance | 21 |
| Linear Burst Address Table | 9 | AC Test Loads and Waveforms | 22 |
| ZZ Mode Electrical Characteristics | 9 | Switching Characteristics | 23 |
| Truth Table | 10 | Timing Diagrams | 24 |
| Truth Table for Read/Write | 11 | Ordering Information | 28 |
| Truth Table for Read/Write | 11 | Ordering Code Definitions | 28 |
| IEEE 1149.1 Serial Boundary Scan (JTAG [14]) | 12 | Package Diagrams | 29 |
| Disabling the JTAG Feature | 12 | Acronyms | 31 |
| Test Access Port (TAP) | 12 | Document Conventions | 31 |
| PERFORMING A TAP RESET | 12 | Units of Measure | 31 |
| TAP REGISTERS | 12 | Errata | 32 |
| TAP Instruction Set | 13 | Part Numbers Affected | 32 |
| TAP Controller State Diagram | 14 | Product Status | 32 |
| TAP Controller Block Diagram | 15 | Ram9 Sync ZZ Pin & JTAG Issues | |
| TAP Timing | 16 | Errata Summary | 32 |
| TAP AC Switching Characteristics | 16 | Document History Page | 34 |
| 3.3 V TAP AC Test Conditions | 17 | Sales, Solutions, and Legal Information | 37 |
| 3.3 V TAP AC Output Load Equivalent | 17 | Worldwide Sales and Design Support | 37 |
| 2.5 V TAP AC Test Conditions | 17 | Products | 37 |
| 2.5 V TAP AC Output Load Equivalent | 17 | PSoC® Solutions | 37 |
| TAP DC Electrical Characteristics and | | Cypress Developer Community | 37 |
| Operating Conditions | 17 | Technical Support | 37 |
| Identification Register Definitions | 18 | | |

Pin Configurations

Figure 1. 100-pin TQFP (14 × 20 × 1.4 mm) pinout (3 Chip Enable) [2]

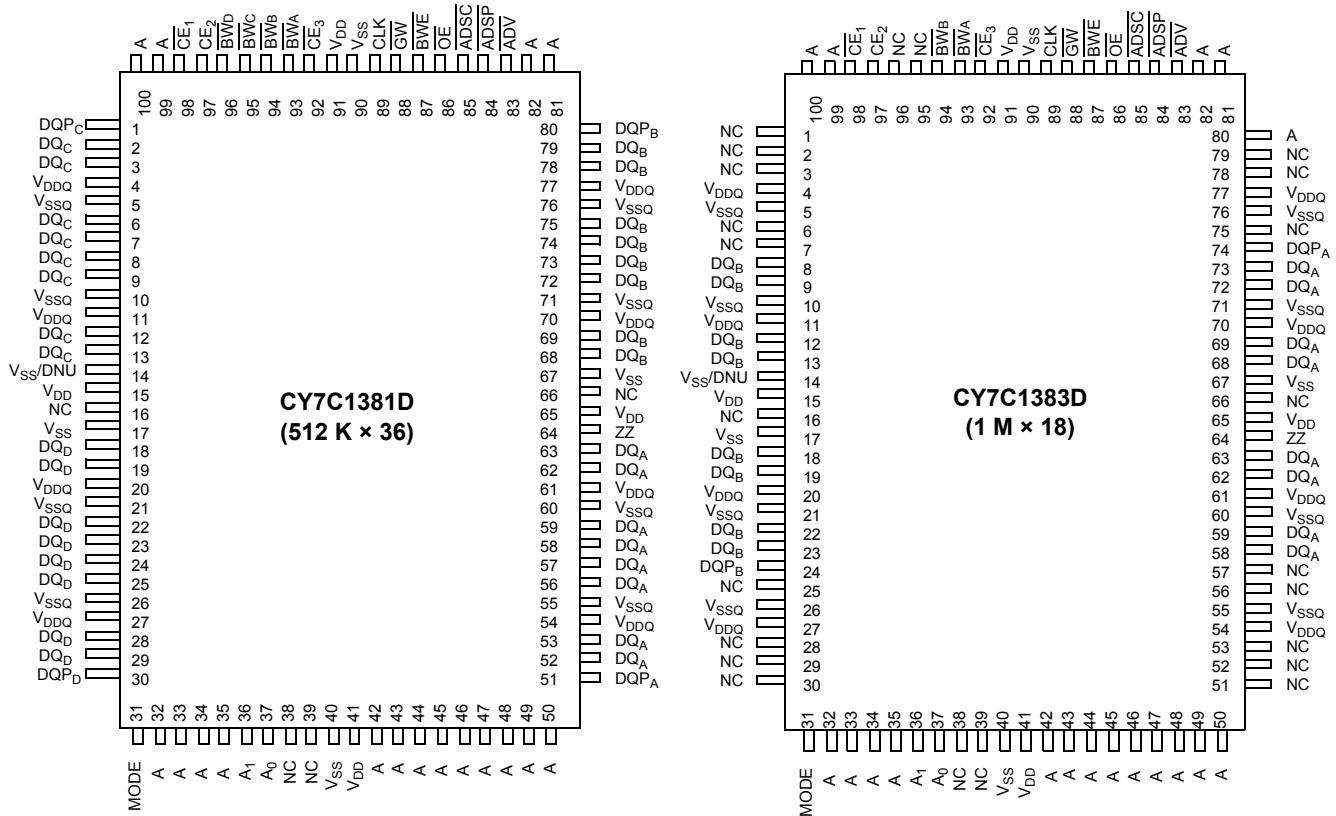

Note

2. **Errata:** The ZZ pin (Pin 64) needs to be externally connected to ground. For more information, see "Errata" on page 32.

Pin Configurations (continued)

Figure 2. 165-ball FBGA (13 × 15 × 1.4 mm) pinout(3 Chip Enable) [3, 4]

CY7C1381D (512 K × 36)

| | 1 | 2 | 3 | 4 | 5 | 6 | 7 | 8 | 9 | 10 | 11 |
|----------|------------------|-----------------|-------------------|-------------------|-------------------|-------------------|------------------|-------------------|-------------------|-----------------|------------------|
| A | NC/288M | A | \overline{CE}_1 | \overline{BW}_C | \overline{BW}_B | \overline{CE}_3 | \overline{BWE} | \overline{ADSC} | \overline{ADV} | A | NC |
| B | NC/144M | A | CE_2 | \overline{BW}_D | \overline{BW}_A | CLK | \overline{GW} | \overline{OE} | \overline{ADSP} | A | NC/576M |
| C | DQP _C | NC | V _{DDQ} | V _{SS} | V _{SS} | V _{SS} | V _{SS} | V _{SS} | V _{DDQ} | NC/1G | DQP _B |
| D | DQ _C | DQ _C | V _{DDQ} | V _{DD} | V _{SS} | V _{SS} | V _{SS} | V _{DD} | V _{DDQ} | DQ _B | DQ _B |
| E | DQ _C | DQ _C | V _{DDQ} | V _{DD} | V _{SS} | V _{SS} | V _{SS} | V _{DD} | V _{DDQ} | DQ _B | DQ _B |
| F | DQ _C | DQ _C | V _{DDQ} | V _{DD} | V _{SS} | V _{SS} | V _{SS} | V _{DD} | V _{DDQ} | DQ _B | DQ _B |
| G | DQ _C | DQ _C | V _{DDQ} | V _{DD} | V _{SS} | V _{SS} | V _{SS} | V _{DD} | V _{DDQ} | DQ _B | DQ _B |
| H | NC | NC | NC | V _{DD} | V _{SS} | V _{SS} | V _{SS} | V _{DD} | NC | NC | ZZ |
| J | DQ _D | DQ _D | V _{DDQ} | V _{DD} | V _{SS} | V _{SS} | V _{SS} | V _{DD} | V _{DDQ} | DQ _A | DQ _A |
| K | DQ _D | DQ _D | V _{DDQ} | V _{DD} | V _{SS} | V _{SS} | V _{SS} | V _{DD} | V _{DDQ} | DQ _A | DQ _A |
| L | DQ _D | DQ _D | V _{DDQ} | V _{DD} | V _{SS} | V _{SS} | V _{SS} | V _{DD} | V _{DDQ} | DQ _A | DQ _A |
| M | DQ _D | DQ _D | V _{DDQ} | V _{DD} | V _{SS} | V _{SS} | V _{SS} | V _{DD} | V _{DDQ} | DQ _A | DQ _A |
| N | DQP _D | NC | V _{DDQ} | V _{SS} | NC | A | NC | V _{SS} | V _{DDQ} | NC | DQP _A |
| P | NC | NC/72M | A | A | TDI | A1 | TDO | A | A | A | A |
| R | MODE | NC/36M | A | A | TMS | A0 | TCK | A | A | A | A |

CY7C1383F (1 M × 18)

| | 1 | 2 | 3 | 4 | 5 | 6 | 7 | 8 | 9 | 10 | 11 |
|----------|------------------|-----------------|-------------------|-------------------|-------------------|-------------------|------------------|-------------------|-------------------|-----------------|------------------|
| A | NC/288M | A | \overline{CE}_1 | \overline{BW}_B | NC | \overline{CE}_3 | \overline{BWE} | \overline{ADSC} | \overline{ADV} | A | A |
| B | NC/144M | A | CE_2 | NC | \overline{BW}_A | CLK | \overline{GW} | \overline{OE} | \overline{ADSP} | A | NC/576M |
| C | NC | NC | V _{DDQ} | V _{SS} | V _{SS} | V _{SS} | V _{SS} | V _{SS} | V _{DDQ} | NC/1G | DQP _A |
| D | NC | DQ _B | V _{DDQ} | V _{DD} | V _{SS} | V _{SS} | V _{SS} | V _{DD} | V _{DDQ} | NC | DQ _A |
| E | NC | DQ _B | V _{DDQ} | V _{DD} | V _{SS} | V _{SS} | V _{SS} | V _{DD} | V _{DDQ} | NC | DQ _A |
| F | NC | DQ _B | V _{DDQ} | V _{DD} | V _{SS} | V _{SS} | V _{SS} | V _{DD} | V _{DDQ} | NC | DQ _A |
| G | NC | DQ _B | V _{DDQ} | V _{DD} | V _{SS} | V _{SS} | V _{SS} | V _{DD} | V _{DDQ} | NC | DQ _A |
| H | V _{SS} | NC | NC | V _{DD} | V _{SS} | V _{SS} | V _{SS} | V _{DD} | NC | NC | ZZ |
| J | DQ _B | NC | V _{DDQ} | V _{DD} | V _{SS} | V _{SS} | V _{SS} | V _{DD} | V _{DDQ} | DQ _A | NC |
| K | DQ _B | NC | V _{DDQ} | V _{DD} | V _{SS} | V _{SS} | V _{SS} | V _{DD} | V _{DDQ} | DQ _A | NC |
| L | DQ _B | NC | V _{DDQ} | V _{DD} | V _{SS} | V _{SS} | V _{SS} | V _{DD} | V _{DDQ} | DQ _A | NC |
| M | DQ _B | NC | V _{DDQ} | V _{DD} | V _{SS} | V _{SS} | V _{SS} | V _{DD} | V _{DDQ} | DQ _A | NC |
| N | DQP _B | NC | V _{DDQ} | V _{SS} | NC | A | NC | V _{SS} | V _{DDQ} | NC | NC |
| P | NC | NC/72M | A | A | TDI | A1 | TDO | A | A | A | A |
| R | MODE | NC/36M | A | A | TMS | A0 | TCK | A | A | A | A |

Notes

- 3. **Errata:** The ZZ ball (H11) needs to be externally connected to ground. For more information, see "Errata" on page 32.
- 4. **Errata:** The JTAG testing should be performed with these devices in BYPASS mode as the JTAG functionality is not guaranteed. For more information, see "Errata" on page 32.

Pin Definitions

| Name | I/O | Description |
|--|-----------------------|--|
| A ₀ , A ₁ , A | Input Synchronous | Address inputs used to select one of the address locations. Sampled at the rising edge of the CLK if ADSP or ADSC is active LOW, and \overline{CE}_1 , CE ₂ , and \overline{CE}_3 are sampled active. A _[1:0] feed the 2-bit counter. |
| \overline{BW}_A , \overline{BW}_B , \overline{BW}_C , \overline{BW}_D | Input Synchronous | Byte write select inputs, active LOW. Qualified with \overline{BWE} to conduct byte writes to the SRAM. Sampled on the rising edge of CLK. |
| \overline{GW} | Input Synchronous | Global write enable input, active LOW. When asserted LOW on the rising edge of CLK, a global write is conducted (all bytes are written, regardless of the values on $\overline{BW}_{[A:D]}$ and \overline{BWE}). |
| CLK | Input Clock | Clock input. Used to capture all synchronous inputs to the device. Also used to increment the burst counter when ADV is asserted LOW, during a burst operation. |
| \overline{CE}_1 | Input Synchronous | Chip enable 1 input, active LOW. Sampled on the rising edge of CLK. Used in conjunction with CE ₂ and CE ₃ to select or deselect the device. ADSP is ignored if \overline{CE}_1 is HIGH. \overline{CE}_1 is sampled only when a new external address is loaded. |
| CE ₂ | Input Synchronous | Chip enable 2 input, active HIGH. Sampled on the rising edge of CLK. Used in conjunction with \overline{CE}_1 and \overline{CE}_3 to select or deselect the device. CE ₂ is sampled only when a new external address is loaded. |
| \overline{CE}_3 | Input Synchronous | Chip enable 3 input, active LOW. Sampled on the rising edge of CLK. Used in conjunction with \overline{CE}_1 and CE ₂ to select or deselect the device. \overline{CE}_3 is sampled only when a new external address is loaded. |
| \overline{OE} | Input Asynchronous | Output enable, asynchronous input, active LOW. Controls the direction of the I/O pins. When LOW, the I/O pins behave as outputs. When deasserted HIGH, I/O pins are tristated, and act as input data pins. \overline{OE} is masked during the first clock of a read cycle when emerging from a deselected state. |
| ADV | Input Synchronous | Advance input signal. Sampled on the rising edge of CLK. When asserted, it automatically increments the address in a burst cycle. |
| ADSP | Input Synchronous | Address strobe from processor, sampled on the rising edge of CLK, active LOW. When asserted LOW, addresses presented to the device are captured in the address registers. A _[1:0] are also loaded into the burst counter. When ADSP and ADSC are both asserted, only ADSP is recognized. ADSP is ignored when \overline{CE}_1 is deasserted HIGH. |
| ADSC | Input Synchronous | Address strobe from controller, sampled on the rising edge of CLK, active LOW. When asserted LOW, addresses presented to the device are captured in the address registers. A _[1:0] are also loaded into the burst counter. When ADSP and ADSC are both asserted, only ADSP is recognized. |
| \overline{BWE} | Input Synchronous | Byte write enable input, active LOW. Sampled on the rising edge of CLK. This signal must be asserted LOW to conduct a byte write. |
| ZZ ^[5] | Input Asynchronous | ZZ sleep input. This active HIGH input places the device in a non time critical sleep condition with data integrity preserved. For normal operation, this pin has to be LOW or left floating. ZZ pin has an internal pull down. |
| DQ _s | I/O Synchronous | Bidirectional data I/O lines. As inputs, they feed into an on-chip data register that is triggered by the rising edge of CLK. As outputs, they deliver the data contained in the memory location specified by the addresses presented during the previous clock rise of the read cycle. The direction of the pins is controlled by \overline{OE} . When \overline{OE} is asserted LOW, the pins behave as outputs. When HIGH, DQ _s and DQP _x are placed in a tristate condition. The outputs are automatically tristated during the data portion of a write sequence, during the first clock when emerging from a deselected state, and when the device is deselected, regardless of the state of \overline{OE} . |
| DQP _x | I/O Synchronous | Bidirectional data parity I/O lines. Functionally, these signals are identical to DQ _s . During write sequences, DQP _x is controlled by \overline{BW}_x correspondingly. |

Note

5. **Errata:** The ZZ pin needs to be externally connected to ground. For more information, see "Errata" on page 32.

Pin Definitions *(continued)*

| Name | I/O | Description |
|--------------------|--------------------------------|--|
| MODE | Input Static | Selects burst order. When tied to GND selects linear burst sequence. When tied to V_{DD} or left floating selects interleaved burst sequence. This is a strap pin and must remain static during device operation. Mode pin has an internal pull-up. |
| V_{DD} | Power Supply | Power supply inputs to the core of the device. |
| V_{DDQ} | I/O Power Supply | Power supply for the I/O circuitry. |
| V_{SS} | Ground | Ground for the core of the device. |
| V_{SSQ} | I/O Ground | Ground for the I/O circuitry. |
| TDO ^[6] | JTAG Serial Output Synchronous | Serial data-out to the JTAG circuit. Delivers data on the negative edge of TCK. If the JTAG feature is not being used, this pin can be left unconnected. This pin is not available on TQFP packages. |
| TDI ^[6] | JTAG Serial Input Synchronous | Serial data-in to the JTAG circuit. Sampled on the rising edge of TCK. If the JTAG feature is not being used, this pin can be left floating or connected to V_{DD} through a pull-up resistor. This pin is not available on TQFP packages. |
| TMS ^[6] | JTAG Serial Input Synchronous | Serial data-in to the JTAG circuit. Sampled on the rising edge of TCK. If the JTAG feature is not being used, this pin can be disconnected or connected to V_{DD} . This pin is not available on TQFP packages. |
| TCK ^[6] | JTAG Clock | Clock input to the JTAG circuitry. If the JTAG feature is not being used, this pin must be connected to V_{SS} . This pin is not available on TQFP packages. |
| NC | – | No connects. Not internally connected to the die. 36M, 72M, 144M, 288M, 576M, and 1G are address expansion pins and are not internally connected to the die. |
| V_{SS}/DNU | Ground/DNU | This pin can be connected to ground or can be left floating. |

Note

6. **Errata:** The JTAG testing should be performed with these devices in BYPASS mode as the JTAG functionality is not guaranteed. For more information, see "Errata" on page 32.

Functional Overview

All synchronous inputs pass through input registers controlled by the rising edge of the clock. Maximum access delay from the clock rise (t_{CDV}) is 6.5 ns (133 MHz device).

CY7C1381D/CY7C1383D/CY7C1383F supports secondary cache in systems using a linear or interleaved burst sequence. The interleaved burst order supports Pentium and i486 processors. The linear burst sequence is suited for processors that use a linear burst sequence. The burst order is user selectable, and is determined by sampling the MODE input. Accesses can be initiated with the processor address strobe (ADSP) or the controller address strobe (ADSC). Address advancement through the burst sequence is controlled by the ADV input. A two-bit on-chip wraparound burst counter captures the first address in a burst sequence and automatically increments the address for the rest of the burst access.

Byte write operations are qualified with the byte write enable (\overline{BWE}) and byte write select ($\overline{BW_X}$) inputs. A global write enable (\overline{GW}) overrides all byte write inputs and writes data to all four bytes. All writes are simplified with on-chip synchronous self-timed write circuitry.

Three synchronous chip selects ($\overline{CE_1}$, CE_2 , $\overline{CE_3}$) and an asynchronous output enable (\overline{OE}) provide easy bank selection and output tristate control. ADSP is ignored if $\overline{CE_1}$ is HIGH.

Single Read Accesses

A single read access is initiated when the following conditions are satisfied at clock rise: (1) $\overline{CE_1}$, CE_2 , and $\overline{CE_3}$ are all asserted active, and (2) ADSP or ADSC is asserted LOW (if the access is initiated by ADSC, the write inputs must be deasserted during this first cycle). The address presented to the address inputs is latched into the address register and the burst counter and/or control logic, and later presented to the memory core. If the OE input is asserted LOW, the requested data is available at the data outputs with a maximum to t_{CDV} after clock rise. ADSP is ignored if $\overline{CE_1}$ is HIGH.

Single Write Accesses Initiated by ADSP

This access is initiated when the following conditions are satisfied at clock rise: (1) $\overline{CE_1}$, CE_2 , $\overline{CE_3}$ are all asserted active, and (2) ADSP is asserted LOW. The addresses presented are loaded into the address register and the burst inputs (\overline{GW} , \overline{BWE} , and $\overline{BW_X}$) are ignored during this first clock cycle. If the write inputs are asserted active (see [Truth Table for Read/Write on](#)

[page 11](#) for appropriate states that indicate a write) on the next clock rise, the appropriate data is latched and written into the device. Byte writes are allowed. All I/O are tristated during a byte write. As this is a common I/O device, the asynchronous \overline{OE} input signal must be deasserted and the I/O must be tristated prior to the presentation of data to DQs. As a safety precaution, the data lines are tristated when a write cycle is detected, regardless of the state of \overline{OE} .

Single Write Accesses Initiated by ADSC

This write access is initiated when the following conditions are satisfied at clock rise: (1) $\overline{CE_1}$, CE_2 , and $\overline{CE_3}$ are all asserted active, (2) ADSC is asserted LOW, (3) ADSP is deasserted HIGH, and (4) the write input signals (\overline{GW} , \overline{BWE} , and $\overline{BW_X}$) indicate a write access. ADSC is ignored if ADSP is active LOW.

The addresses presented are loaded into the address register and the burst counter, the control logic, or both, and delivered to the memory core. The information presented to $DQ_{[A:D]}$ is written into the specified address location. Byte writes are allowed. All I/O are tristated when a write is detected, even a byte write. Because this is a common I/O device, the asynchronous \overline{OE} input signal must be deasserted and the I/O must be tristated prior to the presentation of data to DQs. As a safety precaution, the data lines are tristated when a write cycle is detected, regardless of the state of \overline{OE} .

Burst Sequences

CY7C1381D/CY7C1383D/CY7C1383F provides an on-chip two-bit wraparound burst counter inside the SRAM. The burst counter is fed by $A_{[1:0]}$, and can follow either a linear or interleaved burst order. The burst order is determined by the state of the MODE input. A LOW on MODE selects a linear burst sequence. A HIGH on MODE selects an interleaved burst order. Leaving MODE unconnected causes the device to default to a interleaved burst sequence.

Sleep Mode

The ZZ input pin is an asynchronous input. Asserting ZZ places the SRAM in a power conservation sleep mode. Two clock cycles are required to enter into or exit from this sleep mode. While in this mode, data integrity is guaranteed. Accesses pending when entering the sleep mode are not considered valid nor is the completion of the operation guaranteed. The device must be deselected prior to entering the sleep mode. $\overline{CE_1}$, CE_2 , $\overline{CE_3}$, ADSP, and ADSC must remain inactive for the duration of t_{ZZREC} after the ZZ input returns LOW.

Interleaved Burst Address Table

(MODE = Floating or V_{DD})

| First Address A1:A0 | Second Address A1:A0 | Third Address A1:A0 | Fourth Address A1:A0 |
|---------------------|----------------------|---------------------|----------------------|
| 00 | 01 | 10 | 11 |
| 01 | 00 | 11 | 10 |
| 10 | 11 | 00 | 01 |
| 11 | 10 | 01 | 00 |

Linear Burst Address Table

(MODE = GND)

| First Address A1:A0 | Second Address A1:A0 | Third Address A1:A0 | Fourth Address A1:A0 |
|---------------------|----------------------|---------------------|----------------------|
| 00 | 01 | 10 | 11 |
| 01 | 10 | 11 | 00 |
| 10 | 11 | 00 | 01 |
| 11 | 00 | 01 | 10 |

ZZ Mode Electrical Characteristics

| Parameter | Description | Test Conditions | Min | Max | Unit |
|-------------|-----------------------------------|---------------------------|------------|------------|------|
| I_{DDZZ} | Sleep mode standby current | $ZZ \geq V_{DD} - 0.2 V$ | – | 80 | mA |
| t_{ZZS} | Device operation to ZZ | $ZZ \geq V_{DD} - 0.2 V$ | – | $2t_{CYC}$ | ns |
| t_{ZZREC} | ZZ recovery time | $ZZ \leq 0.2 V$ | $2t_{CYC}$ | – | ns |
| t_{ZZI} | ZZ active to sleep current | This parameter is sampled | – | $2t_{CYC}$ | ns |
| t_{RZZI} | ZZ inactive to exit sleep current | This parameter is sampled | 0 | – | ns |

Truth Table

The truth table for CY7C1381D/CY7C1383D/CY7C1383F follows. [7, 8, 9, 10, 11]

| Cycle Description | Address Used | \overline{CE}_1 | \overline{CE}_2 | \overline{CE}_3 | ZZ | \overline{ADSP} | \overline{ADSC} | \overline{ADV} | \overline{WRITE} | \overline{OE} | CLK | DQ |
|------------------------------|--------------|-------------------|-------------------|-------------------|----|-------------------|-------------------|------------------|--------------------|-----------------|-----|-----------|
| Deselected Cycle, Power Down | None | H | X | X | L | X | L | X | X | X | L-H | Tri-State |
| Deselected Cycle, Power Down | None | L | L | X | L | L | X | X | X | X | L-H | Tri-State |
| Deselected Cycle, Power Down | None | L | X | H | L | L | X | X | X | X | L-H | Tri-State |
| Deselected Cycle, Power Down | None | L | L | X | L | H | L | X | X | X | L-H | Tri-State |
| Deselected Cycle, Power Down | None | X | X | X | L | H | L | X | X | X | L-H | Tri-State |
| Sleep Mode, Power Down | None | X | X | X | H | X | X | X | X | X | X | Tri-State |
| Read Cycle, Begin Burst | External | L | H | L | L | L | X | X | X | L | L-H | Q |
| Read Cycle, Begin Burst | External | L | H | L | L | L | X | X | X | H | L-H | Tri-State |
| Write Cycle, Begin Burst | External | L | H | L | L | H | L | X | L | X | L-H | D |
| Read Cycle, Begin Burst | External | L | H | L | L | H | L | X | H | L | L-H | Q |
| Read Cycle, Begin Burst | External | L | H | L | L | H | L | X | H | H | L-H | Tri-State |
| Read Cycle, Continue Burst | Next | X | X | X | L | H | H | L | H | L | L-H | Q |
| Read Cycle, Continue Burst | Next | X | X | X | L | H | H | L | H | H | L-H | Tri-State |
| Read Cycle, Continue Burst | Next | H | X | X | L | X | H | L | H | L | L-H | Q |
| Read Cycle, Continue Burst | Next | H | X | X | L | X | H | L | H | H | L-H | Tri-State |
| Write Cycle, Continue Burst | Next | X | X | X | L | H | H | L | L | X | L-H | D |
| Write Cycle, Continue Burst | Next | H | X | X | L | X | H | L | L | X | L-H | D |
| Read Cycle, Suspend Burst | Current | X | X | X | L | H | H | H | H | L | L-H | Q |
| Read Cycle, Suspend Burst | Current | X | X | X | L | H | H | H | H | H | L-H | Tri-State |
| Read Cycle, Suspend Burst | Current | H | X | X | L | X | H | H | H | L | L-H | Q |
| Read Cycle, Suspend Burst | Current | H | X | X | L | X | H | H | H | H | L-H | Tri-State |
| Write Cycle, Suspend Burst | Current | X | X | X | L | H | H | H | L | X | L-H | D |
| Write Cycle, Suspend Burst | Current | H | X | X | L | X | H | H | L | X | L-H | D |

Notes

7. X = Don't Care, H = Logic HIGH, L = Logic LOW.
8. \overline{WRITE} = L when any one or more byte write enable signals, and \overline{BWE} = L or \overline{GW} = L. \overline{WRITE} = H when all byte write enable signals, \overline{BWE} , \overline{GW} = H.
9. The DQ pins are controlled by the current cycle and the \overline{OE} signal. \overline{OE} is asynchronous and is not sampled with the clock.
10. The SRAM always initiates a read cycle when \overline{ADSP} is asserted, regardless of the state of \overline{GW} , \overline{BWE} , or \overline{BW}_x . Writes may occur only on subsequent clocks after the \overline{ADSP} or with the assertion of \overline{ADSC} . As a result, \overline{OE} must be driven HIGH prior to the start of the write cycle to allow the outputs to tristate. \overline{OE} is a don't care for the remainder of the write cycle.
11. \overline{OE} is asynchronous and is not sampled with the clock rise. It is masked internally during write cycles. During a read cycle all data bits are tristate when \overline{OE} is inactive or when the device is deselected, and all data bits behave as output when \overline{OE} is active (LOW).

Truth Table for Read/Write

The truth table for CY7C1381D read/write follows. [12, 13]

| Function (CY7C1381D) | \overline{GW} | \overline{BWE} | \overline{BW}_D | \overline{BW}_C | \overline{BW}_B | \overline{BW}_A |
|---|-----------------|------------------|-------------------|-------------------|-------------------|-------------------|
| Read | H | H | X | X | X | X |
| Read | H | L | H | H | H | H |
| Write Byte A (DQ _A , DQP _A) | H | L | H | H | H | L |
| Write Byte B(DQ _B , DQP _B) | H | L | H | H | L | H |
| Write Bytes A, B (DQ _A , DQ _B , DQP _A , DQP _B) | H | L | H | H | L | L |
| Write Byte C (DQ _C , DQP _C) | H | L | H | L | H | H |
| Write Bytes C, A (DQ _C , DQ _A , DQP _C , DQP _A) | H | L | H | L | H | L |
| Write Bytes C, B (DQ _C , DQ _B , DQP _C , DQP _B) | H | L | H | L | L | H |
| Write Bytes C, B, A (DQ _C , DQ _B , DQ _A , DQP _C , DQP _B , DQP _A) | H | L | H | L | L | L |
| Write Byte D (DQ _D , DQP _D) | H | L | L | H | H | H |
| Write Bytes D, A (DQ _D , DQ _A , DQP _D , DQP _A) | H | L | L | H | H | L |
| Write Bytes D, B (DQ _D , DQ _B , DQP _D , DQP _B) | H | L | L | H | L | H |
| Write Bytes D, B, A (DQ _D , DQ _B , DQ _A , DQP _D , DQP _B , DQP _A) | H | L | L | H | L | L |
| Write Bytes D, B (DQ _D , DQ _B , DQP _D , DQP _B) | H | L | L | L | H | H |
| Write Bytes D, B, A (DQ _D , DQ _C , DQ _A , DQP _D , DQP _C , DQP _A) | H | L | L | L | H | L |

Truth Table for Read/Write

The truth table for CY7C1383D/CY7C1383F read/write follows. [12, 13]

| Function (CY7C1383D/CY7C1383F) | \overline{GW} | \overline{BWE} | \overline{BW}_B | \overline{BW}_A |
|---|-----------------|------------------|-------------------|-------------------|
| Write Bytes D, C, A (DQ _D , DQ _B , DQ _A , DQP _D , DQP _B , DQP _A) | H | L | L | L |
| Write All Bytes | H | L | L | L |
| Write All Bytes | L | X | X | X |
| Read | H | H | X | X |
| Read | H | L | H | H |
| Write Byte A – (DQ _A and DQP _A) | H | L | H | L |
| Write Byte B – (DQ _B and DQP _B) | H | L | L | H |
| Write All Bytes | H | L | L | L |
| Write All Bytes | L | X | X | X |

Notes

12. X=Don't Care, H = Logic HIGH, L = Logic LOW.

13. The table only lists a partial listing of the byte write combinations. Any combination of \overline{BW}_x is valid. Appropriate write is done based on which byte write is active.

IEEE 1149.1 Serial Boundary Scan (JTAG) ^[14]

The CY7C1381D/CY7C1383F incorporates a serial boundary scan test access port (TAP). This part is fully compliant with 1149.1. The TAP operates using JEDEC-standard 3.3 V or 2.5 V I/O logic levels.

CY7C1381D/CY7C1383F contains a TAP controller, instruction register, boundary scan register, bypass register, and ID register.

Disabling the JTAG Feature

It is possible to operate the SRAM without using the JTAG feature. To disable the TAP controller, TCK must be tied LOW (V_{SS}) to prevent clocking of the device. TDI and TMS are internally pulled up and may be unconnected. They may alternately be connected to V_{DD} through a pull-up resistor. TDO may be left unconnected. At power up, the device comes up in a reset state, which does not interfere with the operation of the device.

Test Access Port (TAP)

Test Clock (TCK)

The test clock is used only with the TAP controller. All inputs are captured on the rising edge of TCK. All outputs are driven from the falling edge of TCK.

Test Mode Select (TMS)

The TMS input is used to give commands to the TAP controller and is sampled on the rising edge of TCK. This pin may be left unconnected if the TAP is not used. The ball is pulled up internally, resulting in a logic HIGH level.

Test Data-In (TDI)

The TDI ball is used to serially input information into the registers and can be connected to the input of any of the registers. The register between TDI and TDO is chosen by the instruction that is loaded into the TAP instruction register. For information on loading the instruction register, see the [TAP Controller State Diagram on page 14](#). TDI is internally pulled up and can be unconnected if the TAP is unused in an application. TDI is connected to the most significant bit (MSB) of any register.

Test Data-Out (TDO)

The TDO output ball is used to serially clock data-out from the registers. The output is active depending upon the current state of the TAP state machine (see [Instruction Codes on page 18](#)). The output changes on the falling edge of TCK. TDO is connected to the least significant bit (LSB) of any register.

Performing a TAP Reset

A reset is performed by forcing TMS HIGH (V_{DD}) for five rising edges of TCK. This reset does not affect the operation of the SRAM and may be performed while the SRAM is operating. At

power up, the TAP is reset internally to ensure that TDO comes up in a high Z state.

TAP Registers

Registers are connected between the TDI and TDO balls and allow data to be scanned in and out of the SRAM test circuitry. Only one register can be selected at a time through the instruction registers. Data is serially loaded into the TDI ball on the rising edge of TCK. Data is output on the TDO ball on the falling edge of TCK.

Instruction Register

Three-bit instructions can be serially loaded into the instruction register. This register is loaded when it is placed between the TDI and TDO balls as shown in the [TAP Controller Block Diagram on page 15](#). Upon power up, the instruction register is loaded with the IDCODE instruction. It is also loaded with the IDCODE instruction if the controller is placed in a reset state as described in the previous section.

When the TAP controller is in the Capture-IR state, the two least significant bits are loaded with a binary '01' pattern to allow for fault isolation of the board level serial test path.

Bypass Register

To save time when serially shifting data through registers, it is sometimes advantageous to skip certain chips. The bypass register is a single-bit register that can be placed between the TDI and TDO balls. This allows data to be shifted through the SRAM with minimal delay. The bypass register is set LOW (V_{SS}) when the BYPASS instruction is executed.

Boundary Scan Register

The boundary scan register is connected to all the input and bidirectional balls on the SRAM.

The boundary scan register is loaded with the contents of the RAM input and output ring when the TAP controller is in the Capture-DR state and is then placed between the TDI and TDO balls when the controller is moved to the Shift-DR state. The EXTTEST, SAMPLE/PRELOAD, and SAMPLE Z instructions can be used to capture the contents of the input and output ring.

The [Boundary Scan Order on page 19](#) show the order in which the bits are connected. Each bit corresponds to one of the bumps on the SRAM package. The MSB of the register is connected to TDI, and the LSB is connected to TDO.

Identification (ID) Register

The ID register is loaded with a vendor-specific 32-bit code during the Capture-DR state when the IDCODE command is loaded in the instruction register. The IDCODE is hardwired into the SRAM and can be shifted out when the TAP controller is in the Shift-DR state. The ID register has a vendor code and other information described in [Identification Register Definitions on page 18](#).

Note

14. Errata: The JTAG testing should be performed with these devices in BYPASS mode as the JTAG functionality is not guaranteed. For more information, see "Errata" on page 32.

TAP Instruction Set

Overview

Eight different instructions are possible with the three bit instruction register. All combinations are listed in [Instruction Codes on page 18](#). Three of these instructions are listed as RESERVED and must not be used. The other five instructions are described in detail below.

Instructions are loaded into the TAP controller during the Shift-IR state, when the instruction register is placed between TDI and TDO. During this state, instructions are shifted through the instruction register through the TDI and TDO balls. To execute the instruction when it is shifted in, the TAP controller needs to be moved into the Update-IR state.

EXTEST

The EXTEST instruction enables the preloaded data to be driven out through the system output pins. This instruction also selects the boundary scan register to be connected for serial access between the TDI and TDO in the Shift-DR controller state.

IDCODE

The IDCODE instruction causes a vendor-specific 32-bit code to be loaded into the instruction register. It also places the instruction register between the TDI and TDO balls and allows the IDCODE to be shifted out of the device when the TAP controller enters the Shift-DR state.

The IDCODE instruction is loaded into the instruction register upon power up or whenever the TAP controller is given a test logic reset state.

SAMPLE Z

The SAMPLE Z instruction causes the boundary scan register to be connected between the TDI and TDO balls when the TAP controller is in a Shift-DR state. The SAMPLE Z command places all SRAM outputs into a high Z state.

SAMPLE/PRELOAD

SAMPLE/PRELOAD is a 1149.1 mandatory instruction. When the SAMPLE/PRELOAD instructions are loaded into the instruction register and the TAP controller is in the Capture-DR state, a snapshot of data on the inputs and output pins is captured in the boundary scan register.

The user must be aware that the TAP controller clock can only operate at a frequency up to 20 MHz, while the SRAM clock operates more than an order of magnitude faster. Because there is a large difference in the clock frequencies, it is possible that during the Capture-DR state, an input or output undergoes a transition. The TAP may then try to capture a signal while in transition (metastable state). This does not harm the device, but

there is no guarantee as to the value that is captured. Repeatable results may not be possible.

To guarantee that the boundary scan register captures the correct value of a signal, the SRAM signal must be stabilized long enough to meet the TAP controller's capture setup plus hold times (t_{CS} and t_{CH}). The SRAM clock input might not be captured correctly if there is no way in a design to stop (or slow) the clock during a SAMPLE/PRELOAD instruction. If this is an issue, it is still possible to capture all other signals and simply ignore the value of the CK and \overline{CK} captured in the boundary scan register.

After the data is captured, it is possible to shift out the data by putting the TAP into the Shift-DR state. This places the boundary scan register between the TDI and TDO pins.

PRELOAD allows an initial data pattern to be placed at the latched parallel outputs of the boundary scan register cells prior to the selection of another boundary scan test operation.

The shifting of data for the SAMPLE and PRELOAD phases can occur concurrently when required; that is, while data captured is shifted out, the preloaded data is shifted in.

BYPASS

When the BYPASS instruction is loaded in the instruction register and the TAP is placed in a Shift-DR state, the bypass register is placed between the TDI and TDO balls. The advantage of the BYPASS instruction is that it shortens the boundary scan path when multiple devices are connected together on a board.

EXTEST Output Bus Tri-State

IEEE standard 1149.1 mandates that the TAP controller be able to put the output bus into a tristate mode.

The boundary scan register has a special bit located at bit #89 (for 165-ball FBGA package). When this scan cell, called the "extest output bus tristate," is latched into the preload register during the Update-DR state in the TAP controller, it directly controls the state of the output (Q-bus) pins, when the EXTEST is entered as the current instruction. When HIGH, it enables the output buffers to drive the output bus. When LOW, this bit places the output bus into a high Z condition.

This bit can be set by entering the SAMPLE/PRELOAD or EXTEST command, and then shifting the desired bit into that cell, during the Shift-DR state. During Update-DR, the value loaded into that shift-register cell latches into the preload register. When the EXTEST instruction is entered, this bit directly controls the output Q-bus pins. Note that this bit is preset HIGH to enable the output when the device is powered up, and also when the TAP controller is in the Test-Logic-Reset state.

Reserved

These instructions are not implemented but are reserved for future use. Do not use these instructions.

TAP Controller State Diagram

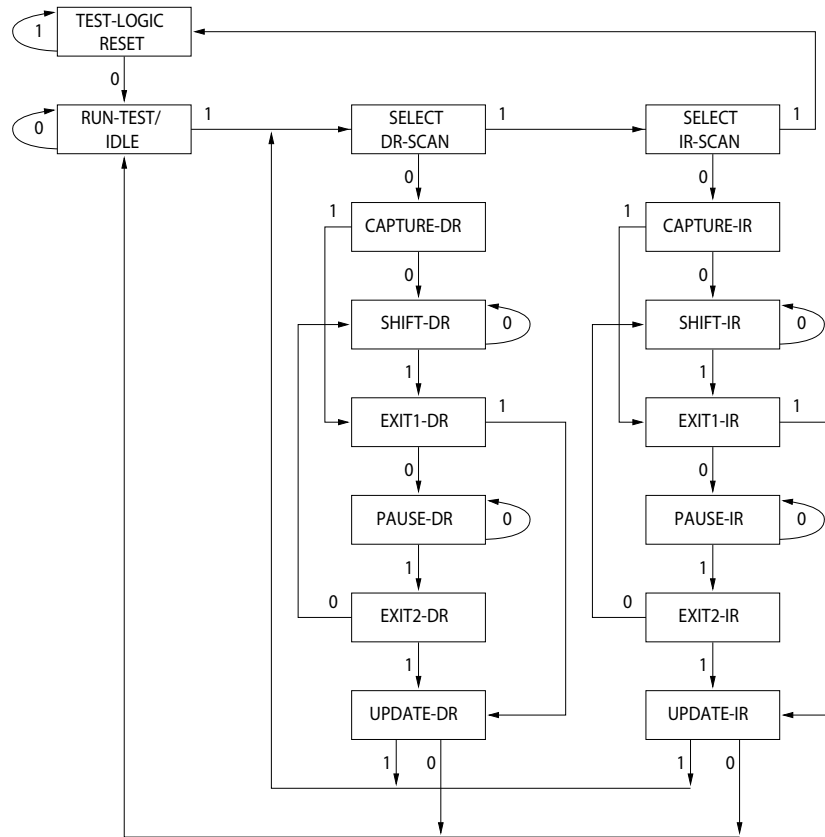

The 0 or 1 next to each state represents the value of TMS at the rising edge of TCK.

TAP Controller Block Diagram

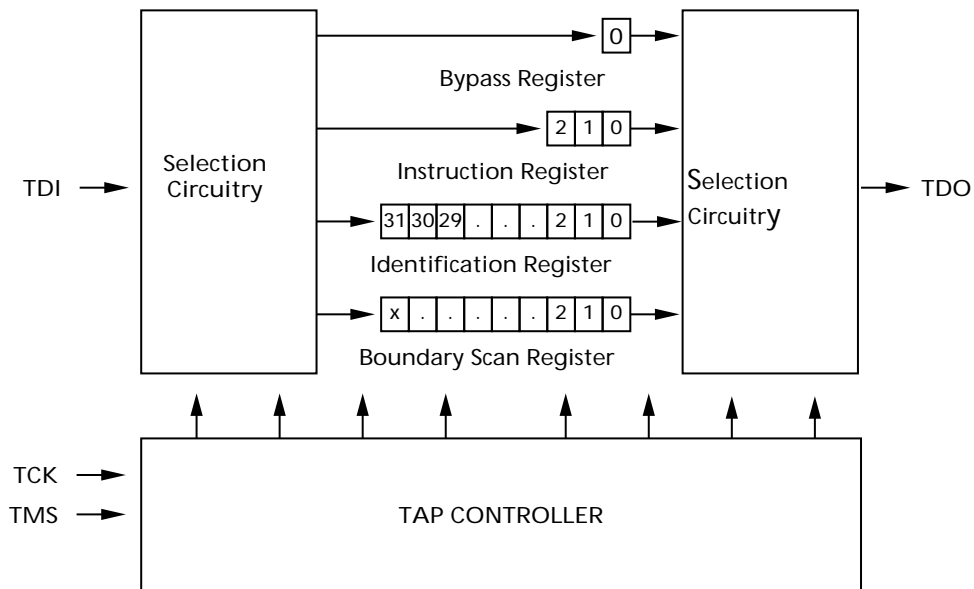

TAP Timing

Figure 3. TAP Timing

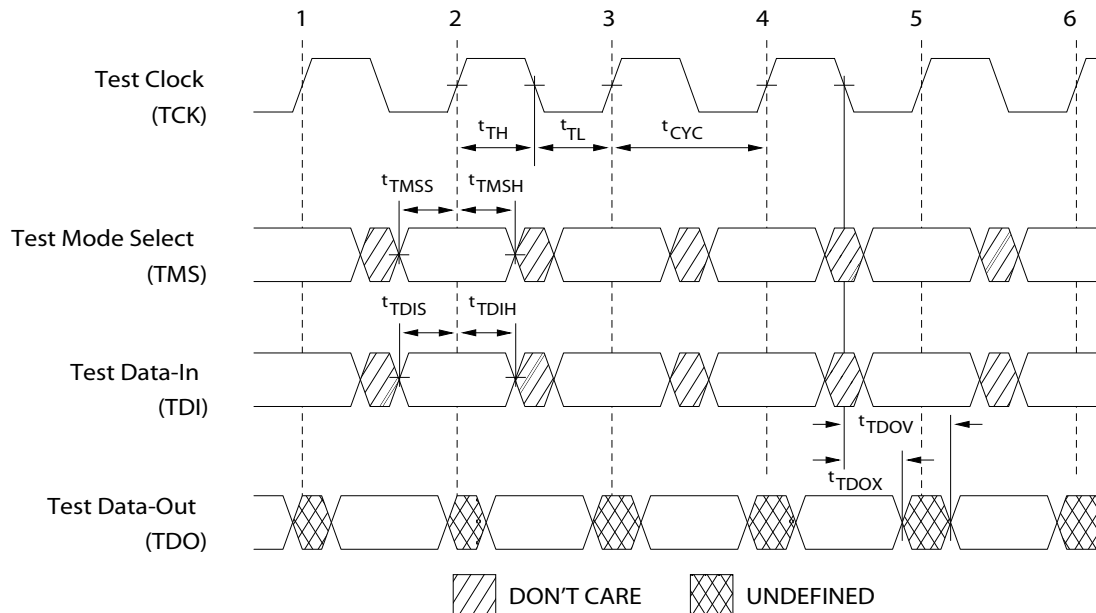

TAP AC Switching Characteristics

Over the Operating Range

| Parameter ^[15, 16] | Description | Min | Max | Unit |
|-------------------------------|-------------------------------|-----|-----|------|
| Clock | | | | |
| t_{TCYC} | TCK Clock Cycle Time | 50 | – | ns |
| f_{TF} | TCK Clock Frequency | – | 20 | MHz |
| t_{TH} | TCK Clock HIGH Time | 20 | – | ns |
| t_{TL} | TCK Clock LOW Time | 20 | – | ns |
| Output Times | | | | |
| t_{TDOV} | TCK Clock LOW to TDO Valid | – | 10 | ns |
| t_{TDOX} | TCK Clock LOW to TDO Invalid | 0 | – | ns |
| Setup Times | | | | |
| t_{TMSS} | TMS Setup to TCK Clock Rise | 5 | – | ns |
| t_{TDIS} | TDI Setup to TCK Clock Rise | 5 | – | ns |
| t_{CS} | Capture Setup to TCK Rise | 5 | – | ns |
| Hold Times | | | | |
| t_{TMSH} | TMS Hold after TCK Clock Rise | 5 | – | ns |
| t_{TDIH} | TDI Hold after Clock Rise | 5 | – | ns |
| t_{CH} | Capture Hold after Clock Rise | 5 | – | ns |

Notes

15. t_{CS} and t_{CH} refer to the setup and hold time requirements of latching data from the boundary scan register.

16. Test conditions are specified using the load in TAP AC test conditions. $t_R/t_F = 1$ ns.

3.3 V TAP AC Test Conditions

Input pulse levels V_{SS} to 3.3 V
 Input rise and fall times 1 ns
 Input timing reference levels 1.5 V
 Output reference levels 1.5 V
 Test load termination supply voltage 1.5 V

2.5 V TAP AC Test Conditions

Input pulse levels V_{SS} to 2.5 V
 Input rise and fall time 1 ns
 Input timing reference levels 1.25 V
 Output reference levels 1.25 V
 Test load termination supply voltage 1.25 V

3.3 V TAP AC Output Load Equivalent

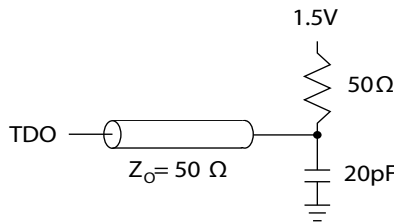

2.5 V TAP AC Output Load Equivalent

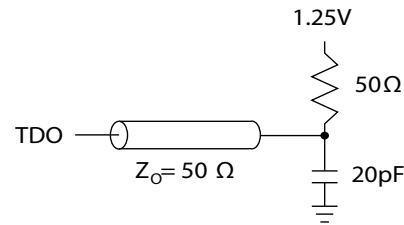

TAP DC Electrical Characteristics and Operating Conditions

(0 °C < T_A < +70 °C; V_{DD} = 3.3 V ± 0.165 V unless otherwise noted)

| Parameter ^[17] | Description | Test Conditions | | Min | Max | Unit |
|---------------------------|---------------------|--|--------------------------|------|-----------------------|------|
| V _{OH1} | Output HIGH Voltage | I _{OH} = -4.0 mA | V _{DDQ} = 3.3 V | 2.4 | - | V |
| | | I _{OH} = -1.0 mA | V _{DDQ} = 2.5 V | 2.0 | - | V |
| V _{OH2} | Output HIGH Voltage | I _{OH} = -100 µA | V _{DDQ} = 3.3 V | 2.9 | - | V |
| | | | V _{DDQ} = 2.5 V | 2.1 | - | V |
| V _{OL1} | Output LOW Voltage | I _{OL} = 8.0 mA | V _{DDQ} = 3.3 V | - | 0.4 | V |
| | | I _{OL} = 8.0 mA | V _{DDQ} = 2.5 V | - | 0.4 | V |
| V _{OL2} | Output LOW Voltage | I _{OL} = 100 µA | V _{DDQ} = 3.3 V | - | 0.2 | V |
| | | | V _{DDQ} = 2.5 V | - | 0.2 | V |
| V _{IH} | Input HIGH Voltage | | V _{DDQ} = 3.3 V | 2.0 | V _{DD} + 0.3 | V |
| | | | V _{DDQ} = 2.5 V | 1.7 | V _{DD} + 0.3 | V |
| V _{IL} | Input LOW Voltage | | V _{DDQ} = 3.3 V | -0.3 | 0.8 | V |
| | | | V _{DDQ} = 2.5 V | -0.3 | 0.7 | V |
| I _X | Input Load Current | GND ≤ V _{IN} ≤ V _{DDQ} | | -5 | 5 | µA |

Note
 17. All voltages referenced to V_{SS} (GND).

Identification Register Definitions

| Instruction Field | CY7C1381D (512 K × 36) | CY7C1383F (1 M × 18) | Description |
|--------------------------------------|---------------------------|-------------------------|--|
| Revision Number (31:29) | 000 | 000 | Describes the version number. |
| Device Depth (28:24) ^[18] | 01011 | 01011 | Reserved for internal use. |
| Device Width (23:18) 165-ball FBGA | 000001 | 000001 | Defines the memory type and architecture. |
| Cypress Device ID (17:12) | 100101 | 010101 | Defines the width and density. |
| Cypress JEDEC ID Code (11:1) | 00000110100 | 00000110100 | Allows unique identification of SRAM vendor. |
| ID Register Presence Indicator (0) | 1 | 1 | Indicates the presence of an ID register. |

Scan Register Sizes

| Register Name | Bit Size (× 36) | Bit Size (× 18) |
|---|-----------------|-----------------|
| Instruction Bypass | 3 | 3 |
| Bypass | 1 | 1 |
| ID | 32 | 32 |
| Boundary Scan Order (165-ball FBGA package) | 89 | 89 |

Instruction Codes

| Instruction | Code | Description |
|----------------|------|---|
| EXTTEST | 000 | Captures Input/Output ring contents. Places the boundary scan register between TDI and TDO. Forces all SRAM outputs to high Z state. |
| IDCODE | 001 | Loads the ID register with the vendor ID code and places the register between TDI and TDO. This operation does not affect SRAM operations. |
| SAMPLE Z | 010 | Captures Input/Output ring contents. Places the boundary scan register between TDI and TDO. Forces all SRAM output drivers to a high Z state. |
| RESERVED | 011 | Do Not Use. This instruction is reserved for future use. |
| SAMPLE/PRELOAD | 100 | Captures Input/Output ring contents. Places the boundary scan register between TDI and TDO. Does not affect SRAM operation. |
| RESERVED | 101 | Do Not Use. This instruction is reserved for future use. |
| RESERVED | 110 | Do Not Use. This instruction is reserved for future use. |
| BYPASS | 111 | Places the bypass register between TDI and TDO. This operation does not affect SRAM operations. |

Note

18. Bit #24 is "1" in the register definitions for both 2.5 V and 3.3 V versions of this device.

Boundary Scan Order

165-ball FBGA [19, 20]

| Bit # | Ball ID |
|-------|---------|
| 1 | N6 |
| 2 | N7 |
| 3 | N10 |
| 4 | P11 |
| 5 | P8 |
| 6 | R8 |
| 7 | R9 |
| 8 | P9 |
| 9 | P10 |
| 10 | R10 |
| 11 | R11 |
| 12 | H11 |
| 13 | N11 |
| 14 | M11 |
| 15 | L11 |
| 16 | K11 |
| 17 | J11 |
| 18 | M10 |
| 19 | L10 |
| 20 | K10 |
| 21 | J10 |
| 22 | H9 |
| 23 | H10 |
| 24 | G11 |
| 25 | F11 |
| 26 | E11 |
| 27 | D11 |
| 28 | G10 |
| 29 | F10 |
| 30 | E10 |

| Bit # | Ball ID |
|-------|---------|
| 31 | D10 |
| 32 | C11 |
| 33 | A11 |
| 34 | B11 |
| 35 | A10 |
| 36 | B10 |
| 37 | A9 |
| 38 | B9 |
| 39 | C10 |
| 40 | A8 |
| 41 | B8 |
| 42 | A7 |
| 43 | B7 |
| 44 | B6 |
| 45 | A6 |
| 46 | B5 |
| 47 | A5 |
| 48 | A4 |
| 49 | B4 |
| 50 | B3 |
| 51 | A3 |
| 52 | A2 |
| 53 | B2 |
| 54 | C2 |
| 55 | B1 |
| 56 | A1 |
| 57 | C1 |
| 58 | D1 |
| 59 | E1 |
| 60 | F1 |

| Bit # | Ball ID |
|-------|----------|
| 61 | G1 |
| 62 | D2 |
| 63 | E2 |
| 64 | F2 |
| 65 | G2 |
| 66 | H1 |
| 67 | H3 |
| 68 | J1 |
| 69 | K1 |
| 70 | L1 |
| 71 | M1 |
| 72 | J2 |
| 73 | K2 |
| 74 | L2 |
| 75 | M2 |
| 76 | N1 |
| 77 | N2 |
| 78 | P1 |
| 79 | R1 |
| 80 | R2 |
| 81 | P3 |
| 82 | R3 |
| 83 | P2 |
| 84 | R4 |
| 85 | P4 |
| 86 | N5 |
| 87 | P6 |
| 88 | R6 |
| 89 | Internal |

Notes

19. Balls which are NC (No Connect) are pre-set LOW.
20. Bit# 89 is pre-set HIGH.

Maximum Ratings

Exceeding the maximum ratings may impair the useful life of the device. For user guidelines, not tested.

| | |
|---|------------------------------------|
| Storage Temperature | -65 °C to +150 °C |
| Ambient Temperature with Power Applied | -55 °C to +125 °C |
| Supply Voltage on V _{DD} Relative to GND | -0.3 V to +4.6 V |
| Supply Voltage on V _{DDQ} Relative to GND | -0.3 V to +V _{DD} |
| DC Voltage Applied to Outputs in Tri-State | -0.5 V to V _{DDQ} + 0.5 V |
| DC Input Voltage | -0.5 V to V _{DD} + 0.5 V |
| Current into Outputs (LOW) | 20 mA |
| Static Discharge Voltage (per MIL-STD-883, Method 3015) | > 2001 V |
| Latch-up Current | > 200 mA |

Operating Range

| Range | Ambient Temperature | V _{DD} | V _{DDQ} |
|------------|---------------------|--------------------|-------------------------------|
| Commercial | 0 °C to +70 °C | 3.3 V – 5% / + 10% | 2.5 V – 5% to V _{DD} |
| Industrial | -40 °C to +85 °C | | |

Neutron Soft Error Immunity

| Parameter | Description | Test Conditions | Typ | Max [21] | Unit |
|-----------|---------------------------|-----------------|-----|----------|---------|
| LSBU | Logical Single-Bit Upsets | 25 °C | 361 | 394 | FIT/Mb |
| LMBU | Logical Multi-Bit Upsets | 25 °C | 0 | 0.01 | FIT/Mb |
| SEL | Single Event Latch Up | 85 °C | 0 | 0.1 | FIT/Dev |

Electrical Characteristics

Over the Operating Range

| Parameter [22, 23] | Description | Test Conditions | Min | Max | Unit | |
|-------------------------|--|---|-----------------------|-------------------------|------|----|
| V _{DD} | Power Supply Voltage | | 3.135 | 3.6 | V | |
| V _{DDQ} | I/O Supply Voltage | for 3.3 V I/O | 3.135 | V _{DD} | V | |
| | | for 2.5 V I/O | 2.375 | 2.625 | V | |
| V _{OH} | Output HIGH Voltage | for 3.3 V I/O, I _{OH} = -4.0 mA | 2.4 | - | V | |
| | | for 2.5 V I/O, I _{OH} = -1.0 mA | 2.0 | - | V | |
| V _{OL} | Output LOW Voltage | for 3.3 V I/O, I _{OL} = 8.0 mA | - | 0.4 | V | |
| | | for 2.5 V I/O, I _{OL} = 1.0 mA | - | 0.4 | V | |
| V _{IH} | Input HIGH Voltage [22] | for 3.3 V I/O | 2.0 | V _{DD} + 0.3 V | V | |
| | | for 2.5 V I/O | 1.7 | V _{DD} + 0.3 V | V | |
| V _{IL} | Input LOW Voltage [22] | for 3.3 V I/O | -0.3 | 0.8 | V | |
| | | for 2.5 V I/O | -0.3 | 0.7 | V | |
| I _X | Input Leakage Current except ZZ and MODE | GND ≤ V _I ≤ V _{DDQ} | -5 | 5 | μA | |
| | Input Current of MODE | Input = V _{SS} | -30 | - | μA | |
| | | Input = V _{DD} | - | 5 | μA | |
| | Input Current of ZZ | Input = V _{SS} | -5 | - | μA | |
| Input = V _{DD} | | - | 30 | μA | | |
| I _{OZ} | Output Leakage Current | GND ≤ V _I ≤ V _{DD} , Output Disabled | -5 | 5 | μA | |
| I _{DD} | V _{DD} Operating Supply Current | V _{DD} = Max, I _{OUT} = 0 mA, f = f _{MAX} = 1/t _{CYC} | 7.5 ns cycle, 133 MHz | - | 210 | mA |
| | | | 10 ns cycle, 100 MHz | - | 175 | mA |

Notes

21. No LMBU or SEL events occurred during testing; this column represents a statistical c2, 95% confidence limit calculation. For more details refer to Application Note AN54908, Accelerated Neutron SER Testing and Calculation of Terrestrial Failure Rates.

22. Overshoot: V_{IH(AC)} < V_{DD} + 1.5 V (pulse width less than t_{CYC}/2), undershoot: V_{IL(AC)} > -2 V (pulse width less than t_{CYC}/2).

23. T_{power up}: Assumes a linear ramp from 0 V to V_{DD(min)} within 200 ms. During this time V_{IH} < V_{DD} and V_{DDQ} ≤ V_{DD}.

Electrical Characteristics *(continued)*

Over the Operating Range

| Parameter ^[22, 23] | Description | Test Conditions | Min | Max | Unit | |
|-------------------------------|---|---|-----------------------|-----|------|----|
| I _{SB1} | Automatic CE power-down Current – TTL Inputs | Max V _{DD} , Device Deselected, V _{IN} ≥ V _{IH} or V _{IN} ≤ V _{IL} , f = f _{MAX} , inputs switching | 7.5 ns cycle, 133 MHz | – | 140 | mA |
| | | | 10 ns cycle, 100 MHz | – | 120 | |
| I _{SB2} | Automatic CE power-down Current – CMOS Inputs | Max V _{DD} , Device Deselected, V _{IN} ≥ V _{DD} – 0.3 V or V _{IN} ≤ 0.3 V, f = 0, inputs static | All speeds | – | 70 | mA |
| I _{SB3} | Automatic CE power-down Current – CMOS Inputs | Max V _{DD} , Device Deselected, V _{IN} ≥ V _{DDQ} – 0.3 V or V _{IN} ≤ 0.3 V, f = f _{MAX} , inputs switching | 7.5 ns cycle, 133 MHz | – | 130 | mA |
| | | | 10 ns cycle, 100 MHz | – | 110 | |
| I _{SB4} | Automatic CE power-down Current – TTL Inputs | Max V _{DD} , Device Deselected, V _{IN} ≥ V _{DD} – 0.3 V or V _{IN} ≤ 0.3 V, f = 0, inputs static | All Speeds | – | 80 | mA |

Capacitance

| Parameter ^[24] | Description | Test Conditions | 100-pin TQFP Package | 165-ball FBGA Package | Unit |
|---------------------------|--------------------------|--|----------------------|-----------------------|------|
| C _{IN} | Input capacitance | T _A = 25 °C, f = 1 MHz, V _{DD} = 3.3 V, V _{DDQ} = 2.5 V | 5 | 9 | pF |
| C _{CLK} | Clock input capacitance | | 5 | 9 | pF |
| C _{IO} | Input/Output capacitance | | 5 | 9 | pF |

Thermal Resistance

| Parameter ^[24] | Description | Test Conditions | 100-pin TQFP Package | 165-ball FBGA Package | Unit |
|---------------------------|--|---|----------------------|-----------------------|------|
| Θ _{JA} | Thermal resistance (junction to ambient) | Test conditions follow standard test methods and procedures for measuring thermal impedance, in accordance with EIA/JESD51. | 28.66 | 20.7 | °C/W |
| Θ _{JC} | Thermal resistance (junction to case) | | 4.08 | 4.0 | °C/W |

Note

24. Tested initially and after any design or process change that may affect these parameters.

AC Test Loads and Waveforms

Figure 4. AC Test Loads and Waveforms

3.3 V I/O Test Load

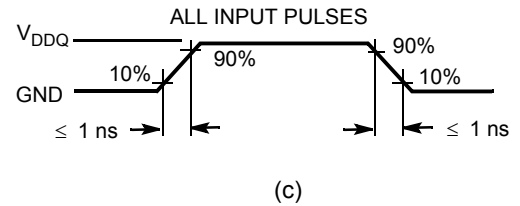
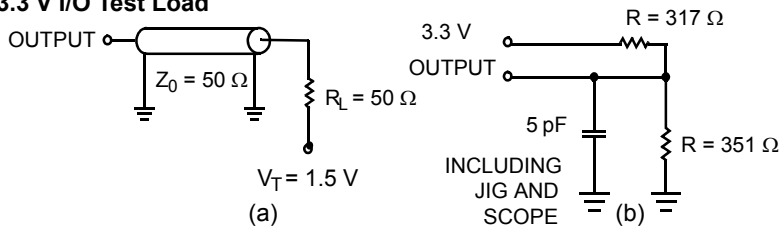

2.5 V I/O Test Load

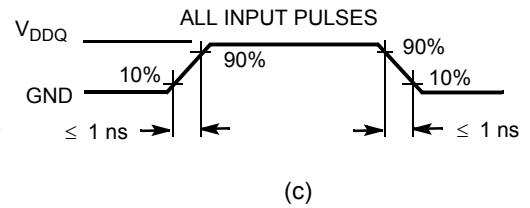
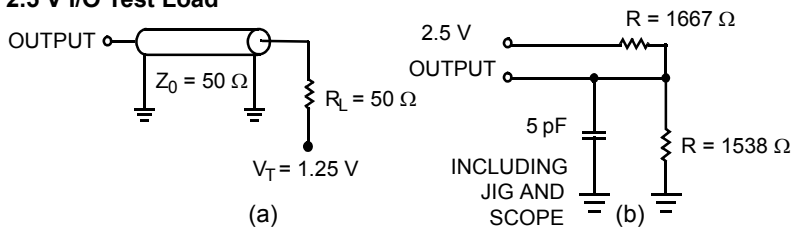

Switching Characteristics

Over the Operating Range

| Parameter ^[25, 26] | Description | 133 MHz | | 100 MHz | | Unit |
|-------------------------------|--|---------|-----|---------|-----|------|
| | | Min | Max | Min | Max | |
| t _{POWER} | V _{DD} (typical) to the first access ^[27] | 1 | – | 1 | – | ms |
| Clock | | | | | | |
| t _{CYC} | Clock cycle time | 7.5 | – | 10 | – | ns |
| t _{CH} | Clock HIGH | 2.1 | – | 2.5 | – | ns |
| t _{CL} | Clock LOW | 2.1 | – | 2.5 | – | ns |
| Output Times | | | | | | |
| t _{CDV} | Data output valid after CLK rise | – | 6.5 | – | 8.5 | ns |
| t _{DOH} | Data output hold after CLK rise | 2.0 | – | 2.0 | – | ns |
| t _{CLZ} | Clock to low Z ^[28, 29, 30] | 2.0 | – | 2.0 | – | ns |
| t _{CHZ} | Clock to high Z ^[28, 29, 30] | 0 | 4.0 | 0 | 5.0 | ns |
| t _{OEV} | $\overline{\text{OE}}$ LOW to output valid | – | 3.2 | – | 3.8 | ns |
| t _{OELZ} | $\overline{\text{OE}}$ LOW to output low Z ^[28, 29, 30] | 0 | – | 0 | – | ns |
| t _{OEHZ} | $\overline{\text{OE}}$ HIGH to output high Z ^[28, 29, 30] | – | 4.0 | – | 5.0 | ns |
| Setup Times | | | | | | |
| t _{AS} | Address setup before CLK rise | 1.5 | – | 1.5 | – | ns |
| t _{ADS} | ADSP, ADSC setup before CLK rise | 1.5 | – | 1.5 | – | ns |
| t _{ADVS} | $\overline{\text{ADV}}$ setup before CLK rise | 1.5 | – | 1.5 | – | ns |
| t _{WES} | $\overline{\text{GW}}$, $\overline{\text{BWE}}$, $\overline{\text{BW}}_{[\text{A:D}]}$ setup before CLK rise | 1.5 | – | 1.5 | – | ns |
| t _{DS} | Data input setup before CLK rise | 1.5 | – | 1.5 | – | ns |
| t _{CES} | Chip enable setup | 1.5 | – | 1.5 | – | ns |
| Hold Times | | | | | | |
| t _{AH} | Address hold after CLK rise | 0.5 | – | 0.5 | – | ns |
| t _{ADH} | ADSP, ADSC hold after CLK rise | 0.5 | – | 0.5 | – | ns |
| t _{WEH} | $\overline{\text{GW}}$, $\overline{\text{BWE}}$, $\overline{\text{BW}}_{[\text{A:D}]}$ hold after CLK rise | 0.5 | – | 0.5 | – | ns |
| t _{ADVH} | $\overline{\text{ADV}}$ hold after CLK rise | 0.5 | – | 0.5 | – | ns |
| t _{DH} | Data input hold after CLK rise | 0.5 | – | 0.5 | – | ns |
| t _{CEH} | Chip enable hold after CLK rise | 0.5 | – | 0.5 | – | ns |

Notes

25. Timing reference level is 1.5 V when V_{DDQ} = 3.3 V and is 1.25 V when V_{DDQ} = 2.5 V.

26. Test conditions shown in (a) of [Figure 4 on page 22](#) unless otherwise noted.

27. This part has a voltage regulator internally; t_{POWER} is the time that the power needs to be supplied above V_{DD(minimum)} initially, before a read or write operation can be initiated.

28. t_{CHZ}, t_{CLZ}, t_{OELZ}, and t_{OEHZ} are specified with AC test conditions shown in part (b) of [Figure 4 on page 22](#). Transition is measured ±200 mV from steady-state voltage

29. At any given voltage and temperature, t_{OEHZ} is less than t_{OELZ} and t_{CHZ} is less than t_{CLZ} to eliminate bus contention between SRAMs when sharing the same data bus. These specifications do not imply a bus contention condition, but reflect parameters guaranteed over worst case user conditions. Device is designed to achieve high Z prior to low Z under the same system condition.

30. This parameter is sampled and not 100% tested.

Timing Diagrams

Figure 5. Read Cycle Timing ^[31]

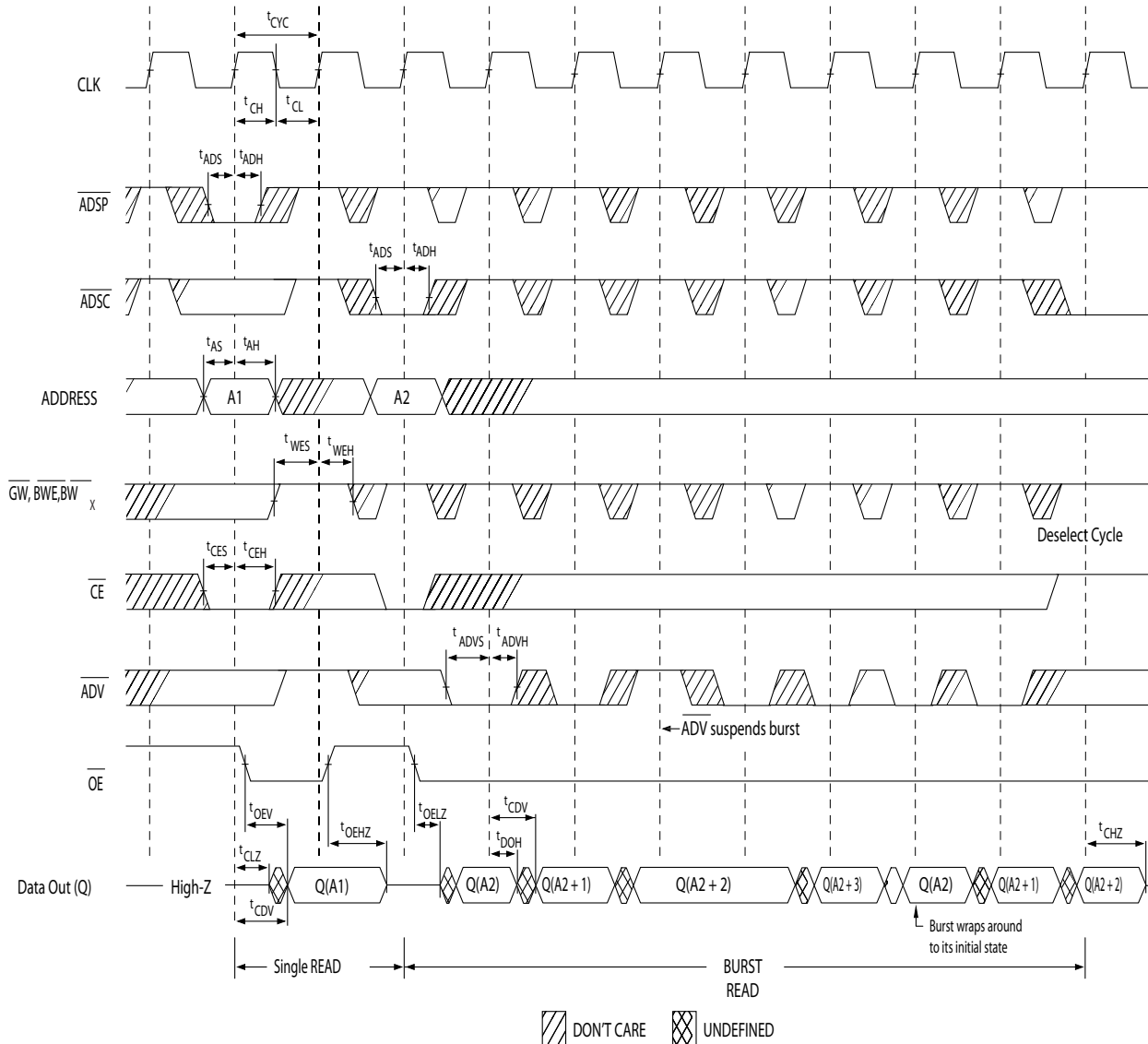

Note

31. When \overline{CE} is LOW, \overline{CE}_1 is LOW, CE_2 is HIGH and \overline{CE}_3 is LOW. When \overline{CE} is HIGH, \overline{CE}_1 is HIGH or CE_2 is LOW or \overline{CE}_3 is HIGH.

Timing Diagrams (continued)

Figure 6. Write Cycle Timing [32, 33]

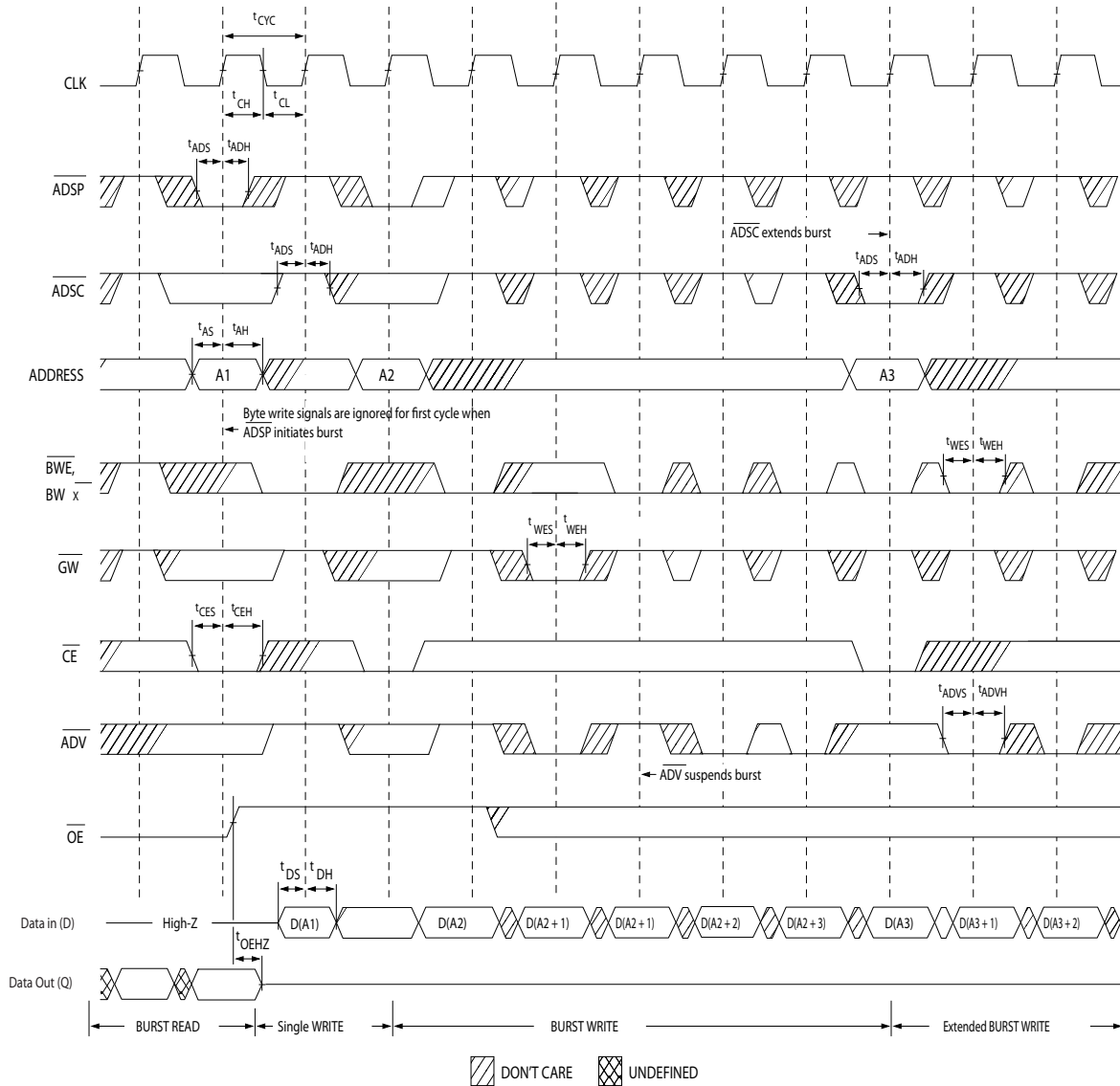

Notes

- 32. When \overline{CE} is LOW, \overline{CE}_1 is LOW, CE_2 is HIGH and \overline{CE}_3 is LOW. When \overline{CE} is HIGH, \overline{CE}_1 is HIGH or CE_2 is LOW or \overline{CE}_3 is HIGH.
- 33. Full width write can be initiated by either \overline{GW} LOW; or by \overline{GW} HIGH, \overline{BWE} LOW and \overline{BW}_x LOW.

Timing Diagrams (continued)

Figure 7. Read/Write Cycle Timing [34, 35, 36]

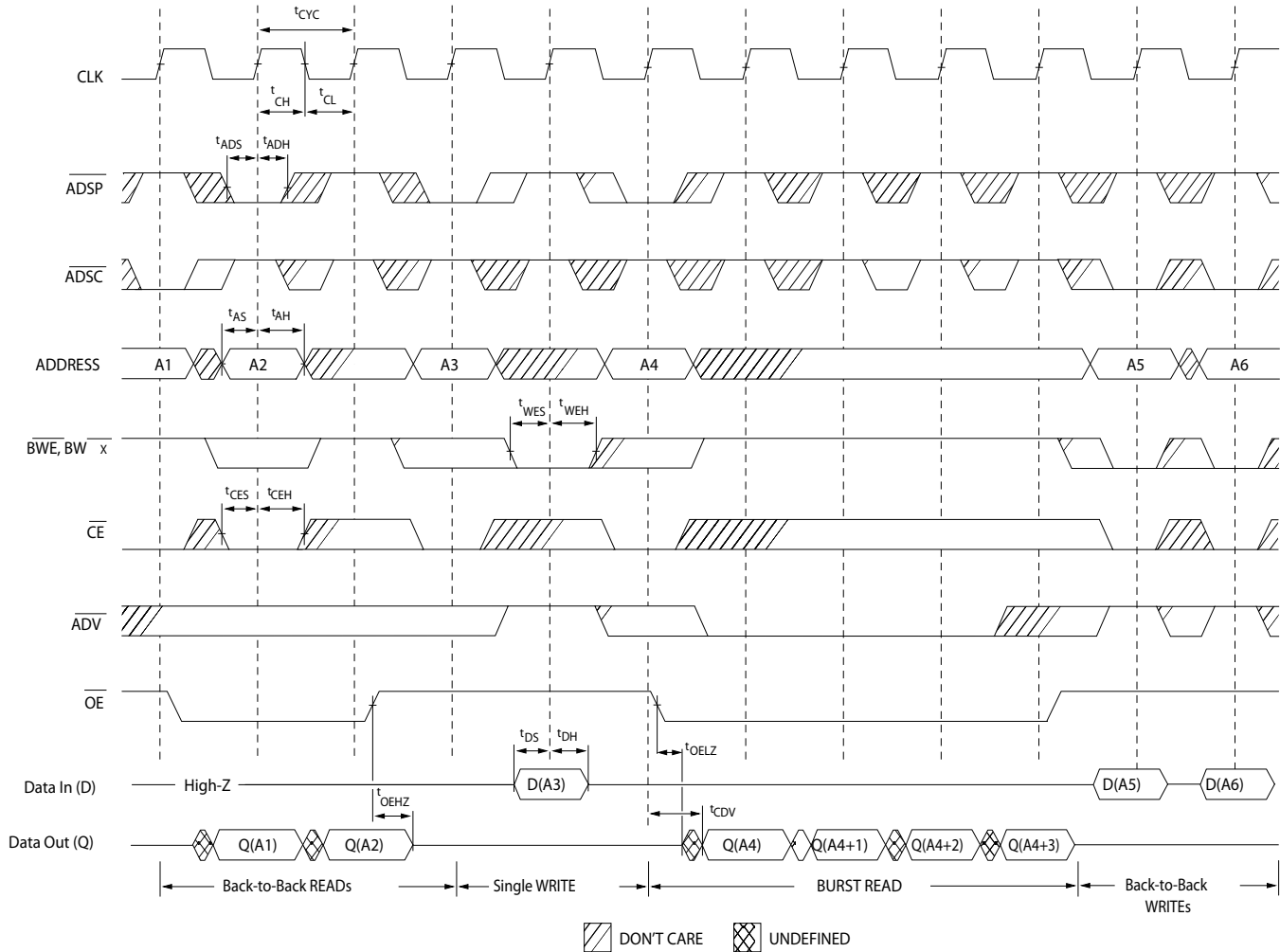

Notes

34. When \overline{CE} is LOW, \overline{CE}_1 is LOW, CE_2 is HIGH and \overline{CE}_3 is LOW. When \overline{CE} is HIGH, \overline{CE}_1 is HIGH or CE_2 is LOW or \overline{CE}_3 is HIGH.
 35. The data bus (Q) remains in high Z following a WRITE cycle, unless a new read access is initiated by ADSP or ADSC.
 36. GW is HIGH.

Timing Diagrams (continued)

Figure 8. ZZ Mode Timing [37, 38]

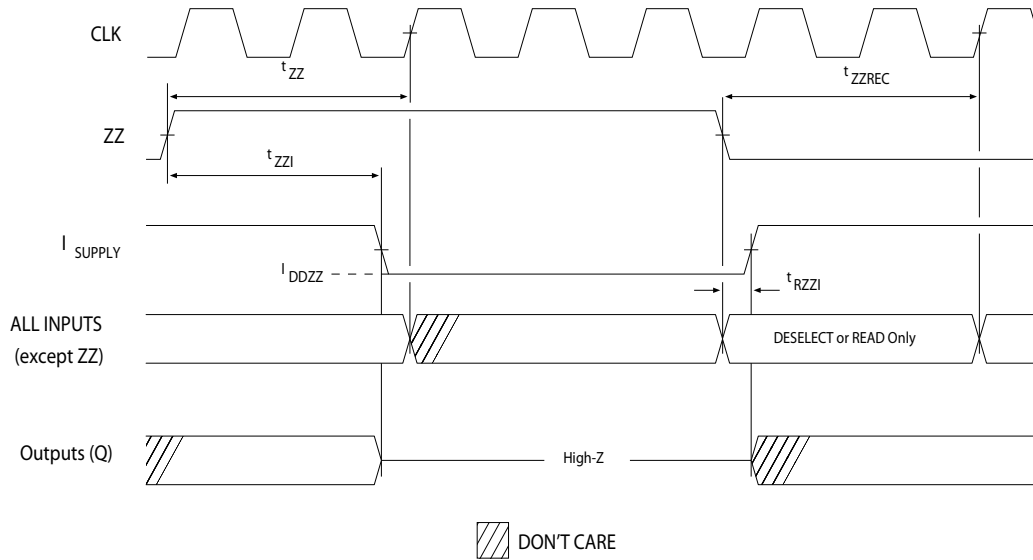

Notes

- 37. Device must be deselected when entering ZZ mode. See [Truth Table on page 10](#) for all possible signal conditions to deselect the device.
- 38. DQs are in high Z when exiting ZZ sleep mode.

Ordering Information

Cypress offers other versions of this type of product in many different configurations and features. The below table contains only the list of parts that are currently available. For a complete listing of all options, visit the Cypress website at www.cypress.com and refer to the product summary page at <http://www.cypress.com/products> or contact your local sales representative. Cypress maintains a worldwide network of offices, solution centers, manufacturer's representatives and distributors. To find the office closest to you, visit us at <http://www.cypress.com/go/datasheet/offices>.

| Speed (MHz) | Ordering Code | Package Diagram | Part and Package Type | Operating Range |
|-------------|-------------------|-----------------|--|-----------------|
| 133 | CY7C1381D-133AXC | 51-85050 | 100-pin TQFP (14 × 20 × 1.4 mm) Pb-free | Commercial |
| | CY7C1383D-133AXC | | | |
| | CY7C1381D-133AXI | | | Industrial |
| | CY7C1383D-133AXI | | | |
| | CY7C1383F-133BZI | 51-85180 | 165-ball FBGA (13 × 15 × 1.4 mm) | |
| 100 | CY7C1381D-100AXC | 51-85050 | 100-pin TQFP (14 × 20 × 1.4 mm) Pb-free | Commercial |
| | CY7C1381D-100BZI | 51-85180 | 165-ball FBGA (13 × 15 × 1.4 mm) | Industrial |
| | CY7C1381D-100BZXI | | 165-ball FBGA (13 × 15 × 1.4 mm) Pb-free | |

Ordering Code Definitions

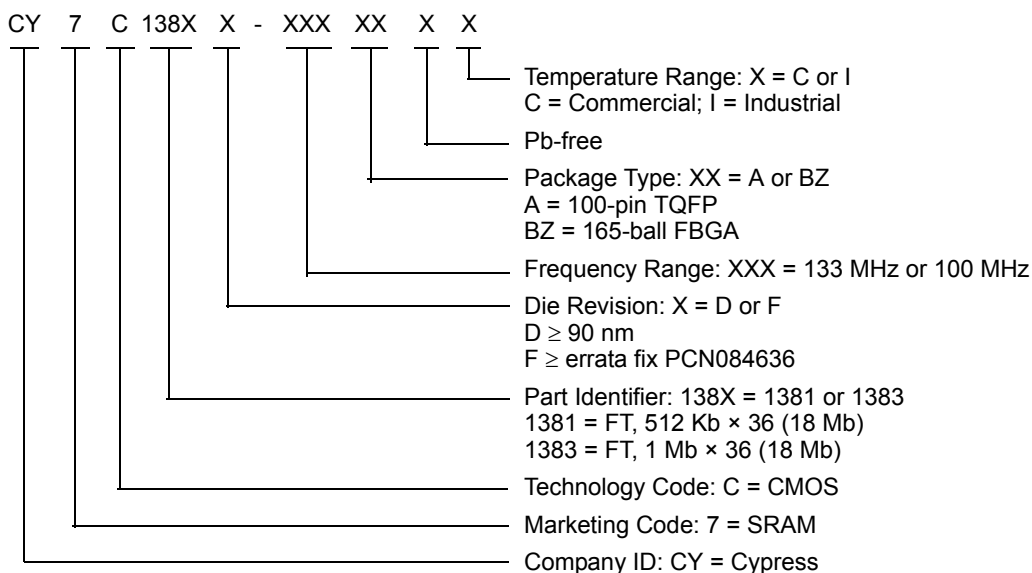

Package Diagrams

Figure 9. 100-pin TQFP (14 × 20 × 1.4 mm) A100RA Package Outline, 51-85050

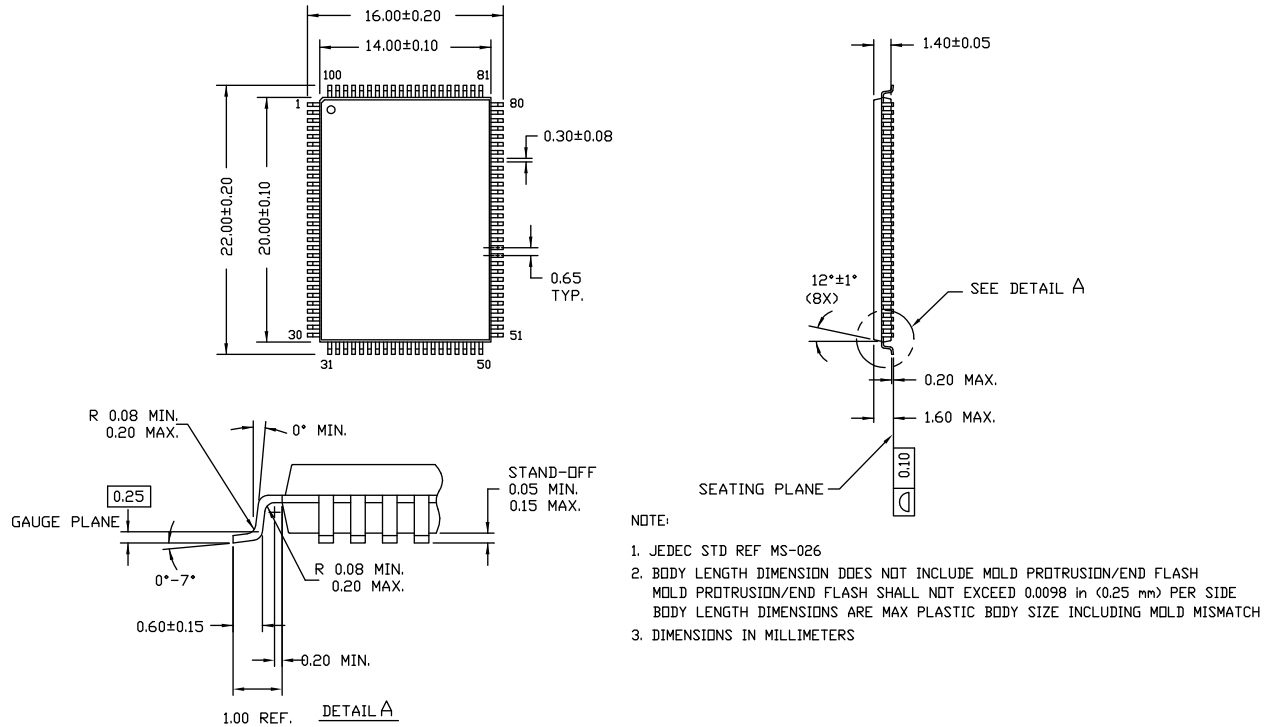

51-85050 *D

Package Diagrams (continued)

Figure 10. 165-ball FBGA (13 × 15 × 1.4 mm) BB165D/BW165D (0.5 Ball Diameter) Package Outline, 51-85180

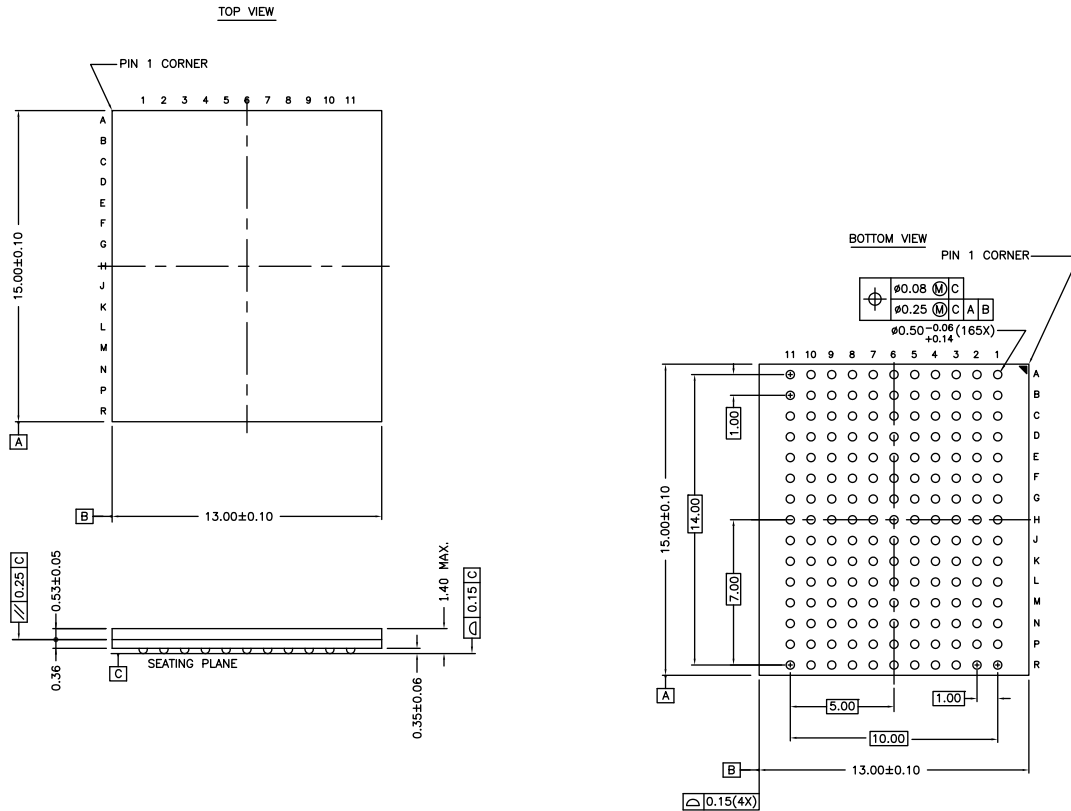

NOTES :
 SOLDER PAD TYPE : NON-SOLDER MASK DEFINED (NSMD)
 JEDEC REFERENCE : MO-216 / ISSUE E
 PACKAGE CODE : BB0AC/BW0AC
 PACKAGE WEIGHT : SEE CYPRESS PACKAGE MATERIAL DECLARATION
 DATASHEET (PMDD) POSTED ON THE CYPRESS WEB.

51-85180 *F

Acronyms

| Acronym | Description |
|-----------------|--|
| CE | Chip Enable |
| CMOS | Complementary Metal Oxide Semiconductor |
| EIA | Electronic Industries Alliance |
| FBGA | Fine-Pitch Ball Grid Array |
| I/O | Input/Output |
| JEDEC | Joint Electron Devices Engineering Council |
| JTAG | Joint Test Action Group |
| LMBU | Logical Multi-Bit Upsets |
| LSB | Least Significant Bit |
| LSBU | Logical Single-Bit Upsets |
| MSB | Most Significant Bit |
| \overline{OE} | Output Enable |
| SEL | Single Event Latch Up |
| SRAM | Static Random Access Memory |
| TAP | Test Access Port |
| TCK | Test Clock |
| TDI | Test Data-In |
| TDO | Test Data-Out |
| TMS | Test Mode Select |
| TQFP | Thin Quad Flat Pack |
| TTL | Transistor-Transistor Logic |

Document Conventions

Units of Measure

| Symbol | Unit of Measure |
|--------|-----------------|
| °C | degree Celsius |
| MHz | megahertz |
| μA | microampere |
| mA | milliampere |
| mm | millimeter |
| ms | millisecond |
| mV | millivolt |
| ns | nanosecond |
| Ω | ohm |
| % | percent |
| pF | picofarad |
| V | volt |
| W | watt |

Errata

This section describes the Ram9 Sync ZZ pin and JTAG issues. Details include trigger conditions, the devices affected, proposed workaround and silicon revision applicability. Please contact your local Cypress sales representative if you have further questions.

Part Numbers Affected

| Density & Revision | Package Type | Operating Range |
|---|---------------|---------------------------|
| 18Mb-Ram9 Synchronous SRAMs: CY7C138*D, CY7C138*F | 100-pin TQFP | Commercial/ Industrial |
| | 165-ball FBGA | Industrial |

Product Status

All of the devices in the Ram9 18Mb Sync family are qualified and available in production quantities.

Ram9 Sync ZZ Pin & JTAG Issues Errata Summary

The following table defines the errata applicable to available Ram9 18Mb Sync family devices.

| Item | Issues | Description | Device | Fix Status |
|------|--------------------|--|------------------|---|
| 1. | ZZ Pin | When asserted HIGH, the ZZ pin places device in a "sleep" condition with data integrity preserved. The ZZ pin currently does not have an internal pull-down resistor and hence cannot be left floating externally by the user during normal mode of operation. | 18M-Ram9 (90 nm) | For the 18M Ram9 (90 nm) devices, there is no plan to fix this issue. |
| 2. | JTAG Functionality | During JTAG test mode, the Boundary scan circuitry does not perform as described in the datasheet. However, it is possible to perform the JTAG test with these devices in "BYPASS mode". | 18M-Ram9 (90 nm) | This issue will be fixed in the new revision, which use the 65 nm technology. Please contact your local sales rep for availability. |

1. ZZ Pin Issue

■ PROBLEM DEFINITION

The problem occurs only when the device is operated in the normal mode with ZZ pin left floating. The ZZ pin on the SRAM device does not have an internal pull-down resistor. Switching noise in the system may cause the SRAM to recognize a HIGH on the ZZ input, which may cause the SRAM to enter sleep mode. This could result in incorrect or undesirable operation of the SRAM.

■ TRIGGER CONDITIONS

Device operated with ZZ pin left floating.

■ SCOPE OF IMPACT

When the ZZ pin is left floating, the device delivers incorrect data.

■ WORKAROUND

Tie the ZZ pin externally to ground.

■ FIX STATUS

For the 18M Ram9 (90 nm) devices, there is no plan to fix this issue.

2. JTAG Functionality

■ PROBLEM DEFINITION

The problem occurs only when the device is operated in the JTAG test mode. During this mode, the JTAG circuitry can perform incorrectly by delivering the incorrect data or the incorrect scan chain length.

■ TRIGGER CONDITIONS

Several conditions can trigger this failure mode.

1. The device can deliver an incorrect length scan chain when operating in JTAG mode.
2. Some Byte Write inputs only recognize a logic HIGH level when in JTAG mode.
3. Incorrect JTAG data can be read from the device when the ZZ input is tied HIGH during JTAG operation.

■ SCOPE OF IMPACT

The device fails for JTAG test. This does not impact the normal functionality of the device.

■ WORKAROUND

1. Perform JTAG testing with these devices in "BYPASS mode".
2. Do not use JTAG test.

■ FIX STATUS

This issue will be fixed in the new revision, which use the 65 nm technology. Please contact your local sales rep for availability.

Document History Page

| Document Title: CY7C1381D/CY7C1383D/CY7C1383F, 18-Mbit (512 K × 36/1 M × 18) Flow-Through SRAM | | | | |
|--|---------|-----------------|-----------------|---|
| Document Number: 38-05544 | | | | |
| Rev. | ECN No. | Orig. of Change | Submission Date | Description of Change |
| ** | 254518 | RKF | See ECN | New data sheet |
| *A | 288531 | SYT | See ECN | Updated Features (Removed 117 MHz speed bin). Updated Selection Guide (Removed 117 MHz speed bin). Updated IEEE 1149.1 Serial Boundary Scan (JTAG [14]) (Edited description for non-compliance with 1149.1) Updated Electrical Characteristics (Removed 117 MHz speed bin). Updated Switching Characteristics (Removed 117 MHz speed bin). Updated Ordering Information (Added Pb-free information for 100-pin TQFP, 119-ball BGA and 165-ball FBGA package) and added comment of 'Pb-free BG packages availability' below the Ordering Information. |
| *B | 326078 | PCI | See ECN | Changed status from Preliminary to Final. Updated Pin Configurations (Address expansion pins/balls in the pinouts for all packages are modified as per JEDEC standard). Updated TAP Instruction Set (Changed description of OVERVIEW and EXTTEST sub-sections, added a sub-section EXTTEST Output Bus Tri-State). Updated Identification Register Definitions (Splitted Device Width (23:18) row into two rows Device Width (23:18) 119-ball BGA and another row Device Width (23:18) 165-ball FBGA). Updated Electrical Characteristics (Modified test conditions for V_{OL} , V_{OH} parameters). Updated Thermal Resistance (Changed θ_{JA} for 100-pin TQFP Package from 31 °C/W to 28.66 °C/W, changed θ_{JC} for 100-pin TQFP Package from 6 °C/W to 4.08 °C/W, changed θ_{JA} for 119-ball BGA Package from 45 °C/W to 23.8 °C/W, changed θ_{JC} for 119-ball BGA Package from 7 °C/W to 6.2 °C/W, changed θ_{JA} for 165-ball FBGA Package from 46 °C/W to 20.7 °C/W, changed θ_{JC} for 165-ball FBGA Package from 3 °C/W to 4.0 °C/W). Updated Ordering Information (Updated part numbers) and removed comment of 'Pb-free BG packages availability' below the Ordering Information. |
| *C | 351895 | PCI | See ECN | Updated Ordering Information (Updated part numbers). |
| *D | 416321 | NXR | See ECN | Changed address of Cypress Semiconductor Corporation on Page# 1 from "3901 North First Street" to "198 Champion Court" Updated Electrical Characteristics (Changed description of I_X parameter from Input Load Current to Input Leakage Current, changed the minimum value of I_X parameter corresponding to Input Current of MODE from -5 µA to -30 µA, changed the maximum value of I_X parameter corresponding to Input Current of MODE from 30 µA to 5 µA, changed the minimum value of I_X parameter corresponding to Input Current of ZZ from -30 µA to -5 µA, changed the minimum value of I_X parameter corresponding to Input Current of ZZ from 5 µA to 30 µA, Changed $V_{IH} \leq V_{DD}$ to $V_{IH} < V_{DD}$ in Note 23). Updated Ordering Information (Updated part numbers) and replaced Package Name column with Package Diagram in the Ordering Information table. |
| *E | 475009 | VKN | See ECN | Updated TAP AC Switching Characteristics (Changed the minimum values of t_{TH} , t_{TL} parameters from 25 ns to 20 ns and changed the maximum value of t_{TDOV} parameter from 5 ns to 10 ns). Updated Maximum Ratings (Added the Maximum Rating for Supply Voltage on V_{DDQ} Relative to GND). Updated Ordering Information (Updated part numbers). |
| *F | 776456 | VKN | See ECN | Added part numbers CY7C1381F and CY7C1383F and its related information. Added Note 1 regarding Chip Enable. Updated Ordering Information (Updated part numbers). |

Document History Page (continued)

| Document Title: CY7C1381D/CY7C1383D/CY7C1383F, 18-Mbit (512 K × 36/1 M × 18) Flow-Through SRAM Document Number: 38-05544 | | | | |
|---|---------|-----------------|-----------------|---|
| Rev. | ECN No. | Orig. of Change | Submission Date | Description of Change |
| *G | 2752731 | VKN / PYRS | 08/17/09 | Added Neutron Soft Error Immunity . Updated Ordering Information (By including parts that are available) and modified the disclaimer for the Ordering information. |
| *H | 2897182 | NJY | 03/22/2010 | Updated Ordering Information (Removed inactive parts). Updated Package Diagrams . |
| *I | 3159479 | NJY | 02/01/2011 | Updated Package Diagrams . Added Acronyms and Units of Measure . Minor edits and updated in new template. |
| *J | 3192403 | NJY | 03/10/2011 | Updated in new template. |
| *K | 3210400 | NJY | 03/30/2011 | Updated Ordering Information (Removed pruned part CY7C1381F-133BGC). |
| *L | 3440174 | NJY | 11/16/2011 | Updated Ordering Information (Added two part numbers CY7C1383D-133AXC and CY7C1383D-133AXI). |
| *M | 3489571 | NJY | 01/10/2012 | Updated Ordering Information (Added part number CY7C1383F-133BZI). Updated Package Diagrams . |
| *N | 3578427 | PRIT | 04/11/2012 | Updated Features (Removed CY7C1381F related information, removed 119-ball BGA package related information, removed 165-ball FBGA package related information for CY7C1383D, added 165-ball FBGA package related information for CY7C1383F). Updated Functional Description (Removed CY7C1381F related information, removed the Note "For best practices or recommendations, refer to the Cypress application note AN1064, <i>SRAM System Design Guidelines</i> on www.cypress.com ." and its reference, removed the Note "CE ₃ , CE ₂ are for 100-pin TQFP and 165-ball FBGA packages only. 119-ball BGA is offered only in 1 chip enable."). Updated Logic Block Diagram – CY7C1381D (Removed CY7C1381F related information). Updated Pin Configurations (Removed CY7C1381F related information, removed 119-ball BGA package related information, removed 165-ball FBGA package related information for CY7C1383D, added 165-ball FBGA package related information for CY7C1383F). Updated Pin Definitions (Removed the Note "CE ₃ , CE ₂ are for 100-pin TQFP and 165-ball FBGA packages only. 119-ball BGA is offered only in 1 chip enable." and its reference). Updated Functional Overview (Removed CY7C1381F related information, removed the Note "CE ₃ , CE ₂ are for 100-pin TQFP and 165-ball FBGA packages only. 119-ball BGA is offered only in 1 chip enable." and its reference). Updated Truth Table (Removed CY7C1381F related information). Updated Truth Table for Read/Write (Removed CY7C1381F related information). Updated IEEE 1149.1 Serial Boundary Scan (JTAG [14]) (Removed CY7C1381F and CY7C1383D related information). Updated Identification Register Definitions (Removed CY7C1381F and CY7C1383D related information, removed 119-ball BGA package related information). Updated Scan Register Sizes (Removed 119-ball BGA package related information). Removed Boundary Scan Order (Corresponding to 119-ball BGA package). Updated Capacitance (Removed 119-ball BGA package related information). Updated Thermal Resistance (Removed 119-ball BGA package related information). Updated Package Diagrams (Removed 119-ball BGA package related information). |

Document History Page *(continued)*

| Document Title: CY7C1381D/CY7C1383D/CY7C1383F, 18-Mbit (512 K × 36/1 M × 18) Flow-Through SRAM Document Number: 38-05544 | | | | |
|---|---------|-----------------|-----------------|---|
| Rev. | ECN No. | Orig. of Change | Submission Date | Description of Change |
| *O | 3945784 | PRIT | 03/27/2013 | Updated Package Diagrams : spec 51-85180 – Changed revision from *E to *F. |
| *P | 3977530 | PRIT | 04/22/2013 | Added Errata . |
| *Q | 4068739 | PRIT | 07/20/2013 | Added Errata footnotes (Note 2, 3, 4, 5, 6, 14). Updated Pin Configurations : Added Note 2 and referred the same note in Figure 1 . Added Note 3, 4 and referred the same note in Figure 2 . Updated Pin Definitions : Added Note 5 and referred the same note in ZZ pin. Added Note 6 and referred the same note in TDO, TDI, TMS, TCK pins. Updated IEEE 1149.1 Serial Boundary Scan (JTAG [14]) : Added Note 14 and referred the same note in JTAG in the heading. Updated Errata . Updated in new template. |
| *R | 4150971 | PRIT | 10/08/2013 | Updated Errata . |

Sales, Solutions, and Legal Information

Worldwide Sales and Design Support

Cypress maintains a worldwide network of offices, solution centers, manufacturer's representatives, and distributors. To find the office closest to you, visit us at [Cypress Locations](#).

Products

| | |
|--|--|
| Automotive | cypress.com/go/automotive |
| Clocks & Buffers | cypress.com/go/clocks |
| Interface | cypress.com/go/interface |
| Lighting & Power Control | cypress.com/go/powerpsoc cypress.com/go/plc |
| Memory | cypress.com/go/memory |
| PSoC | cypress.com/go/psoc |
| Touch Sensing | cypress.com/go/touch |
| USB Controllers | cypress.com/go/USB |
| Wireless/RF | cypress.com/go/wireless |

PSoC® Solutions

[psoc.cypress.com/solutions](#)
[PSoC 1](#) | [PSoC 3](#) | [PSoC 4](#) | [PSoC 5LP](#)

Cypress Developer Community

[Community](#) | [Forums](#) | [Blogs](#) | [Video](#) | [Training](#)

Technical Support

[cypress.com/go/support](#)

© Cypress Semiconductor Corporation, 2004-2013. The information contained herein is subject to change without notice. Cypress Semiconductor Corporation assumes no responsibility for the use of any circuitry other than circuitry embodied in a Cypress product. Nor does it convey or imply any license under patent or other rights. Cypress products are not warranted nor intended to be used for medical, life support, life saving, critical control or safety applications, unless pursuant to an express written agreement with Cypress. Furthermore, Cypress does not authorize its products for use as critical components in life-support systems where a malfunction or failure may reasonably be expected to result in significant injury to the user. The inclusion of Cypress products in life-support systems application implies that the manufacturer assumes all risk of such use and in doing so indemnifies Cypress against all charges.

Any Source Code (software and/or firmware) is owned by Cypress Semiconductor Corporation (Cypress) and is protected by and subject to worldwide patent protection (United States and foreign), United States copyright laws and international treaty provisions. Cypress hereby grants to licensee a personal, non-exclusive, non-transferable license to copy, use, modify, create derivative works of, and compile the Cypress Source Code and derivative works for the sole purpose of creating custom software and or firmware in support of licensee product to be used only in conjunction with a Cypress integrated circuit as specified in the applicable agreement. Any reproduction, modification, translation, compilation, or representation of this Source Code except as specified above is prohibited without the express written permission of Cypress.

Disclaimer: CYPRESS MAKES NO WARRANTY OF ANY KIND, EXPRESS OR IMPLIED, WITH REGARD TO THIS MATERIAL, INCLUDING, BUT NOT LIMITED TO, THE IMPLIED WARRANTIES OF MERCHANTABILITY AND FITNESS FOR A PARTICULAR PURPOSE. Cypress reserves the right to make changes without further notice to the materials described herein. Cypress does not assume any liability arising out of the application or use of any product or circuit described herein. Cypress does not authorize its products for use as critical components in life-support systems where a malfunction or failure may reasonably be expected to result in significant injury to the user. The inclusion of Cypress' product in a life-support systems application implies that the manufacturer assumes all risk of such use and in doing so indemnifies Cypress against all charges.

Use may be limited by and subject to the applicable Cypress software license agreement.



LittleDiode supplies new, hard to find or obsolete electronic components and semiconductors all over the world.

With over two million different components listed you are sure to find the part you need.

Feel free to visit us today at our online store:

LittleDiode.com

Looking forward to providing you with the best possible service.