

# 32K x 8 3.3V Static RAM

## Features

- Single 3.3V power supply
- Ideal for low-voltage cache memory applications
- High speed
  - 10/12/15 ns
- Low active power
  - 216 mW (max.)
- Low-power alpha immune 6T cell
- Plastic SOJ and TSOP packaging

## Functional Description<sup>[1]</sup>

The CY7C1399B is a high-performance 3.3V CMOS Static RAM organized as 32,768 words by 8 bits. Easy memory expansion is provided by an active LOW Chip Enable ( $\overline{CE}$ ) and

active LOW Output Enable ( $\overline{OE}$ ) and three-state drivers. The device has an automatic power-down feature, reducing the power consumption by more than 95% when deselected.

An active LOW Write Enable signal ( $\overline{WE}$ ) controls the writing/reading operation of the memory. When  $\overline{CE}$  and  $\overline{WE}$  inputs are both LOW, data on the eight data input/output pins ( $I/O_0$  through  $I/O_7$ ) is written into the memory location addressed by the address present on the address pins ( $A_0$  through  $A_{14}$ ). Reading the device is accomplished by selecting the device and enabling the outputs,  $\overline{CE}$  and  $\overline{OE}$  active LOW, while  $\overline{WE}$  remains inactive or HIGH. Under these conditions, the contents of the location addressed by the information on address pins is present on the eight data input/output pins.

The input/output pins remain in a high-impedance state unless the chip is selected, outputs are enabled, and Write Enable ( $\overline{WE}$ ) is HIGH. The CY7C1399B is available in 28-pin standard 300-mil-wide SOJ and TSOP Type I packages.

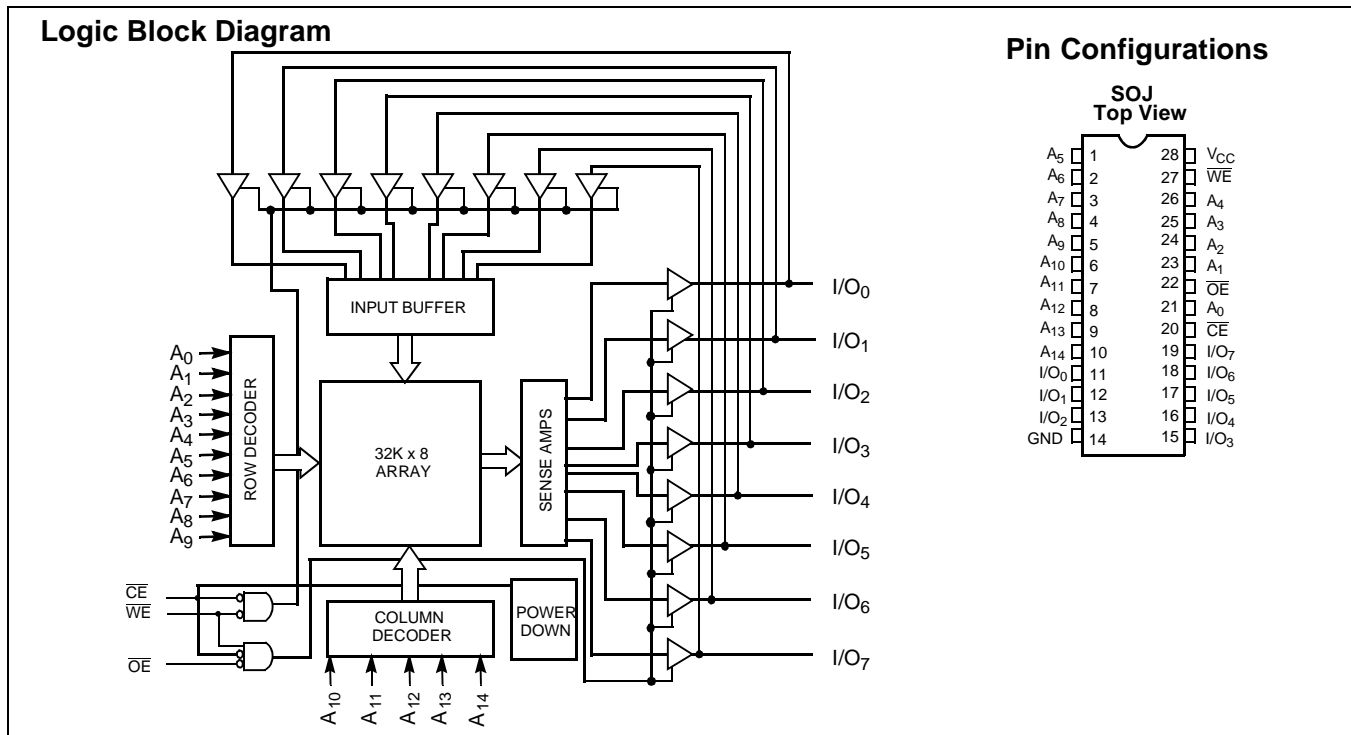

## Selection Guide

	1399B-10	1399B-12	1399B-15	1399B-20
Maximum Access Time (ns)	10	12	15	20
Maximum Operating Current (mA)	60	55	50	45
Maximum CMOS Standby Current ( $\mu$ A)	500	500	500	500
	L	50	50	50

### Note:

1. For guidelines on SRAM system design, please refer to the 'System Design Guidelines' Cypress application note, available on the internet at [www.cypress.com](http://www.cypress.com).

**Pin Configuration**
**TSOP  
Top View**

**Maximum Ratings**

(Above which the useful life may be impaired. For user guidelines, not tested.)

Storage Temperature ..... -65°C to +150°C

Ambient Temperature with Power Applied..... -55°C to +125°C

Supply Voltage on V<sub>CC</sub> to Relative GND<sup>[2]</sup> .... -0.5V to +4.6V

DC Voltage Applied to Outputs in High Z State<sup>[2]</sup> ..... -0.5V to V<sub>CC</sub> + 0.5V

DC Input Voltage<sup>[2]</sup>..... -0.5V to V<sub>CC</sub> + 0.5V

Output Current into Outputs (LOW)..... 20 mA

Static Discharge Voltage..... >2001V (per MIL-STD-883, Method 3015)

Latch-Up Current..... >200 mA

**Operating Range**

Range	Ambient Temperature	V <sub>CC</sub>
Commercial	0°C to +70°C	3.3V ±300 mV
Industrial	-40°C to +85°C	3.3V ±300 mV

**Electrical Characteristics** Over the Operating Range<sup>[1]</sup>

Parameter	Description	Test Conditions	7C1399B-10		7C1399B-12		Unit
			Min.	Max.	Min.	Max.	
V <sub>OH</sub>	Output HIGH Voltage	V <sub>CC</sub> = Min., I <sub>OH</sub> = -2.0 mA	2.4		2.4		V
V <sub>OL</sub>	Output LOW Voltage	V <sub>CC</sub> = Min., I <sub>OL</sub> = 4.0 mA		0.4		0.4	V
V <sub>IH</sub>	Input HIGH Voltage		2.2	V <sub>CC</sub> + 0.3V	2.2	V <sub>CC</sub> + 0.3V	V
V <sub>IL</sub>	Input LOW Voltage <sup>[2]</sup>		-0.3	0.8	-0.3	0.8	V
I <sub>Ix</sub>	Input Load Current		-1	+1	-1	+1	μA
I <sub>OZ</sub>	Output Leakage Current	GND ≤ V <sub>I</sub> ≤ V <sub>CC</sub> , Output Disabled	-5	+5	-5	+5	μA
I <sub>OS</sub>	Output Short Circuit Current <sup>[3]</sup>	V <sub>CC</sub> = Max., V <sub>OUT</sub> = GND		-300		-300	mA
I <sub>CC</sub>	V <sub>CC</sub> Operating Supply Current	V <sub>CC</sub> = Max., I <sub>OUT</sub> = 0 mA, f = f <sub>MAX</sub> = 1/t <sub>RC</sub>		60		55	mA
I <sub>SB1</sub>	Automatic CE Power-Down Current — TTL Inputs	Max. V <sub>CC</sub> , CE ≥ V <sub>IH</sub> , V <sub>IN</sub> ≥ V <sub>IH</sub> , or V <sub>IN</sub> ≤ V <sub>IL</sub> , f = f <sub>MAX</sub>		5		5	mA
			L	4		4	mA
I <sub>SB2</sub>	Automatic CE Power-Down Current — CMOS Inputs <sup>[4]</sup>	Max. V <sub>CC</sub> , CE ≥ V <sub>CC</sub> - 0.3V, V <sub>IN</sub> ≥ V <sub>CC</sub> - 0.3V, or V <sub>IN</sub> ≤ 0.3V, WE ≥ V <sub>CC</sub> - 0.3V or WE ≤ 0.3V, f = f <sub>MAX</sub>		500		500	μA
			L	50		50	μA

**Notes:**

- Minimum voltage is equal to -2.0V for pulse durations of less than 20 ns.
- Not more than one output should be shorted at one time. Duration of the short circuit should not exceed 30 seconds.
- Device draws low standby current regardless of switching on the addresses.

**Electrical Characteristics** Over the Operating Range (continued)

Parameter	Description	Test Conditions	1399B-15		1399B-20		Unit
			Min.	Max.	Min.	Max.	
$V_{OH}$	Output HIGH Voltage	$V_{CC} = \text{Min.}, I_{OH} = -2.0 \text{ mA}$	2.4		2.4		V
$V_{OL}$	Output LOW Voltage	$V_{CC} = \text{Min.}, I_{OL} = 4.0 \text{ mA}$		0.4		0.4	V
$V_{IH}$	Input HIGH Voltage		2.2	$V_{CC} + 0.3V$	2.2	$V_{CC} + 0.3V$	V
$V_{IL}$	Input LOW Voltage		-0.3	0.8	-0.3	0.8	V
$I_{IX}$	Input Load Current		-1	+1	-1	+1	$\mu\text{A}$
$I_{OZ}$	Output Leakage Current	$GND \leq V_I \leq V_{CC}$ , Output Disabled	-5	+5	-5	+5	$\mu\text{A}$
$I_{OS}$	Output Short Circuit Current <sup>[3]</sup>	$V_{CC} = \text{Max.}, V_{OUT} = GND$		-300		-300	mA
$I_{CC}$	$V_{CC}$ Operating Supply Current	$V_{CC} = \text{Max.}, I_{OUT} = 0 \text{ mA}$ , $f = f_{MAX} = 1/t_{RC}$		50		45	mA
$I_{SB1}$	Automatic CE Power-Down Current — TTL Inputs	Max. $V_{CC}$ , $\overline{CE} \geq V_{IH}$ , $V_{IN} \geq V_{IH}$ , or $V_{IN} \leq V_{IL}$ , $f = f_{MAX}$		5		5	mA
			L	4		4	mA
$I_{SB2}$	Automatic CE Power-Down Current — CMOS Inputs <sup>[4]</sup>	Max. $V_{CC}$ , $\overline{CE} \geq V_{CC} - 0.3V$ , $V_{IN} \geq V_{CC} - 0.3V$ , or $V_{IN} \leq 0.3V$ , $WE \geq V_{CC} - 0.3V$ or $WE \leq 0.3V$ , $f = f_{MAX}$		500		500	$\mu\text{A}$
			L	50		50	$\mu\text{A}$

**Capacitance<sup>[5]</sup>**

Parameter	Description	Test Conditions	Max.	Unit
$C_{IN}$ : Addresses	Input Capacitance	$T_A = 25^\circ\text{C}, f = 1 \text{ MHz}, V_{CC} = 3.3V$	5	pF
$C_{IN}$ : Controls			6	pF
$C_{OUT}$	Output Capacitance		6	pF

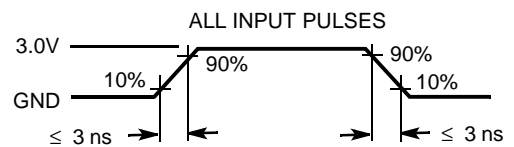
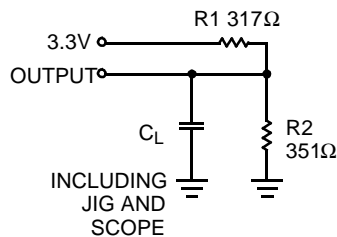
**AC Test Loads and Waveforms**

Equivalent to: THÉVENIN EQUIVALENT

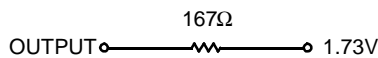
**Note:**

- Tested initially and after any design or process changes that may affect these parameters.

**Switching Characteristics** Over the Operating Range<sup>[6]</sup>

Parameter	Description	1399B-10		1399B-12		Unit
		Min.	Max.	Min.	Max.	
<b>Read Cycle</b>						
$t_{RC}$	Read Cycle Time	10		12		ns
$t_{AA}$	Address to Data Valid		10		12	ns
$t_{OHA}$	Data Hold from Address Change	3		3		ns
$t_{ACE}$	$\overline{CE}$ LOW to Data Valid		10		12	ns
$t_{DOE}$	$\overline{OE}$ LOW to Data Valid		5		5	ns
$t_{LZOE}$	$\overline{OE}$ LOW to Low Z <sup>[7]</sup>	0		0		ns
$t_{HZOE}$	$\overline{OE}$ HIGH to High Z <sup>[7, 8]</sup>		5		5	ns
$t_{LZCE}$	$\overline{CE}$ LOW to Low Z <sup>[7]</sup>	3		3		ns
$t_{HZCE}$	$\overline{CE}$ HIGH to High Z <sup>[7, 8]</sup>		5		6	ns
$t_{PU}$	$\overline{CE}$ LOW to Power-Up	0		0		ns
$t_{PD}$	$\overline{CE}$ HIGH to Power-Down		10		12	ns
<b>Write Cycle<sup>[9, 10]</sup></b>						
$t_{WC}$	Write Cycle Time	10		12		ns
$t_{SCE}$	$\overline{CE}$ LOW to Write End	8		8		ns
$t_{AW}$	Address Set-Up to Write End	7		8		ns
$t_{HA}$	Address Hold from Write End	0		0		ns
$t_{SA}$	Address Set-Up to Write Start	0		0		ns
$t_{PWE}$	$\overline{WE}$ Pulse Width	7		8		ns
$t_{SD}$	Data Set-Up to Write End	5		7		ns
$t_{HD}$	Data Hold from Write End	0		0		ns
$t_{HZWE}$	$\overline{WE}$ LOW to High Z <sup>[9]</sup>		7		7	ns
$t_{LZWE}$	$\overline{WE}$ HIGH to Low Z <sup>[7]</sup>	3		3		ns

**Notes:**

6. Test conditions assume signal transition time of 3 ns or less, timing reference levels of 1.5V, input pulse levels of 0 to 3.0V, and output loading of the specified  $I_{OL}/I_{OH}$  and capacitance  $C_L = 30$  pF.
7. At any given temperature and voltage condition,  $t_{HZCE}$  is less than  $t_{LZCE}$ ,  $t_{HZOE}$  is less than  $t_{LZOE}$ , and  $t_{HZWE}$  is less than  $t_{LZWE}$  for any given device.
8.  $t_{HZOE}$ ,  $t_{HZCE}$ ,  $t_{HZWE}$  are specified with  $C_L = 5$  pF as in AC Test Loads. Transition is measured  $\pm 500$  mV from steady state voltage.
9. The internal write time of the memory is defined by the overlap of  $\overline{CE}$  LOW and  $\overline{WE}$  LOW. Both signals must be LOW to initiate a write and either signal can terminate a write by going HIGH. The data input set-up and hold timing should be referenced to the rising edge of the signal that terminates the write.
10. The minimum write cycle time for write cycle #3 ( $\overline{WE}$  controlled,  $\overline{OE}$  LOW) is the sum of  $t_{HZWE}$  and  $t_{SD}$ .

**Switching Characteristics** Over the Operating Range<sup>[6]</sup> (Continued)

Parameter	Description	1399B-15		1399B-20		Unit
		Min.	Max.	Min.	Max.	
<b>Read Cycle</b>						
t <sub>RC</sub>	Read Cycle Time	15		20		ns
t <sub>AA</sub>	Address to Data Valid		15		20	ns
t <sub>OHA</sub>	Data Hold from Address Change	3		3		ns
t <sub>ACE</sub>	$\overline{CE}$ LOW to Data Valid		15		20	ns
t <sub>DOE</sub>	$\overline{OE}$ LOW to Data Valid		6		7	ns
t <sub>LZOE</sub>	$\overline{OE}$ LOW to Low Z <sup>[7]</sup>	0		0		ns
t <sub>HZOE</sub>	$\overline{OE}$ HIGH to High Z <sup>[7, 8]</sup>		6		6	ns
t <sub>LZCE</sub>	$\overline{CE}$ LOW to Low Z <sup>[7]</sup>	3		3		ns
t <sub>HZCE</sub>	$\overline{CE}$ HIGH to High Z <sup>[7, 8]</sup>		7		7	ns
t <sub>PU</sub>	$\overline{CE}$ LOW to Power-Up	0		0		ns
t <sub>PD</sub>	$\overline{CE}$ HIGH to Power-Down		15		20	ns
<b>Write Cycle<sup>[9, 10]</sup></b>						
t <sub>WC</sub>	Write Cycle Time	15		20		ns
t <sub>SCE</sub>	$\overline{CE}$ LOW to Write End	10		12		ns
t <sub>AW</sub>	Address Set-Up to Write End	10		12		ns
t <sub>HA</sub>	Address Hold from Write End	0		0		ns
t <sub>SA</sub>	Address Set-Up to Write Start	0		0		ns
t <sub>PWE</sub>	$\overline{WE}$ Pulse Width	10		12		ns
t <sub>SD</sub>	Data Set-Up to Write End	8		10		ns
t <sub>HD</sub>	Data Hold from Write End	0		0		ns
t <sub>HZWE</sub>	$\overline{WE}$ LOW to High Z <sup>[9]</sup>		7		7	ns
t <sub>LZWE</sub>	$\overline{WE}$ HIGH to Low Z <sup>[7]</sup>	3		3		ns

**Data Retention Characteristics** (Over the Operating Range - L version only)

Parameter	Description	Conditions	Min.	Max.	Unit
V <sub>DR</sub>	V <sub>CC</sub> for Data Retention		2.0		V
I <sub>CCDR</sub>	Data Retention Current	$V_{CC} = V_{DR} = 2.0V,$ $CE \geq V_{CC} - 0.3V,$ $V_{IN} \geq V_{CC} - 0.3V$ or $V_{IN} \leq 0.3V$	0	20	μA
t <sub>CDR</sub>	Chip Deselect to Data Retention Time		0		ns
t <sub>R</sub>	Operation Recovery Time		t <sub>RC</sub>		ns

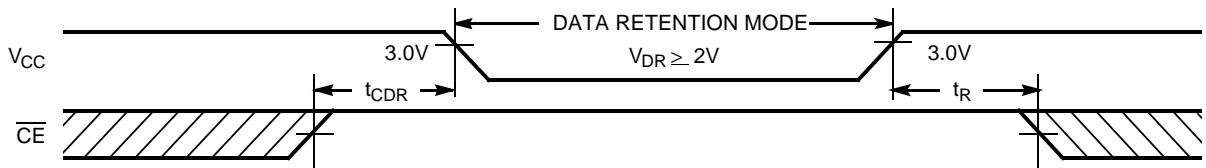
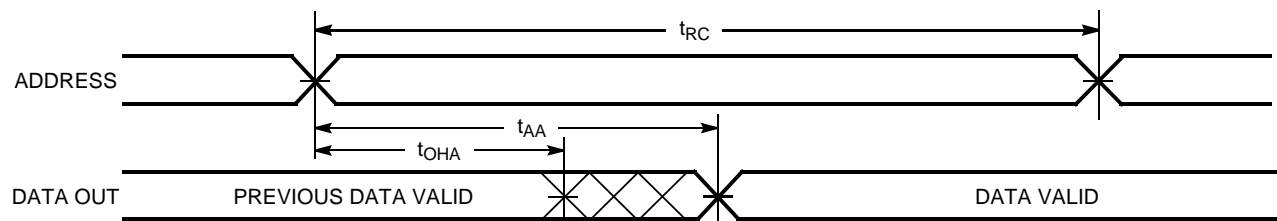
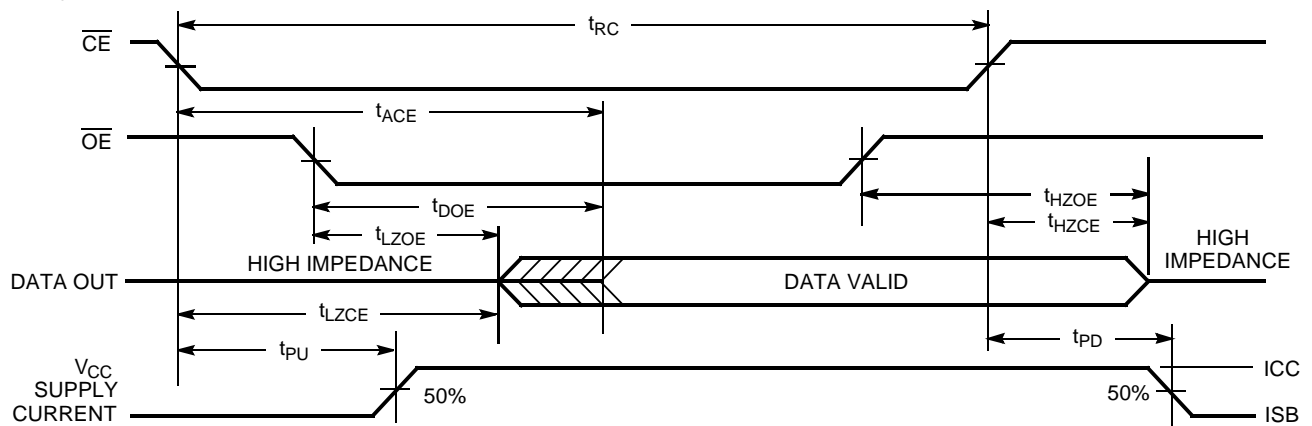
**Data Retention Waveform**

**Switching Waveforms**
**Read Cycle No. 1<sup>[11, 12]</sup>**

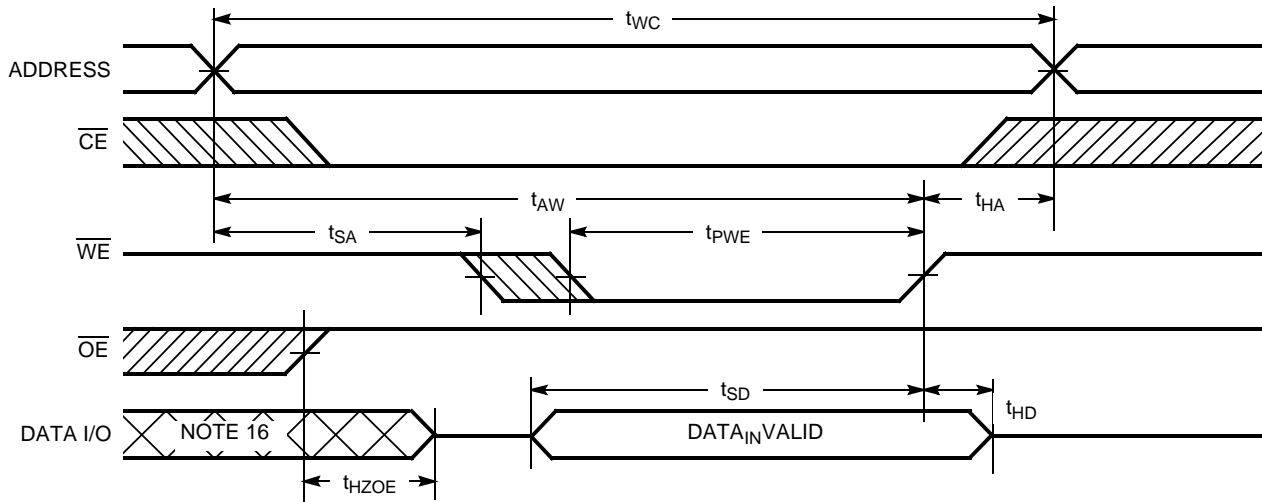
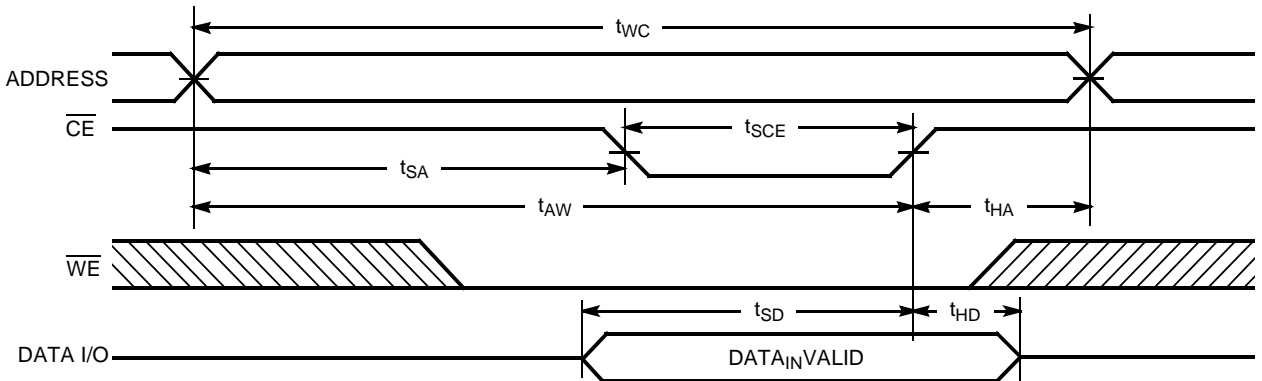
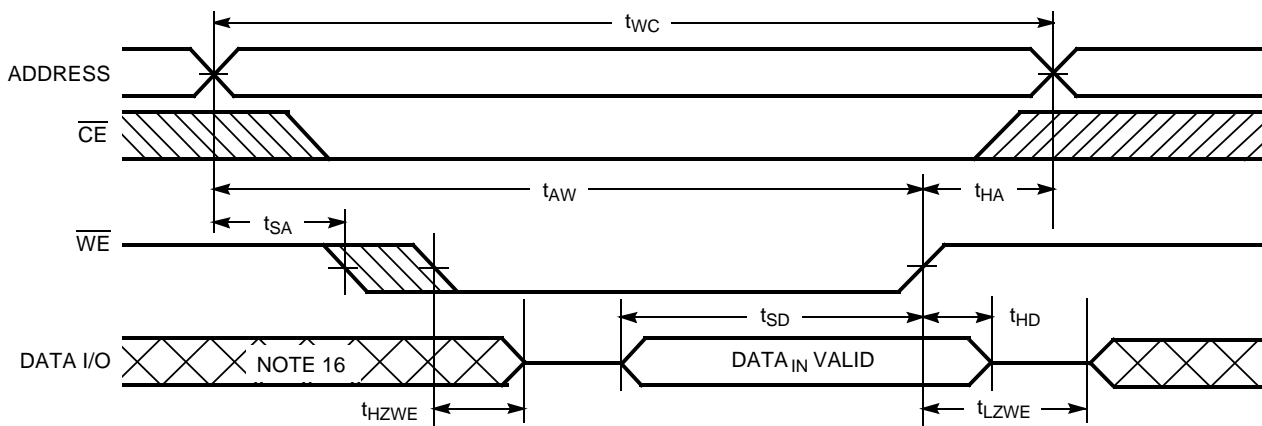
**Read Cycle No. 2<sup>[12, 13]</sup>**

**Notes:**

11. Device is continuously selected.  $\overline{OE}, \overline{CE} = V_{IL}$ .
12. WE is HIGH for read cycle.
13. Address valid prior to or coincident with  $\overline{CE}$  transition LOW.

**Switching Waveforms (continued)**
**Write Cycle No. 1 ( $\overline{WE}$  Controlled)<sup>[9, 14, 15]</sup>**

**Write Cycle No. 2 ( $\overline{CE}$  Controlled)<sup>[9, 14, 15]</sup>**

**Write Cycle No. 3 ( $\overline{WE}$  Controlled,  $\overline{OE}$  LOW)<sup>[10, 15]</sup>**

**Notes:**

14. Data I/O is high impedance if  $\overline{OE} = V_{IH}$ .
15. If  $\overline{CE}$  goes HIGH simultaneously with  $\overline{WE}$  HIGH, the output remains in a high-impedance state.
16. During this period, the I/Os are in the output state and input signals should not be applied.

**Truth Table**

<b>CE</b>	<b>WE</b>	<b>OE</b>	<b>Input/Output</b>	<b>Mode</b>	<b>Power</b>
H	X	X	High Z	Deselect/Power-Down	Standby ( $I_{SB}$ )
L	H	L	Data Out	Read	Active ( $I_{CC}$ )
L	L	X	Data In	Write	Active ( $I_{CC}$ )
L	H	H	High Z	Deselect, Output Disabled	Active ( $I_{CC}$ )

Product and company names mentioned in this document may be the trademarks of their respective holders.
**Ordering Information**

<b>Speed (ns)</b>	<b>Ordering Code</b>	<b>Package Name</b>	<b>Package Type</b>	<b>Operating Range</b>	
10	CY7C1399B-10VC	V21	28-Lead Molded SOJ	Commercial	
	CY7C1399B-10ZC	Z28	28-Lead Thin Small Outline Package		
	CY7C1399BL-10VC	V21	28-Lead Molded SOJ		
	CY7C1399BL-10ZC	Z28	28-Lead Thin Small Outline Package		
12	CY7C1399B-12VC	V21	28-Lead Molded SOJ	Commercial	
	CY7C1399B-12ZC	Z28	28-Lead Thin Small Outline Package		
	CY7C1399BL-12VC	V21	28-Lead Molded SOJ		
	CY7C1399BL-12ZC	Z28	28-Lead Thin Small Outline Package		
	CY7C1399B-12VI	V21	28-Lead Molded SOJ		Industrial
	CY7C1399B-12ZI	Z28	28-Lead Thin Small Outline Package		
15	CY7C1399B-15VC	V21	28-Lead Molded SOJ	Commercial	
	CY7C1399B-15ZC	Z28	28-Lead Thin Small Outline Package		
	CY7C1399BL-15VC	V21	28-Lead Molded SOJ		
	CY7C1399BL-15ZC	Z28	28-Lead Thin Small Outline Package		
	CY7C1399B-15VI	V21	28-Lead Molded SOJ		Industrial
	CY7C1399B-15ZI	Z28	28-Lead Thin Small Outline Package		
20	CY7C1399B-20VC	V21	28-Lead Molded SOJ	Commercial	
	CY7C1399B-20ZC	Z28	28-Lead Thin Small Outline Package		
	CY7C1399BL-20VC	V21	28-Lead Molded SOJ		
	CY7C1399BL-20ZC	Z28	28-Lead Thin Small Outline Package		
	CY7C1399B-20VI	V21	28-Lead Molded SOJ		Industrial
	CY7C1399B-20ZI	Z28	28-Lead Thin Small Outline Package		

Package Diagrams

28-Lead (300-Mil) Molded SOJ V21

DIMENSIONS IN INCHES  
MIN.  
MAX.

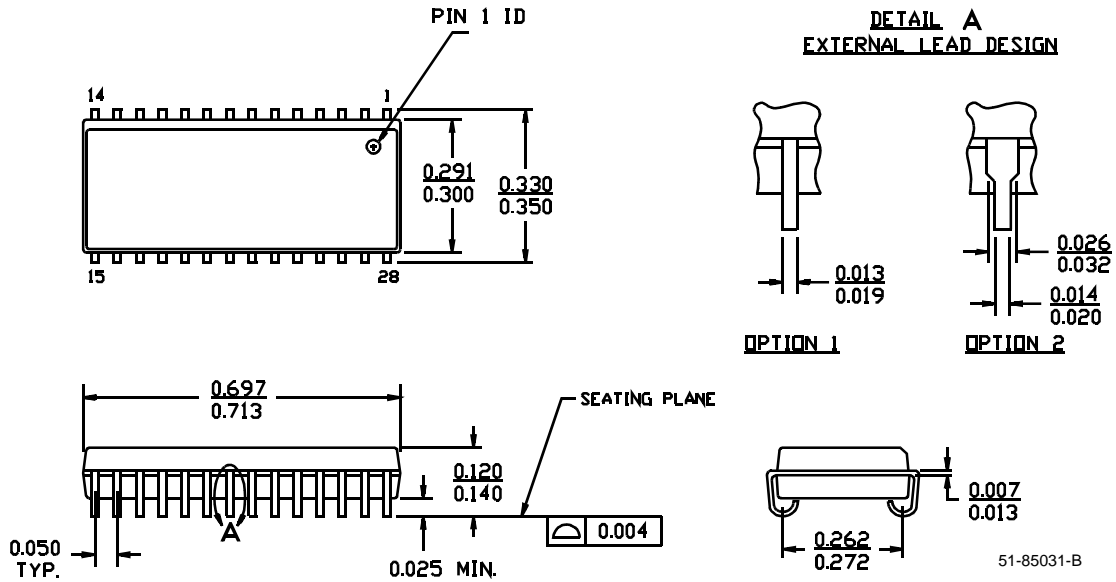

28-Lead Thin Small Outline Package Type 1 (8x13.4 mm) Z28

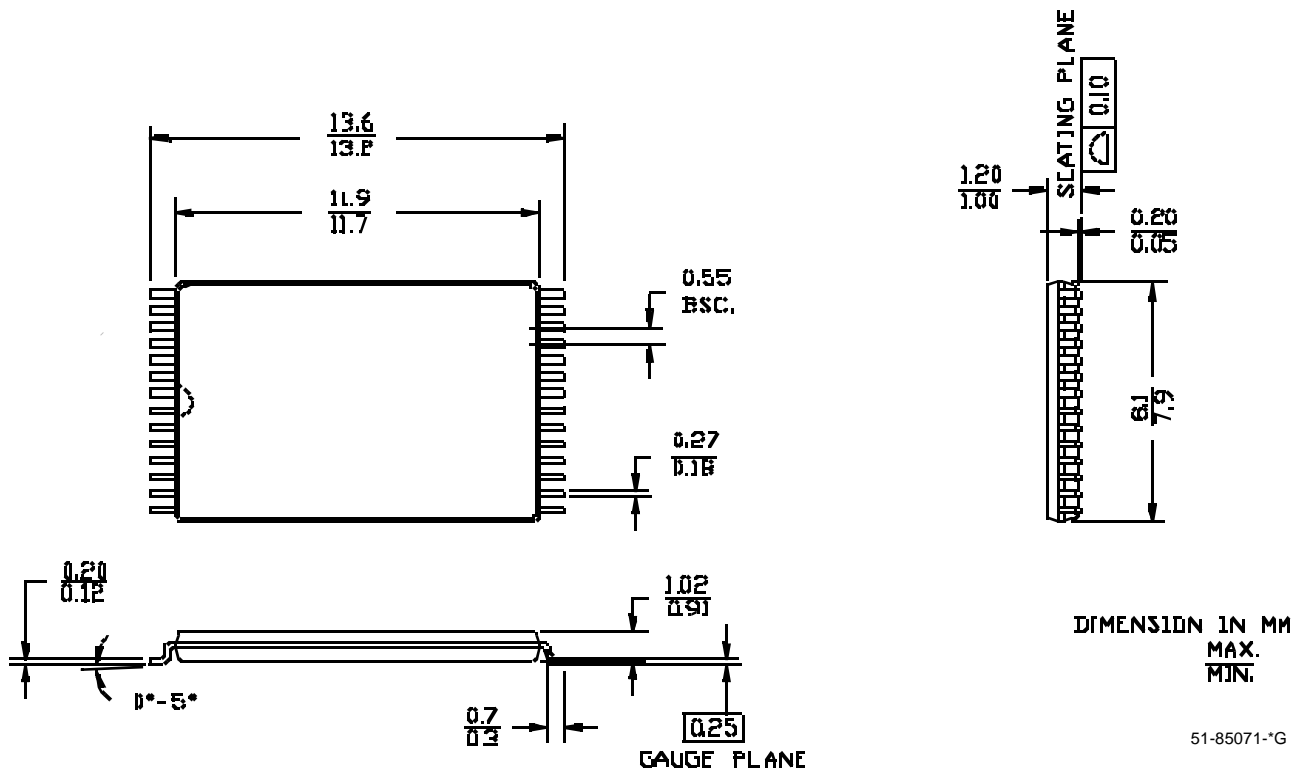

**Document History Page**

<b>Document Title: CY7C1399B 32K x 8 3.3V Static RAM</b>				
<b>Document Number: 38-05071</b>				
<b>REV.</b>	<b>ECN NO.</b>	<b>ISSUE DATE</b>	<b>ORIG. OF CHANGE</b>	<b>DESCRIPTION OF CHANGE</b>
**	107264	05/25/01	SZV	Change from Spec #: 38-01102 to 38-05071
*A	107533	06/28/01	MAX	Add Low Power
*B	116472	09/17/02	CEA	Add applications foot note to data sheet, page 1.
*C	224340	See ECN	RKF	Option 1 of the Orientation ID on TSOP-I Package Diagram [Page #9] removed



LittleDiode supplies new, hard to find or obsolete electronic components and semiconductors all over the world.

With over two million different components listed you are sure to find the part you need.

Feel free to visit us today at our online store:

[LittleDiode.com](http://LittleDiode.com)

Looking forward to providing you with the best possible service.