



64K x 4 Static RAM with Separate I/O

Features

- High speed
 - 12 ns
- CMOS for optimum speed/power
- Low active power
 - 880 mW
- Low standby power
 - 220 mW
- TTL-compatible inputs and outputs
- Automatic power-down when deselected

Functional Description

The CY7C192 is a high-performance CMOS static RAM organized as 65,536 x 4 bits with separate I/O. Easy memory ex-

pansion is provided by active LOW Chip Enable (\overline{CE}) and three-state drivers. It has an automatic power-down feature, reducing the power consumption by 75% when deselected.

Writing to the device is accomplished when the Chip Enable (\overline{CE}) and write enable (\overline{WE}) inputs are both LOW.

Data on the four input pins (I_0 through I_3) is written into the memory location specified on the address pins (A_0 through A_{15}).

Reading the device is accomplished by taking the Chip Enable (\overline{CE}) LOW while the Write Enable (\overline{WE}) remains HIGH. Under these conditions the contents of the memory location specified on the address pins will appear on the four data output pins.

The output pins stay in high-impedance state when Write Enable (\overline{WE}) is LOW, or Chip Enable (\overline{CE}) is HIGH.

A die coat is used to insure alpha immunity.

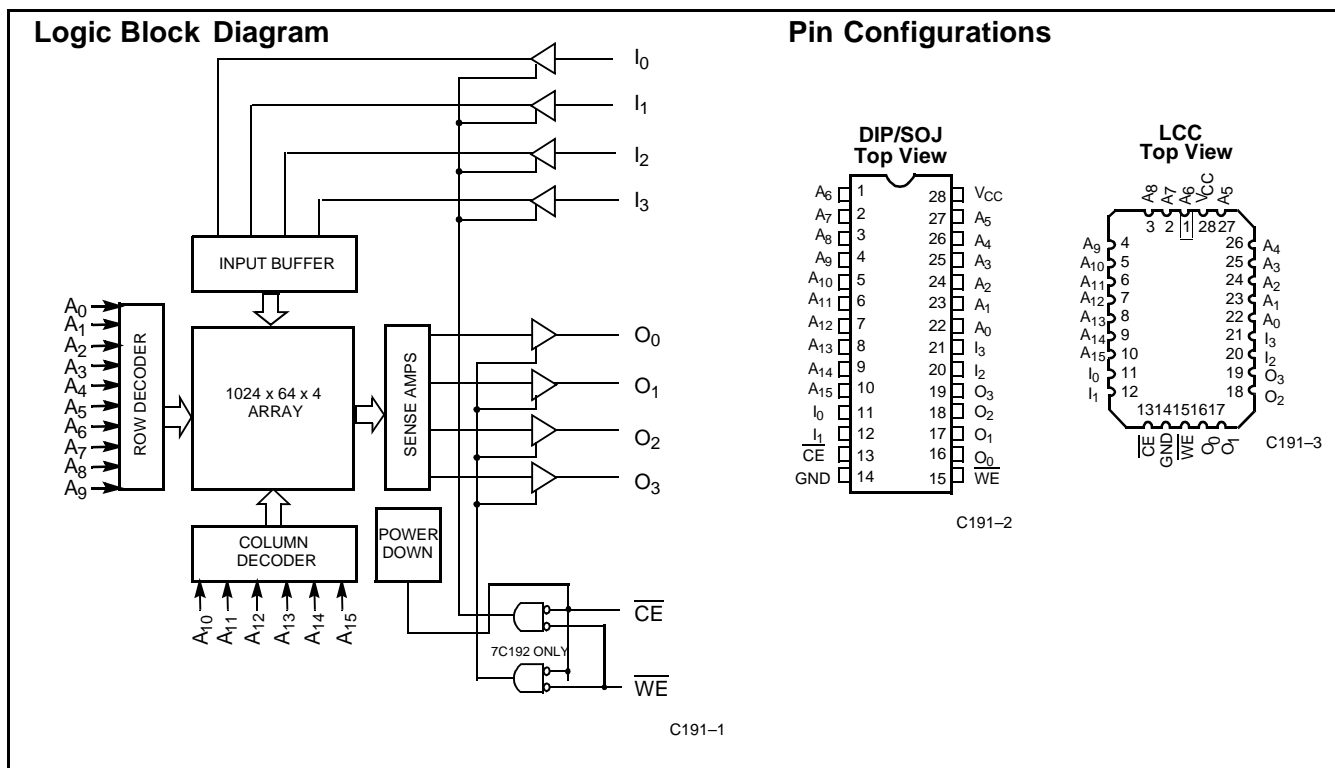

Selection Guide

	7C192-12	7C192-15	7C192-20	7C192-25
Maximum Access Time (ns)	12	15	20	25
Maximum Operating Current (mA)	155	145	135	115
Maximum Standby Current (mA)	30	30	30	30

Maximum Ratings

(Above which the useful life may be impaired. For user guidelines, not tested.)

Storage Temperature -65°C to +150°C
 Ambient Temperature with Power Applied..... -55°C to +125°C
 Supply Voltage to Ground Potential (Pin 28 to Pin 14)..... -0.5V to +7.0V
 DC Voltage Applied to Outputs in High Z State^[1] -0.5V to $V_{CC} + 0.5V$

DC Input Voltage^[1]..... -0.5V to $V_{CC} + 0.5V$
 Output Current into Outputs (LOW)..... 20 mA
 Static Discharge Voltage >2001V (per MIL-STD-883, Method 3015)
 Latch-Up Current..... >200 mA

Operating Range

Range	Ambient Temperature ^[2]	V_{CC}
Commercial	0°C to +70°C	5V ± 10%

Electrical Characteristics Over the Operating Range

Parameter	Description	Test Conditions	7C192-12		7C192-15		Unit
			Min.	Max.	Min.	Max.	
V_{OH}	Output HIGH Voltage	$V_{CC} = \text{Min.}, I_{OH} = -4.0 \text{ mA}$	2.4		2.4		V
V_{OL}	Output LOW Voltage	$V_{CC} = \text{Min.}, I_{OL} = 8.0 \text{ mA}$		0.4		0.4	V
V_{IH}	Input HIGH Voltage		2.2	$V_{CC} + 0.3V$	2.2	$V_{CC} + 0.3V$	V
V_{IL}	Input LOW Voltage ^[1]		-0.5	0.8	-0.5	0.8	V
I_{IX}	Input Load Current	$GND \leq V_I \leq V_{CC}$	-5	+5	-5	+5	µA
I_{OZ}	Output Leakage Current	$GND \leq V_O \leq V_{CC}$, Output Disabled	-5	+5	-5	+5	µA
I_{OS}	Output Short Circuit Current ^[3]	$V_{CC} = \text{Max.}, V_{OUT} = GND$		-300		-300	mA
I_{CC}	V_{CC} Operating Supply Current	$V_{CC} = \text{Max.}, I_{OUT} = 0 \text{ mA}, f = f_{MAX} = 1/t_{RC}$		155		145	mA
I_{SB1}	Automatic \overline{CE} Power-Down Current—TTL Inputs	Max. V_{CC} , $\overline{CE} \geq V_{IH}$, $V_{IN} \geq V_{IH}$ or $V_{IN} \leq V_{IL}$, $f = f_{MAX}$		30		30	mA
I_{SB2}	Automatic \overline{CE} Power-Down Current—CMOS Inputs	Max. V_{CC} , $\overline{CE} \geq V_{CC} - 0.3V$, $V_{IN} \geq V_{CC} - 0.3V$ or $V_{IN} \leq 0.3V$, $f = 0$		10		10	mA

Notes:

1. Minimum voltage is equal to -2.0V for pulse durations of less than 20 ns.
2. T_A is the case temperature.
3. Not more than 1 output should be shorted at one time. Duration of the short circuit should not exceed 30 seconds.

Electrical Characteristics Over the Operating Range

Parameter	Description	Test Conditions	7C192-20		7C192-25		Unit
			Min.	Max.	Min.	Max.	
V _{OH}	Output HIGH Voltage	V _{CC} = Min., I _{OH} = -4.0 mA	2.4		2.4		V
V _{OL}	Output LOW Voltage	V _{CC} = Min., I _{OL} = 8.0 mA		0.4		0.4	V
V _{IH}	Input HIGH Voltage		2.2	V _{CC} + 0.3V	2.2	V _{CC} + 0.3V	V
V _{IL}	Input LOW Voltage ^[1]		-0.5	0.8	-3.0	0.8	V
I _{IX}	Input Load Current	GND ≤ V _I ≤ V _{CC}	-5	+5	-5	+5	μA
I _{OZ}	Output Leakage Current	GND ≤ V _O ≤ V _{CC} , Output Disabled	-5	+5	-5	+5	μA
I _{OS}	Output Short Circuit Current ^[3]	V _{CC} = Max., V _{OUT} = GND		-300		-300	mA
I _{CC}	V _{CC} Operating Supply Current	V _{CC} = Max., I _{OUT} = 0 mA, f = f _{MAX} = 1/t _{RC}		135		115	mA
I _{SB1}	Automatic \overline{CE} Power-Down Current—TTL Inputs	Max. V _{CC} , $\overline{CE} \geq V_{IH}$, V _{IN} ≥ V _{IH} or V _{IN} ≤ V _{IL} , f = f _{MAX}		30		30	mA
I _{SB2}	Automatic \overline{CE} Power-Down Current—CMOS Inputs	$\overline{CE} \geq V_{CC} - 0.3V$, V _{IN} ≤ V _{CC} - 0.3V or V _{IN} ≤ 0.3V, f = 0		15		15	mA

Capacitance^[4]

Parameter	Description	Test Conditions	Max.	Unit
C _{IN}	Input Capacitance	T _A = 25°C, f = 1 MHz, V _{CC} = 5.0V	8	pF
C _{OUT}	Output Capacitance		10	pF

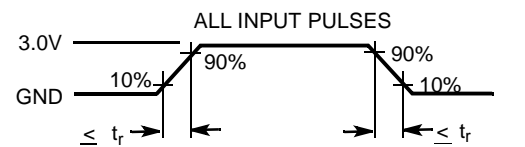
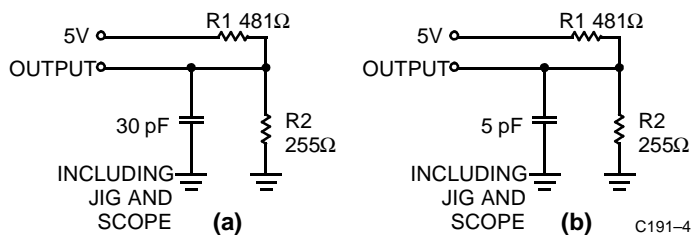
AC Test Loads and Waveforms^[5]

C191-5

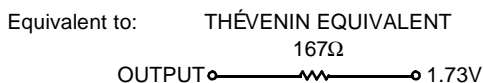
Notes:

- Tested initially and after any design or process changes that may affect these parameters.
- t_r = ≤ 3 ns for the -12 and -15 speeds. T_r = ≤ 5 ns for the -20 and slower speeds.

Switching Characteristics Over the Operating Range^[6]

Parameter	Description	7C192-12		7C192-15		7C192-20		7C192-25		Unit
		Min.	Max.	Min.	Max.	Min.	Max.	Min.	Max.	
READ CYCLE										
t _{RC}	Read Cycle Time	12		15		20		25		ns
t _{AA}	Address to Data Valid		12		15		20		25	ns
t _{OHA}	Output Hold from Address Change	3		3		3		3		ns
t _{ACE}	$\overline{\text{CE}}$ LOW to Data Valid		12		15		20		25	ns
t _{LZCE}	$\overline{\text{CE}}$ LOW to Low Z ^[7]	3		3		3		3		ns
t _{HZCE}	$\overline{\text{CE}}$ HIGH to High Z ^[7,8]		5		7		9		11	ns
t _{PU}	$\overline{\text{CE}}$ LOW to Power-Up	0		0		0		0		ns
t _{PD}	$\overline{\text{CE}}$ HIGH to Power-Down		12		15		20		25	ns
WRITE CYCLE^[9]										
t _{WC}	Write Cycle Time	12		15		20		25		ns
t _{SCE}	$\overline{\text{CE}}$ LOW to Write End	9		10		15		18		ns
t _{AW}	Address Set-Up to Write End	9		10		15		20		ns
t _{HA}	Address Hold from Write End	0		0		0		0		ns
t _{SA}	Address Set-Up to Write Start	0		0		0		0		ns
t _{PWE}	$\overline{\text{WE}}$ Pulse Width	8		9		15		18		ns
t _{SD}	Data Set-Up to Write End	8		9		10		10		ns
t _{HD}	Data Hold from Write End	0		0		0		0		ns
t _{LZWE}	$\overline{\text{WE}}$ HIGH to Low Z (7C192) ^[7]	3		3		3		3		ns
t _{HZWE}	$\overline{\text{WE}}$ LOW to High Z (7C192) ^[7,8]		7		7		10		11	ns
t _{DWE}	$\overline{\text{WE}}$ LOW to Data Valid (7C191)		12		15		20		25	ns
t _{ADV}	Data Valid to Output Valid (7C191)		12		15		20		20	ns
t _{DCE}	$\overline{\text{CE}}$ LOW to Data Valid (7C191)		12		15		20		25	ns

Notes:

- Test conditions assume signal transition time of 3 ns or less for -12 and -15 speeds and 5 ns or less for -20 through -25 speeds, timing reference levels of 1.5V, input pulse levels of 0 to 3.0V, and output loading of the specified I_{OL}/I_{OH} and 30-pF load capacitance.
- At any given temperature and voltage condition, t_{HZCE} is less than t_{LZCE}, t_{HZWE} is less than t_{LZWE} for any given device. These parameters are guaranteed by design and not 100% tested.
- t_{HZCE} and t_{HZWE} are specified with C_L = 5 pF as in part (b) of AC Test Loads. Transition is measured ±500 mV from steady-state voltage.
- The internal write time of the memory is defined by the overlap of $\overline{\text{CE}}$ LOW and $\overline{\text{WE}}$ LOW. Both signals must be LOW to initiate a write and either signal can terminate a write by going HIGH. The data input set-up and hold timing should be referenced to the rising edge of the signal that terminates the write.

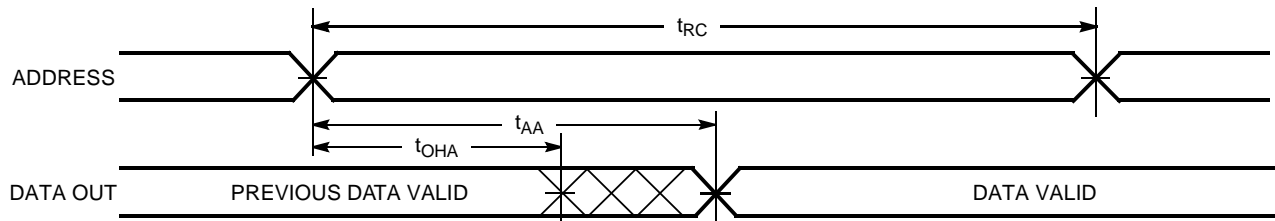
Switching Waveforms
Read Cycle No. 1^[10, 11]

C191-6

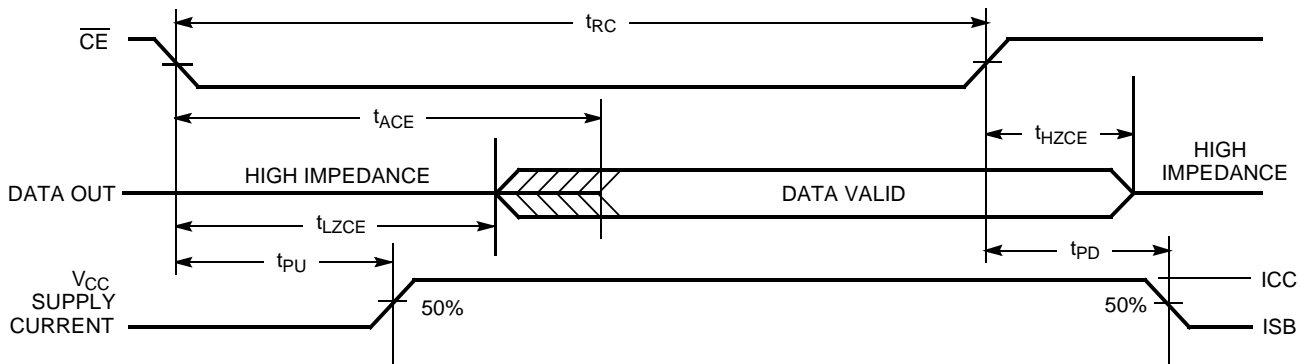
Read Cycle No. 2^[10, 12]

C191-7

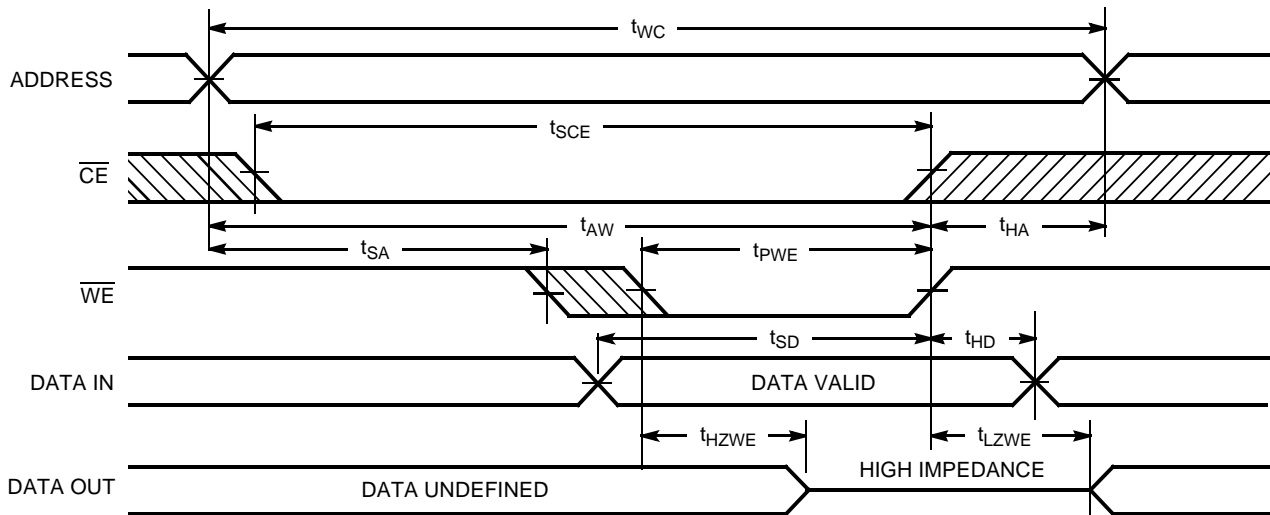
Write Cycle No. 1 (WE Controlled)^[9]

C191-8

Notes:

10. WE is HIGH for read cycle.
11. Device is continuously selected, $\overline{CE} = V_{LL}$.
12. Address valid prior to or coincident with \overline{CE} transition LOW.

Switching Waveforms (continued)

Write Cycle No. 2 (\overline{CE} Controlled)^[9, 13]

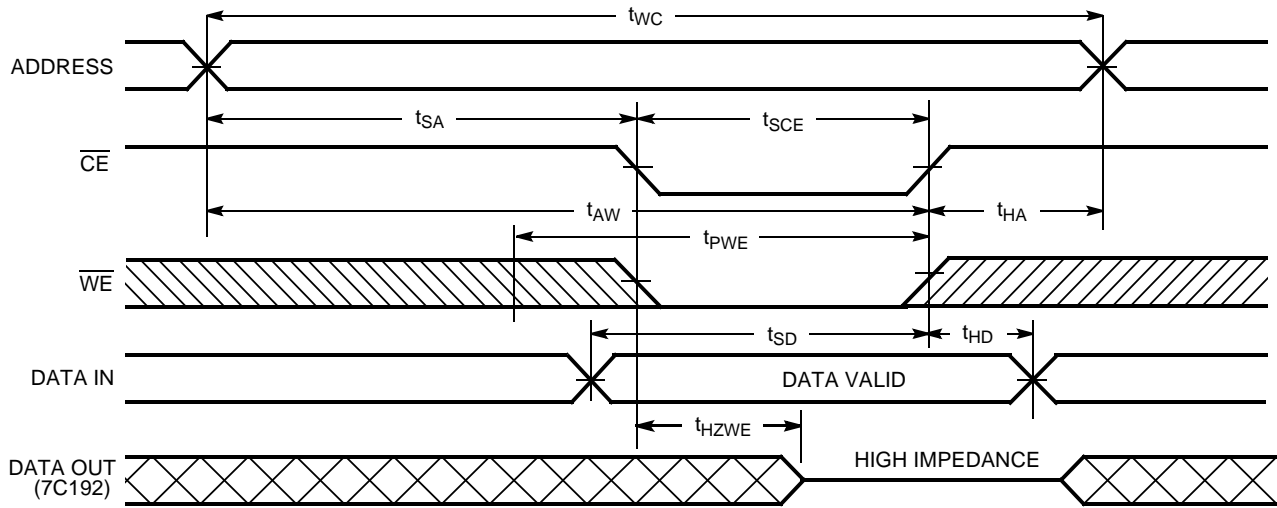

C191-9

Notes:

- 13. If \overline{CE} goes HIGH simultaneously with \overline{WE} HIGH, the output remains in a high-impedance state.

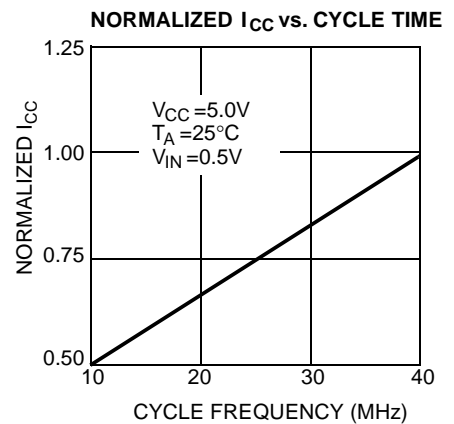
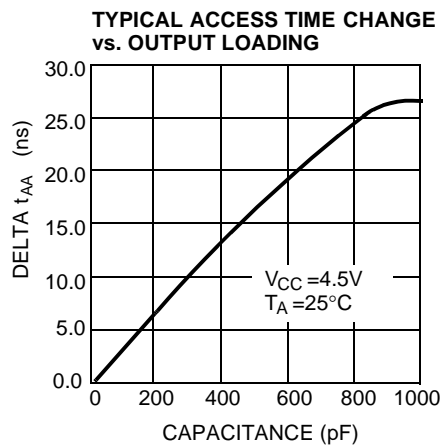
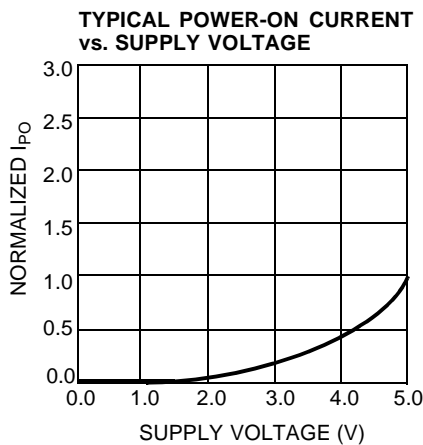
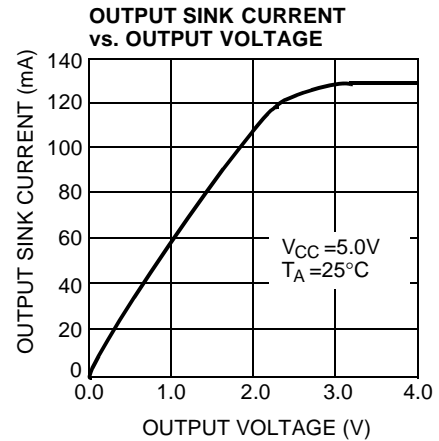
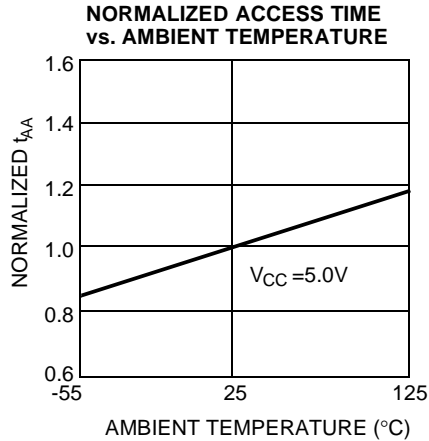
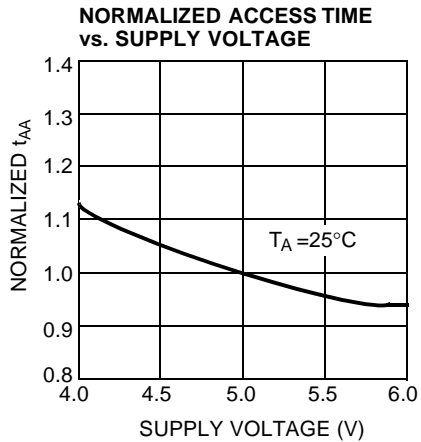
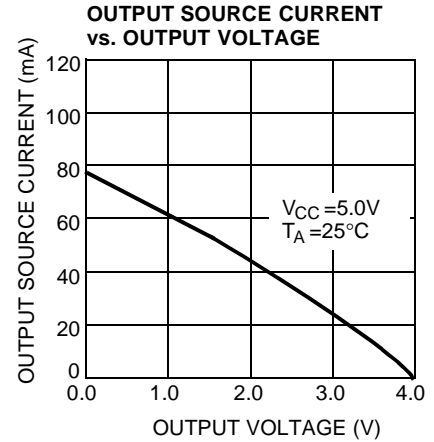
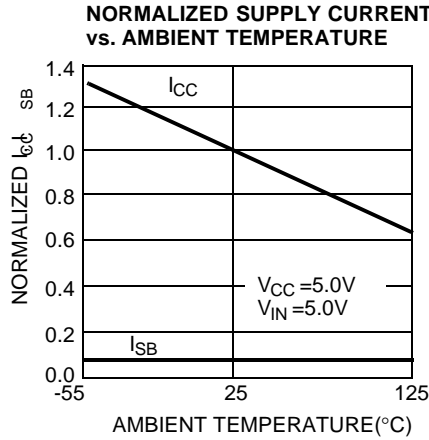
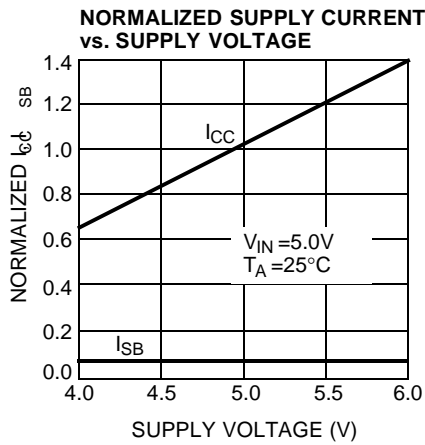
Typical DC and AC Characteristics

Ordering Information

Speed (ns)	Ordering Code	Package Name	Package Type	Operating Range
12	CY7C192-12PC	P21	28-Lead (300-Mil) Molded DIP	Commercial
	CY7C192-12VC	V21	28-Lead Molded SOJ	
15	CY7C192-15PC	P21	28-Lead (300-Mil) Molded DIP	Commercial
	CY7C192-15VC	V21	28-Lead Molded SOJ	
20	CY7C192-20PC	P21	28-Lead (300-Mil) Molded DIP	Commercial
	CY7C192-20VC	V21	28-Lead Molded SOJ	
25	CY7C192-25PC	P21	28-Lead (300-Mil) Molded DIP	Commercial
	CY7C192-25VC	V21	28-Lead Molded SOJ	

Package Diagrams

28-Lead (300-Mil) Molded DIP P21

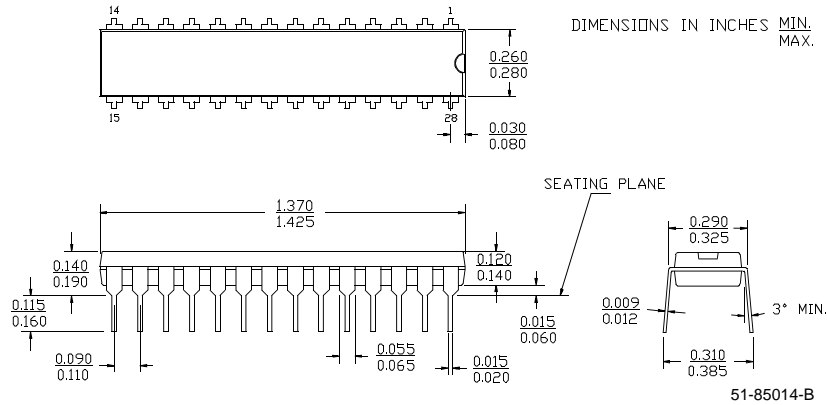

28-Lead (300-Mil) Molded SOJ V21

DIMENSIONS IN INCHES MIN. MAX.

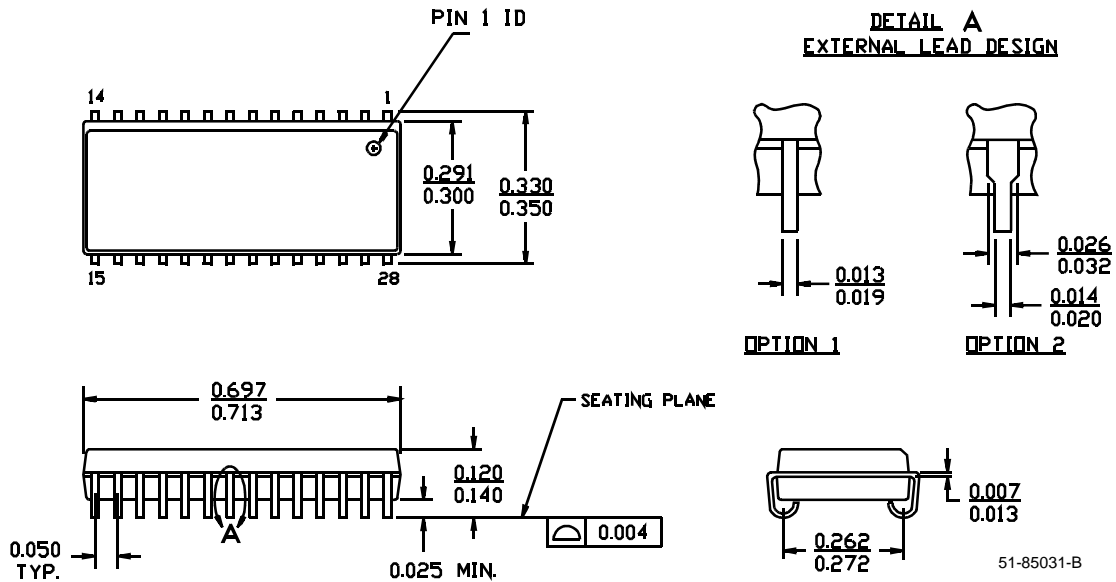

Document Title: CY7C192 64K x 4 Static RAM with Separate I/O
Document Number: 38-05047

REV.	ECN NO.	Issue Date	Orig. of Change	Description of Change
**	107149	09/10/01	SZV	Change Spec number from: 38-00076 to 38-05047



LittleDiode supplies new, hard to find or obsolete electronic components and semiconductors all over the world.

With over two million different components listed you are sure to find the part you need.

Feel free to visit us today at our online store:

LittleDiode.com

Looking forward to providing you with the best possible service.